

Sand crab digging: the neuroethology and evolution of a "new" behaviour

by

Zen Faulkes
Bachelor of Arts and Science (B.Sc.)
University of Lethbridge, 1989

A dissertation submitted in partial fulfilment of the requirements for the degree of

DOCTOR OF PHILOSOPHY

in the Department of Biology

We accept this dissertation as conforming to the required standard:

Dorothy H. Paul, Supervisor (Department of Biology)

George O. Mackie, Departmental Member (Department of Biology)

Craig Hawryshyn, Departmental Member (Department of Biology)

Geraldine van Gyn, Outside Member (Department of Physical Education)

Joseph L. Ayers, External Examiner (Marine Science Center, Northeastern University)

Copyright © 1996 Zen Faulkes
University of Victoria

All rights reserved. This dissertation may not be reproduced in whole or in part, by photocopying or other means, without the permission of the author.

Supervisor: Dorothy H. Paul

ABSTRACT

Sand crabs (Anomura: Hippoidea) have evolved a “new” means of locomotion: they use their thoracic legs to dig into the sand instead of walking on the benthos as many other decapod crustaceans do. I examined digging by three sand crab species of two families, *Blepharipoda occidentalis* (Albuneidae), *Lepidopa californica* (Albuneidae) and *Emerita analoga* (Hippidae). There are several features common to both sand crab families, suggesting that digging has evolved only once in the sand crabs. The leg tip trajectories are similar, with leg 4 circling in the opposite direction to legs 2 and 3 when viewed from the side; contralateral legs tend to alternate; the “tail” (abdomen in albuneids; uropods in hippids) cycles at higher frequencies than the legs; and the interjoint coordination of a single given leg (e.g., leg 2) is similar in *B. occidentalis* and *E. analoga*. There are also features that distinguish the two families. During digging by the albuneids, serially homologous contralateral legs initially alternate, but switch midway through a digging episode to moving synchronously. In *E. analoga*, the legs 2 and 3 move in bilateral alternation throughout the dig, but the legs 4 can move in bilateral synchrony and a higher frequency than legs 2 and 3 (\approx the uropods’ frequency). There are also some similarities between sand crab digging and walking by other decapods, suggesting the two behaviours may be homologous. The coordination of ipsilateral legs on one side of an animal is generally similar in digging and closely related walking species, and there are no obvious differences in the distal leg motor neurons in sand crabs and some walking species. Digging and walking differ in that there are rapid “tail” movements during digging but not

walking, and that serially homologous digging legs are more specialised in their motor output than walking legs. The interjoint coordination of legs 2 and 3 resemble backward walking motor patterns by other decapods, whereas that of leg 4 is more similar to forward walking. This suggests that digging is an evolutionary mosaic, comprised of several modified ancestral locomotor behaviours (backward walking in legs 2 and 3, forward walking in leg 4, and tailflipping).

Examiners:

Dorothy H. Paul, Supervisor (Department of Biology)

George O. Mackie, Departmental Member (Department of Biology)

Craig Hawryshyn, Departmental Member (Department of Biology)

Geraldine van Gyn, Outside Member (~~Department~~ of Physical Education)

Joseph L. Ayers, External Examiner (Marine Science Center, Northeastern University)

TABLE OF CONTENTS

ABSTRACT	ii
TABLE OF CONTENTS	iv
LIST OF TABLES	viii
LIST OF FIGURES	ix
LIST OF ABBREVIATIONS	xii
ACKNOWLEDGEMENTS	xiv
DEDICATION	xv
Chapter 1: Exposition	1
<i>The Animals</i>	1
Sand crab natural history	7
Survival value of digging	7
Ontogeny of digging	8
Sand crab fossil record	8
<i>The Problem</i>	9
Homology: definitions and difficulties	9
Homologies and behaviour	11
<i>The Techniques</i>	12
Eshkol-Wachman movement notation (EW)	12
Electromyograms (EMGs)	14
<i>Overview</i>	15
Chapter 2: Interleg coordination	17
<i>Introduction</i>	17
<i>Methods</i>	18
Data treatment	20
<i>Results</i>	21
Tip trajectories	21
Speed	33
Ipsilateral coordination	36
<i>Munida quadrispina</i>	36
<i>Blepharipoda occidentalis</i>	36
<i>Lepidopa californica</i>	37
<i>Emerita analoga</i>	37

Bilateral coordination.....	47
<i>Blepharipoda occidentalis</i> and <i>Lepidopa californica</i>	47
Perturbations in bilateral coordination caused by leg loss.....	54
<i>Emerita analoga</i>	58
<i>Discussion</i>	67
Homology and divergence in sand crab digging.....	67
Evolutionary origins for digging	68
Central control	69
Sensory input.....	70
Chapter 3: Interjoint coordination	72
<i>Introduction</i>	72
<i>Methods</i>	74
Omissions and limitations	74
<i>Results</i>	78
Sand crab leg morphology	78
Movement analysis of interjoint coordination in <i>B. occidentalis</i>	83
Legs 2 and 3.....	83
Leg 4	83
Anecdotal observations of leg 1	84
Correlating movements and motor patterns above and below sand	96
Comparing coordination of <i>B. occidentalis</i> and <i>E. analoga</i>	96
Coordination of proximal joints.....	112
EMG burst and period.....	130
Opener and stretcher EMGs	148
<i>Discussion</i>	156
Predictions about the digging pattern generators.....	156
Sensory input	156
Central connections.....	157
Is sand crab digging an evolutionary mosaic?.....	159
Chapter 4: Coordination of the legs and “tail”	162
<i>Introduction</i>	162
<i>Results</i>	163
<i>Blepharipoda occidentalis</i> and <i>Lepidopa californica</i>	163
<i>Emerita analoga</i>	173
Antennal anecdotes	180

<i>Discussion</i>	180
Digging = Walking (modified) + tailflipping?.....	181
Chapter 5: Attempts to elicit fictive digging.....	183
<i>Introduction</i>	183
<i>Methods</i>	184
<i>Results</i>	184
<i>Discussion</i>	184
Chapter 6: Distal leg motor neurons.....	187
<i>Introduction</i>	187
<i>Methods</i>	193
<i>Results</i>	195
The reductor muscle is triply innervated.....	195
Somata locations and axons' exit routes.....	196
<i>Munida quadrispina</i>	203
<i>Blepharipoda occidentalis</i>	206
<i>Lepidopa californica</i>	206
<i>Emerita analoga</i>	207
<i>Pacifastacus leniusculus</i>	207
Cell morphology.....	208
Non-motor neurons.....	214
<i>Discussion</i>	217
Legs and swimmerets.....	224
Non-motor cells.....	225
Do palinurans have different leg motor neurons?.....	225
Chapter 7: Synthesis.....	229
<i>Hypotheses of homology</i>	229
Homology and divergence within the sand crabs.....	229
Homology of digging and waiking.....	229
<i>What next?</i>	236
REFERENCES.....	229
Appendix A: Eshkol-Wachman movement notation.....	259
Appendix B: An annotated bibliography of Eshkol-Wachman movement notation.....	263

Appendix C: Video synchronisation 269

LIST OF TABLES

Table 1.1: Sand crab taxonomy	5
Table 3.1: Ranges of joint movement in some walking species and <i>B. occidentalis</i>	81
Table 3.2: Mean phases of leg 2 proximal muscles and leg 4 proximal muscles in <i>B. occidentalis</i> and <i>E. analoga</i>	116
Table 3.3: Regression values of EMG burst durations and period in <i>B. occidentalis</i>	133
Table 3.4: Regression values of EMG burst durations and period in <i>E. analoga</i>	141
Table 6.1: Review of distal leg motor neuron number and exit route	190
Table 6.2: Leg motor neuron exit routes	204
Table 6.3: Summary of leg motor neuron location and and exit routes	220
Table 7.1: Sample matrix of locomotor characteristics	235

LIST OF FIGURES

Figure 1.1: Phylogenies.....	2
Figure 2.1: <i>B. occidentalis</i> leg tip trajectories	23
Figure 2.2: <i>L. californica</i> leg tip trajectories	25
Figure 2.3: <i>E. analoga</i> leg tip trajectories	27
Figure 2.4: Leg tip velocity during forward and backward movements in <i>B. occidentalis</i>	29
Figure 2.5: Leg tip velocity during forward and backward movements in <i>E. analoga</i>	31
Figure 2.6: Speed of <i>B. occidentalis</i> , <i>L. californica</i> , and <i>E. analoga</i>	34
Figure 2.7: Power and return strokes	39
Figure 2.8: Coupling of legs 2 and 3 in <i>B. occidentalis</i> , <i>L. californica</i> , and <i>E. analoga</i> ..	41
Figure 2.9: Coupling of legs 2 and 3 during digging by <i>B. occidentalis</i>	43
Figure 2.10: Coupling of legs 2 and 4 in <i>E. analoga</i>	45
Figure 2.11: Histograms of bilateral coordination in <i>B. occidentalis</i> , <i>L. californica</i> and <i>E. analoga</i>	48
Figure 2.12: Gait switch in <i>B. occidentalis</i>	50
Figure 2.13: Gait switch in <i>L. californica</i>	52
Figure 2.14: Perturbations in gait switch in <i>B. occidentalis</i>	55
Figure 2.15: Bilateral coordination of legs 2 and 3 in <i>E. analoga</i>	59
Figure 2.16: Bilateral coordination of legs 4 in <i>E. analoga</i>	61
Figure 2.17: Coupling of bilateral legs 4 in <i>E. analoga</i>	63
Figure 2.18: Circular plots of bilateral coordination in <i>B. occidentalis</i> , <i>L. californica</i> , and <i>E. analoga</i>	65
Figure 3.1: Temporal relationships	76
Figure 3.2: Leg morphologies	79
Figure 3.3: Sample EW/EMG score in <i>B. occidentalis</i>	86
Figure 3.4: Interjoint coordination of <i>B. occidentalis</i>	88
Figure 3.5: Power stroke synergists	90
Figure 3.6: Return stroke synergists.....	92
Figure 3.7: FLX and DEP coordination in <i>B. occidentalis</i>	94

Figure 3.8: RED and BND in <i>B. occidentalis</i> and <i>E. analoga</i>	98
Figure 3.9: EXT and CL in <i>B. occidentalis</i> and <i>E. analoga</i>	100
Figure 3.10: EXT and BND in <i>B. occidentalis</i> and <i>E. analoga</i>	102
Figure 3.11: EXT and FLX in <i>B. occidentalis</i>	104
Figure 3.12: EXT and STR in <i>B. occidentalis</i>	106
Figure 3.13: Phase of CL in BND in <i>B. occidentalis</i> and <i>E. analoga</i>	108
Figure 3.14: Phase of BND in EXT in <i>B. occidentalis</i> and <i>E. analoga</i>	110
Figure 3.15: Sequence of proximal joint movements during walking.....	114
Figure 3.16: EMGs of leg 2 proximal muscles in <i>B. occidentalis</i> and <i>E. analoga</i>	118
Figure 3.17: EMGs of leg 4 proximal muscles in <i>B. occidentalis</i> and <i>E. analoga</i>	120
Figure 3.18: Phase histograms of leg 2 proximal muscles in <i>B. occidentalis</i> and <i>E. analoga</i>	122
Figure 3.19: Phase histograms of leg 2 proximal muscles in <i>B. occidentalis</i> and <i>E. analoga</i>	124
Figure 3.20: Phase/period plots of leg 2 proximal muscles in <i>B. occidentalis</i> and <i>E.</i> <i>analoga</i>	126
Figure 3.21: Phase/period plots of leg 4 proximal muscles in <i>B. occidentalis</i> and <i>E.</i> <i>analoga</i>	128
Figure 3.22: Sinusoidal leg 2 movements above sand in <i>B. occidentalis</i>	131
Figure 3.23: Leg 2 burst/period plots for <i>B. occidentalis</i>	135
Figure 3.24: Leg 4 burst/period plots for <i>B. occidentalis</i>	138
Figure 3.25: Leg 2 burst/period plots for <i>E. analoga</i>	143
Figure 3.26: Leg 4 burst/period plots for <i>E. analoga</i>	146
Figure 3.27: OP and STR EMGs in <i>B. occidentalis</i> and <i>E. analoga</i>	151
Figure 3.28: Opener antagonists in <i>B. occidentalis</i>	154
Figure 4.1: Tip trajectories of legs and “tail” in <i>B. occidentalis</i> and <i>E. analoga</i>	165
Figure 4.2: Coordination of leg and abdomen in <i>B. occidentalis</i>	167
Figure 4.3: Coordination of leg and abdomen in <i>L. californica</i>	169
Figure 4.4: Coordination of leg and “tail” in <i>B. occidentalis</i> and <i>L. californica</i>	171

Figure 4.5: EMGs of leg 4 and “tail” in <i>E. analoga</i>	174
Figure 4.6: EMGs of legs 2, 4, and “tail” in <i>E. analoga</i>	176
Figure 4.7: Coupling of leg 4 and “tail” in <i>E. analoga</i>	178
Figure 6.1: Photographs of distal leg motor neurons	199
Figure 6.2: Maps of distal leg motor neurons.	201
Figure 6.3: Position of CI	210
Figure 6.4: Morphology of aFE motor neuron.....	212
Figure 6.5: Putative neurosecretory cells.....	215
Figure 6.6: Typical reptantian leg innervation.....	218
Figure 7.1: Model of neural bases for sand crab digging.....	231

LIST OF ABBREVIATIONS

AB	Abdomen
aFE	Accessory flexor muscle excitor motor neuron
aFLX	Accessory flexor muscle; aids in flexing carpus relative to merus
BE (FBE, SBE)	Bender excitor motor neuron (fast and slow)
BND	Bender muscle; flexes propus relative to carpus
CI	Common inhibitor motor neuron
CL	Closer muscle; flexes dactyl relative to propus
DEP	Depressor muscle; lowers basi-ischium relative to coxa
EE (FEE, SEE)	Flexor excitor motor neuron (fast and slow)
EMG	Electromyogram
EW	Eshkol-Wachman movement notation
EXT	Extensor muscle; extends carpus relative to merus
FE (FE _α , FE _β , FE _γ , FE _ρ)	Flexor excitor motor neuron (alpha, beta, gamma, rho)
FLX	Flexor muscle; flexes carpus relative to merus
T4-8	Thoracic ganglia innervating the legs
LEV	Levator muscle; raises basi-ischium relative to coxa
N1(A+P)V	Unbranched thoracic nerve innervating distal leg
N1AV	Anterior of two thoracic nerves innervating distal leg
N1PV	Posterior of two thoracic nerves innervating distal leg
OE≡SE	Excitatory motor neuron shared between opener and stretcher muscle
OP	Opener muscle; extends dactyl relative to propus
PRO	Promotor muscle; moves coxa forward relative to thorax
RE (FRE, SRE)	Reductor excitor motor neuron (fast and slow)
RED	Reductor muscle; extends merus slightly relative to basi-ischium
REM	Remotor muscle; moves the coxa backwards relative to thorax

SI	Stretcher inhibitor motor neuron
STR	Stretcher muscle; extends propus relative to carpus
UR	Uropods (usually in <i>E. analoga</i>)

ACKNOWLEDGEMENTS

Jake Jacobs provided a lot of the initial inspiration for this work, as he drew my attention to Eshkol-Wachman movement notation and its possible power in the analysis of animal behaviour. Jennifer Mather also shares part of the blame: she got me started in invertebrate locomotion (when I wandered into her office, said that octopus walking sounded interesting, and was unexpectedly swept into the world of cephs), and rereading her paper on squid digging [Mather 1986] after I arrived in Victoria set me to thinking about sand crab digging. Both have been enthusiastic supporters. Sergio Pellis and Vivien Pellis taught me Eshkol-Wachman movement notation and continued to be welcome collaborators throughout this project by lending ideas, expertise, friendship, and their Peak Performance system (not necessarily in that order). Roberto Racca and Pat Kerfoot designed and built, respectively, the video sync device that was vital to my research. Ely Wallis and an anonymous referee for *Brain, Behaviour and Evolution* carefully criticised early versions of Chapter 6. Jenifer Dugan, David Hubard, Kevin Lafferty, Brian Antonsen and Anne Pound (a.k.a. "Team *Lepidopa* '95") helped to collect the elusive *Lepidopa*. I'd also like to thank Ely and Brian for being most excellent labmates, officemates, and colleagues. George Mackie, Craig Hawryshyn, and Geri van Gyn have been everything that a graduate committee should be and so rarely is: constructive, not destructive. Finally, it has been a privilege to be a student of Dorothy Paul. All of these people have taught me a lot about scientific rigour and excellence. For everything, I can only say thanks and hope that this work, and whatever might follow it, lives up to the standard set by their example.

This research was supported by an Animal Behaviour Society research grant and an Natural Science and Engineering Research Council Post-Graduate 2 scholarship.

DEDICATION

This work is dedicated to Alyx Millar.

Chapter 1: Exposition

Seldon said, almost as though muttering to himself, "How harmful overspecialization is. It cuts knowledge at a million points and leaves it bleeding."
[Asimov 1988: 78]

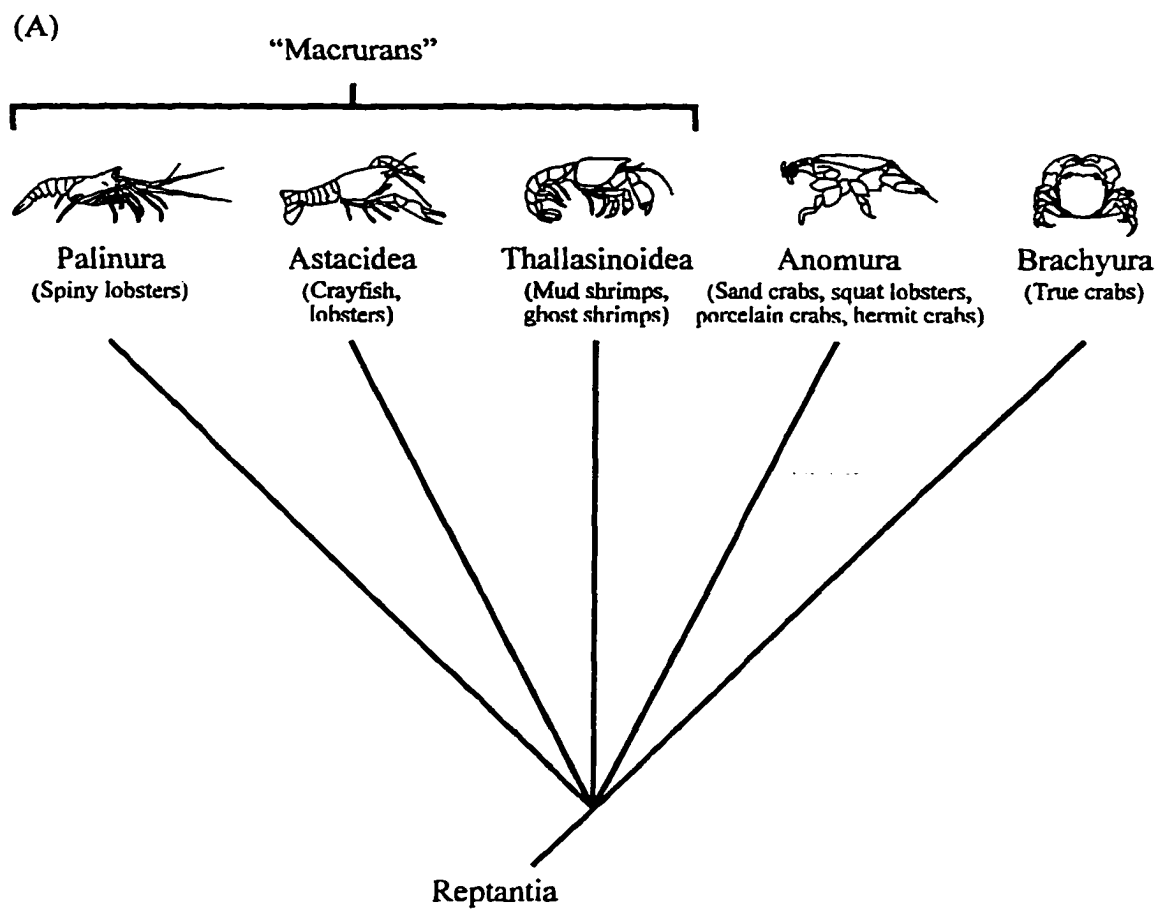
The Animals

Decapoda, the largest and most familiar crustacean order, consists of about 1,200 described genera and 10,000 described species [Bowman & Abele 1982], and most of these species walk using their thoracic legs [Hessler 1982, 1985], particularly the reptantians (Figure 1.1A). Sand crabs (Anomura: Hippoidea) are an exception: they dig rapidly into sand using their thoracic legs and "tail" [Trueman 1970]. These animals are so specialised for digging that they have lost the ability to walk, or even to locomote in any direction other than backwards. In order to understand how sand crabs dig, how their nervous systems might control digging movements, and how digging behaviour evolved, I examined the digging behaviour of three sand crab species: the spiny sand crab, *Blepharipoda occidentalis* (Family Albuneidae), the pearly sand crab, *Lepidopa californica* (Albuneidae), and the mole sand crab, *Emerita analoga* (Hippidae). These three species are members of genera that are not closely related (Figure 1.1B), so they should be reasonable representatives for the hippoid superfamily. Because digging is a locomotor behaviour involving the thoracic legs, I hypothesised that digging may be a highly modified form of walking, and that the two behaviours are homologous.

Figure 1.1: Phylogenies

(A) The five infraorders of the decapod suborder Reptantia [Schram 1986]. The reptantians are generally thought to be a monophyletic group [but see Williamson 1988 regarding *Palinura*], but there is no widely agreed upon phylogeny of the infraorders [Katz & Tazaki 1992; Schram 1986]. The term “macruran” is descriptive (“long tailed”) and not meant to describe a monophyletic group; shrimps and prawns (i.e., non-reptantian decapods) are also considered macrurans. Sand crabs belong to the infraorder Anomura.

(B) Hypothesised phylogeny of sand crab genera [Efford 1969; Serène 1979; Snodgrass 1952]. This phylogeny was not based on a quantitative cladistic analysis.



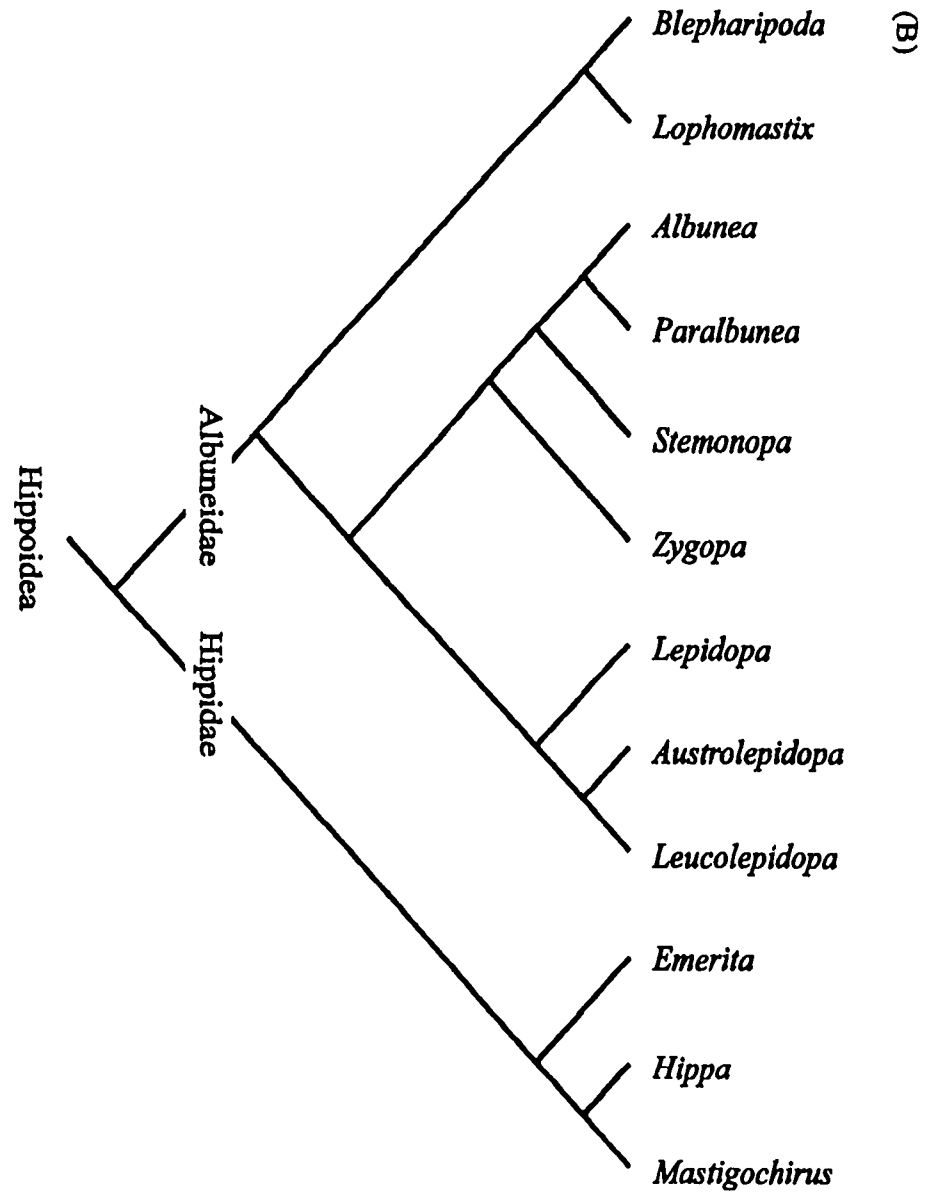


Table 1.1: Sand crab taxonomy

Based on Efford [1969], McLaughlin and Holthuis [1985], Schram [1986], and Snodgrass [1952]. The number of described species in each genus is shown in brackets.

Table 1.1

Phylum ARTHROPODA Von Seibold, 1848	
Subphylum CRUSTACEA Pennant, 1777	
Class MALACOSTRACA Latreille, 1806	
Subclass EUMALACOSTRACA Grobben, 1892	
Superorder EUCARIDA Calman, 1904	
Order DECAPODA Latreille, 1803	
Suborder REPTANTIA Boas, 1880	
Infraorder ANOMURA MacLeay, 1838	
Superfamily HIPPOIDEA Latreille, 1825	
Family ALBUNEIDAE Stimpson, 1858	
<i>Albunea</i> Weber, 1795	[13 extant, 2 fossil]
<i>Austrolepidopa</i> Efford & Haig, 1968	[2]
<i>Blepharipoda</i> Randall, 1839	[~6 extant, 1 fossil]
<i>Blepharipoda occidentalis</i> Randall, 1839	
<i>Lepidopa</i> Stimpson, 1862	[17]
<i>Lepidopa californica</i> Efford, 1971	
<i>Leucolepidopa</i> Efford, 1969	[1]
<i>Lophomastix</i> Benedict, 1904	[2]
<i>Paralbunea</i> Serène, 1979	[5]
<i>Stemonopa</i> Efford & Haig, 1968	[1]
<i>Zygopa</i> Holthuis, 1959	[2]
Family HIPPIDAE Latreille, 1825	
<i>Emerita</i> Scopoli, 1777	[~9]
<i>Emerita analoga</i> (Stimpson, 1857)	
<i>Hippa</i> Fabricius, 1787	[13]
<i>Mastigochirus</i> Stimpson, 1858	[2]

Sand crab natural history

The sand crab superfamily is comprised of more than 60 species (Table 1.1), which have a wide geographic distributed. Both *B. occidentalis* and *L. californica* are found along the coast of California, although the range of *L. californica* extends further south into Mexico. *Emerita analoga* ranges more widely, from Chile in the south to Alaska in the north, although it is not found in equatorial waters. *Blepharipoda occidentalis* is the largest of the three species, averaging ~60 mm in carapace length [Schmitt 1921] compared to ~10-17 mm for *L. californica* [Efford 1971] and ~20-35 mm for female *E. analoga* [Dugan et al. 1994].

The general biology and ecology of the three sand crab species are quite different. *Blepharipoda occidentalis* is a general scavenger living in sub-tidal zones, although it can sometimes be found in the intertidal zone [Lafferty 1993; Paul 1981; personal observations]. It is sedentary and an undistinguished swimmer at best. The general biology of *L. californica* [Efford 1971] is poorly understood, partly because it is not found in large numbers [J.E. Dugan & D.M. Hubard, personal communication]. The general biology of *E. analoga* is the best studied of the sand crabs [e.g., Cubit 1969; Dugan et al. 1994; Knox & Boolootian 1963; Macgintie 1938]. *Emerita* aggregate in the intertidal wash zone [Cubit 1969], “migrating” up and down the beach with the tides to filter-feed with their long, feather-like antenna [Knox & Boolootian 1963]. *Emerita analoga* swims by uropod beating [Paul 1971a, b, c, 1976, 1981a, b]. Although uropod beating is a novel form of locomotion, unique to the hippids, it is probably homologous to tailflipping in other decapods, including the albuneids [Paul 1971a, b, c, 1981a, b, 1991].

Survival value of digging

Digging is so fundamental to the entire biology of sand crabs that there has never been an empirical test of whether there are common functional consequences for digging across the many sand crab genera. The diverse ecology of contemporary sand crab genera suggests that digging did not evolve as a secondary adaptation in response to some earlier

innovation. Knox and Boolootian [1963] suggested that sand crabs have little competition by virtue of being diggers, but my guess is that concealment from predators is a major advantage of digging [but see Lafferty 1993], when viewed apart from other adaptations (e.g., filter feeding in *Emerita*).

Ontogeny of digging

Sand crabs spend at least several weeks as pelagic larvae [Johnson & Lewis 1942; Knight 1967, 1968; Rees 1959]. Although the thoracic legs are apparent during late zoeal stages, individuals first dig during the megalopa stage. *Blepharipoda* megalopae seem to dig like adults: they dig immediately if given sand and rarely swim [Knight 1968]. On the other hand, *Emerita* megalopae differ in their behaviour from juveniles and adults: they sometimes swim with the abdomen extended using the swimmerets, whereas juveniles and adults do not [Rees 1959; D.M. Hubard, personal communication], and they may have a slightly longer latency to dig than juveniles, particularly in turbulent water [Paul & Paul 1979].

Sand crab fossil record

The earliest known fossil decapod, *Palaeopalaemon newberryi*, is from the lower Devonian era (~400 million years ago) [Schram et al. 1978]. Although the overall body morphology incorporates both reptantian and non-reptantian characteristics [Schram 1986], the leg morphology of *P. newberryi* was very similar to contemporary astacideans (i.e., crayfish and lobsters). *Palaeopalaemon newberryi* had a large pair of claws and four pairs of slim legs, suggesting that it walked on the benthos.

The anomuran superfamilies are present in early Jurassic fossils (~180 million years ago) *except* for the sand crabs [Glaessner 1969; Schram 1982]. Sand crabs first appear in the fossil record during the middle Eocene period of the Tertiary era (~50-42 million years ago) [Beschin & de Angeli, 1984]. Two species are known from that time period: *Albunea lutetiana* Beschin & de Angeli, 1984 and *A. cuisiana* Beschin & de Angeli, 1984. The fact that these species are recognisable as belonging to an extant genus suggests that the initial sand crab diversification occurred well before the Eocene, probably during the Jurassic

anomuran radiation. The only other known fossil species, *Blepharipoda brucei* Rathbun, 1926, dates from the lower Oligocene (~38-32 million years ago) [Rathbun 1926], but it is known only from four small leg fragments [not two, *contra* Glaessner 1969]. Further, Rathbun [1926] called *B. occidentalis* the only species in its genus (see Table 1.1), as far as I know, nobody has re-examined the *B. brucei* fossils to see if they might belong to one of the other extant *Blepharipoda* species.

There are no fossils of any member of the family Hippidae. This absence is not surprising considering that hippids live in the intertidal wash zone, an environment not conducive to fossilisation [Glaessner 1969].

Although the sand crab fossil record sheds only a little information on the origin of digging, it does point out a problem in examining the evolution of a behaviour. The selective pressure which originally drove the evolution of sand crab digging need not be the same as the current selective advantages of digging (see Survival value of digging: 7); indeed, the original selective pressure may no longer be present.

The Problem

The discovery that movement patterns are homologous is the Archimedean point from which ethology or the comparative study of behavior marks its origin. [Lorenz 1981: 3]

Homology: definitions and difficulties

Whether digging and walking are homologous is a question that risks being entangled by the many meanings “homology” has in biology [Patterson 1982]. Most of the disagreement on the concept concerns whether homology should be defined as a historical relationship or a logical one (e.g., particular topological relationships between parts), but the consensus, which I agree with, favours the former [Hall 1994; Grande & Rieppel 1994]. Thus, homology denotes that features in two groups of organisms have been derived from one feature that was present in a species ancestral to both groups [Wiley 1981: 121-122]. Several points emerge by defining homology as a result of historical

events. First, because the full evolutionary history of the organisms is not directly available, a claim of homology is an hypothesis that cannot be subjected to any one, single definitive test. Second, features cannot be partly homologous: there is either continuity from a common ancestor or there is not. Third, an hypothesis about homology can only be as strong as the evidence that the species in question share a common ancestor.

Many have tried to identify a single *a priori* criterion to distinguish features that are homologous from those that are not [Lauder 1986, 1994; Striedter & Northcutt 1991]. Many people will argue that “the feature in these two taxa must be homologous if they both have the same *X*,” where *X* is some type of evidence perceived to be more reliable than the feature itself. Typical candidates are neurons for behavioural features, developmental pathways for morphological features, and genes for everything [Striedter & Northcutt 1991]. While there is no denying that these are useful clues in evaluating homology, it is wrong to think that *one* class of data can provide definitive proof of homology. First, the causal relationships between the levels of organisation (from which the data sets are drawn) are not straightforward, one to one relationships [Striedter & Northcutt 1991]. Second, evolutionary change can occur at any level of organisation [Striedter & Northcutt 1991] or stage in ontogeny [Wray 1995].

Homologous features are often, but not necessarily, similar, in which case they are examples of *static* homology. Conversely, homologous features may have changed over evolutionary time because of natural selection or chance; in either case, such features are examples of *transformational* homology [Patterson 1982; Striedter & Northcutt 1991]. Transformational homology has been criticised as a useless scientific concept, because transformational homologies are shared between taxa and, therefore, they generate no testable predictions about how the taxa in question are grouped in a phylogeny [Brady 1994; Patterson 1982]. The flaw in this argument is that an hypothesis of transformational homology generates *other* perfectly testable predictions about features that are concomitant with the putative homologues. For example, an hypothesised homology between two morphological structures would suggest that those structures may have similar functions, developmental pathways, neuronal innervation, and genes. Although any

one of these may have changed over the course of evolution, it is less likely that, if the structures were homologous, all of these related features would have been altered.

Homologies and behaviour

The concept of homology has long been applied to behaviour, although somewhat erratically. Lorenz [1970a, b, 1981] was the most prominent advocate for homologising behaviours. By doing so, the analytic and conceptual tools then available in comparative morphology could be brought to bear on behaviour. Part of his comparative work on duck courtship included one of the first efforts to construct a phylogeny using behaviour [reprinted in Lorenz 1970b]. The paper contained many ideas about phylogeny that were popularised by cladists decades later, and the proposed phylogeny holds up well when reanalysed with contemporary cladistic techniques [Burghardt & Gittleman 1990].

In discussing behavioural homology, Lorenz emphasised a particular class of behaviours, which he termed “Instinkthandlungen” (instinctive activity) or “angeborene Verhaltensweise” (innate behaviour pattern) [Martin 1970], phrases which were commonly translated as “fixed action pattern” [Thorpe 1951]. Discussion about the concept increasingly focused on stereotypy and not homology [Barlow 1968, 1977; Dawkins 1983; Pellis 1985; Reilly 1995; Schleidt 1974]. By and large, the mainstream of ethology has focused on the functional consequences of behaviour to the near exclusion of everything else [Barlow 1989; Brooks & McLennan 1991; Dawkins 1989; Stamps 1991] and studies of behavioural homologies have been few [Wenzel 1992]. Reasons for this include arguments that behaviour is inherently more variable than other biological features [e.g., Atz 1970; discussion in Greene 1994; Lauder 1986, 1990, 1994]. There is increasing empirical evidence that this is not the case, however [Clayton & Harvey 1993; de Queiroz & Wimberger 1993; Greene 1994; Langtimm & Dewsbury 1991; Winkler & Sheldon 1993]. Second, by their nature, several related species need to be studied in order to test a phylogenetic hypothesis, but crucial species may be inaccessible (e.g., due to rarity or geographic distribution). This problem is exacerbated in behavioural studies because records of living organisms are needed [Greene 1994; Lauder 1990; personal observations

concerning *L. californica*]. Third, there were not quantitative, robust, and widely recognised methods of constructing phylogenies until cladistics emerged as a standard means of estimating phylogenetic relationships [Brooks & McLennan 1991; Harvey & Pagel 1991; Gittleman & Decker 1994; Nelson & Platnick 1981]. Similarly, more types of data (especially molecular data, like DNA sequences) are being used routinely to build and test phylogenies [Hillis 1994; Lauder 1990; Novacek 1994], particularly where relationships between groups have been problematic. This has revived interest in phylogenetic studies in many fields, including behaviour. Finally, in order to generate and test phylogenetic hypotheses about behaviour, the behaviour of interest needs to be described in detail, preferably as quantitative data that can be dealt with statistically [Barlow 1989; Cocroft & Ryan 1995; Golani 1992; Greene 1994; Lauder 1986, 1994; Reilly 1995; Reilly & Lauder 1992; Smith 1994; Wainwright et al. 1989; Wishaw & Pellis 1990]. The questions of what to describe and how are complex [Drummond 1981; Fentress 1990; Jacobs et al. 1988; Pellis 1989; Tinbergen 1963], but analyses of movements and/or motor patterns are generally thought to be central. Such analyses are time consuming (although the advent of computer analyses of movement is ameliorating this), and researchers often have to design an analytic framework from scratch.

The Techniques

Well, it's a device, really — it makes the action that follows more or less comprehensible; you understand, we are tied down to a language that makes up in obscurity what it lacks in style. [Stoppard 1967: 77]

Eshkol-Wachman movement notation (EW)

Describing behaviours is a prerequisite to evaluating whether they are homologous or not. One fairly comprehensive framework for analysing movement is Eshkol-Wachman movement notation (EW). EW was developed for dance [Eshkol & Wachman 1958], and is analogous to musical notation. Just as musical notation allows a composer to record a score on paper and a musician to play the score without having heard the tune, EW permits a dance to be written down so that it can be performed by anyone who can read

the notation. Because Eshkol and Wachman did not want the notation to be tied to any particular style of dance, or for its use to be limited to dance, EW can be used to record the movements of any animal with a jointed skeleton, unlike other forms of dance notation, which are specifically tailored to the human form [Eshkol & Wachman 1958; Hutchinson Guest 1984, 1989]. EW has been used successfully to analyse the behaviour of several species of mammals [e.g., Golani 1976, 1992; Golani et al. 1981; Eilam 1994] and birds [e.g., Pellis 1983]. This work is the first to use EW to study the behaviour of invertebrates [Faulkes et al. 1991].

The general advantages and difficulties of using notational systems in dance have been discussed by Hutchinson Guest [1984, 1989], while EW's use in ethology has been discussed in Golani [1992, 1994] and accompanying commentary [including Faulkes & Paul 1992]. There are several advantages of EW. First, EW-based (or kinematic or movement-based) description of behaviour is less ambiguous than verbal descriptions, which are normally based on the presumed function of behaviour [Golani 1992; Jacobs et al. 1988]. Thus, EW is useful when functional categories of behaviour change over time, as they do during ontogeny [Fentress 1992]. Second, EW has proven to be very powerful in picking out common movement patterns across a wide range of taxa [Golani 1976, 1992; Golani et al. 1981; Jacobs et al. 1988]. Third, EW offers several different frameworks for describing movement (e.g., relative to absolute space, the animal's body, or the body of another animal), which enable one to find elements of a behaviour that are invariant, regardless of whether they are invariant with relation to extrinsic or intrinsic factors. Fourth, once a researcher knows EW, it can be applied to a wide range of experimental designs and subjects; currently, researchers studying movement must often design a means of analysing movement from scratch for each project [e.g., Kelly & Chapple 1990; Paul 1981a]. A related point is that EW requires minimal equipment: any computer-based movement analysis system costs thousands of dollars, but all a notator needs for EW analyses is a video cassette recorder or film projector with single frame capabilities, some paper, and a sharp pencil.

There are also disadvantages to using EW. First, EW is not as powerful in analysing the temporal characteristics of movements as it is for spatial ones [S.M. Pellis, personal communication]. Fine quantitative data on velocities and accelerations are difficult to extract from EW analyses, particularly in situations where the movement of a limb results from the summed movement of several limb segments. Computer-based analyses are superior in this regard. Second, EW is often criticised as being time consuming [commentary in Golani 1992]. This is true; it takes longer to notate (human) movements with EW than with other dance notation systems [Hutchinson Guest 1989]. Nevertheless, during this work, I have analysed videotape by hand with EW and using a computer-based movement analysis package (Peak 5; Peak Performance Technologies). My impression is that working on the computer is moderately faster, but the speed of data input is a relatively minor advantage.

A brief description of how EW is written is contained in Appendix A: Eshkol-Wachman movement notation (pg. 259), and a bibliography is contained in Appendix B: An annotated bibliography of Eshkol-Wachman movement notation (pg. 263).

Electromyograms (EMGs)

Regardless of the power of a detailed movement analysis, there is not a simple relationship between movement and the output of a nervous system [Bernstein 1984]. The final shape of a movement is a product of the nervous system's output *plus* other physical factors such as the torques generated at other joints, momentum, external loads placed on the limb, or gravity [Faulkes & Paul 1992; Hubbard 1960]. Electromyograms (EMGs) are records of electrical activity generated by muscles, and provide a picture of the central nervous system's output that is basically divorced from the physical variables shaping limb movement. Thus, EMGs and EW provide complementary information on motor patterns.

The temporal resolution of EMGs can be as fine as milliseconds. Such resolution makes EMGs a particularly valuable supplement to an EW analysis, because EW's temporal resolution is restricted by the sampling frequency of the film or videotape used to record the movement. For videotape, the temporal resolution is limited to 33.3 ms (North

American NTSC format) or 40 ms (European PAL format). Some video cassette players can play tapes at 60 fields per second (a resolution of ~16.5 ms), the increased temporal resolution comes at a loss of spatial resolution. Higher frame rates can only be attained through high speed video or film, both of which are expensive.

In crustaceans, individual neuron activity can be distinguished on the basis of the size of the EMG potentials in some cases [Ayers & Clarac 1978; Clarac et al. 1987]. One limitation of EMGs, however, is that they normally cannot record the effects of inhibitory motor neurons [Clarac et al. 1987; Dudel & Kuffler 1961], which are well documented in crustaceans [Atwood 1976; Wiens 1989; Spirito 1970].

Overview

Chapters 2, 3, and 4 describe sand crab digging behaviour, with the first two chapters dealing almost exclusively with the thoracic legs. Chapter 2 characterises the general form of the digging leg movements and the coordination between the digging legs in *B. occidentalis*, *L. californica*, and *E. analoga*. The gross movements of the legs and the coordination between them is generally similar in the three species, with some notable familial differences. One feature common to all three species is that the movements of legs 2 and 3 are different from those of leg 4. This finding is examined in Chapter 3, which shows that in *B. occidentalis* and *E. analoga*, these different tip trajectories are due to the different patterns of interjoint coordination of each single leg. Chapter 4 examines the coordination of the legs with the "tail" (the abdomen in *B. occidentalis* and *L. californica*; the uropods in *E. analoga*), which expands on some of the familial differences found in Chapter 2.

Chapters 5 and 6 describe some preliminary efforts to characterise the neural circuitry controlling the digging legs. Chapter 5 details unsuccessful attempts to elicit rhythmic motor output from isolated nerve cords. Chapter 6 describes the numbers and central morphology of distal leg motor neurons in *B. occidentalis*, *E. analoga*, and two walking species. There are no gross segmental or species differences in the central morphologies of the distal leg motor neurons in any of the four species studied, suggesting

that changes in connections between neurons or neuron physiology are responsible for segmental differences in the motor output of sand crab legs, and for the species differences between walking and digging taxa.

Chapter 2: Interleg coordination¹

Me habéis preguntado qué hila el crustáceo entre sus patas de oro
y os respondo: El mar lo sabe.

You ask me what the crab weaves with its legs of gold,
and I respond: The ocean knows this.

[Neruda 1950 and translation]

Introduction

Walking is almost certainly the ancestral form of locomotion using the legs in decapods [Hessler 1985]. The leg morphology of the earliest known decapod, *Palaeopalaemon newberryi* [Schram et al. 1978], resembles modern astacideans (crayfish and lobsters), whose locomotion has been well studied [Ayers & Davis 1977; Cruse 1990; Evoy & Ayers 1982; Jamon & Clarac 1995; Macmillan 1975; Müller & Cruse 1991; Pond 1975; Sillar et al. 1987]. Palinurans [e.g., spiny lobsters; Chasserat & Clarac 1983; Clarac & Chasserat 1983; Clarac 1984; Müller & Clarac 1990a] and thalassinideans (e.g., mud shrimps) are apparently similar in many respects, but there is tremendous diversity in walking behaviour within the reptantians. Most brachyuran crabs walk sideways almost exclusively [Burrows & Hoyle 1973; Clarac 1977; Clarac et al. 1987; Evoy & Fournier 1974; see Sleinis & Silvey 1980 for an example of a forward walking crab], and some can swim using the legs [Hartnoll 1970; Spirito 1972]. Within the anomurans, squat lobsters and porcelain crabs (Superfamily Galattheoidea) apparently walk in any direction with equal ease, and hermit crabs (Superfamily Paguroidea) walk while carrying gastropod shells [Herreid & Full 1986]. Sand crabs are unusual because they have lost the ability to walk altogether and use their legs to dig into sand instead. A natural supposition is that digging may be homologous to walking: both are rhythmic forms of locomotion using the

¹ Abstracts based on material in this chapter have been published [Faulkes & Paul 1992; Faulkes et al. 1991].

thoracic appendages, and the taxa most closely related to the sand crabs, the squat lobsters and porcelain crabs (Galatheoidea) still walk. The interleg coordination in the mole crab (*Emerita* spp.; family Hippidae), however, differs from walking patterns in most other decapods. The fourth pair of legs cycles at approximately double the frequency of the second and third pair [Trueman 1970] and move laterally rather than in an anterior-posterior plane [Knox & Boolootian 1963]. Such differences in frequency of leg movements are seen in other animals in which the sizes of legs differ dramatically (e.g., locusts), but the digging legs of sand crabs are similar in size (except for the small fifth leg, which is not used in locomotion; this is typical of anomurans). These differences in coordination may argue against the homology of walking and digging. Digging by *Emerita* may not be representative of the sand crabs as a whole, however. The hippid tailfan, for example, is highly modified for uropod beating, whereas the albuneid tailfan morphology and related behaviours are more similar, but not identical, to macruran decapods [Paul 1981a, b; 1991]. Further, interleg coordination has only been described in general terms for the ipsilateral legs, and not at all for the bilateral pairs of legs [Trueman 1970].

I examined the digging leg movements of sand crabs of both families, focusing on the spiny sand crab, *Blepharipoda occidentalis* (Albuneidae), the pearly sand crab, *Lepidopa californica* (Albuneidae), and the mole sand crab, *Emerita analoga* (Hippidae).

Methods

The sand crabs *Blepharipoda occidentalis* Randall, 1839 and *Emerita analoga* (Stimpson, 1857) were collected during low tide in Monterey Bay, California; *Lepidopa californica* Efford, 1971 were collected at low tide on beaches near Santa Barbara, California. Squat lobsters, *Munida quadrispina*, were collected by trawling from the MSSV *John Strickland* in Saanich Inlet, Vancouver Island, British Columbia. All were housed in the University of Victoria's recirculating, ~11°C seawater system.

I videotaped *M. quadrispina* walking and *B. occidentalis* and *E. analoga* making digging movements in water using a Panasonic Super-VHS PV-S770 camera (NTSC format; 30 frames per second). This camera has an electronic "shutter" so that the

exposure time for each frame was <1 ms of the 33.3 ms interval between frames, and the image within an individual frame was sharp. I placed a mirror in the bottom of the filming tank, angled at 45° to the camera, to film side and ventral views of the animals simultaneously. Because *L. californica* is the smallest species of the three sand crabs, *L. californica* were videotaped slightly differently, resulting in a lower recording quality than for *B. occidentalis* or *E. analoga*. Individuals were videotaped using a Panasonic WV-CP210, which has a shorter focal distance but no electronic shutter. To get as large an image of the animal as possible, *L. californica* was videotaped from only one view (side or ventral) at a time.

The videotape was analysed frame by frame. Most analyses were done by hand; for example, leg tip trajectories were traced from the video screen on to transparent acetate, and movements were recorded on paper, sometimes using symbols from Eshkol-Wachman movement notation [Eshkol 1980; see Appendix A: Eshkol-Wachman movement notation: 259]. Once I had determined what the patterns of movement were, I re-examined other digging sequences to see if the same pattern was evident. After establishing what the movement patterns were, I digitised some videotaped sequences of leg movement of *B. occidentalis* and *E. analoga* with the Peak 5 movement analysis system (Peak Performance Technologies, Inc.; 60 fields per second) to obtain quantitative data on displacement and speed.

Because I could not videotape animals actually digging in sand, I recorded electromyograms (EMGs) from the leg and abdominal muscles of digging animals. I drilled small holes in a sand crab's exoskeleton, and inserted two fine ($76.2\mu\text{m}$) silver wire electrodes, insulated with Teflon except for the tip, into the leg muscles of interest. I glued the electrodes in place at the wire's entry point. Some electrode placements were confirmed by post-experimental dissection. EMGs were recorded on a Vetter D1 reel to reel frequency modulated (FM) tape recorder, and later transferred to an IBM-PC compatible computer using a Labmaster TL-1 analogue/digital converter and the software package Axotape 2 (Axon Instruments, Inc.).

Decapod crustaceans have five pairs of thoracic legs. In most reptantians, the first pair of legs is usually a pair of large claws specialised for defence and not used in locomotion. Occasionally, researchers refer to the “walking legs” and exclude the claws from the numbering scheme; i.e., the third pair of legs is referred to as the second pair of walking legs, and so on. Here, all legs are numbered from anterior to posterior, so that the claws (in species that have them) are termed “leg 1.” Left and right legs are designated by L and R. In anomurans, the fifth, most posterior pair of legs (leg 5) is greatly reduced in size and are used for cleaning the gill chamber and brooding eggs rather than locomotion [Haig & Abbott 1980; this has occasionally lead to the third maxilliped being misidentified as a leg; e.g., Fig. 1 in Hill 1979]. Consequently, the movements of leg 5 were not analysed. Similarly, although leg 1 contributes to digging, sand crabs do not to make a full range of movements with leg 1 when held in water, so leg 1 was not examined in detail.

Data treatment

In studies of rhythmic behaviour, the *period* is the duration of one complete cycle of events. The relative timing between two repeating events is expressed as *phase* (ϕ), calculated as $\phi = (\text{Onset}_{\text{Text}} - \text{Onset}_{\text{Reference}}) / \text{Period}_{\text{Reference}}$. Phase is a “circular” measurement: a phase of 0 and 1 both mean that two events began at the same time, or are synchronous.

Traditionally in locomotor research, a complete cycle of leg movement is divided into a power stroke (when the limb is providing propulsive force to move the animal’s body; this is also known as “stance phase” in walking studies, because the leg touches the substrate) and a return stroke (when the limb is not providing propulsive force; also known as “swing phase,” raised off the substrate). In this case, I could not divide digging leg movements into power and return strokes *a priori* because a sand crab’s legs move through the substrate as it digs. Power and return strokes were determined by examining leg tip trajectories of digging movements made in water. The most rapid leg movements defined the power stroke, because such movements would provide the propulsive force in an aquatic medium. Slower leg movements in water defined the return stroke. During

actual digging, however, these relative speeds may be reversed, because the resistance of the sand may impede the leg sufficiently to make the power stroke slower than the return stroke.

Results

Tip trajectories

The tip trajectories of homologous legs are similar in all three sand crab species. The tip trajectories of legs 2 and 3 resemble each other but are both different from leg 4. When viewed from the side, the tip of leg 4 circles in the opposite direction to legs 2 and 3; that is, when viewing the right side of an animal, leg 4 circles clockwise while legs 2 and 3 circle counterclockwise. This difference in tip trajectory is not simply due to the different shape of leg 4, but results from a very different sequence of joint movements (See Chapter 3, Interjoint coordination: 83). The “reversed” tip trajectory of leg 4 compared to legs 2 and 3 causes an animal’s rear end to be pushed down into the sand. If leg 4 circled in the same direction as legs 2 and 3, the resulting force would tend to propel an animal straight backwards, much like albuneids swimming using legs 2 and 3, but not 4, while tailflipping.

The cycle of legs 2 and 3 consists of a power stroke, where the leg swings forward and away from the body rapidly, with the dactyls in an “open” position so that the broad surface faces forward, increasing the legs’ drag on the sand. During the backward-directed return stroke, the leg is brought closer to the body with the dactyls in a “closed” position, thereby decreasing any drag on the sand. In *B. occidentalis*, the return stroke speed of legs 2 and 3 is much slower than the power stroke (Figure 2.4), but in *E. analoga*, the two portions of the cycle can be nearly the same speed during very hard digging (Figure 2.5). Legs 2 and 3 act like shovels, scooping the sand out from underneath the animal.

The movement of leg 4 is not as easily divisible into power and return strokes as legs 2 and 3 for several reasons. The overall movement of leg 4 is much more variable than that of legs 2 and 3: leg 4 will sometimes be held still even while legs 2 and 3 are moving vigorously, which often occurs when *B. occidentalis* or *L. californica* are

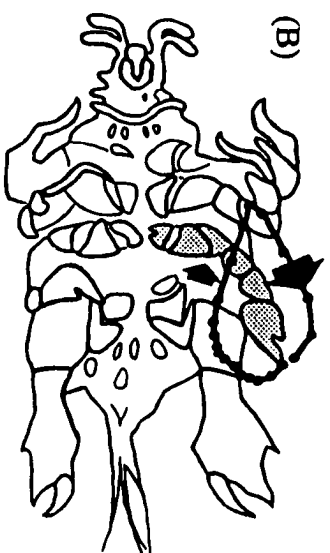
swimming by rowing their legs. Even when leg 4 makes relatively large amplitude movements (which are much smaller excursions than those made by legs 2 and 3 in all three species; Figure 2.1 to Figure 2.3), its speed is more uniform than legs 2 and 3 (Figure 2.4, Figure 2.5). Secondly, the most rapid movement in leg 4 occurs when the leg is changing directions from backward to forward, when the leg tip is at its most posterior (Figure 2.4). Third, the tip trajectory is more complicated than legs 2 and 3, incorporating a substantial lateral component, and, therefore, is not easily represented in two dimensions (Figure 2.1E-F). The most rapid movement tends to occur when the leg tip is moving up, laterally away from the midline, and making a transition from backward to forward movement. The power stroke of leg 4 will be defined by its forward component, to be comparable with legs 2 and 3, because the power and return strokes of legs 2 and 3 are defined by their anterior-posterior movement. The smaller, but more complicated excursions of leg 4 (plus, in *E. analoga*, its small size) suggests that it contributes to digging mainly by creating a thixotropic effect [i.e., liquefying the sand; Cubitt 1969] rather than pushing directly on the sand. Leg 4 acts more like a spoon stirring a cup of coffee than a shovel.

Figure 2.1: *B. occidentalis* leg tip trajectories

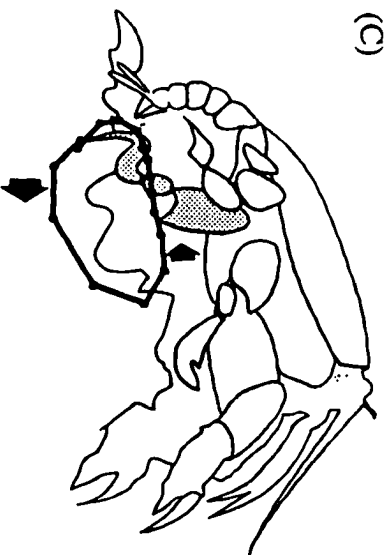
In *B. occidentalis*, the leg tip trajectories of legs 2 and 3 are in opposite directions to leg 4. Dots show position of dactyl tip traced from video. (A) Leg 2 viewed from side. (B) Leg 2 viewed ventrally. (C) Leg 3 viewed from side. (D) Leg 3 viewed ventrally. (E) Leg 4 viewed from side. Unlike legs 2 and 3, the tip of leg 4 circles clockwise in this view. (F) Leg 4 viewed ventrally. All figures traced from the same video sequence. Time between dots = 33.3 ms (i.e., one video frame).



(A)



(B)



(C)



(D)



(E)



(F)

Figure 2.2: *L. californica* leg tip trajectories

Lepidopa californica leg tip trajectories are similar to *B. occidentalis*. Dots show position of dactyl tip traced from video. (A) Leg 2 viewed from side. (B) Leg 2 viewed ventrally. (C) Leg 3 viewed from side. (D) Leg 3 viewed ventrally. (E) Leg 4 viewed from side. (F) Leg 4 viewed ventrally. Dashes in *A* and *C* indicate blurring of the image due to rapid movement of the limb (see Methods). Antennae truncated. *A*, *C*, and *E* are not traced from the same video sequence as *B*, *D*, and *F*. Time between dots = 33.3 ms (i.e., one video frame).

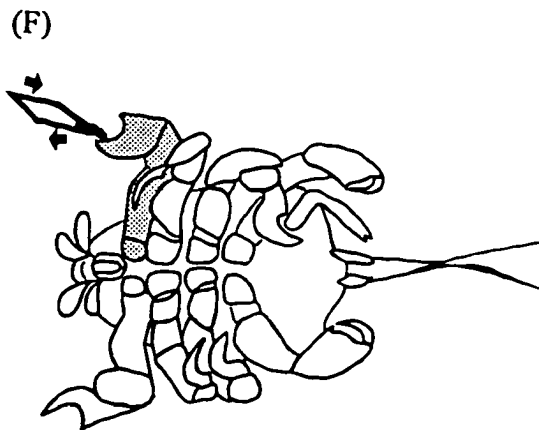
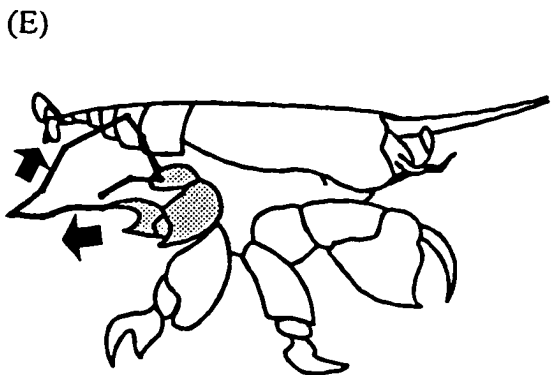
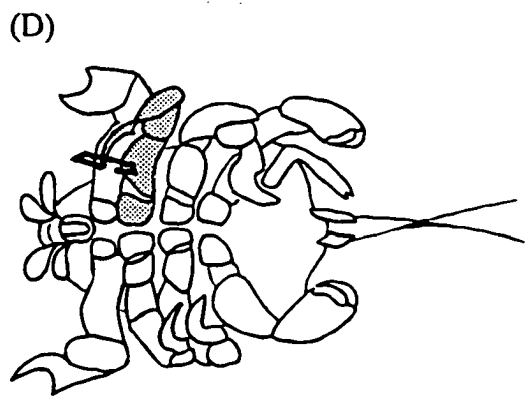
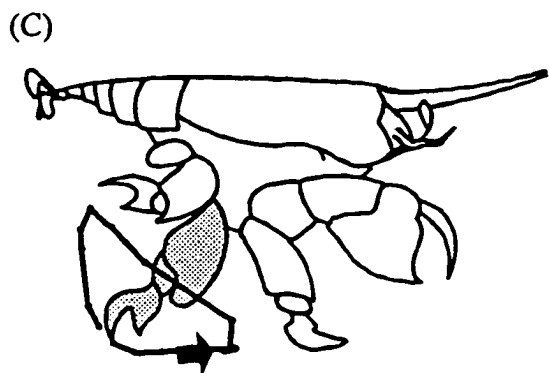
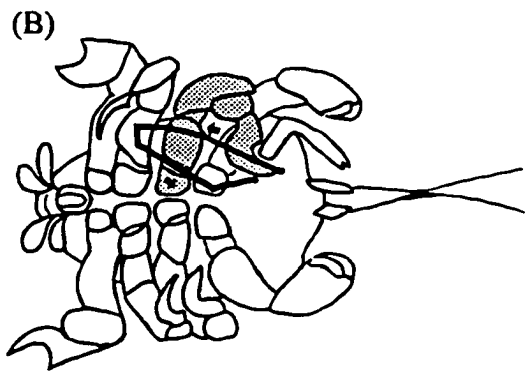
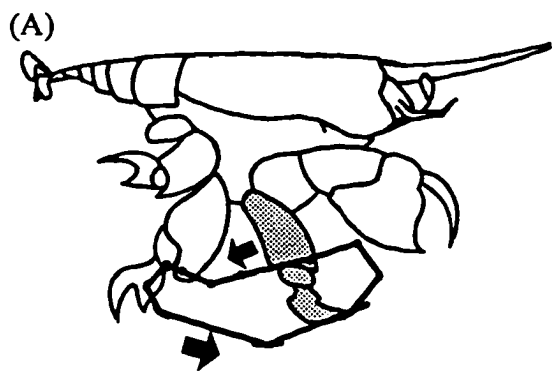
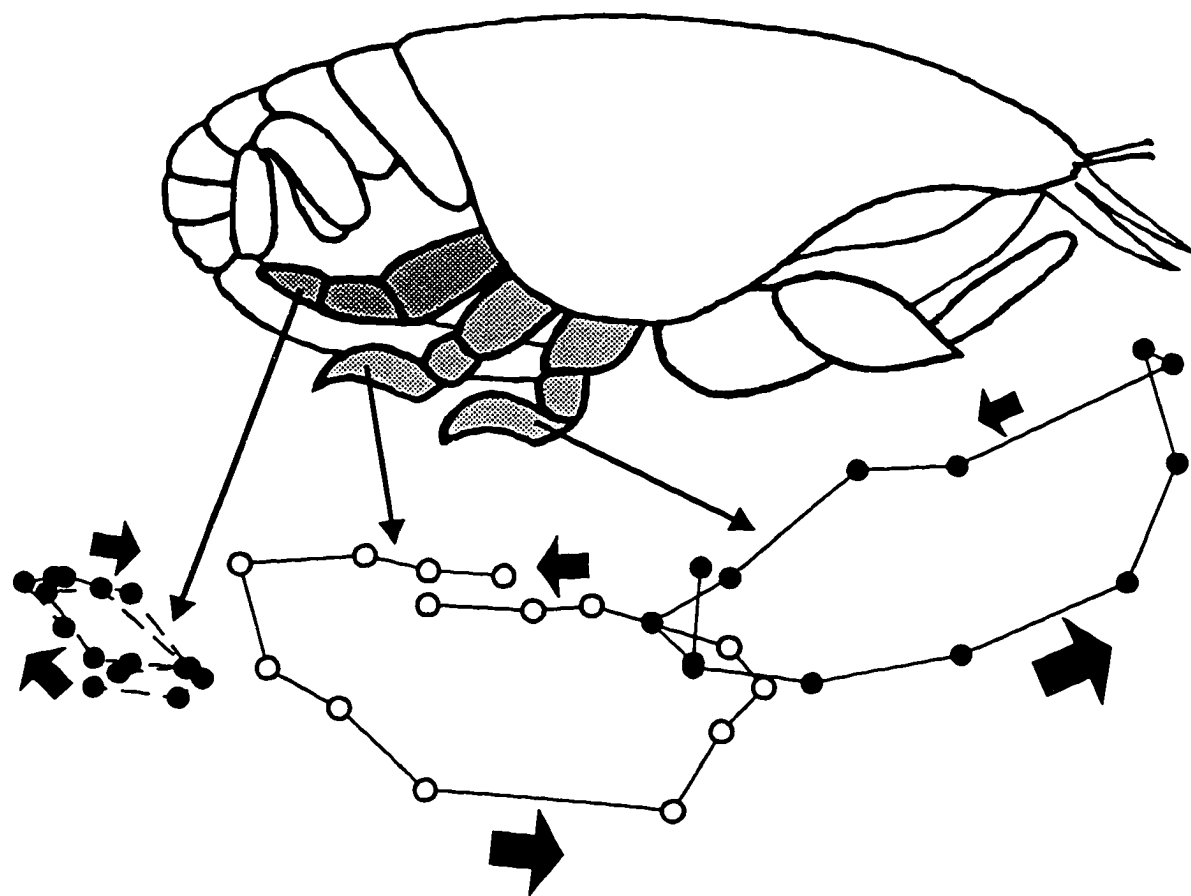


Figure 2.3: *E. analoga* leg tip trajectories

Emerita analoga leg tip trajectories are similar to the albuneids', but with slightly less overlap. Dots show position of dactyl tips. Topology of tip trajectories is correct relative to each other, but only approximately to picture of *E. analoga*. Notice that leg 4 has cycled around twice in the time that legs 2 and 3 have completed only one cycle. Time between dots = 16.7 ms (i.e., one video field; digitised using Peak 5). Scale bar = 1 cm (tip trajectories only; size of *E. analoga* picture slightly smaller scale).



- Leg 2
- Leg 3
- Leg 4



Figure 2.4: Leg tip velocity during forward and backward movements in *B. occidentalis*

Horizontal movements (i.e., forward and backward movement) and speed of legs in *B. occidentalis*. Combined plot of horizontal movement (line and symbol) and speed (line only) of (A) leg 2, (B) leg 3, and (C) leg 4. On the left axis (horizontal displacement), larger numbers are towards anterior of animal. The highest velocities of leg 2 and 3 occur during the forward movement, whereas the most rapid movement of leg 4 occurs during a movement that changes direction from backward to forward. The velocity of leg 4 is lower and more variable than leg 2. Total time = 2 s.

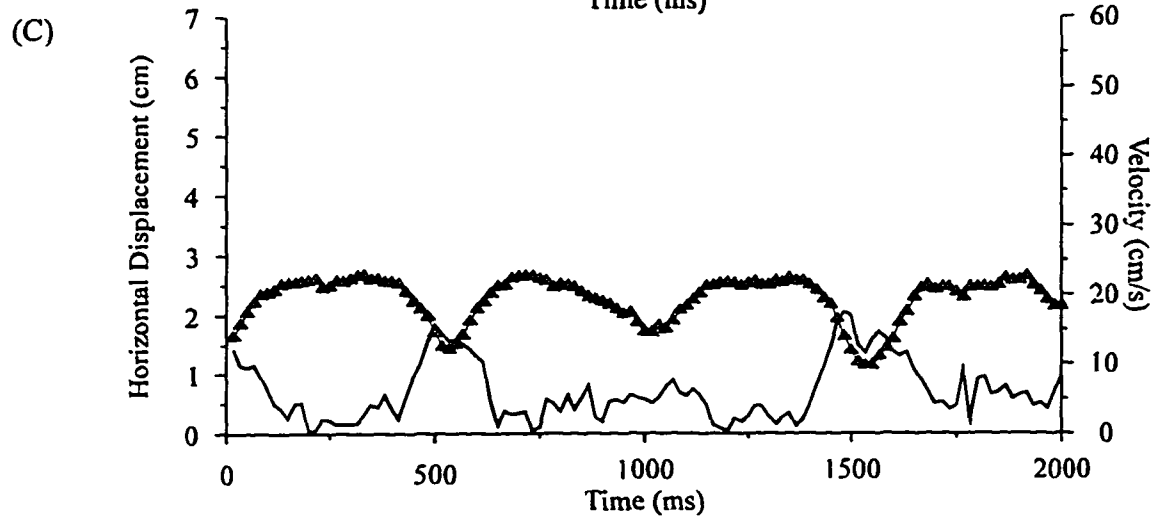
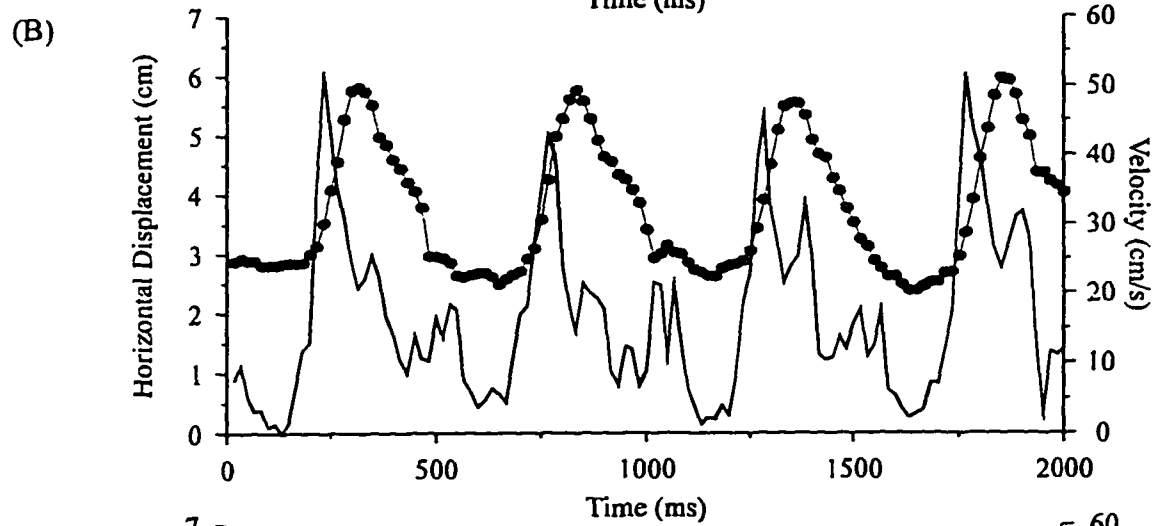
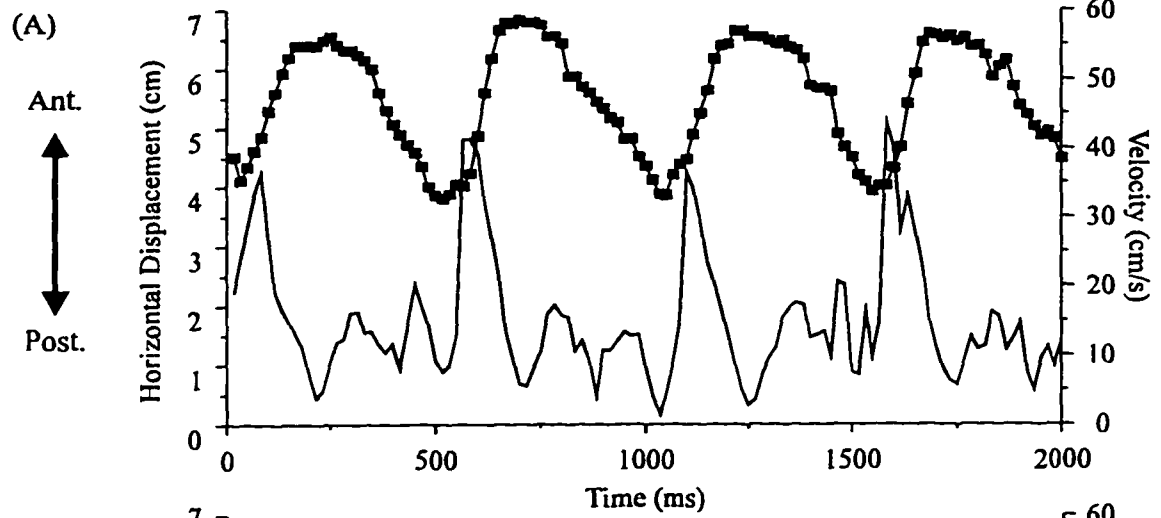
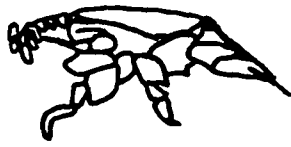
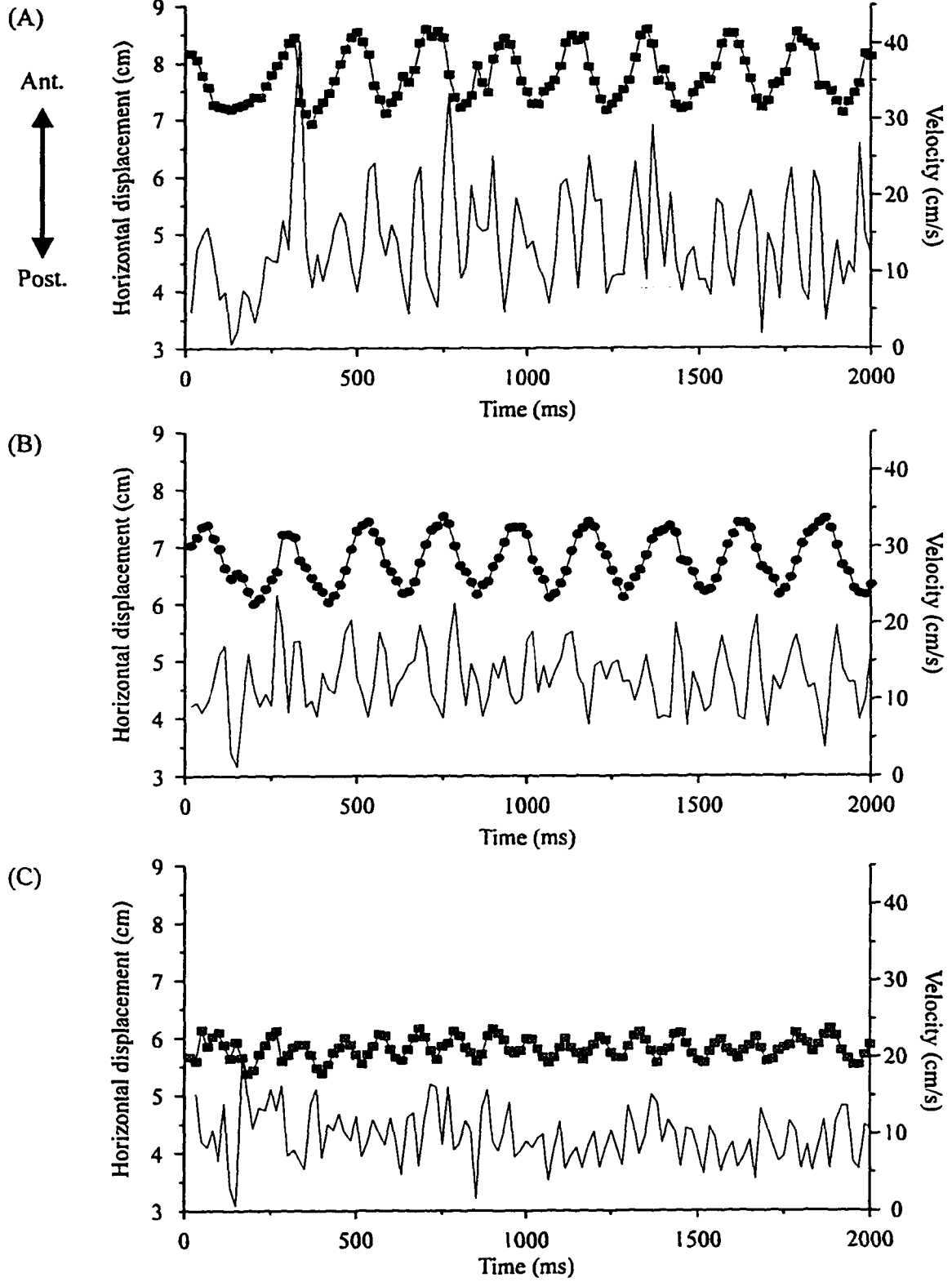


Figure 2.5: Leg tip velocity during forward and backward movements in *E. analoga*

Horizontal movements (i.e., forward and backward movement) and speed of legs in *E. analoga*. Combined plots of horizontal movement (line and symbols) and speed (line only) of (A) leg 2, (B) leg 3, and (C) leg 4. On the left axis (horizontal displacement), larger numbers are towards anterior of animal. The power and return strokes in legs 2 and 3 are almost equal in velocity. Note the greater frequency of leg 4. Total time = 2 s.

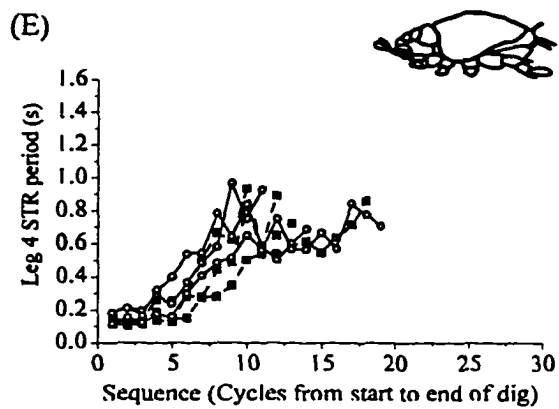
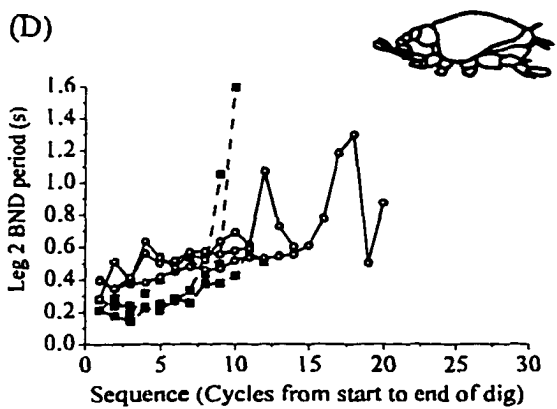
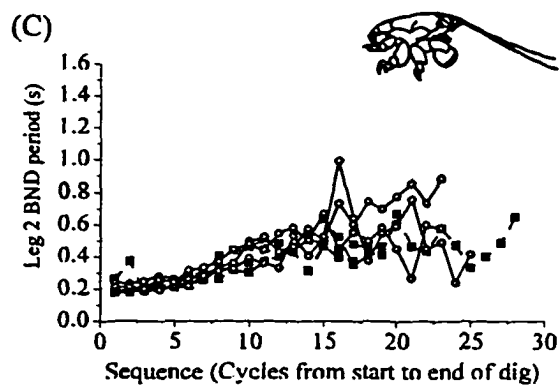
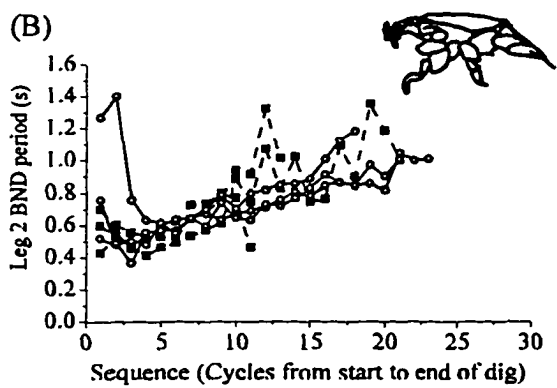
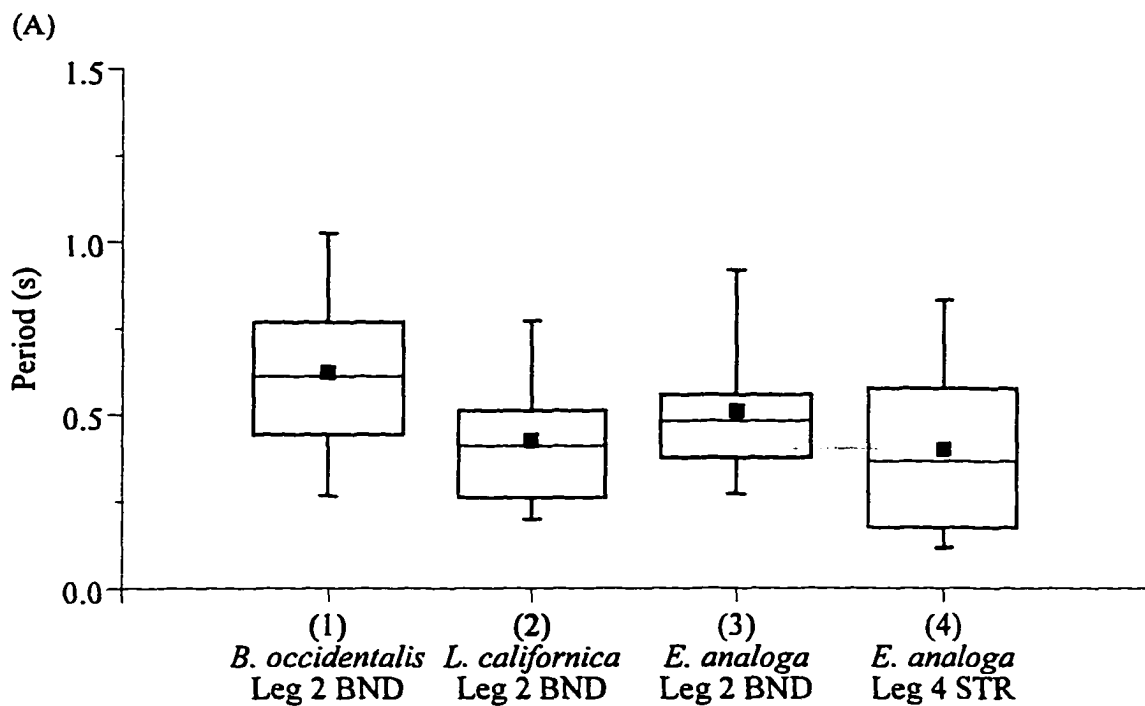


Speed

The leg movements are slower (i.e., fewer digging cycles per second) in *B. occidentalis* than in *E. analoga*, and the leg movements in *E. analoga* are in turn slower than in *L. californica*. When making digging movements in water, the legs cycle back and forth at frequencies of ~1.5-2 Hz in *B. occidentalis*, ~3-4 Hz for leg 2 and 3 in *E. analoga* (leg 4 is faster, ~3-8 Hz; see Figure 2.7), and ~4-7 Hz in *L. californica*. This rank persists when animals dig (Figure 2.6A), but the differences are minimised because all three species slow down as they dig, probably due to the sand's resistance (Figure 2.6B-E).

Figure 2.6: Speed of *B. occidentalis*, *L. californica*, and *E. analoga*

Relative speeds of the three sand crab species. (A) Box chart of EMG periods of the three sand crab species from (1) leg 2 bender EMGs in *B. occidentalis* (three digs each from three animals), (2) leg 2 bender EMGs in *L. californica* (three digs each from two animals), (3) leg 2 bender EMGs in *E. analoga*, (4) leg 4 stretcher muscle in *E. analoga* (three digs each from three animals). The four means are significantly different (One-way ANOVA, $f = 30.1$, $p < 0.05$). Abbreviations: BND = bender muscle, STR = stretcher muscle. Symbols: bottom vertical line = 5th percentile; box bottom = 25th percentile; ■ = mean; middle box line = 50th percentile (i.e., median); box top = 75th percentile, top vertical line = 95th percentile. (B-E) Sand crabs slow down as they dig. Sequential periods of EMG bursts in (B) leg 2 bender muscle in *B. occidentalis*, (C) leg 2 bender in *L. californica*, (D) leg 2 bender in *E. analoga*, (E) leg 4 stretcher in *E. analoga*. Each graph in B-E shows three digs each from two individuals (filled and empty symbols).



Ipsilateral coordination

In arthropods, coordination of ipsilateral limbs is generally stronger than bilateral coordination [Cruse 1990; Jamon & Clarac 1995], and sand crabs conform to this general pattern.

Munida quadrispina

Munida quadrispina is a member of the superfamily (Galatheoidea) thought to be most closely related to sand crabs. Therefore, *M. quadrispina* is a good candidate for having a walking pattern like that of a non-digging sand crab ancestor. Like sand crabs, *M. quadrispina* uses legs 2, 3 and 4 for locomotion, and it tends to walk using an alternating tripod gait (Figure 2.7A). During walking, legs 2 and 4 on one side of the body and the contralateral leg 3 normally support the body. This pattern has been reported many times in a variety of hexapedal animals, notably insects [Wilson 1966]. Palinuran crustaceans often walk using an alternating tripod gait, but walk on legs 3, 4 and 5 [Clarac 1984].

Observations of the animals in the lab and of some videotaped sequences suggested there were no marked differences between walking by squat lobsters and more commonly studied astacideans and palinurans, so *M. quadrispina* walking was not examined further.

Blepharipoda occidentalis

The forward and backward movements of the legs in *B. occidentalis* are grossly similar to leg movements of *M. quadrispina* in that legs 2 and 4 move forward at about the same time (Figure 2.7B). Legs 2 and 3 are strongly coupled, with leg 3 moving forward after leg 2 ($\phi_{3 \text{ in } 2} \approx 0.2$; Figure 2.8). This phasing is closer to synchrony than usually seen in adjacent legs of walking species [Evoy & Fournier 1973; Jamon & Clarac 1995; Macmillan 1975], and probably increases drag during the forward movement of the legs and reduces drag during the backward movements. Considering the large excursions made by the legs (Figure 2.1), a higher phase (e.g., $\phi \approx 0.5$) would cause a backward moving leg 2 to collide with a forward moving leg 3. Thus, legs 2 and 3 go backwards

together, which can be seen in how these two legs form and break “oppositions” [a topological arrangement where two limbs are near but not touching; Eshkol 1980]: the two legs form an opposition when leg 3 stops moving forward, which is “broken” when leg 2 starts to move forward.

As noted above, the movement of leg 4 is much more variable than legs 2 and 3 when animals are held in water, sometimes making only minimal movements. The coupling of leg 4 with legs 2 and 3 may be less crucial than it is between 2 and 3 because the tip trajectory of leg 4 does not overlap with the others (Figure 2.1), so there is little risk of legs colliding regardless of their phasing. Large, regular EMGs are recorded when an individual is actually digging, however, suggesting substantial movements of leg 4.

Lepidopa californica

The coordination of ipsilateral legs in *L. californica* is only subtly different from *B. occidentalis* (Figure 2.7C). Legs 2 and 4 move forward at about the same time, although there is a tendency for the forward movement of leg 4 to precede that of leg 2. The movements of legs 2 and 3 tend to be coupled and, like *B. occidentalis*, there are many times when legs 2 and 3 in *L. californica* are moving rapidly and leg 4 is not moved at all. Legs 2 and 3 are coupled, with leg 2 leading leg 3, but the coupling between them appears to be slightly weaker than in *B. occidentalis*: the movement of leg 3 is sometimes much smaller in amplitude and more variable than leg 2 (e.g., compare Figure 2.2C with Figure 2.2D), particularly when leg 4 is moved. Despite this, the same topological relationships between legs 2 and 3 (i.e., oppositions) are seen in *L. californica* as in *B. occidentalis*.

Emerita analoga

The movements of legs 2 and 3 are very similar in *E. analoga* and the two albuneids (Figure 2.7D), with close coupling between the two, the forward movement of leg 2 leading that of leg 3, and oppositions forming when leg 3 stops moving forward.

The coordination of leg 4, however, is very different in *E. analoga* than the albuneids. In both albuneids, leg 4 moves back and forth at approximately the same

frequency as legs 2 and 3 (Figure 2.7B, C). In *E. analoga* and *E. portoricensis* [Trueman 1970], leg 4 can move back and forth at about double the frequency of the other legs, at approximately the same frequency as the beating of the uropods (Figure 2.18). Such “double time” movement by leg 4 is very difficult to elicit when an animal is held in water, because *E. analoga* tends to swim by uropod beating if nothing touches the legs. Nevertheless, the high frequency of leg 4 was regularly recorded by EMGs from digging animals, particularly early in a digging sequence. EMGs also showed that leg 4’s frequency tends to drop to approximately that of legs 2 and 3 as an individual became submerged in the sand.

Although leg 4 slows to approximately the same speed as legs 2 and 3, the data concerning its phase coupling with legs 2 and 3 are equivocal (Figure 2.10). There are several possible explanations for this. Most obviously, EMGs were recorded from different muscles in the two data sets, and the timing of some muscles (particularly in leg 4) may be more variable than others. There is little evidence of such variability in multiple EMGs recorded within a single leg, however (see Chapter 3, Interjoint coordination: 83). Another possibility is that these are individual differences: different individuals provided the data for the stretcher muscle (Figure 2.10A-B) and the depressor muscle (Figure 2.10C-D), and the former were more heterogeneous. The differences between individuals could be biological, but are more likely to be artefacts of particular recording situations. Regardless of the amount of phase coupling between leg 2 and 4, it is clearly much weaker than between legs 2 and 3.

Figure 2.7: Power and return strokes

Movement of limbs forward (boxes) and backward (lines) relative to the body in (A) *M. quadrispina* walking backwards, (B) *B. occidentalis*, (C) *L. californica*, and (D) *E. analoga* making digging movements while held above sand. Breaks indicate limb was still. Shaded boxes highlight a representative cycle of locomotor movements. Abbreviations: AB = abdomen; UR = uropods. Symbols [Eshkol 1980; Appendix A, Eshkol-Wachman movement notation: 259]: \uparrow = leg touching substrate; \sqcap = pair of limbs forming an opposition (i.e., close but not touching); “=” = release of opposition. Temporal resolution: A & C = 33.3 ms, B & D = 16.7 ms (digitised using Peak 5). Scale bars: A = 1 s, B-D (shown in B) = 200 ms.

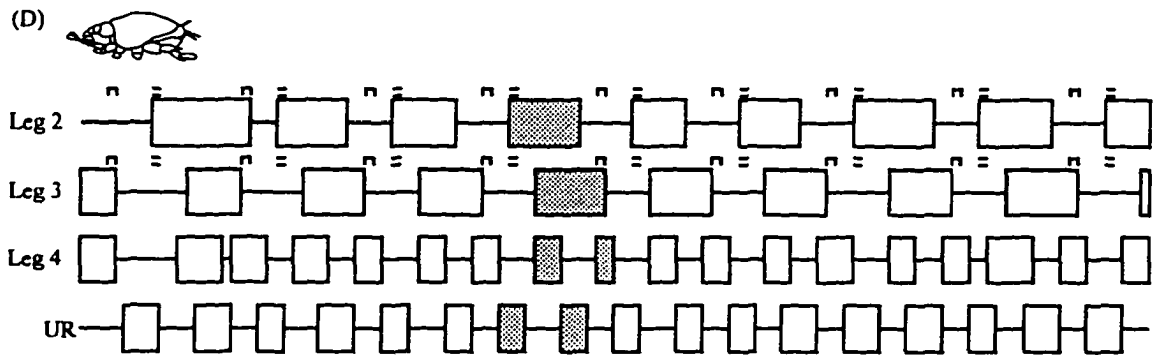
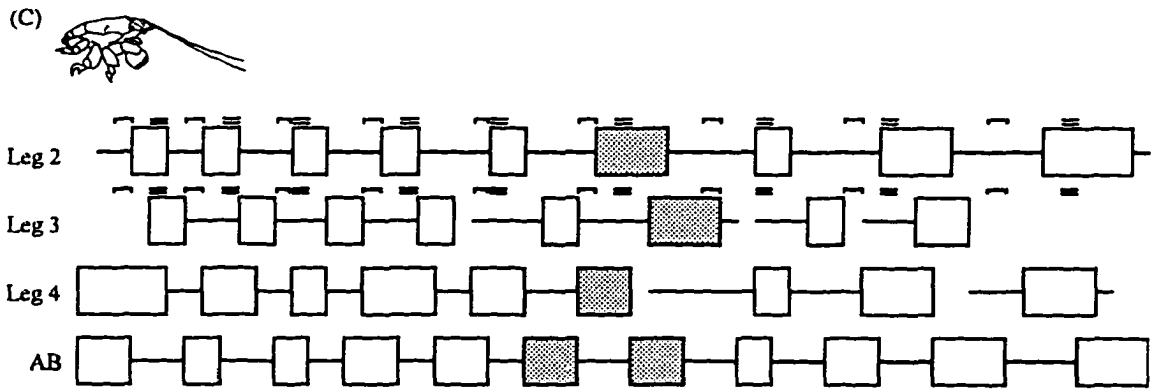
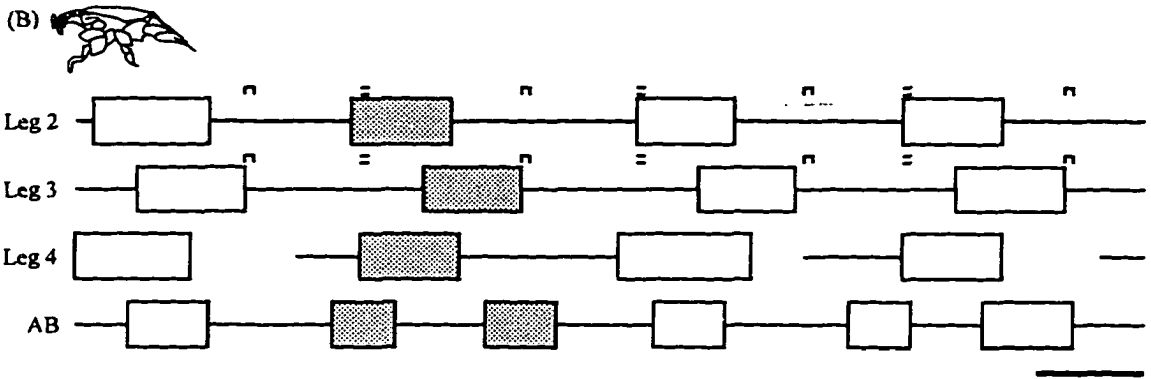
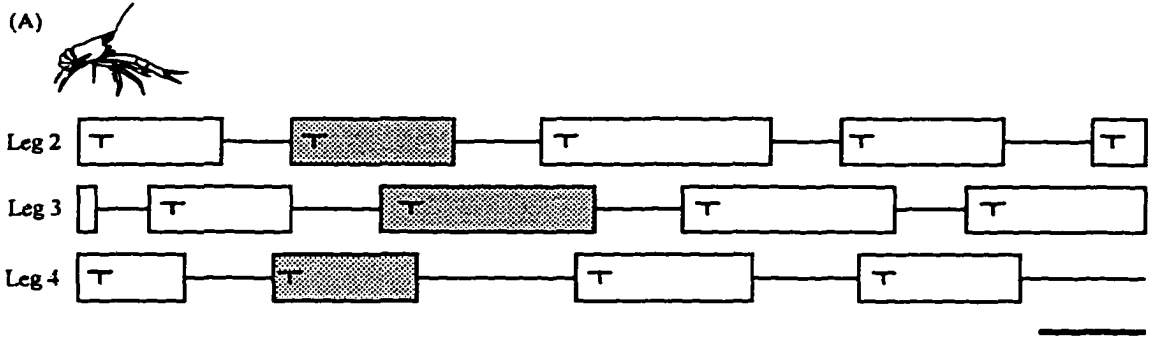
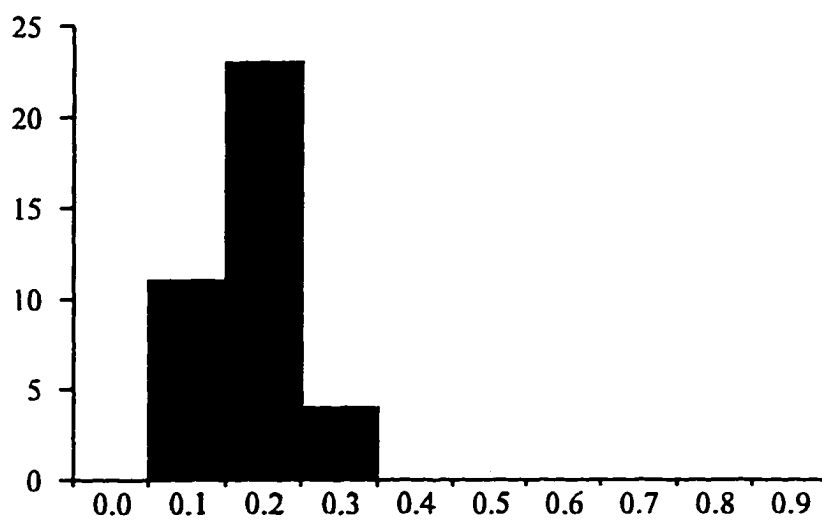


Figure 2.8: Coupling of legs 2 and 3 in *B. occidentalis*, *L. californica*, and *E. analoga*

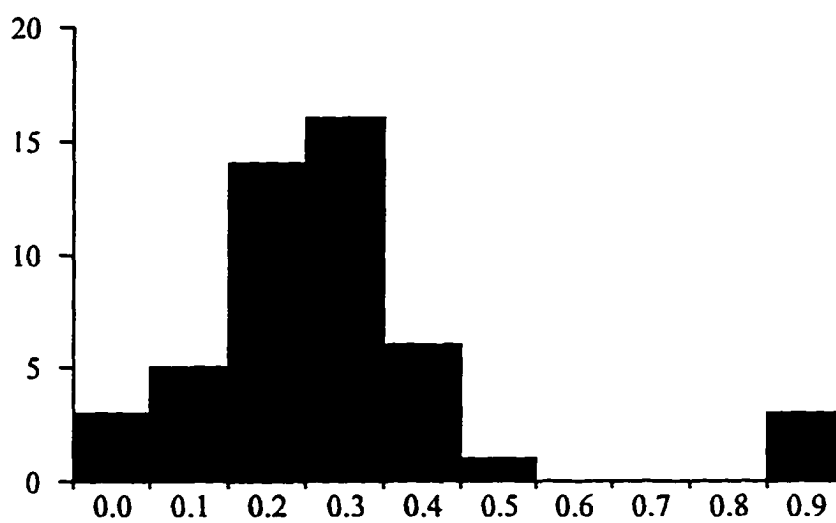
Coupling of legs 2 and 3 in water. Phase histograms of forward movement of leg 3 relative to forward movement of leg 2 in (A) *B. occidentalis*, (B) *L. californica*, and (C) *E. analoga*. Sample sizes: A = six “swimming” sequences from six animals; B = six sequences from at least three individuals; C = eight sequences from at least three individuals.



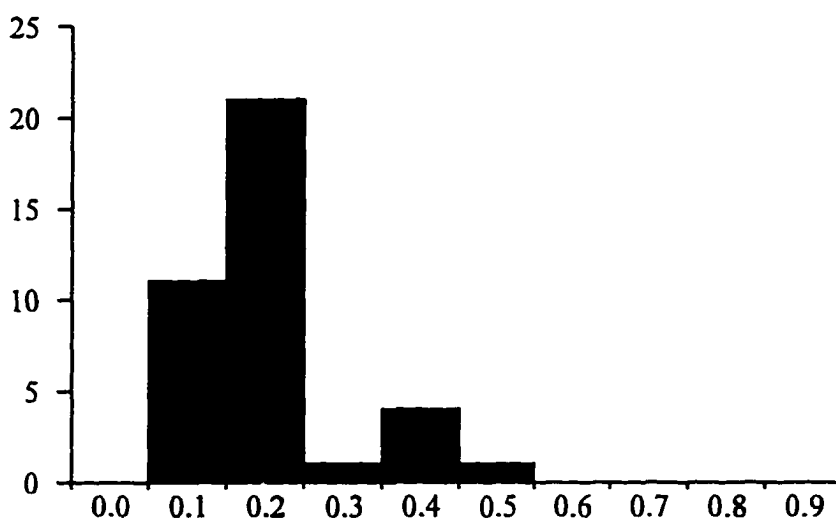
(A)



(B)



(C)



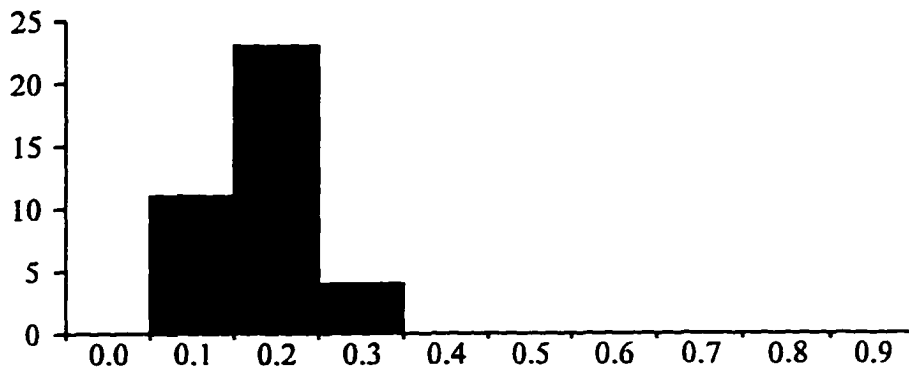
ϕ Leg 3 in 2

Figure 2.9: Coupling of legs 2 and 3 during digging by *B. occidentalis*

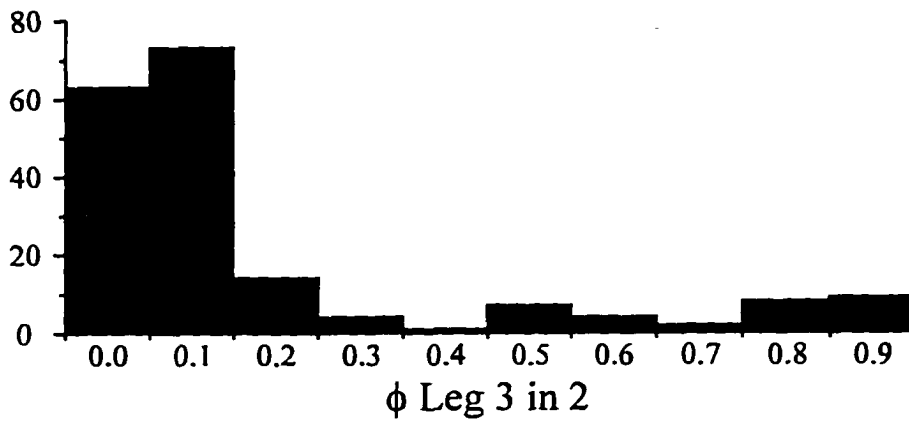
Coupling of legs 2 and 3 in *B. occidentalis*. (A) Phase histogram of forward movement of leg 3 relative to forward movement of leg 2. (Same data as Figure 2.8A.) (B) Phase histograms of leg 3 depressor onset relative to leg 2 depressor period, both left and right sides. (C) Phase/period plot of leg 3 depressor onset in leg 2 depressor period (showing if phase changes as animal speeds up or slows down). Same data as *B*. Sample sizes: B, C = six sequences from two animals.



(A)



(B)



(C)

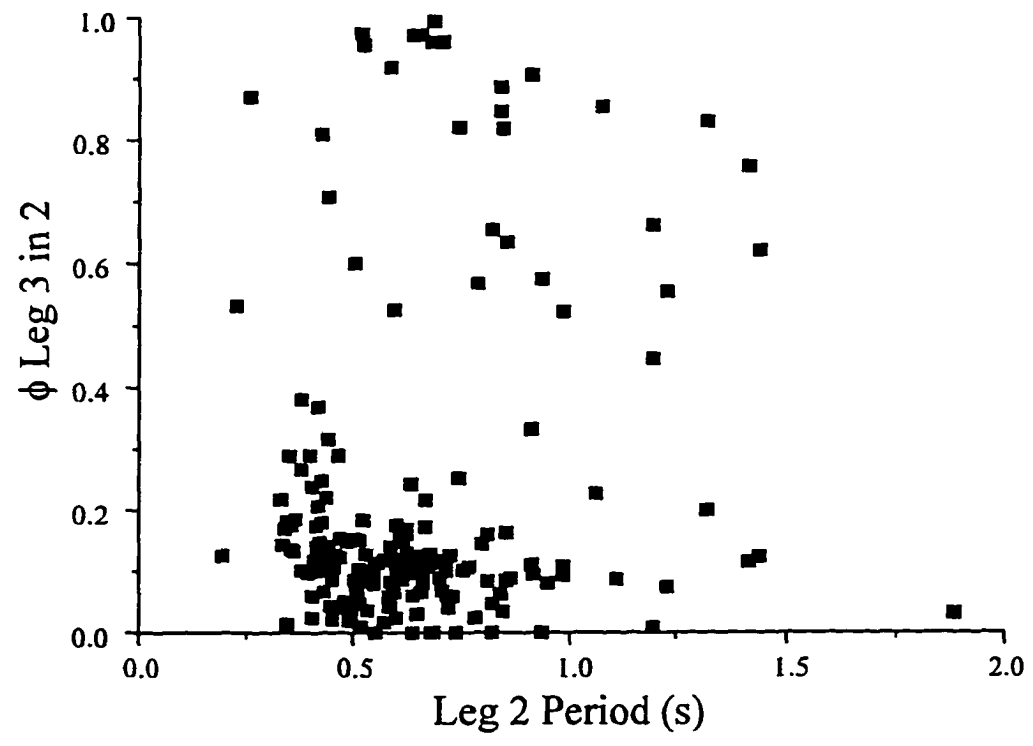
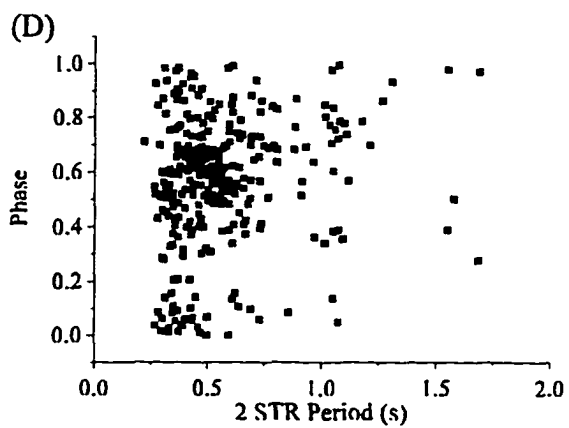
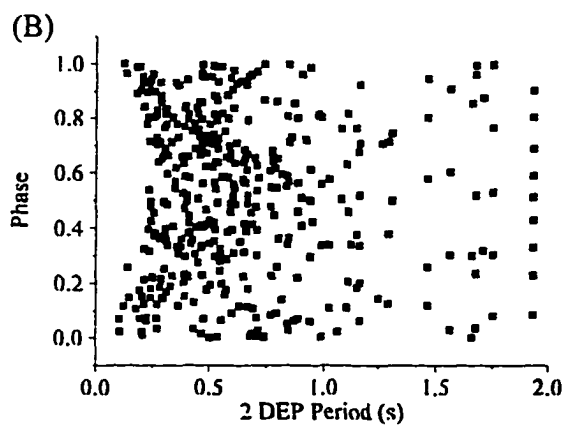
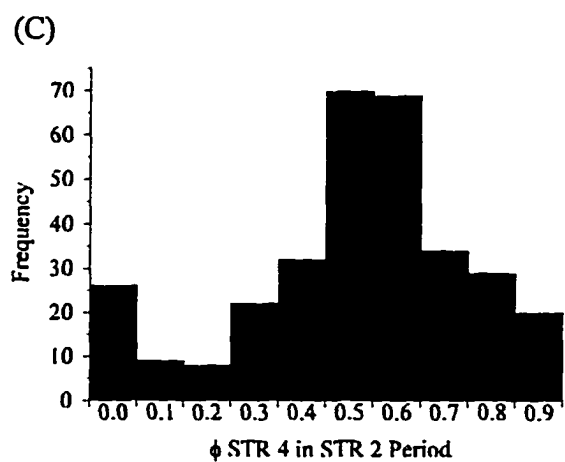
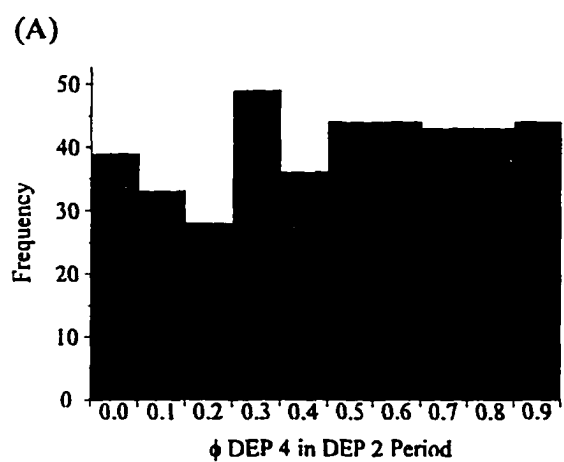


Figure 2.10: Coupling of legs 2 and 4 in *E. analoga*

Little to no coupling of legs 2 and 4 in *E. analoga*. (A) Phase histogram of leg L4 depressor in leg R2 depressor period. (B) Phase/period plot of leg L4 depressor in leg R2 depressor period. Same data as in A. (C) Phase histogram of leg L4 stretcher in R2 stretcher period. (D) Phase/period plot of leg L4 stretcher in R2 stretcher period. Same data as in C. A and B suggest no coupling between the pair of legs, whereas C and D suggest there might be; see text for possible explanations. Sample size: A-B = 19 digs from four animals; C-D = 25 digs from four animals.



Bilateral coordination

Sand crabs' bilateral legs usually alternate, as occurs in most other arthropods during walking [Cruse 1990; Jamon & Clarac 1995; Müller & Cruse 1991], except in some cases where there is a strong tendency for them to be synchronous.

Blepharipoda occidentalis and *Lepidopa californica*

The coordination of the bilateral legs is very similar in *B. occidentalis* and *L. californica* (Figure 2.11A-D, Figure 2.12, Figure 2.13, Figure 2.18A-D). When held in water and early in digging, the bilateral legs alternate (i.e., phase ≈ 0.5): when the left leg is moving forward, the right is moving backward. As an individual digs, legs 1 through 4 switch gait from bilateral alternation to synchrony (i.e., phase ≈ 0 or 1): the left and right legs move forward and backward together (Figure 2.12, Figure 2.13, Figure 2.18A-D). The gait switch usually occurs over a few cycles ($\sim 4-5$) but can be more abrupt ($\sim 1-2$ cycles). This gait switch is almost certainly triggered by the increased load of the sand on the legs, but it is not clear what biomechanical advantage there may be to switching gait or what sensory cue triggers it. The onset of the gait switch is also approximately when the claws begin making large, rhythmic movements which actively move sand.

I saw one *L. californica* making atypical leg movements: rhythmically moving legs 4 synchronously while legs 2 were moving alternately. I have never seen any suggestion of this pattern of *B. occidentalis*, even though I have observed *B. occidentalis* more.

Figure 2.11: Histograms of bilateral coordination in *B. occidentalis*, *L. californica* and *E. analoga*

Histograms showing frequency of occurrence of phases for left leg EMG onset relative to right leg EMG onset during digging. (A) Leg 2 opener and (B) leg 4 opener in *B. occidentalis*. (C) Leg 2 bender and (D) leg 4 stretcher in *L. californica*. (E) Leg 2 opener and (F) leg 4 stretcher in *E. analoga*. Although the distribution in *F* is similar to *A-D*, the near bilateral synchrony ($\phi \approx 0$ and 1) occurs at the end of digging in *B. occidentalis* and *L. californica*, but generally at the beginning of digging in leg 4 of *E. analoga* (Figure 2.12, Figure 2.13, Figure 2.18). Sample sizes: A = 17 digs from three animals, B = nine digs from one animal, C = four digs from one animal, D = seven digs from one animal, E = 20 digs from five animals, F = 23 digs from four animals.

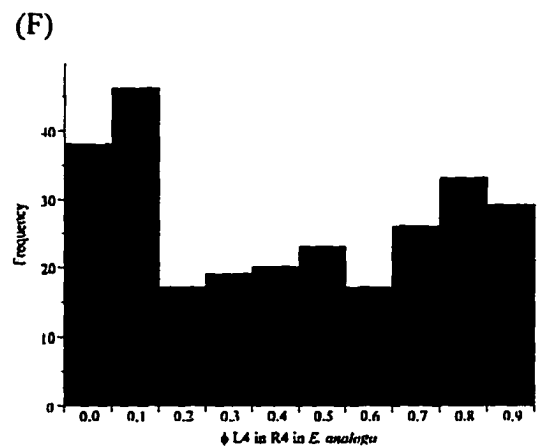
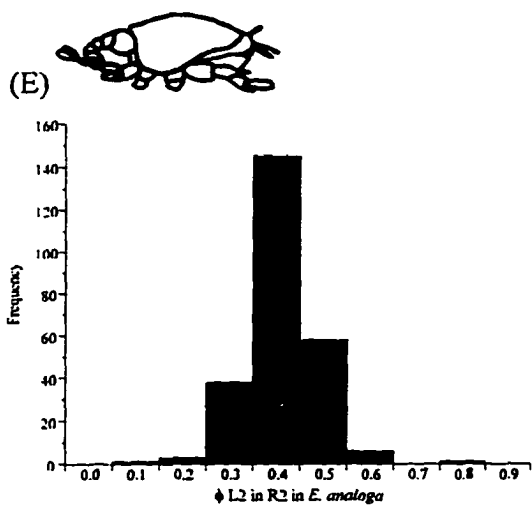
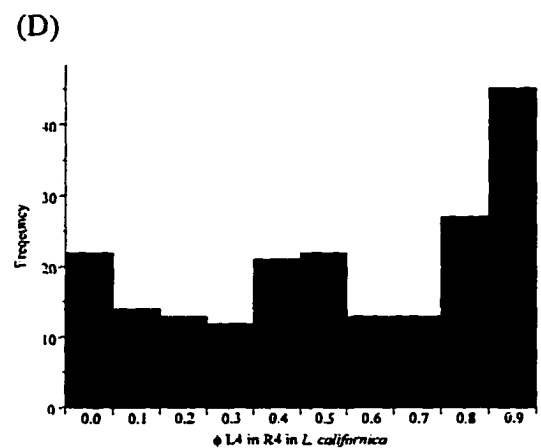
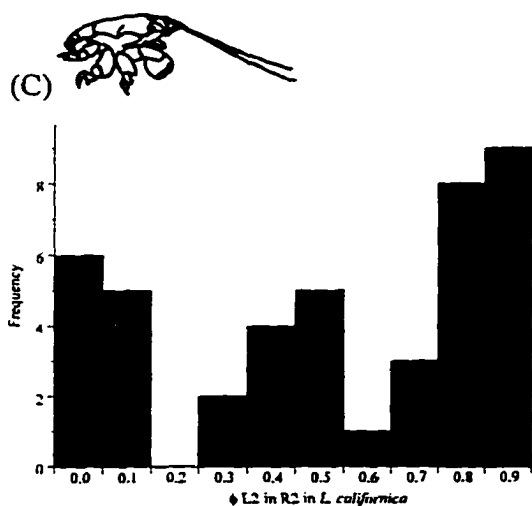
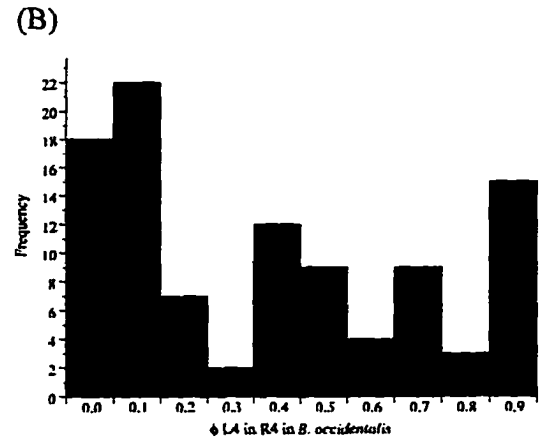
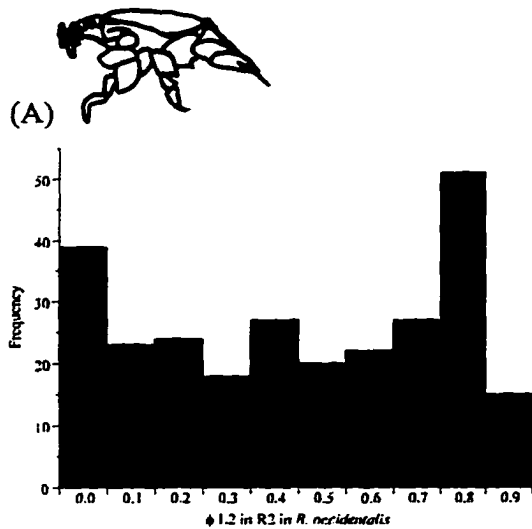


Figure 2.12: Gait switch in *B. occidentalis*

EMGs from opener muscles (OP) of legs R2 and L2 in *B. occidentalis*. The transition from bilateral alternation to synchrony is approximately at the fifth stroke of the legs. In this and subsequent EMG figures, vertical lines link concurrent EMGs; solid vertical lines show start and end of sequence; dashed vertical lines indicate EMGs of consecutive sets of traces.

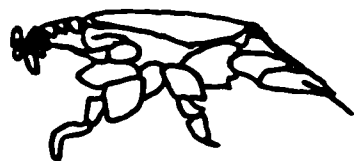
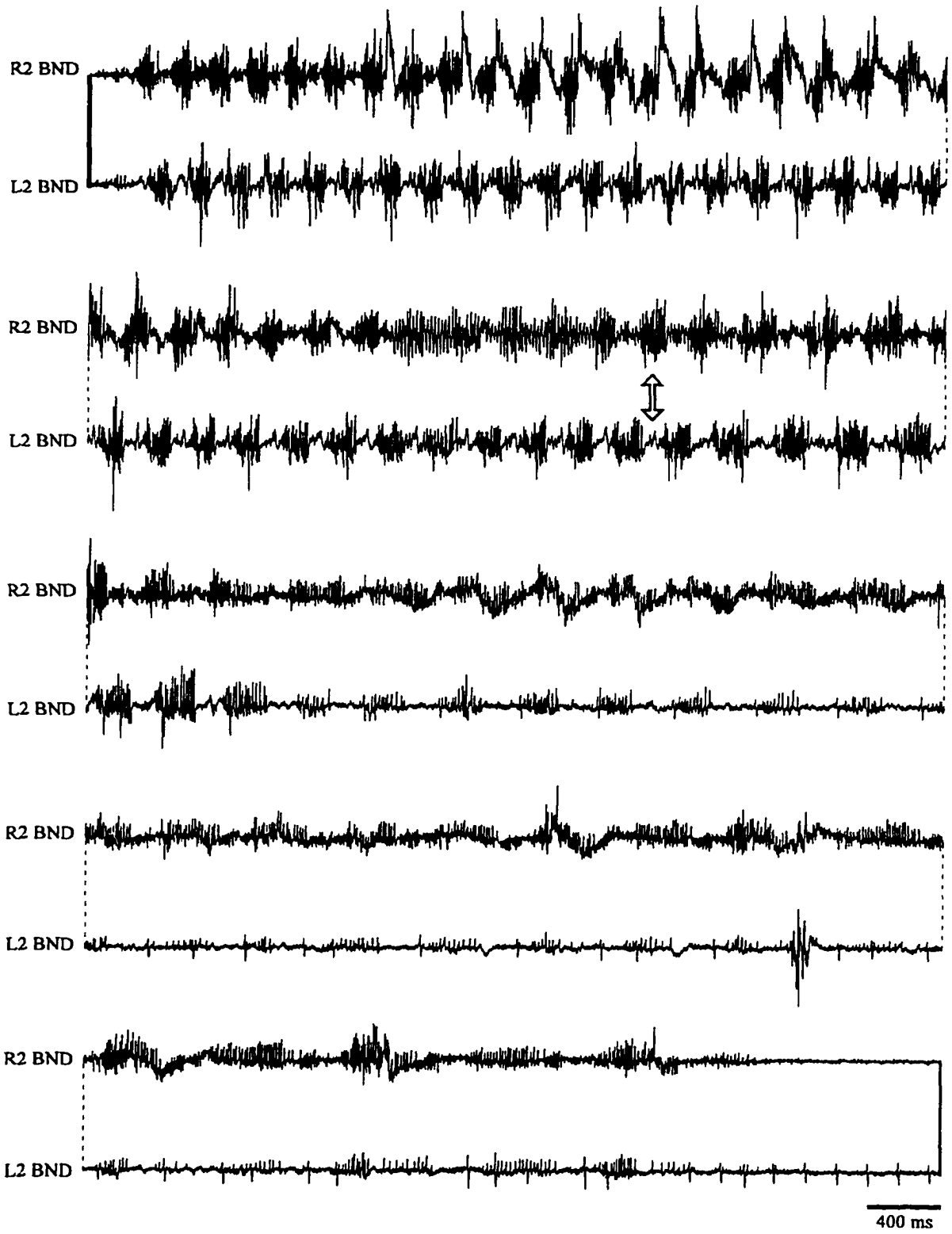


Figure 2.13: Gait switch in *L. californica*

EMGs from bender muscles (BND) of right and left legs 2 in *L. californica*. The animal was swimming above the sand at the start of record; approximate start of digging shown by double arrow between traces. Bilateral synchrony begins in the first part of the third pair of traces.



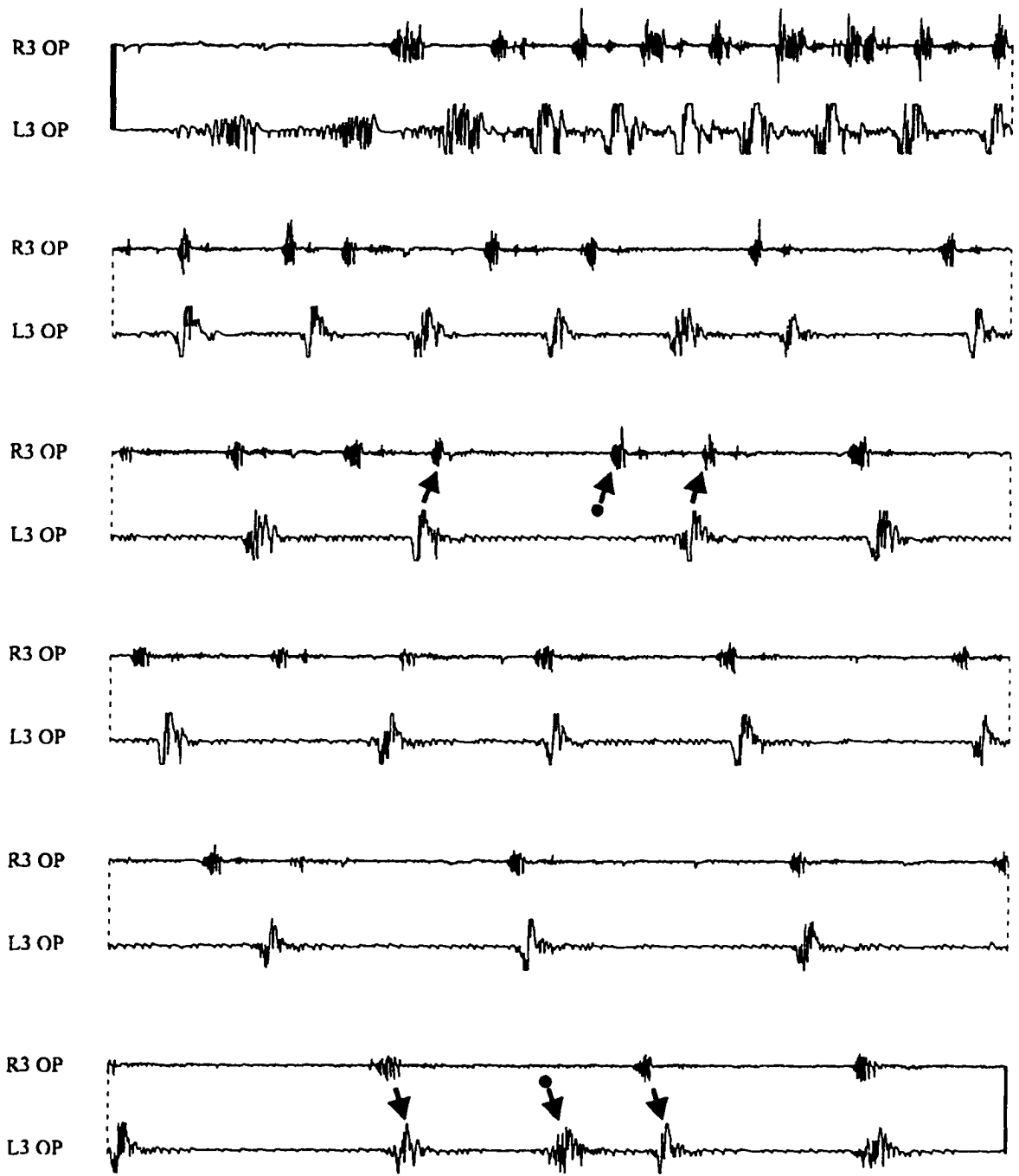
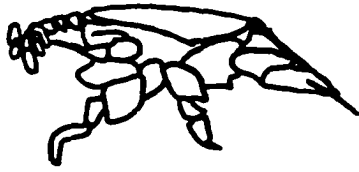
PERTURBATIONS IN BILATERAL COORDINATION CAUSED BY LEG LOSS

Although the gait switch is very typical of digging sequences in intact albuneids, it is not in animals with missing legs. The bilateral coordination between the remaining pairs of legs became much more variable in *B. occidentalis* with missing legs (not lesioned by the experimenter). Although the gait switch could still occur, the phasing of bilateral legs tended to drift far more than in intact animals. One individual missing its right leg 4 did not gait switch at all (Figure 2.14B).

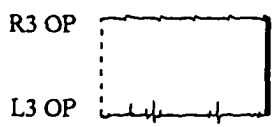
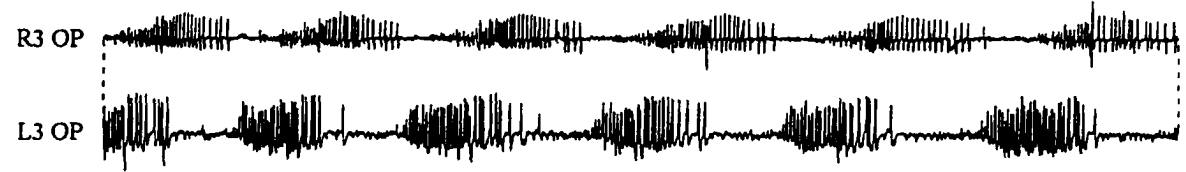
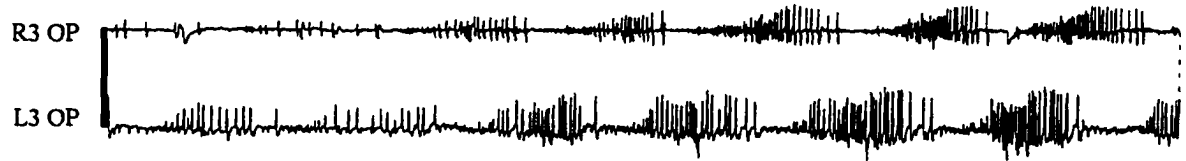
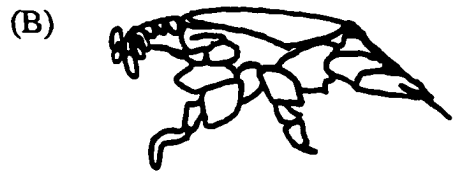
Figure 2.14: Perturbations in gait switch in *B. occidentalis*

(A) Absence of one leg 2 affected bilateral coordination in *B. occidentalis*. Opener EMGs from legs L3 and R3 in a *B. occidentalis* missing R2. This animal switched from bilateral alternation to synchrony, but the coupling was far looser than normal (compare with Figure 2.12), and each occasionally generated two short period EMGs bursts when the contralateral leg generated only one (bulleted arrows indicate “extra” EMG burst). (B) Loss of one leg 4 affected bilateral coordination in the remaining pairs of legs. Opener EMGs from legs R3 and L3 in *B. occidentalis* missing R4. This digging sequence shows no evidence for the typical albuneid gait switch from bilateral alternation to synchrony (e.g., Figure 2.12, Figure 2.13), although other digs by the same animal showed that it could switch from bilateral alternation to synchrony.

(A)



500 ms



500 ms

Emerita analoga

The coordination of the bilateral legs in *E. analoga* is more complicated than in the albuneids. Video and EMGs show that legs 2 and 3 always alternate: they do not switch gait during digging as they do in the two albuneid species (Figure 2.11E, Figure 2.15). I also never saw any indication of leg 1 moving in bilateral synchrony during digging.

In contrast, EMGs show that legs 4 often move in bilateral synchrony during digging (Figure 2.11F); this was also occasionally videotaped in animals suspended in water. Unlike the albuneids, the bilateral synchrony of legs 4 normally occurs at the start of a digging sequence rather than at the end (Figure 2.16, Figure 2.17). As *E. analoga* digs and the period of legs 4 increases, the bilateral coordination of legs 4 becomes more variable and then the frequency approximates that of the uropods. The coordination between the legs and uropods is examined in more detail in Chapter 4.

Figure 2.15: Bilateral coordination of legs 2 and 3 in *E. analoga*

Right and left legs 2 in *E. analoga* always alternate. EMGs from opener muscles in leg R2 and L2. This record shows one complete digging sequence.

250 ms

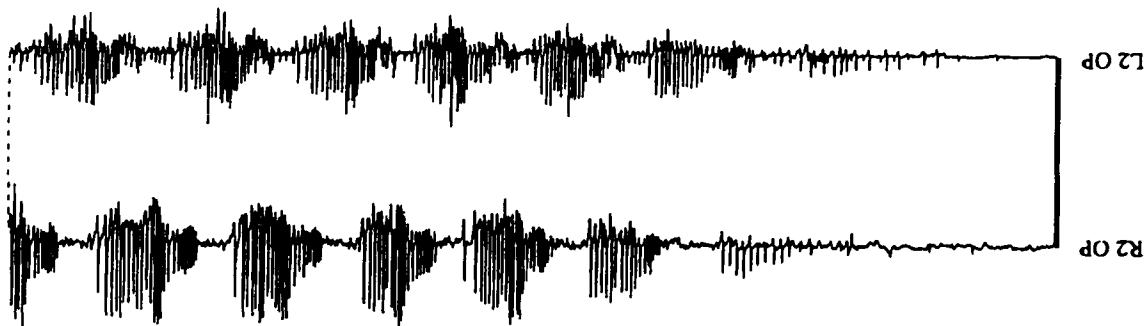
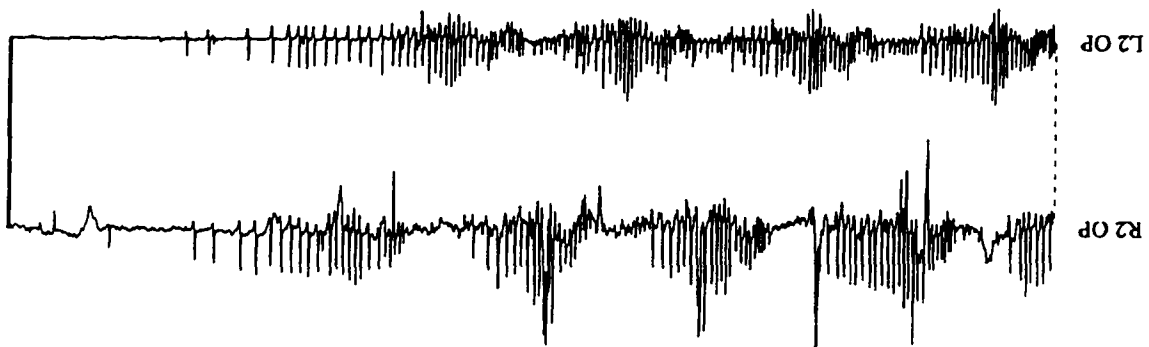
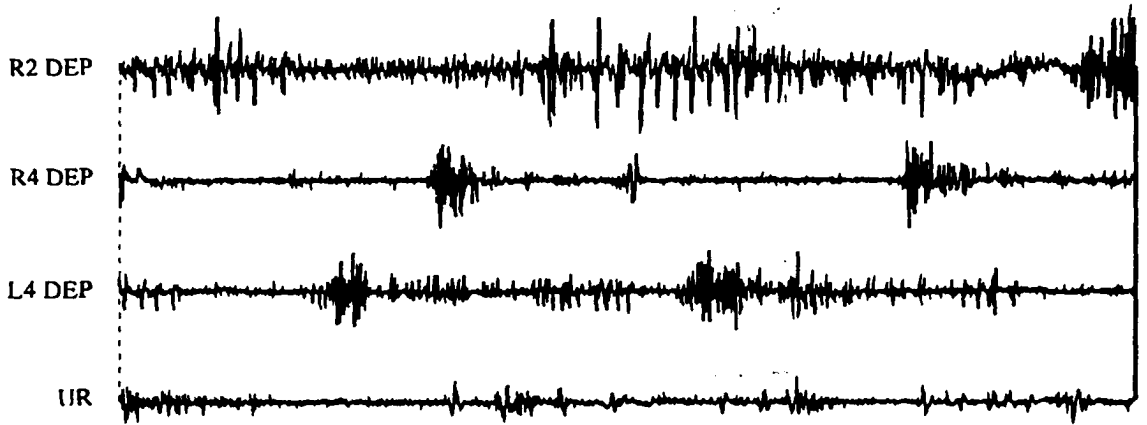
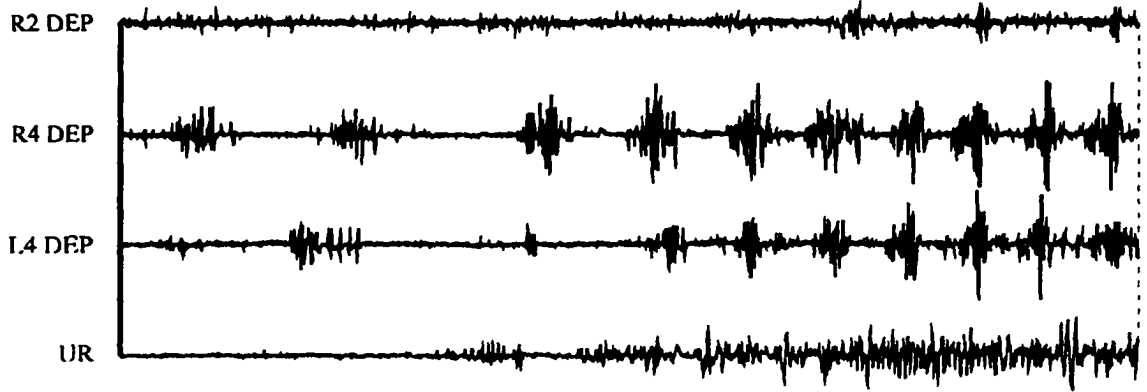


Figure 2.16: Bilateral coordination of legs 4 in *E. analoga*

Right and left legs 4 in *E. analoga* move either in synchrony or in alternation. EMGs from (top to bottom) depressor muscles in leg R2, leg R4, leg L4, and from uropod muscles in telson. R = right; L = left; DEP = EMGs from leg depressor muscle; UR = EMG from uropod muscles.



250 ms

Figure 2.17: Coupling of bilateral legs 4 in *E. analoga*

Legs 4 of *E. analoga* are synchronous during fast movements. (A) Phase histogram of leg L4 depressor in leg R4 depressor period. (B) Phase/period plot of leg L4 depressor in leg R4 depressor period. Phase is random at periods greater than ~ 0.3 s. Same data for *A* and *B*; different data than Figure 2.11*F*. Sample size = 19 digs from four animals.

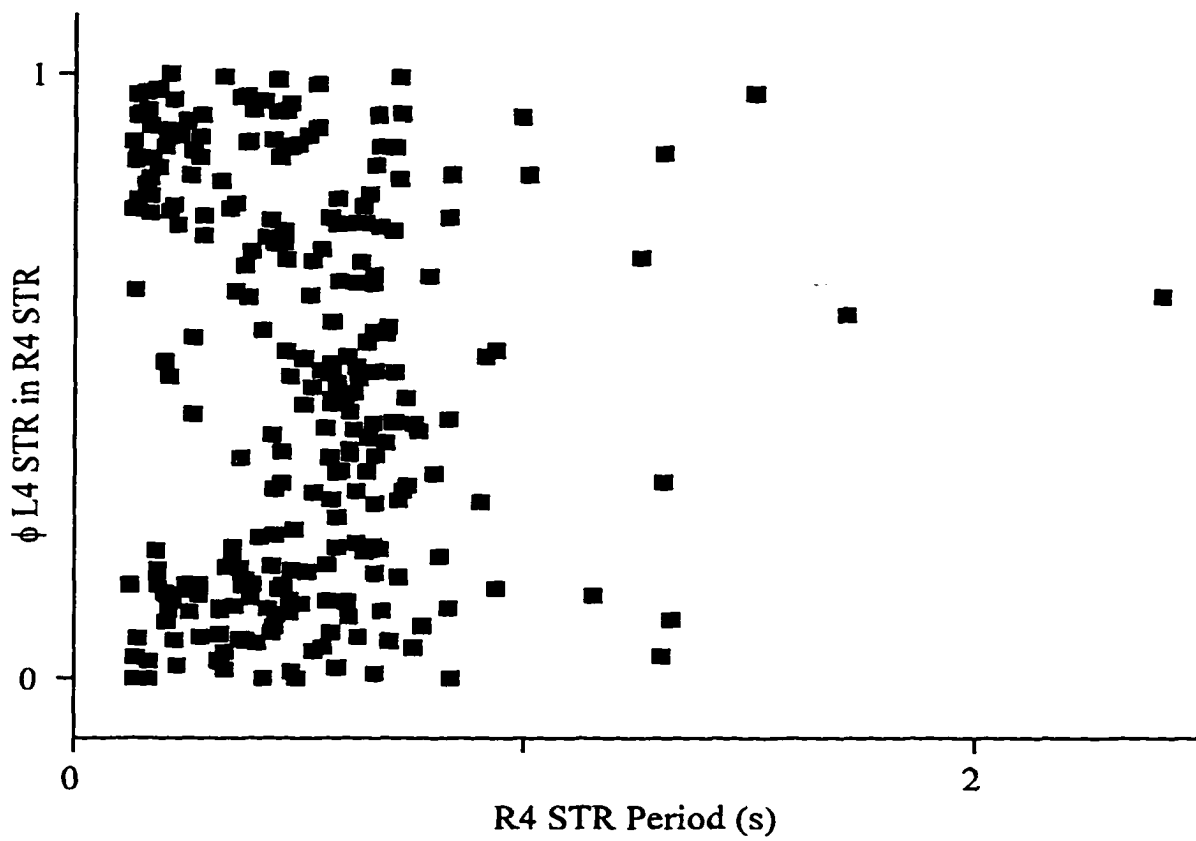
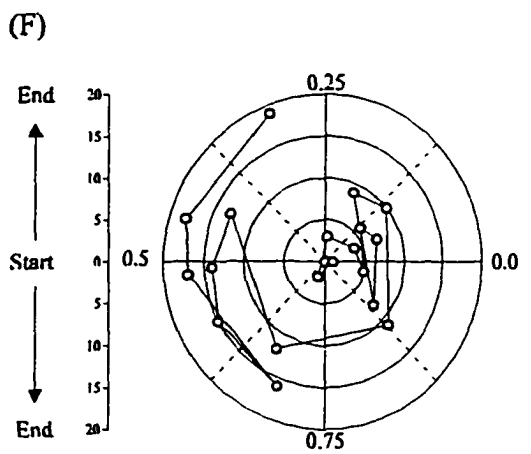
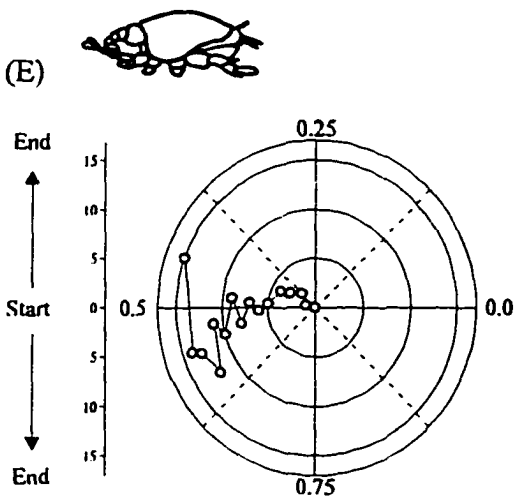
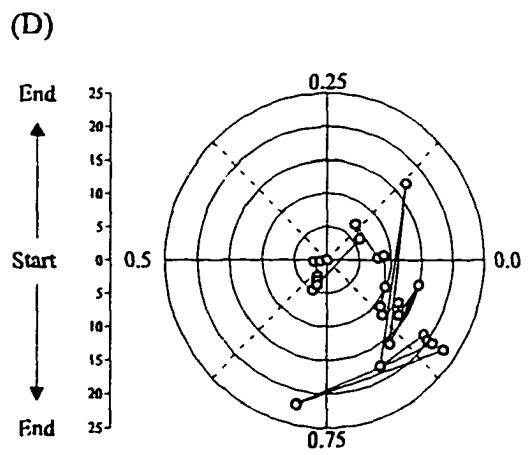
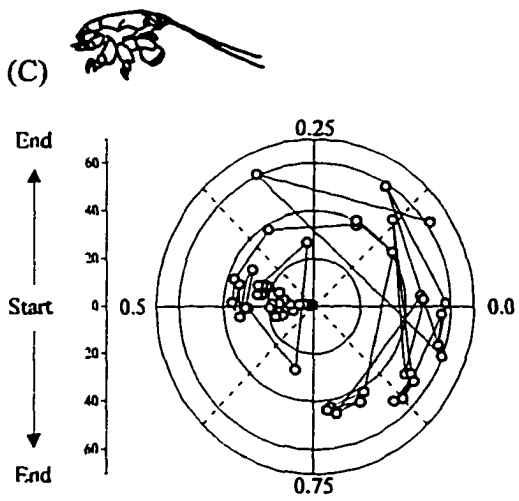
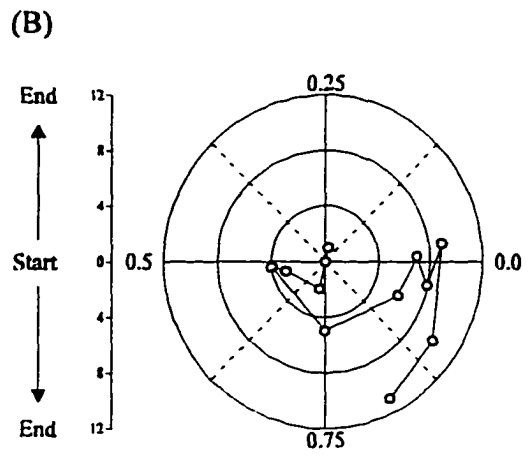
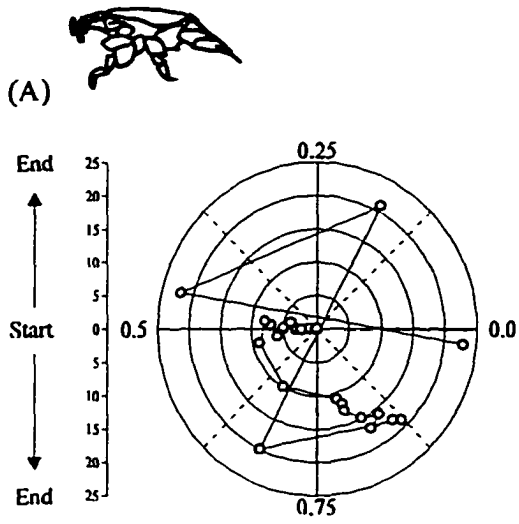


Figure 2.18: Circular plots of bilateral coordination in *B. occidentalis*, *L. californica*, and *E. analoga*

Circular phase plots of individual digs. Sequence begins at center of circle and continues outward; phase plotted around edge of circle. (A) Leg L2 opener in R2 opener period and (B) leg L4 opener in R4 opener period in *B. occidentalis*. (C) Leg L2 bender in R2 bender period and (D) leg L4 stretcher in R4 stretcher period in *L. californica*. (E) Leg L2 opener in R2 opener period and (F) leg L4 stretcher in R4 stretcher period in *E. analoga*.



Discussion

Legs 2 and 3 appear to provide most of the propulsive force during digging, while the movements of leg 4 are less powerful but important in allowing an animal to descend rapidly into sand. The variable movement of leg 4 and its loose coupling with the more anterior legs compared to the coupling between legs 2 and 3 suggest that sand crab digging legs have separate command systems.

Homology and divergence in sand crab digging

The similarities between the digging patterns of three species of the two families (*Blepharipoda occidentalis*, *Lepidopa californica*, and *Emerita analoga*) provide evidence that digging is a monophyletic, derived character shared among members of the sand crab superfamily (see also Chapter 3). (1) The tip trajectories are similar in all three, with legs 2 and 3 circling in the opposite direction of leg 4. (2) The movements of legs 2 and 3 are tightly coupled, with leg 2 leading leg 3 in all three species. (3) The movements of leg 4 are quite variable and loosely coupled with those of legs 2 and 3. (4) Legs 2 and 3 move in bilateral alternation when animals are held in water.

Although the evidence clearly supports a monophyletic origin for sand crab digging, digging has diverged within the sand crab superfamily. The albuneid species, *B. occidentalis* and *L. californica*, switch gait from bilateral alternation to synchrony as they dig. The fact that this gait switch is exhibited by two species of different sizes and belonging to genera which do not appear to be closely related [Efford 1969] suggests that the trait is common to all albuneids and not a function of size. The function of the switch is not clear, but one reason why *Emerita* (and presumably other hippids) do not switch gait may be because their first pair of legs is very long. In *Emerita*, leg 1 is rudder-shaped and aids steering during uropod beating [Paul 1981a]. The same legs are equally or slightly longer in the genus *Hippa*, and remarkably long in *Mastigochirus*, where the dactyl is multi-segmented [~20 articulations; Snodgrass 1952; Haig 1974]. These legs would collide with each other if hippids moved all their bilateral legs in synchrony like

albuneids. The second distinction between the albuneids and *Emerita analoga* is the coordination of leg 4. Probably by virtue of being more tightly coupled to movements of the uropods (see Chapter 4, Coordination of the legs and “tail”: 173), leg 4 in *E. analoga* is able to (1) cycle at higher frequencies than legs 2 and 3, and (2) move in bilateral synchrony even though legs 2 and 3 always move in bilateral alternation.

Evolutionary origins for digging

The evidence strongly suggests that digging is a monophyletic feature in sand crabs, but it is less obvious how digging originated. One possibility is that digging is an entirely new behaviour with no important relationship to behaviours in non-digging crustaceans. I call this the “Athena hypothesis” (in Greek mythology, Athena sprang from Zeus’s forehead, complete and fully formed). The similarity of leg motor neurons in digging and some walking species (see Chapter 6: 196; Figure 6.2), however, make the “Athena hypothesis” unlikely. Nevertheless, the distal leg motor neurons form only a small part of the circuitry controlling the thoracic legs, so if the anatomy and physiology of the many other neurons in the digging pattern generators are different than those in walking species, the “Athena hypothesis” would be viable.

A complex biological feature like digging is unlikely to have evolved *de novo*, so some antecedent behaviour should have been present in a non-digging sand crab ancestor. Candidate rhythmic behaviours involving the legs in other decapods include waving [Pasztor & Clarac 1983], swimming [Hartnoll 1970; Spirito 1972], and walking [reviewed in Evoy & Ayers 1982; Clarac 1984].

Waving is an unlikely homologue to digging for several reasons. First, waving occurs when legs are unloaded, whereas the legs are very definitely loaded during digging. Second, the forward and backward leg movement seen during waving is strictly metachronal along one side, whereas digging in *B. occidentalis* and *L. californica* is more like an alternating tripod gait. Third, only the thorax-coxa joint is moved during waving, whereas all joints are moved during digging. Fourth, waving is slow and digging is not.

A few brachyuran crabs can swim with their thoracic legs [Hartnoll 1970; Spirito 1972] and *B. occidentalis* [Paul 1981a] and *L. californica* also swim using their legs. It might be argued that digging evolved from swimming, but most adult decapods swim by swimmeret beating or tailflipping [Hessler 1985]. Although the ability for sustained swimming has evolved repeatedly in crustaceans [Hessler 1985], no other anomurans besides albuneid sand crabs are known to swim using their legs. Given this, a fairly complicated chain of events would be required to posit the evolution of digging from swimming, namely: that swimming evolved from some pre-existing behaviour, and that the swimmers later became diggers, but somehow these intermediate swimming anomurans were lost, leaving neither fossils [although the anomuran fossil record is admittedly fragmentary; Glaessner 1969] nor representatives among the extant anomurans. It is parsimonious to assume that the use of the legs in albuneid swimming is a secondary adaptation derived from digging, and not the reverse.

Digging is most likely to have evolved from walking. This simple statement is more complicated than it first appears. Sand crabs only dig backwards, but walking comes in several varieties: decapods use different motor patterns of interjoint coordination to walk in different directions [Ayers & Clarac 1978]. Digging is unlikely to have evolved from sideways walking because the body and the legs move in the anterior/posterior plane during digging. Backward walking is the obvious candidate to be homologous to digging simply because the body is displaced backwards in both behaviours. This hypothesis will be examined further in Chapter 3.

Central control

In crayfish, stimulating one of a small number of "command system neurons" [formerly "command neurons;" Larimer 1976, 1988] in the circumesophageal connective can elicit relatively complex behaviour involving the entire body, including forward and backward walking [Bowerman & Larimer 1974; Larimer 1976]. Although their anatomy is not known, these command system neurons probably descend from the brain and have output to each of the thoracic hemiganglia controlling the legs, where they may synapse

on local interneurons which initiate rhythmic activity in a single hemiganglion [e.g., Pearlstein et al. 1995]. It is highly probable that sand crabs have similar neurons, although given how uniform digging is compared to walking, there may be fewer of them, or they may be more uniform in their physiological effect. The tight coupling of legs 2 and 3 suggests that their movement may be initiated by a small number of command system neurons (possibly only one) which turns on the hemiganglionic pattern generators for legs 2 and 3. Leg 4, however, often stays still while legs 2 and 3 are moving; this suggests that its motor pattern is initiated by a separate command system, the activity of which is more dependent on sensory input and the activity of legs 2 and 3. (See summary diagram; Figure 7.1.)

Sensory input

During walking, sensory inputs from the proximal joints [Sillar et al. 1986, 1987] and the tip of the leg [Klärner & Barnes 1986; Jamon & Clarac 1995; Müller & Clarac 1990a, b] are important cues mediating the timing of stepping. Because sand crabs' legs move through a substrate, however, it seems unlikely that sensory input from the leg tip is used as a sensory cue to mediate the precise timing of digging leg movements, since there is no moment when dactyl afferents would receive a distinct, phasic signal. It is more probable that any tactile input from the many leg hairs (from which *Blepharipoda* derives its name) act as a "primer," facilitating activity in the nervous system generally. In *E. analoga*, electrical stimulation of the distal leg nerve *in vitro* augments tonic activity in the terminal abdomen ganglion for relatively long times (i.e., minutes) [D.H. Paul, personal communication].

Sensory input could be important in coordinating aspects of digging leg movements, such as the transition from power to return stroke in leg 2 [similar cases reviewed in Pearson 1993]. In leg 2, a possible homologue to the crayfish thoracic-coxal chordatonal organ [Skorupski et al. 1992] is an especially good candidate, because it responds to leg promotion, which is the movement component in which the sand crab leg experiences the most drag. During "fictive walking," the thoracic-coxal chordatonal organ

in crayfish mediates an assistance reflex in promotor motor neurons [Skorupski et al. 1992].

The much greater variability of the movements of leg 4 in all three sand crab species suggests that the movement of leg 4 is more heavily dependent on sensory feedback than legs 2 and 3 are. It is unclear what the relevant sensory input for leg 4 may be because the power and return stroke components in leg 4's movements are not clear (see also Chapter 3, EMG burst and period: 130). Questions include what the relative strengths of tactile and proprioceptive input might be, and which of the several proprioceptors the leg might have are most likely to influence the digging motor pattern.

The gait switch of *B. occidentalis* and *L. californica* may be triggered by load on the legs, since these species normally do not move their legs in bilateral synchrony when held in water or at the start of a digging sequence. Rapid phase transitions similar to the albuneid gait switch have been observed in other situations [e.g., tetrapod gaits, Alexander 1989; human finger movements, Kelso 1984; Kelso & Scholz 1985; spiders switching from walking to swimming, Barnes & Barth 1991]. In many cases, these occur as movement frequency increases, unlike the albuneid gait switch, which occurs as frequency decreases. Nevertheless, considering the load on the leg, the motor output of the legs should be more strongly activated ("effort" may be an anthropomorphic equivalent) despite the slower speed than when they are above sand. In palinurans, however, an increased load on the legs (by adding weight on an animal's back) makes legs less likely to move in bilateral synchrony, not more [Clarac & Barnes 1985]. These different results may be due to the fact that load of sand on sand crabs' legs, particularly legs 2 and 3, impedes promotion at the thorax-coxa joint. Load on the back of a palinuran, however, will make depression of the coxa-basis joint (to lift the body) more difficult. A better "crayfish-like" analogue to the sand crab situation would be to increase the resistance on a treadmill which a crayfish was walking backwards on. To my knowledge, that experiment has not been done in any studies of decapods walking on treadmills [e.g., Barnes 1977; Chasserat & Clarac 1983; Clarac 1984; Clarac & Barnes 1985; Clarac & Chasserat 1983].

Chapter 3: Interjoint coordination¹

A living crayfish is able to perform many varied movements with its pincers. ... Nevertheless, these very varied actions are all brought about by a combination of simple flexions and extensions, each of which is effected in the exact order, and to the exact extent, needed to bring the chela into the position required. ... It would probably puzzle a good mathematician to say exactly what position should be given to each segment, in order to bring the chela from any given position into any other; but if a lively crayfish is incautiously seized, the experimenter will find, to his cost, that the animal solves the problem both rapidly and accurately.

[Huxley 1880: 95-96]

Introduction

The study of interjoint coordination within a single limb has received much less attention than interleg coordination. Most of the studies on interjoint coordination have focused on reflexes which affect several joints in a limb segment [e.g., Cattaert et al. 1993; El Manira et al. 1991a, b; Müller & Clarac 1990a]. There has been less work, both empirical and theoretical, on the central mechanisms of interjoint coordination. One proposal is that each joint in a limb may be controlled by a separate “unit central pattern generator,” a group of neurons, comprising a subset of a limb pattern generator, which tend to generate oscillating motor output to the antagonistic muscles of a single joint [Grillner 1985; Stein 1985]. In theory, the relationships between these unit central pattern generators could be reconfigured to generate the full range of normal motor output [Bässler 1993; Grillner 1985; Stein 1985]. While many data are consistent with this hypothesis, there have been few direct tests of it [but see Büschges et al. 1994]. Many of the animals (or the portions thereof) used for the study of pattern generation lack limbs [e.g., swimming by lamprey, Grillner et al. 1995; swimming by frog tadpoles, Roberts 1990; Arshavsky et al. 1993; swimming by the mollusc *Clione*, Arshavsky et al. 1993;

¹ Abstracts based on material in this chapter have been published [Faulkes & Paul 1993, 1995].

crustacean stomatogastric system, Harris-Warrick et al. 1992], or have unjointed limbs [e.g., locust flight, Reichert 1985]. Jointed limbs are sometimes treated as struts making simple forward and backward movements (i.e., power and return strokes), with little emphasis on the timing of events within those gross movements [e.g., crustacean swimmeret, Davis 1973; crustacean walking, Clarac 1984; insect leg movements, Cruse 1980a]. In vertebrates, the complexity of interjoint coordination is appreciated [Ganor & Golani 1980; Stein 1985], but the neural circuitry underlying coordination of single limbs is still not well enough understood to understand its mechanisms [but see Cazalets 1995; Cazalets et al. 1995]. In invertebrates, interjoint coordination has been most closely examined in stick insects [e.g., Bässler 1993], but these insects face particular locomotor problems by virtue of being tree-climbing animals: the “terrain” they must navigate is uneven and missteps could cause costly falls. Further, stick insects’ main means of avoiding predation is twig mimesis: this tactic depends on moving slowly, and several features of stick insect joint control function to help ensure slow movements [Bässler 1993]. It is an open question as to how general the findings about interjoint coordination gleaned from stick insects will be.

Sand crabs may be excellent subjects to examine mechanisms of interjoint coordination. In this chapter, I will show that the legs of digging sand crabs have a complex pattern of interjoint coordination (Figure 3.4) which is not the same in all the digging legs (Figure 3.4 to Figure 3.7). The pattern of interjoint coordination is similar in different species and changes only slightly under different conditions (i.e., making leg movements above sand compared to digging in sand; Figure 3.8 to Figure 3.14; Figure 3.23 to Figure 3.26), suggesting that the mechanisms of interjoint coordination is robust. The interjoint coordination of the legs in sand crabs also provides evidence on the hypothesised homology between digging and walking (Figure 3.16 to Figure 3.21).

Methods

Animals were collected as described in the previous chapter (Chapter 2, Methods: 18). Leg musculature was examined following gross dissection. Joint angles were measured by flexing leg segments in live or freshly dissected animals.

Video and EMG recordings of *B. occidentalis* were made simultaneously using the techniques described in the previous chapter (Chapter 2, Interleg coordination, Methods: 18). The two records were synchronised using a device that stripped a 30 Hz signal from the video camera which was synchronised with the camera's electronic shutter; a manually activated event marker turned on an LED light visible in the video and superimposed a 1 kHz wave on top of the signal taken from the video camera (Appendix C, Video synchronisation: 269). The combined signal from the camera and event marker was recorded on FM tape alongside the EMGs. I aligned the event markers during analysis.

The temporal relationships between pairs of events are described using words coined by Golani [1976]. The definitions of the terms are shown in Figure 3.1.

Omissions and limitations

The movements of leg 1 were not analysed because they do not make full amplitude movements when animals are above sand and they appear to contribute to sand crabs' digging ability less than the more posterior legs do. In *E. analoga*, the movements of leg 1 are even smaller than they are in *B. occidentalis*.

The interjoint coordination of legs in *E. analoga* could not be examined using video analysis for several reasons: individuals tend not to make leg movements when held in water, the telson conceals the proximal leg joints while the carapace obscures some of the more distal joints, and the spatial and temporal resolution of video were inadequate to resolve the movements of individual joints. Therefore, the interjoint coordination of *E. analoga* was examined using EMGs. What poses problems for video recording, however, can also pose problems to EMG recording. The small size of *E. analoga*, particularly of leg 4, made it difficult to place electrodes within a given muscle accurately and without cross-talk. In leg 4, some muscles (notably the extensor and flexor) could not be recorded

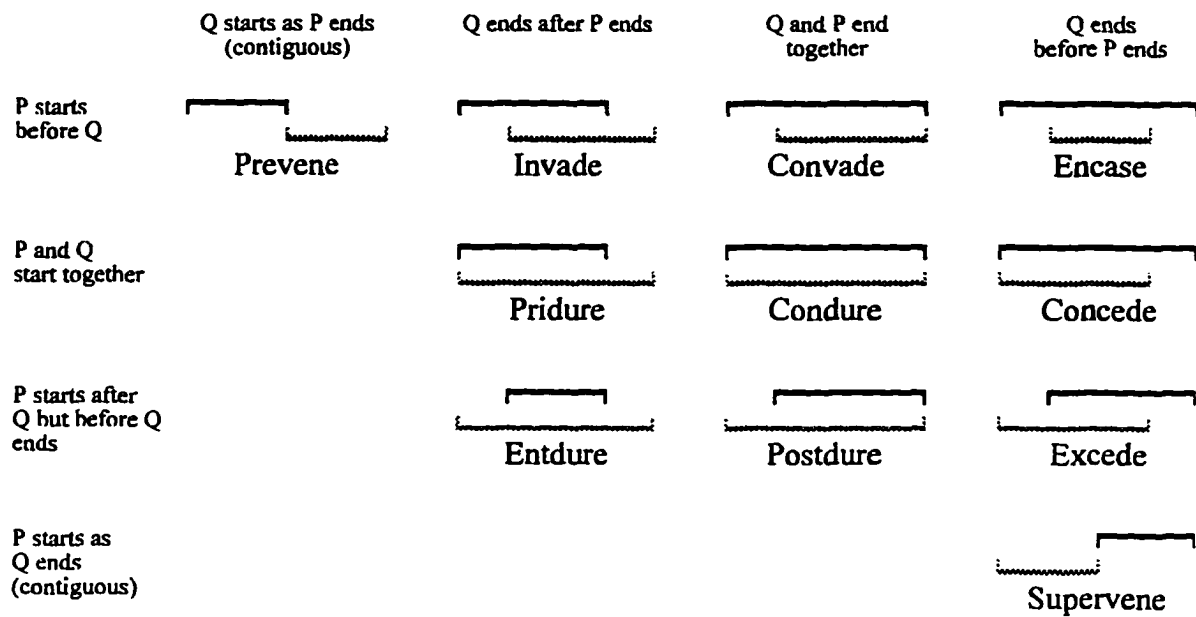
from because the carapace covers some of the leg segments. Although the EMG saddle attached to the carapace of *E. analoga* was made as small as possible, it still had a proportionately greater mass relative to *E. analoga* than to *B. occidentalis*, so EMG recordings are more intrusive and more likely to affect normal motor patterns in *E. analoga* than *B. occidentalis*. Therefore, my confidence level in the EMGs from *E. analoga* is lower than for EMGs from *B. occidentalis*.

The interjoint coordination of *Lepidopa californica* was not be examined. Too few animals were available to examine interjoint coordination using EMG recordings, and all the problems encountered of video recording with *E. analoga* applied even more so with *L. californica*.

In some previous studies, researchers were able to identify the firing of particular motor neurons by the different EMG potentials they generated [e.g., Ayers & Clarac 1978]. Unfortunately, it was very difficult to interpret individual potentials in this research. The EMG waveforms recorded from digging sand crabs are often very complex: EMG potentials tend to be high frequency, so that much variation in potential amplitude could be due to facilitation and/or summation. In most animals, electrodes were re-implanted in different muscles to reduce the very large number of animals that otherwise would have been needed; therefore, it was not practical to confirm the placement of electrodes by post-recording dissection.

Figure 3.1: Temporal relationships

Words describing temporal relationships [proposed by Golani 1976]. *P* and *Q* can stand for any pair of events; *P* is the subject of the sentence and *Q* is the object. Therefore, “elevation invades remotion” is logically identical to “remotion exceeds elevation.”



Results

Sand crab leg morphology

Like most reptantian decapods, sand crabs' legs (Figure 3.2) have six hinge joints that generally do not allow rotation [Hessler 1982; Lochhead 1961], although the carpus-propus joint, with only one tightly articulated condyle, allows some rotation [Hessler 1982; Table 3.1]. The axes of adjacent joints tend to be nearly at right angles to each other in walking species [Lochhead 1961] and sand crabs.

Each segment is moved by antagonistic muscles located in the adjacent proximal segment. The muscles controlling the two most proximal joints are complex [Hessler 1982; Macmillan 1975; Bévengut et al. 1983], but function much like a simple pair of antagonists because of the hinged joints. The coxa is moved by groups of promotor (PRO) and remotor (REM) muscles located within the thorax, and the basi-ishium is controlled by levator (LEV) and depressor (DEP) muscles within the thorax and the coxa. The merus is slightly extended by the unpaired reductor (RED) muscle in the basi-ishium. There are three muscles moving the carpus: the extensor (EXT), the flexor (FLX), and the accessory flexor (aFLX). The propus is moved by the stretcher (STR) and bender (BND) muscles, and the dactyl is moved by the opener (OP) and closer (CL) muscles.

The endophragmal skeleton of sand crabs is heavier and more extensive than in many other decapods [Schram 1986; personal observations], providing a larger surface for the attachment of those proximal leg muscles that originate inside the thorax. Sand crabs legs are also more robust, and have enlarged, flattened dactyls on legs 2, 3 and 4. In walking species, the merus tends to be the largest limb segments, but in sand crabs, the carpus tends to be the largest leg segment in legs 2 and 3. This may be because the extensor and flexor are important in sideways locomotion, which sand crabs do not perform. Similarly, the range of the merus-carpus joint is smaller in sand crabs than most other walking species (Table 3.1).

Figure 3.2: Leg morphologies

Comparison of (A) leg 2 of a squat lobster, *Munida quadrispina*, a “typical” walking leg, (B) anterior view of left leg 2 of *B. occidentalis*, and (C) anterior view of left leg 2 of *E. analoga*. Other than shape, some of the main differences between them are that the sand crabs have a more flexible carpus-propus joint, a smaller range of movement allowed at the merus-carpus joint, and a larger range allowed by the propus-dactyl joint than in walking species. The *basi-ischium* is a fusion of two segments that are separate in other decapods, the basis and ischium. Setae omitted. Legs not to scale.

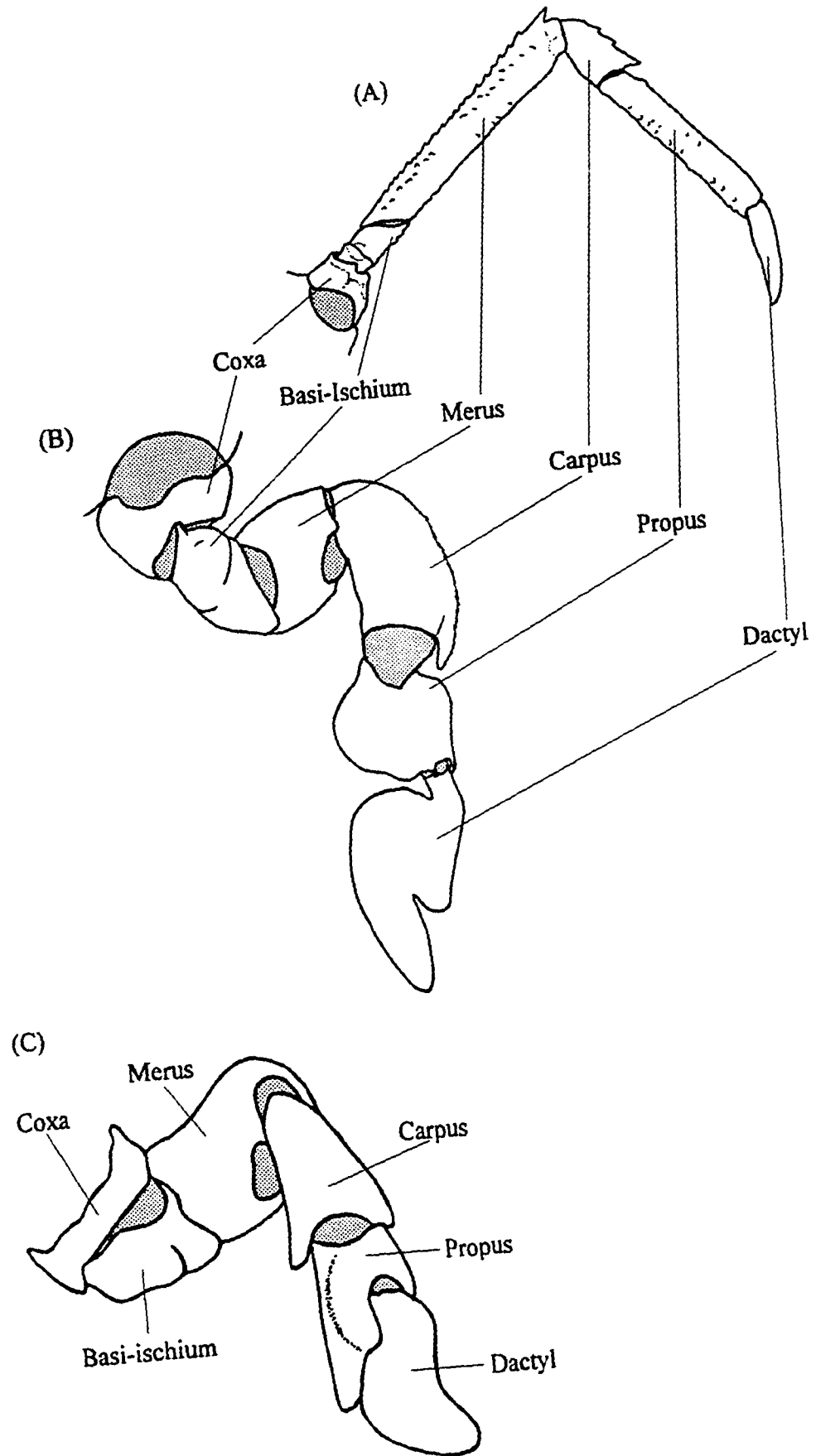


Table 3.1: Ranges of joint movement in some walking species and *B. occidentalis*

Data for brachyuran crabs omitted because of their specialisation for sideways walking [e.g., Clarac 1977; Sleinis & Silvey 1980]. Leg 3 is similar to leg 2 in *B. occidentalis*. The coxa-thorax articulation of leg 4 in *B. occidentalis* is not perpendicular to the thorax, so remotion also causes the leg to be lifted relative to the carapace.

Table 3.1

Joint	Walking Legs	<i>B. occidentalis</i> Leg 1 (Claw)	<i>B. occidentalis</i> Leg 2	<i>B. occidentalis</i> Leg 4
Thorax-Coxa	90° ¹ 135° ³ 74° ⁴ 100° ⁵	35°	50°	35°
Coxa-Basis	45° ¹ 95° ³ 110° ⁴ 90° ⁵	95°	70°	50°
Basis-Ischium	15° ³ 10° ⁴	Fused	Fused	Fused
Ishium-Merus	45° ³ 14° ⁴ 10° ⁵	10°	15°	15°
Merus-Carpus	90° ¹ 159° ² 145° ³ 160° ⁴ 135° ⁵	135°	45°	55°
Carpus-Propus	130° ² 135° ³ 80° ⁴ 90° ⁵	95° planar	90° planar 45° rotatory	80° planar
Propus-Dactyl	72° ² 65° ³ 65° ⁴ 100° ⁵	60°	110°	90°

References: (1) *Homarus americanus*, Ayers & Davis 1977; (2) *Astacus leptodactylus*, Barnes 1977; (3) *Homarus* spp., Clarac 1977; (4) *Homarus americanus*, Macmillan 1975; (5) *Munida quadrispina*.

Movement analysis of interjoint coordination in B. occidentalis

The leg movements of *B. occidentalis* were most amenable to analysis of interjoint coordination (see Methods). As near as I can determine, the interjoint coordination of *L. californica* is very similar to *B. occidentalis*, and legs 2 and 3 in *E. analoga* are much like those in the albuneids; the spatial and temporal resolution of video is not sufficient to get an impression of how similar the interjoint coordination of leg 4 is in *E. analoga* compared to the albuneids.

Legs 2 and 3

Video analysis of leg segment movements in legs 2 and 3 of *B. occidentalis* showed that their interjoint coordination is very similar (Figure 3.4), as might be expected by their similar tip trajectories (Chapter 2, Interleg coordination, Tip trajectories: 21). In both legs, the levator, promotor, extensor, bender, and opener are power stroke synergists (Figure 3.5); the remoter, depressor, flexor, stretcher, and closer are return stroke synergists (Figure 3.6). This was confirmed by recording video and EMGs simultaneously and by the correlation of EMG burst with period (see EMG burst and period: 130). The movements of the merus caused by the reductor muscle are too small to notate effectively. Nonetheless, EMGs show that the reductor fires rhythmically during digging as a power stroke synergist (Figure 3.8).

In legs 2 and 3, the onset of dactyl movement (i.e., opening or closing) prevents or invades the synergistic movements of all other joints, so dactyl movement makes a convenient point for demarcating the start of both the power stroke and the return stroke. The onsets of both elevation and depression of the basi-ischium typically exceed other movements comprising the power and return strokes, respectively.

Leg 4

In *B. occidentalis*, the interjoint coordination of leg 4 differs from that of legs 2 and 3, as shown both by video analysis (Figure 3.4) and by comparing EMGs from serially homologous sets of muscles in legs 2 and 4 (Figure 3.5, Figure 3.6). For example, the

movements caused by the depressor and flexor (i.e., return stroke synergists) occur approximately simultaneously in legs 2 & 3, whereas the depressor and flexor alternate in leg 4 (Figure 3.7).

The coxa movements of leg 4 cannot be analysed using video, because *B. occidentalis* tends to tailflip when making digging leg movements in water and the abdomen curls far enough under the thorax to obscure the coxa. Consequently, coxal movements were inferred from EMGs (see Coordination of proximal joints: 96). The reductor muscle in leg 4 bursts during digging in approximate synchrony with the levator, as it does in leg 2 and 3 (Figure 3.5).

Because all of the leg muscles burst rhythmically during digging, and all but the reductor generate large movements during digging, I analysed the phase relationships of muscles controlling adjacent limb segments (except the reductor), rather than describing the coordination of each muscle to every other muscle in the leg. For leg 2 and 4 in *B. occidentalis*, I present data for all the muscles controlling the coxa and basi-ischium (Figure 3.18 to Figure 3.21), a pair of muscles controlling the basi-ischium and the carpus (depressor and flexor, respectively; Figure 3.7), the carpus and propus (extensor and bender; Figure 3.14), and the propus and dactyl (bender and closer; Figure 3.13). Data for the most of these limb segments are presented for *E. analoga*, except for the depressor and flexor in both legs 2 and 4 and extensor and bender in leg 4 (see Methods: 74).

Anecdotal observations of leg 1

The extensions and flexions of the merus are large in leg 1 of *B. occidentalis* (Table 3.1) and appear to be important in removing sand from in front of the mouthparts. These large amplitude movements tend to begin at about the same time as the gait switch occurs in the more posterior legs (Chapter 2, Interleg coordination, Bilateral coordination, *Blepharipoda occidentalis* and *Lepidopa californica*: 47). Leg 1 in *E. analoga* does not make such large extensions and flexions, perhaps because the legs would collide if they did.

The dactyl of leg 1 in *B. occidentalis* is so small that I doubt it makes any significant difference to an animal's digging ability, but both the opener and closer muscles are active rhythmically during digging. The opener bursts may occur because of the shared innervation with the stretcher (which may contribute to digging). To determine whether the closer burst is generated centrally or peripherally, I tried to immobilise the dactyl using wire and rubber bands (with questionable success), but the closer bursts continued during digging. This suggests — very tentatively — that closer activity in leg 1 is centrally generated.

Figure 3.3: Sample EW/EMG score in *B. occidentalis*

A sample EW score of digging leg movements for *B. occidentalis*, aligned with simultaneously recorded leg 2 proximal muscle EMGs. Full notation shown for leg 2; simplified score shown for leg 3, indicating the timing of joint movements, but not the spatial positions of the leg segments. Leg 4 was not moving in this sequence. Movements of the merus are too small to be notated. Power stroke movements shaded in grey. Double lines indicate beginning and end of movements; numbers in parentheses indicate positions; arrows signify direction of movement; numbers with opening parenthesis only is a “mute” position, mainly for reminder; “X” = flexion; “R” = reversal of flexion (i.e., extension); “‡” = ½ unit of movement (i.e., 11.25°); “m” = minimal movement; “□” = limbs forming an opposition (i.e., close but not touching); “=” = release of opposition [Eshkol 1980]. For more details on EW scores, see Appendix A, Eshkol-Wachman movement notation (pg. 259). EMGs are listed in the “backward walking” sequence shown in Figure 3.15A to facilitate comparison between the walking and digging sequences, unlike most other figures, where EMGs are shown in a proximal to distal order.

$\theta = 22.5^\circ$
 $T(1) = 33.3 \text{ ms (1 video frame)}$
 Front = (0)

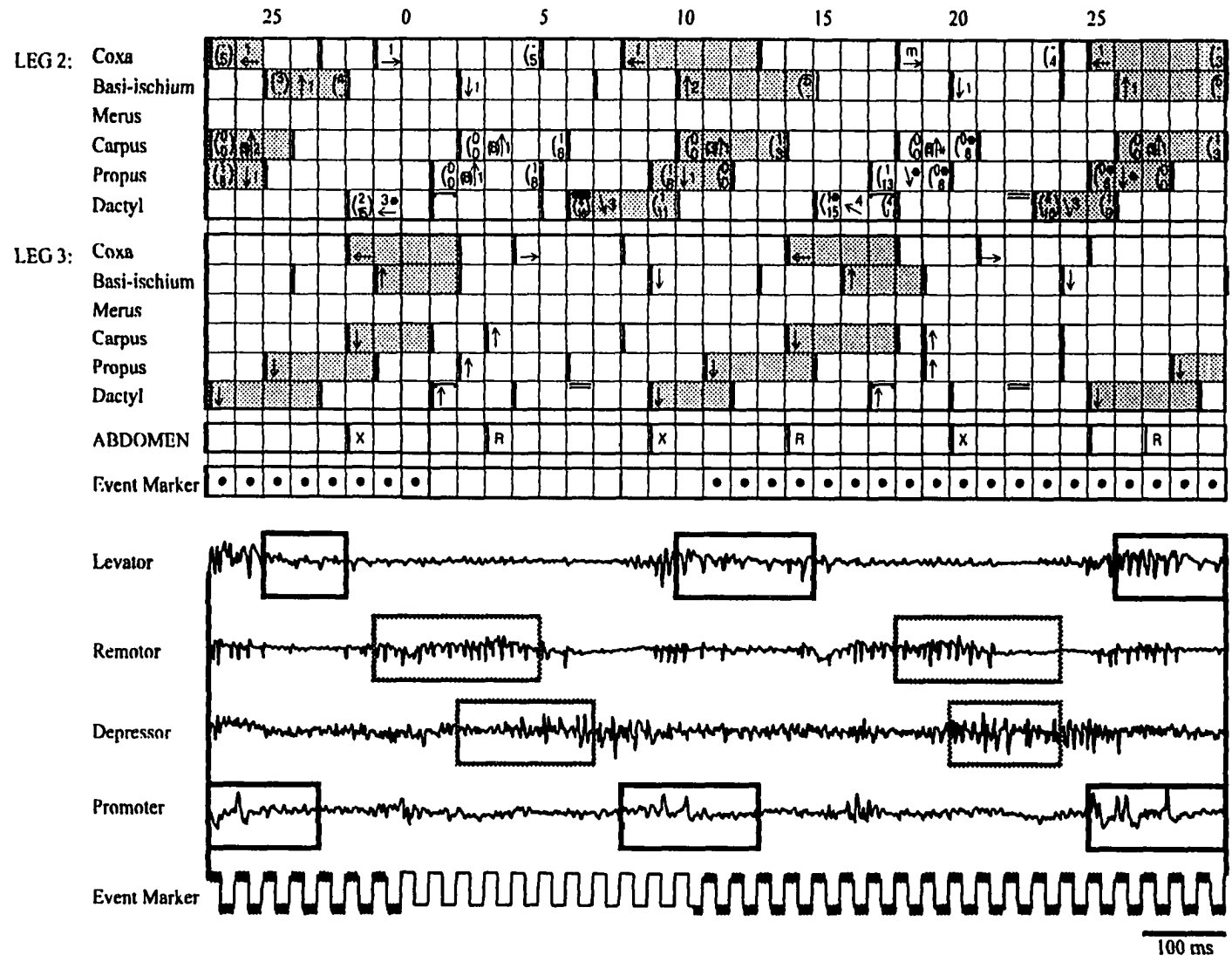
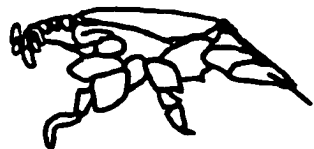
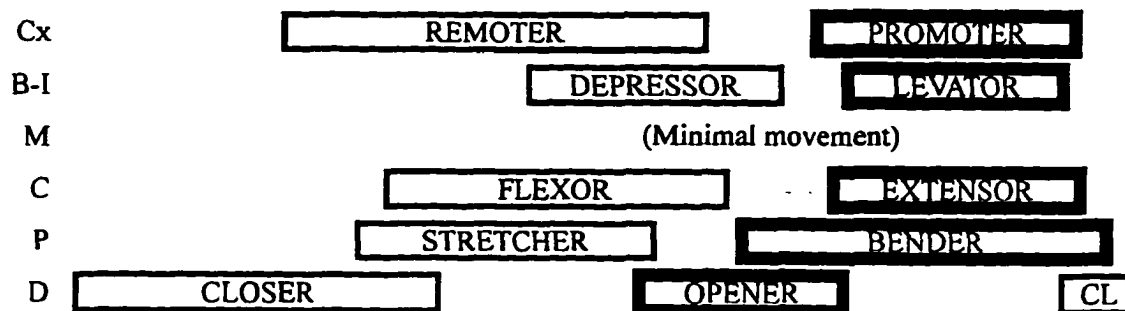


Figure 3.4: Interjoint coordination of *B. occidentalis*

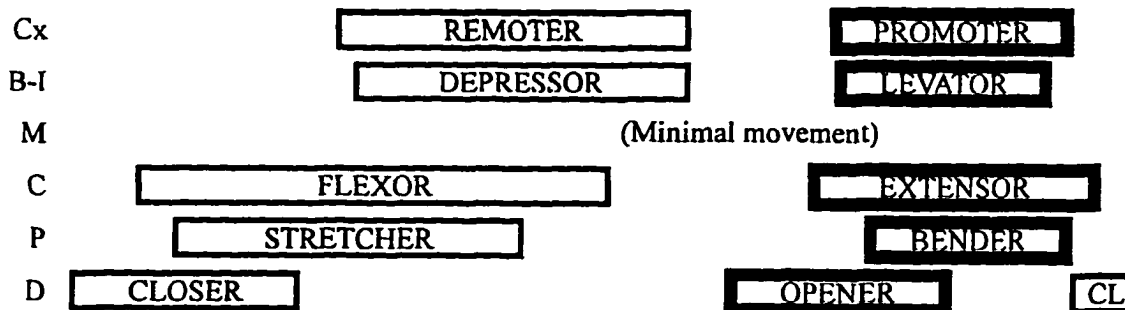
Interjoint coordination in legs 2, 3 and 4 in *B. occidentalis*: a general, non-quantitative description of the behaviour. Movements of individual leg segments (abbreviated at left) comprising digging leg movements in (A) leg 2, (B) leg 3, and (C) leg 4. Boxes indicate movement of leg segment. Muscles listed inside boxes are those predicted to be responsible for the movement; thus, this figure is both a description of leg movements and a prediction of timing of leg EMG bursts. *A-B*: Thin boxes enclose leg segment movements comprising the return stroke; thick boxes enclose leg segment movements comprising the power stroke; *C*: thick grey boxes show the movements in leg 4 produced by the muscles that are serial homologues to those generating the power strokes in legs 2 and 3. The movement of the basi-ischium is too small to notate in any of the legs (see Table 3.1, Figure 3.8); the coxa in leg 4 is obscured by the tailfan and could not be analysed (see Coordination of proximal joints: 112). The phasings are all shown relative to the onset of the closer-generated movement in order to compare the interjoint coordination of the legs; consequently, this figure does not show normal interleg coordination (see Chapter 2, Interleg coordination, Ipsilateral coordination: 36). Compare with sequences in other figures in this chapter. Average start and end phases of three complete strokes in one individual, with the closing of the dactyl defining the start of the cycle. Cx = coxa; B-I = basi-ischium; M = merus; C = carpus; P = propus; D = dactyl (same abbreviations in subsequent figures containing movement analyses).



(A) LEG 2



(B) LEG 3



(C) LEG 4

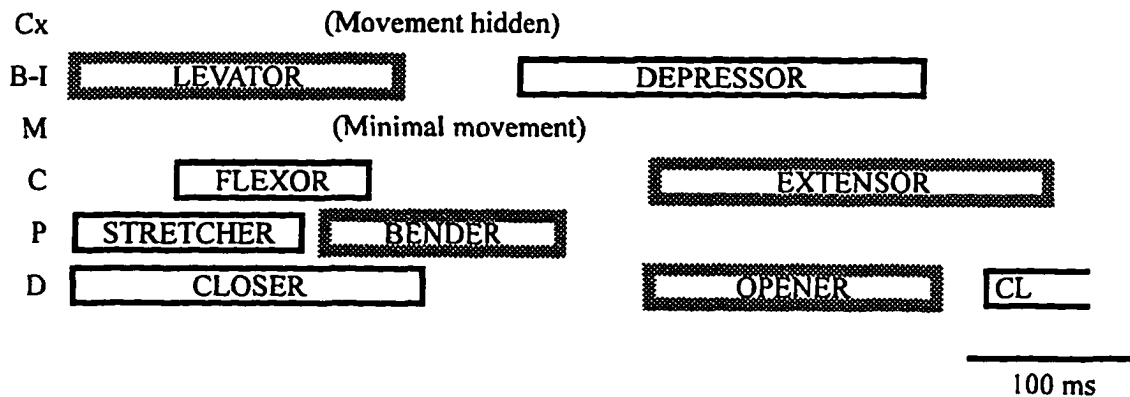


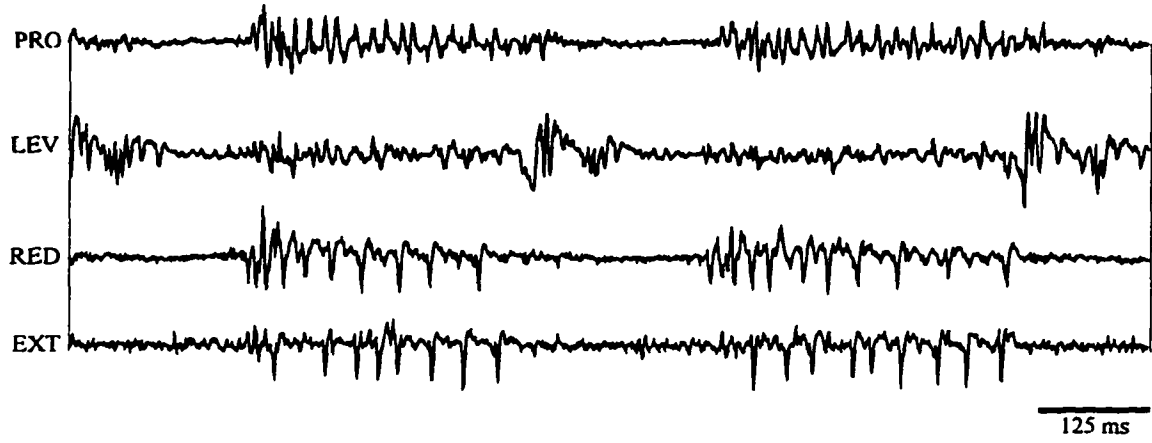
Figure 3.5: Power stroke synergists

Leg 2 power stroke synergists are not synergists in leg 4 in *B. occidentalis*.

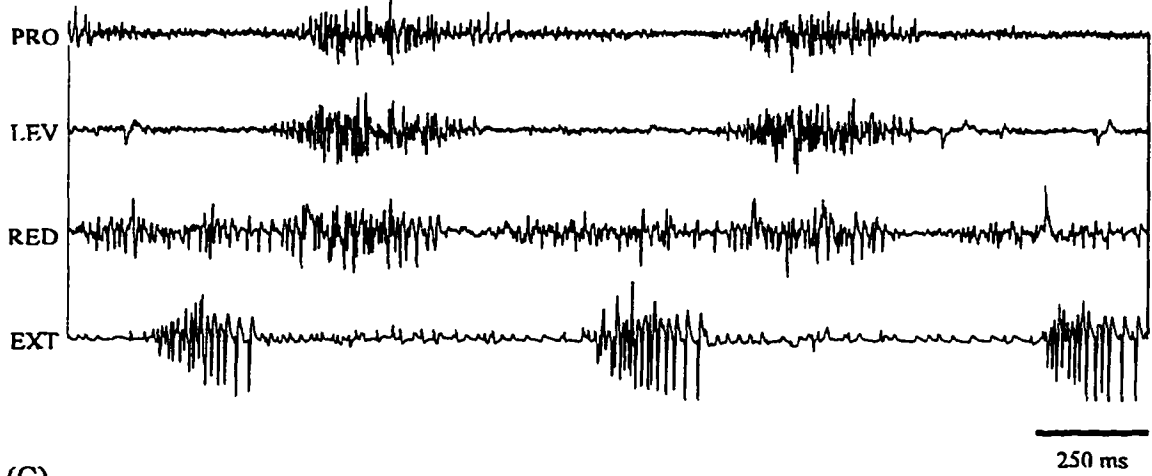
(A) Simultaneous EMGs of muscles in leg 2 and (B) the segmentally homologous muscles in leg 4. (C) Leg 4 EMGs recorded from a different individual than *B*. Two digging sequences for leg 4 are shown to emphasise that leg 4 makes regular, rhythmic movement during digging, unlike its erratic movement above sand (Chapter 2, Tip trajectories: 21). Note that the levator and extensor movements are synchronous in *A*, but alternate in *B* and *C*. Similarly, the promotor burst invades the levator burst in *A* but exceeds them in *B* and *C*.



(A)



(B)



(C)

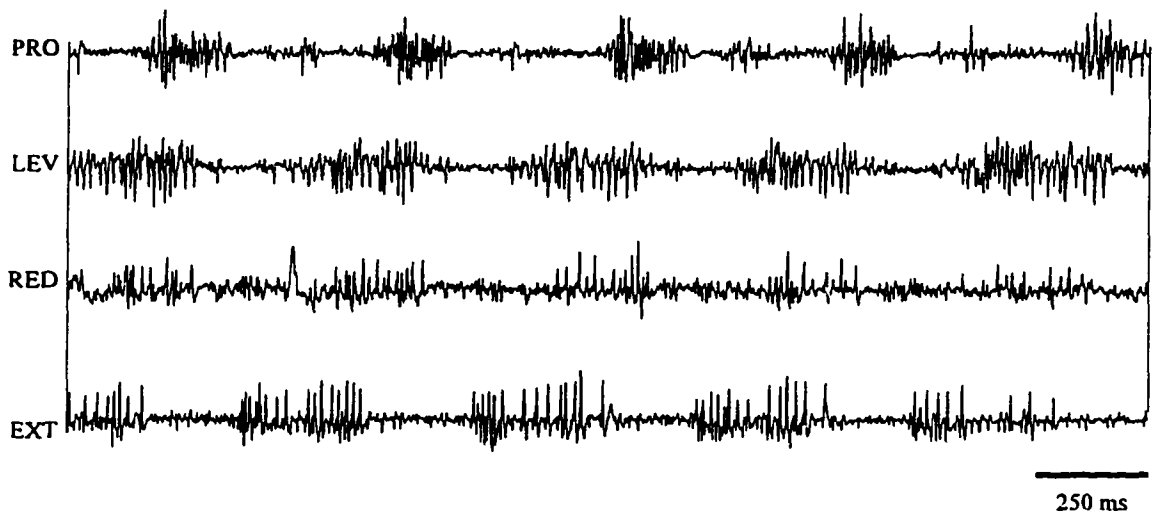
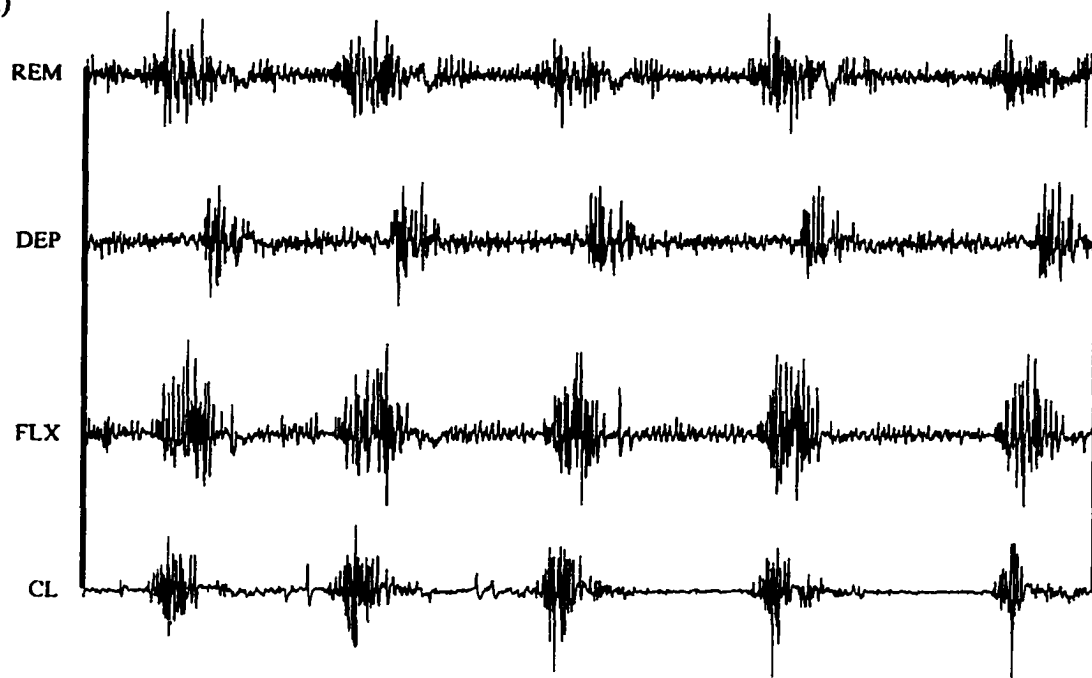


Figure 3.6: Return stroke synergists

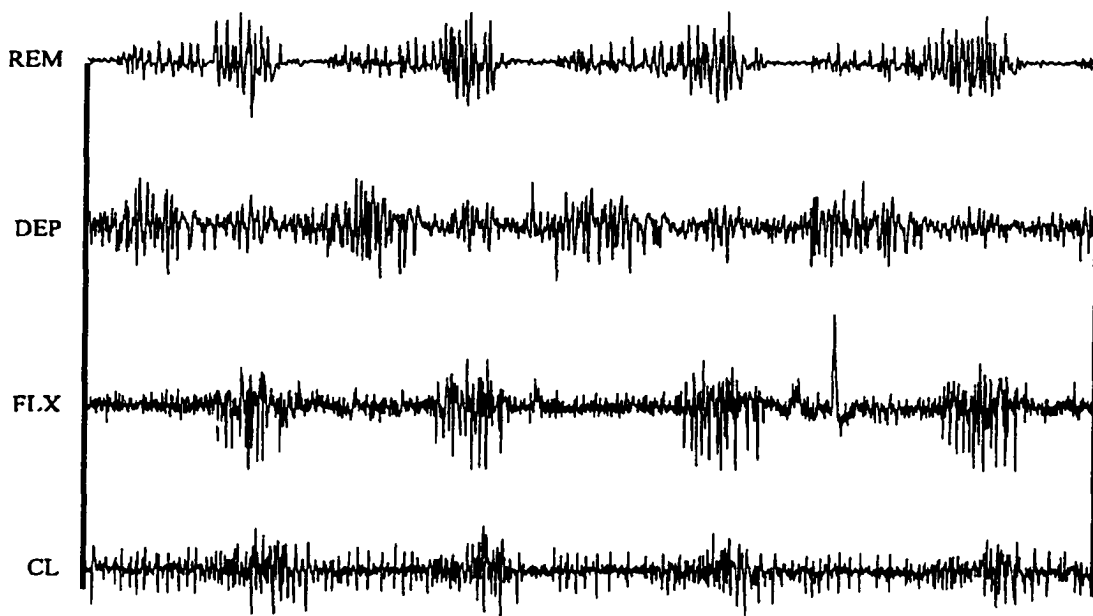
Leg 2 return stroke synergists are not synergists in leg 4 in *B. occidentalis*. (A) EMGs from return stroke muscles in leg 2 and (B) from segmentally homologous muscles in leg 4. Note that the flexor and depressor bursts are almost synchronous in *A*, but alternate in *B*. Similarly, the remotor burst invades depressor bursts in *A* but exceeds them in *B*.



(A)



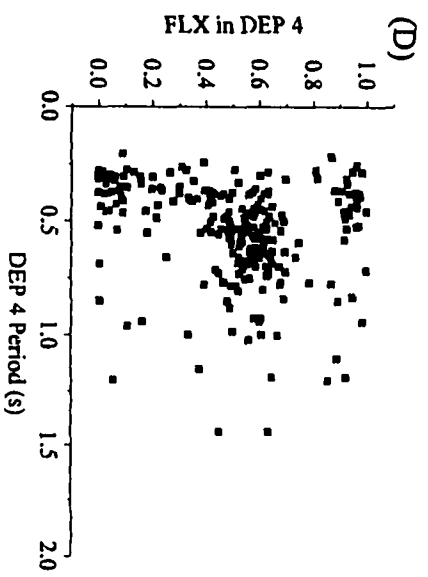
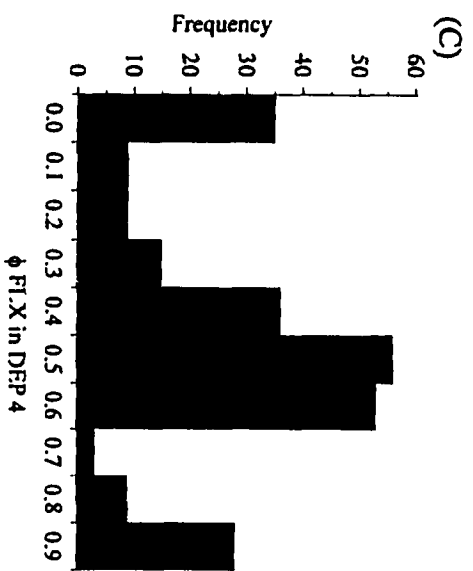
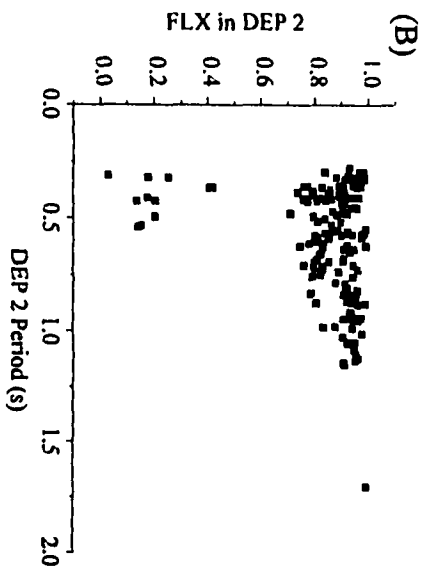
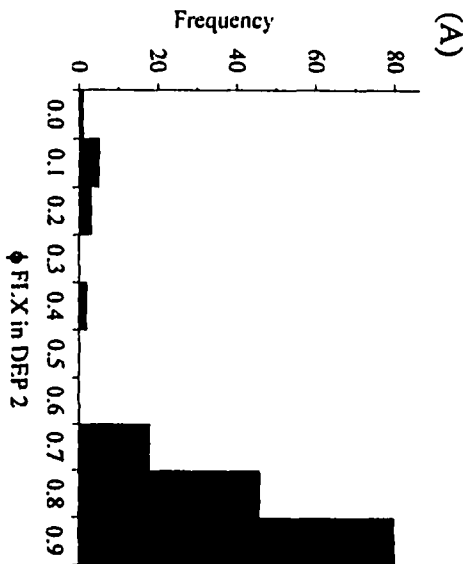
(B)



250 ms

Figure 3.7: FLX and DEP coordination in *B. occidentalis*

An example of a quantitative difference in EMG activity of leg 2 and 4 in *B. occidentalis*. Phase analysis of the flexor burst onset relative to depressor burst period. (A-B) Phase histograms of FLX in DEP in (A) leg 2 and (B) leg 4. (C-D) Phase/period plots of FLX in DEP in (C) leg 2 (same data as A) and (D) leg 4 (same data as B). These phase/period plots show whether phase changes as animal speeds up or slows down. n = (A, C) ten digs by three animals; (B, D) 16 digs by two animals.



Correlating movements and motor patterns above and below sand

The correlation between the movement produced and the motor output in the form of EMGs is good in most cases (e.g., Figure 3.3, Figure 3.8 to Figure 3.12). The one exception is the correlation of the movements and EMGs generated by the stretcher and opener muscles, a special case described in more detail elsewhere (Opener and stretcher EMGs: 148). The EMG bursts generally convade the movements they produce, which is expected due to the delay between the muscle's electrical activity and the development of tension. In some cases, the movement appears to end before the EMG burst. This may be because the movement was not adequately resolved on video, since the end of the movements and of the bursts are within 1-2 frames (33-66 ms) of each other. Alternately, the limb segment may have reached the anatomical limit of the joint (Table 3.1).

Interjoint coordination in a single leg changes little in the transition from swimming to digging. The same temporal (but not necessarily phase) relationships recorded in water with video and EMGs were evident in EMGs recorded when the same individual was digging. Phase relationships may not be constant between any pair of movements or EMG bursts because the power strokes of legs 2 and 3 tend to covary with period, whereas the return strokes do not (see EMG burst and period: 130). The motor output is not identical when individuals are above and below sand, however. Both the frequency and amplitude of EMG potentials are greater when an animal is digging in sand than when it makes digging-type leg movements in water (e.g., Figure 3.8 to Figure 3.12, Figure 3.27).

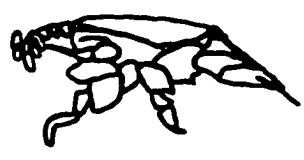
Comparing coordination of B. occidentalis and E. analoga

In leg 2, the interjoint coordination of *E. analoga* is generally similar to that of *B. occidentalis*: the bender, extensor, levator, and promotor function as power stroke synergists, and the closer, flexor, remoter, and depressor act as return stroke synergists. There is less overlap between the reductor and bender bursts in *E. analoga* than in *B. occidentalis* (Figure 3.8), but because the reductor-generated movement is so small in both species, this probably does not indicate any important functional differences

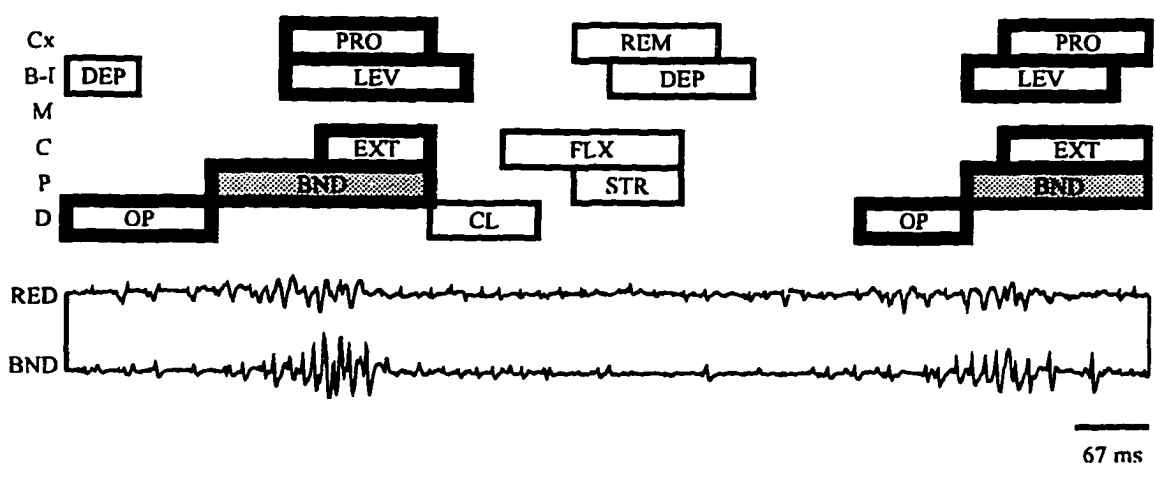
(although it suggests interesting physiological differences). Representative EMGs are shown in Figure 3.8, Figure 3.10, Figure 3.16, and Figure 3.17, and quantitative analyses for the distal joint muscles are shown in Figure 3.13 and Figure 3.14. Because of the difficulty in recording from leg 4 in *E. analoga*, however, the data are equivocal on how similar the leg 4 motor pattern is in the two species, particularly for the distal leg muscles (see Methods). The similarity in proximal muscle EMGs is described below.

Figure 3.8: RED and BND in *B. occidentalis* and *E. analoga*

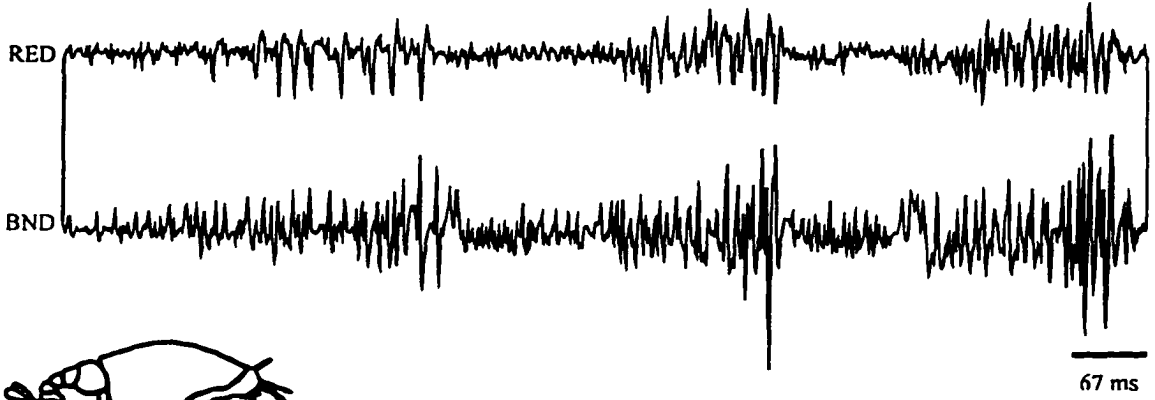
Reductor and bender activity in *B. occidentalis* and *E. analoga*. (A) Combined video and EMGs recorded from leg 3 of *B. occidentalis* making leg movements in water. The movements of the basi-ischium are too small to notate, but EMGs show that the reductor bursts during the power stroke component of the leg movement (Figure 3.5). (B) EMGs from same individual digging in sand have the same pattern. (C) Leg 2 EMGs from reductor and bender in *E. analoga*. This record shows an unusual mismatch in number of bursts, with one “additional” reductor burst more than the number of bender bursts. Double arrows indicate corresponding bursts; bullet at end of arrow indicates extra reductor burst. Same vertical scale in A and B. RED = reductor; BND = bender.



(A)



(B)



(C)

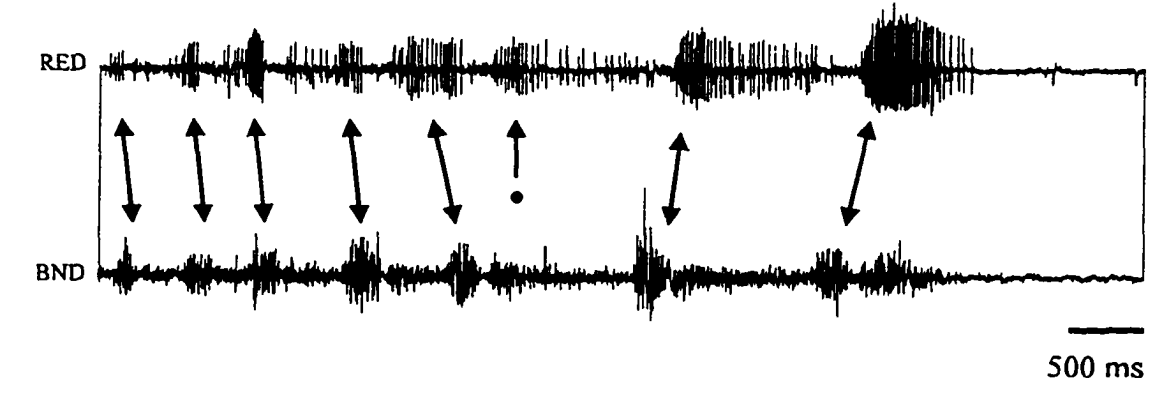
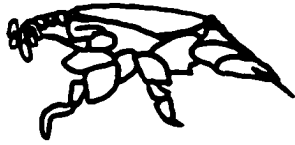
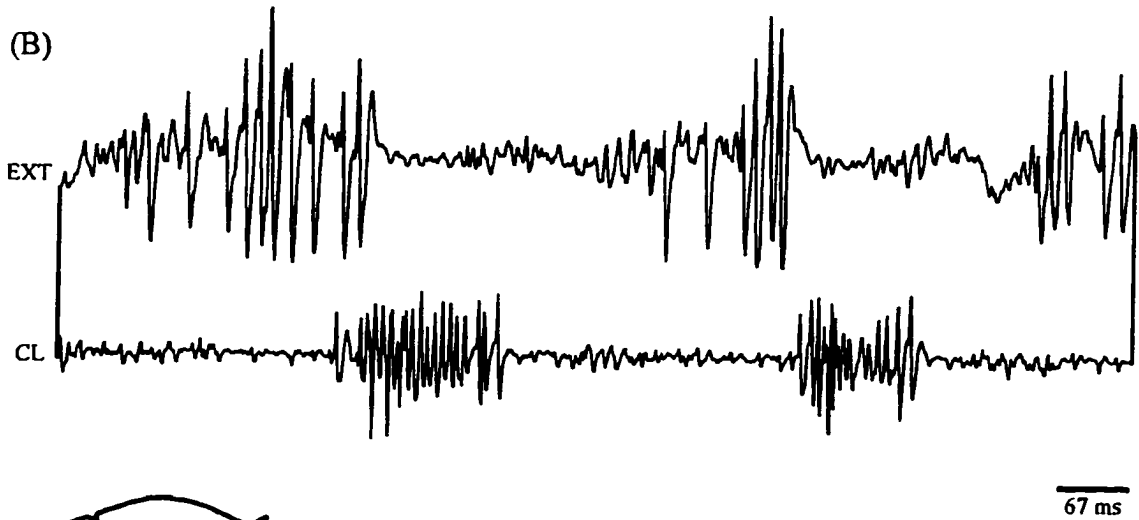
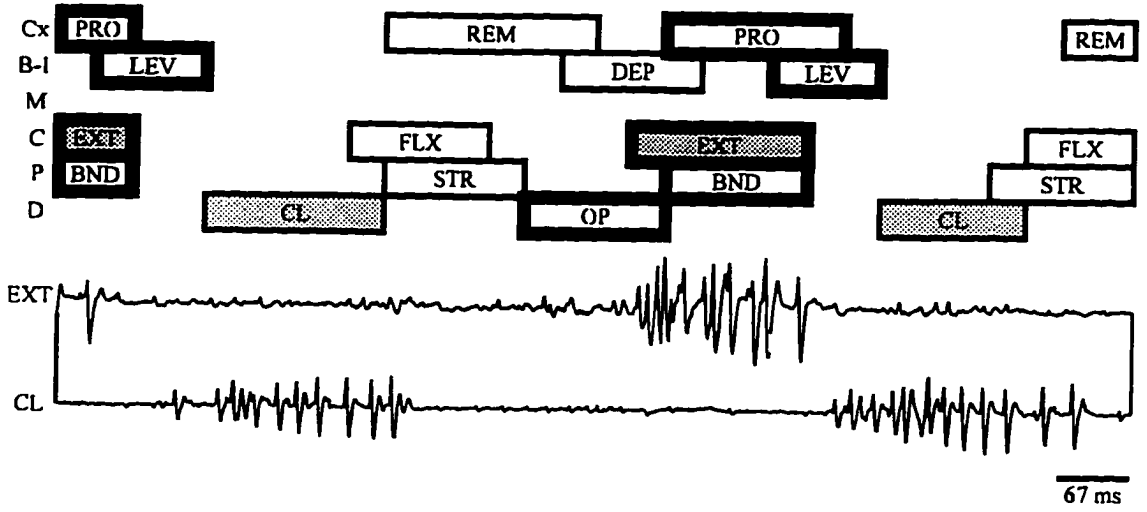


Figure 3.9: EXT and CL in *B. occidentalis* and *E. analoga*

Extensor and closer activity in *B. occidentalis* and *E. analoga*. (A) Simplified movement analysis of video record of *B. occidentalis* above sand and simultaneously recorded EMGs. (B) EMGs from same individual digging. (C) EMGs in *E. analoga* recorded during digging. The timing between the EMGs is similar above and below sand in *B. occidentalis* (A, B) and in *B. occidentalis* (B) and *E. analoga* (C). Same vertical scale in A and B.



(A)

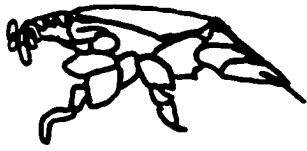


(C)

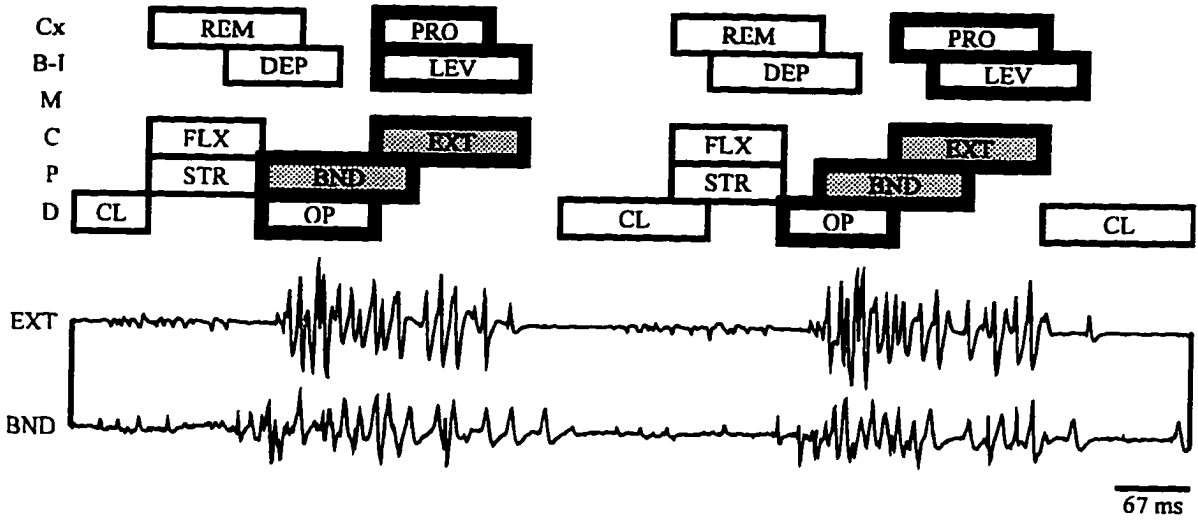


Figure 3.10: EXT and BND in *B. occidentalis* and *E. analoga*

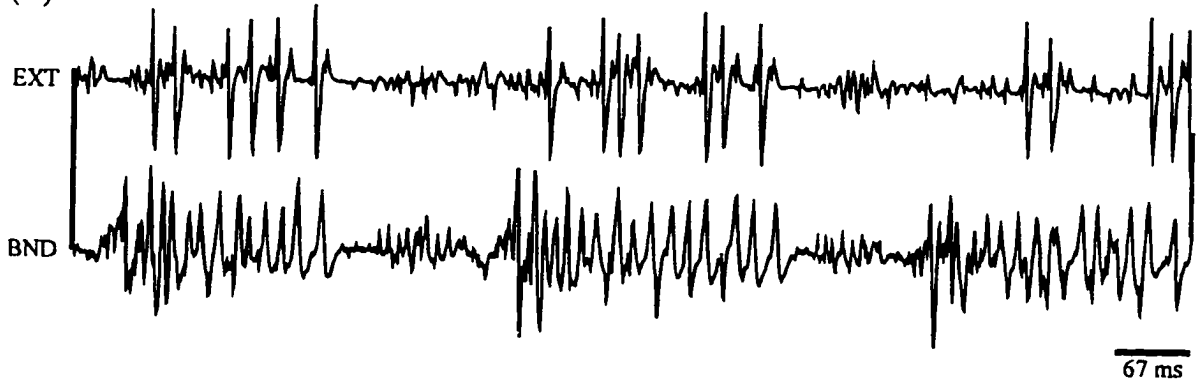
Extensor and bender activity in (A-B) *B. occidentalis* and (C) *E. analoga*. (A) Simplified movement analysis of video record of *B. occidentalis* above sand and EMGs recorded simultaneously. (B) EMGs from same individual digging. (C) EMGs recorded during digging sequence in *E. analoga*. The temporal relationships between the EMGs are similar above and below sand in *B. occidentalis* (A, B); the timing is also similar in *B. occidentalis* (B) and *E. analoga* (C). Same vertical scale in A and B.



(A)



(B)



(C)

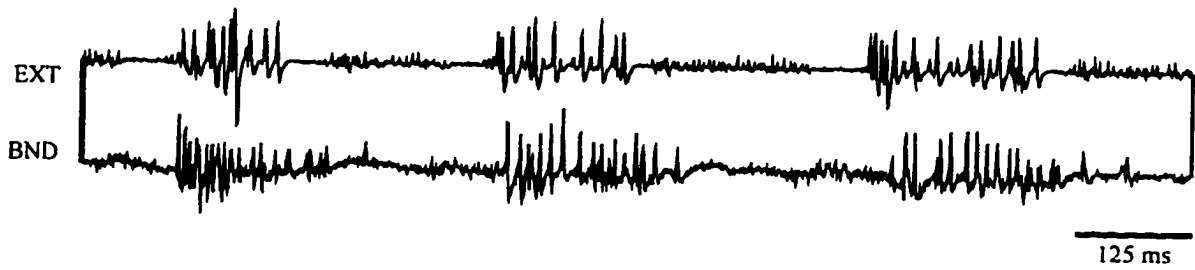
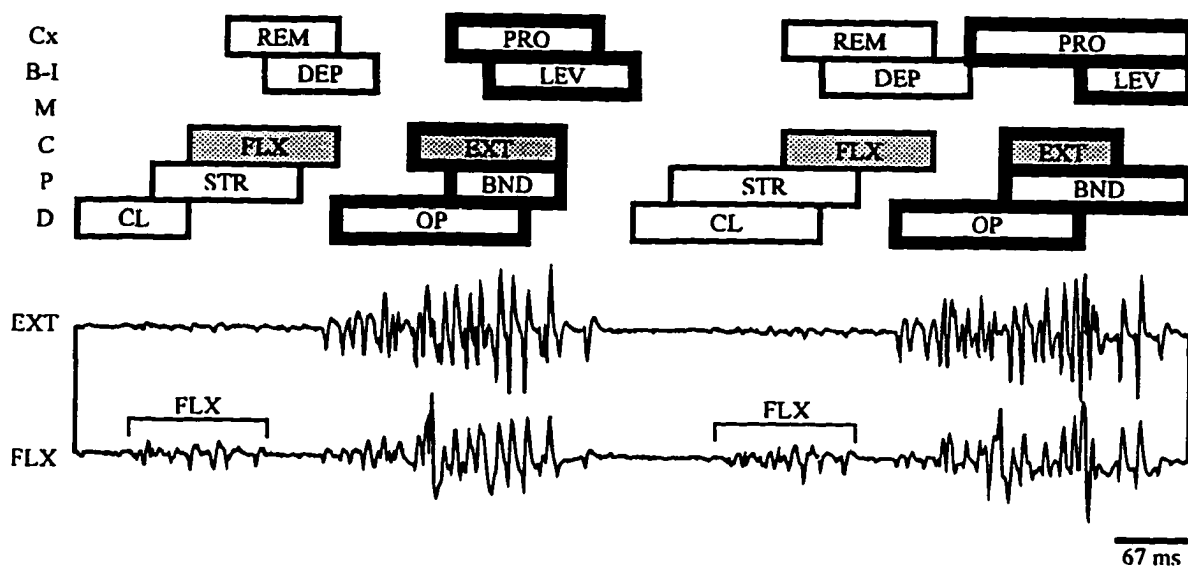


Figure 3.11: EXT and FLX in *B. occidentalis*

Extensor and flexor activity in *B. occidentalis*. (A) Simplified movement analysis of video record of *B. occidentalis* above sand and EMGs recorded simultaneously. (B) EMGs from same individual digging. "Cross-talk" from the extensor muscle is present in the flexor EMG recording. Like antagonistic muscles in insects [Dean 1992], these EMG bursts alternate, showing no co-activation. Same vertical scale in *A* and *B*.



(A)



(B)

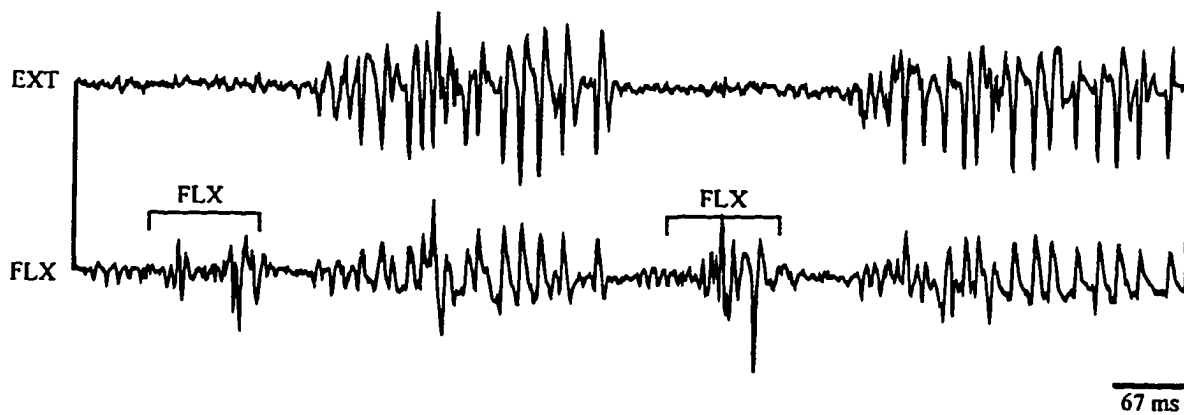
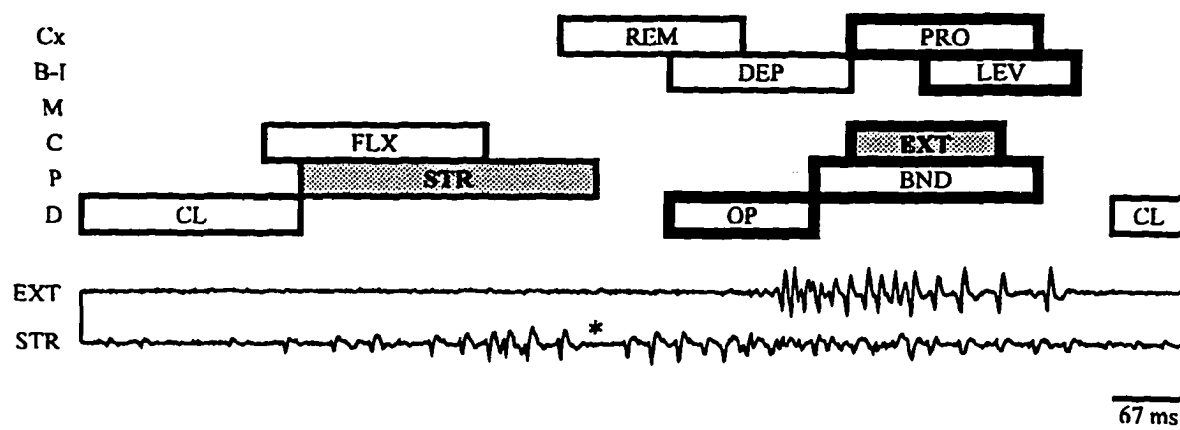


Figure 3.12: EXT and STR in *B. occidentalis*

Extensor and stretcher activity in *B. occidentalis*. (A) Simplified movement analysis of video record of *B. occidentalis* above sand and EMGs recorded simultaneously. (B) EMGs from same individual digging. Asterisk indicates brief drop in potential frequency in stretcher burst that occurs at about the point the stretcher-generated movement stops and the opener-generated movement begins; the opener and stretcher muscles are innervated by only a single, shared excitatory motor neuron (see Opener and stretcher EMGs: 148). Same vertical scale in *A* and *B*.



(A)



(B)

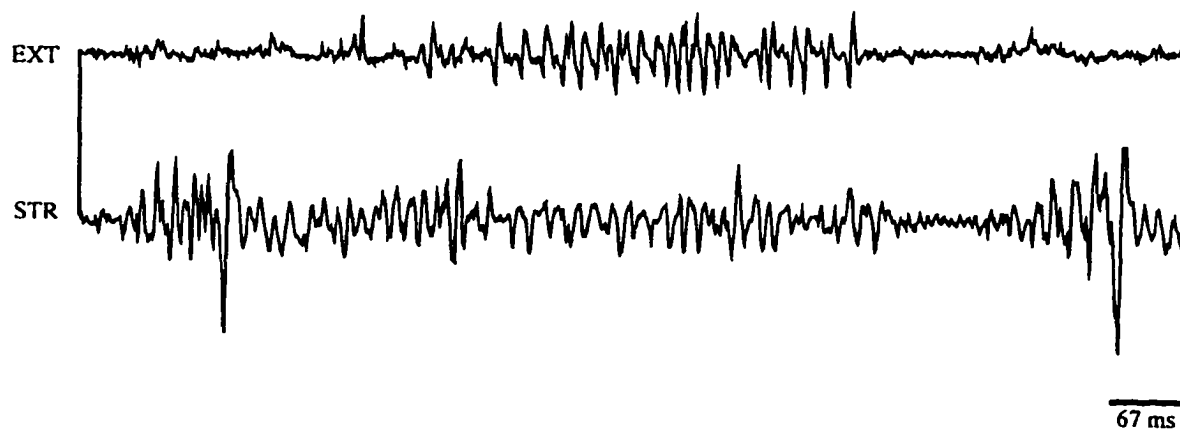


Figure 3.13: Phase of CL in BND in *B. occidentalis* and *E. analoga*

Similar phases of leg 2 closer onset in bender period in (A, C, E, G) *B. occidentalis* and (B, D, F, H) *E. analoga*, and a small difference between leg 2 and 4 in *B. occidentalis*. Leg 2 closer in bender (A-B) phase histograms and (C-D) phase/period plots, and leg 4 (E-F) phase histograms and (G-H) phase/period plots for the serially homologous muscles. In *B. occidentalis*, the phase histograms in A and E have similar distributions, but the high phase values tend to occur at long periods in leg 2 (C) but short periods in leg 4 (G). Although the phase histograms in A and E are similar, the phase/period plots show that bursts are more likely to be synchronous at long periods in A and C but at short periods in E and G. n = (A, C) 20 digs by three animals; (E, G) 18 digs by four animals; (B, D) 19 digs by four animals; (F, H) six digs by one animal.

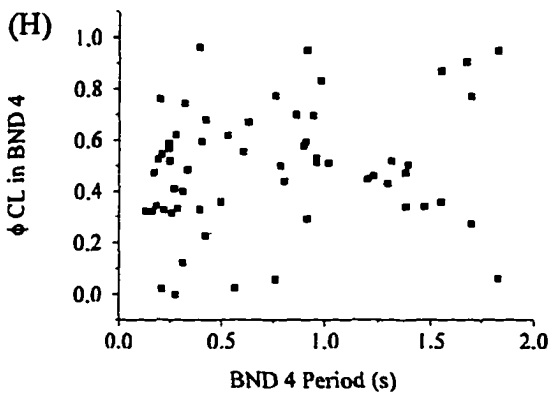
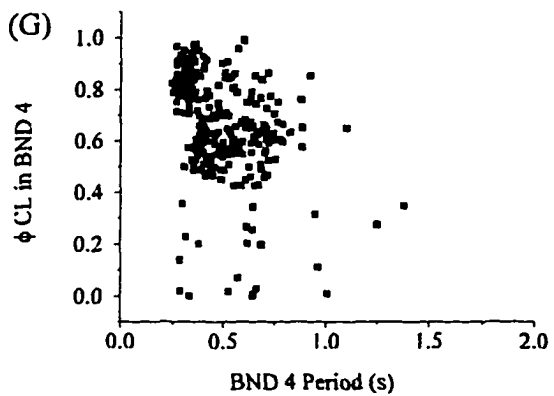
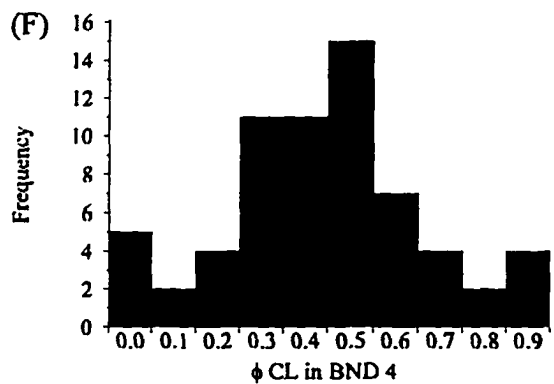
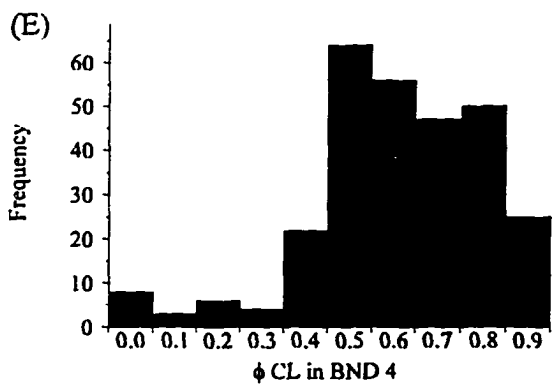
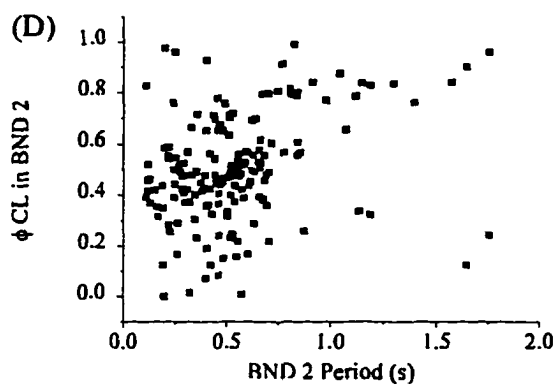
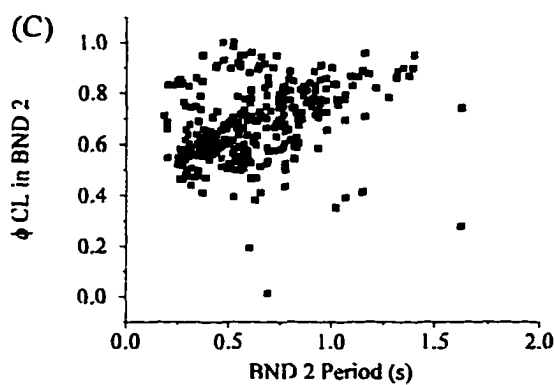
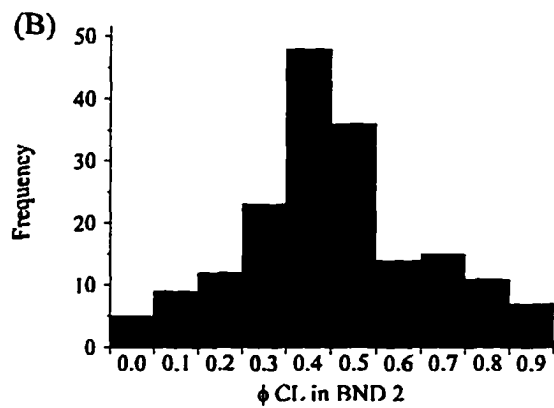
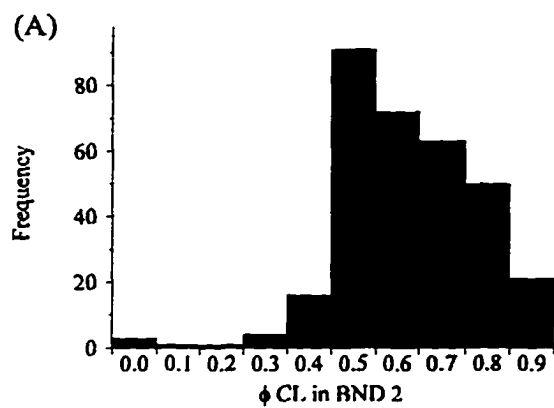
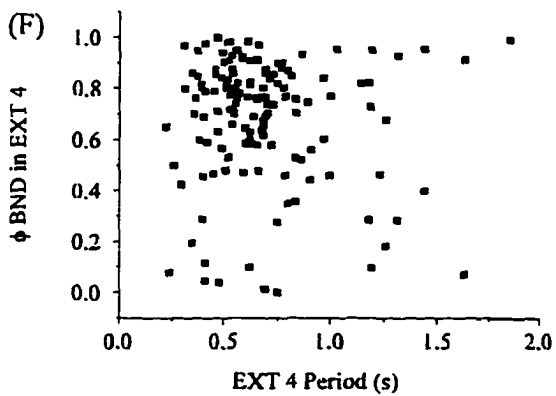
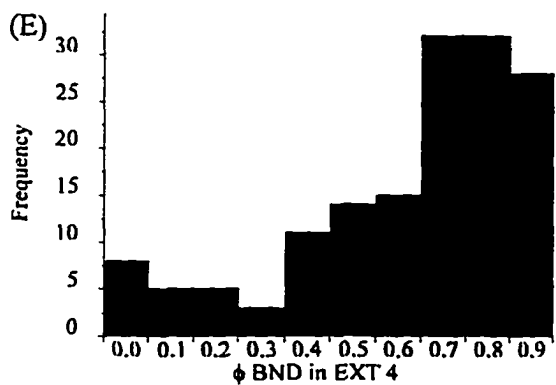
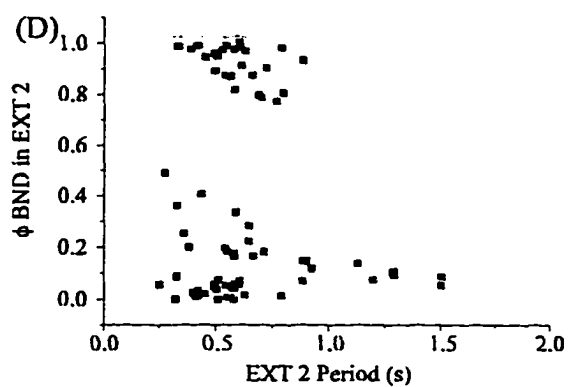
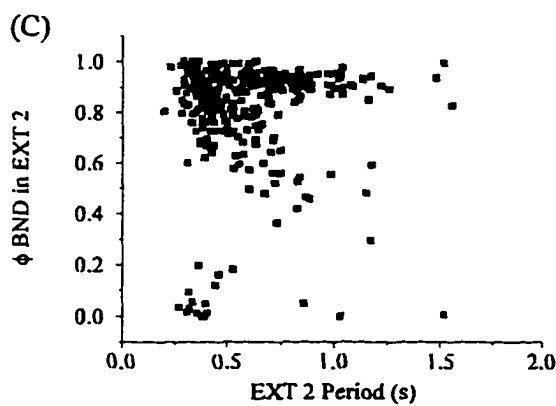
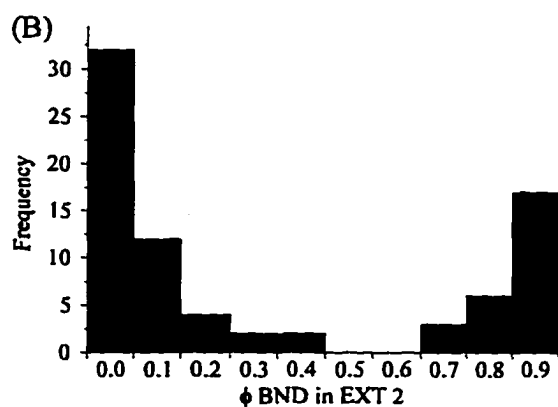
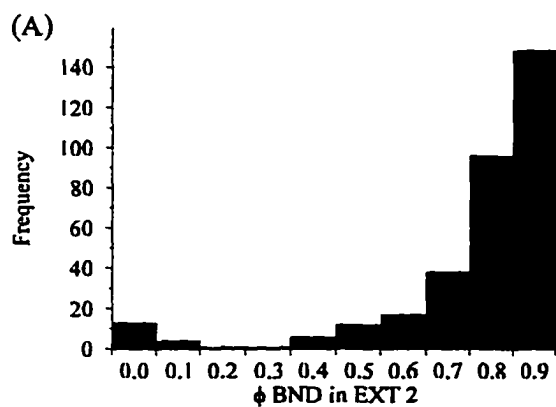


Figure 3.14: Phase of BND in EXT in *B. occidentalis* and *E. analoga*

Phase plots showing the similar motor output of the leg 2 bender onset in extensor period in (A, C) *B. occidentalis* and (B, D) *E. analoga*, and no obvious difference between leg 2 and (E, F) leg 4 in *B. occidentalis*. n = (A, C) 17 digs by three animals; (B, D) ten digs by two animals; (E, F) ten digs by two animals.



Coordination of proximal joints

I was particularly interested in quantifying the coordination of the proximal joints in sand crabs for two reasons. First, the video analysis of the movements of proximal leg 4 segments in *B. occidentalis* was incomplete because the coxa was obscured by the abdomen. In *E. analoga*, the proximal joints of all the legs are completely covered by the telson, and I could not analyse the movements. Second, proximal joint movements are very important in walking in other decapod crustaceans [Ayers & Davis 1977; Barnes 1977; Clarac 1984; Evoy & Ayers 1982; Macmillan 1975; Sillar et al. 1986, 1987], so the coordination of the proximal joints in sand crabs could provide important evidence for or against the hypothesis that digging is a modified form of walking.

During backward walking, the promotor and depressor muscles are power stroke synergists, and the levators and remoters are return stroke synergists [Clarac 1984]. This pairing is reversed during forward walking, when the remoters and depressors are power stroke synergists, and the levators and promotors are return stroke synergists (Figure 3.15). Although it has not often been stressed, walking leg movements would not be functional if the synergists conduced. For example, depression convades remotion during forward walking [Ayers et al. 1994]. Likewise, the start of leg promotion or remotion (in forward or backward walking, respectively) must not begin before the start of the leg's elevation or the leg tip would be dragged across the substrate. The sequence of the start of each individual joint movement is elevation, remotion, depression, and promotion for backward walking, and elevation, promotion, depression, and remotion for forward walking [Macmillan 1975; see also Figure 3 in Clarac 1984; Figure 2 in Chrachri & Clarac 1990]. Thus, the sequence of proximal muscle activation is reversed for forward and backward walking: e.g., remotion exceeds elevation during backward walking, but invades elevation during forward walking. Therefore, the onset phases of proximal muscle EMG bursts controlling proximal joints should be significantly lower in leg 2 than the phases of the same pair of muscles in leg 4. This is the case: in both *B. occidentalis* and *E. analoga*, the mean phases between the proximal muscles in leg 2 are significantly lower than the

mean phases of same pairs of muscles in leg 4 (Table 3.2). In one case (phase of levator onset in promotor period in leg 2 and 4 of *B. occidentalis*), the data have a bimodal distribution where, $\phi \approx 0$ and $\phi \approx 1$ (Table 3.3, Figure 3.18, Figure 3.19), but because these phases are equivalent (i.e., near synchrony), the statistical difference may not reflect a biological difference. Nevertheless, the data imply that the proximal joint pattern of leg 2 (and presumably leg 3) is similar to that of backward walking, but that of leg 4 is more similar to forward walking.

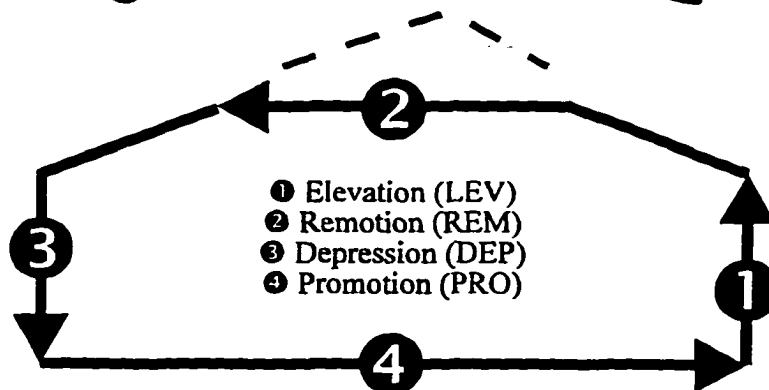
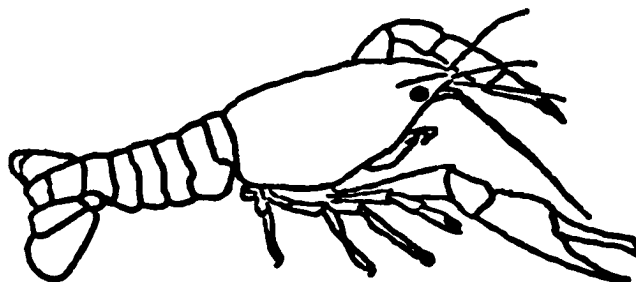
In leg 2 in *B. occidentalis*, not all of the phase relationships are constant (Figure 3.20). The increasing phase of remoter onset with levator period (Figure 3.20A) probably occurs because power stroke duration (which the levator is part of) increases with period, whereas return stroke does not (see EMG burst and period: 130). The phase shift of depressor relative to remoter (Figure 3.20B) is less easily explained.

Figure 3.15: Sequence of proximal joint movements during walking

Sequence of proximal leg segment movements during (A) backward and (B) forward walking in macrurans. The movements (and the EMG onsets) follow the bulleted sequence shown within the leg trajectories (arrows), although there is overlap in both the movements and EMG bursts. Note that when comparing the relative timing of any interjoint movements (either promotor or remotor with levator or depressor) that the timing in one direction (i.e., backward) is the reverse of that in the other direction. For example, onset of depression follows remotion in backward walking, but depression precedes remotion in forward walking. Numbers = sequential movements generated by proximal muscles.

(A)

Backward walking



(B)

Forward walking

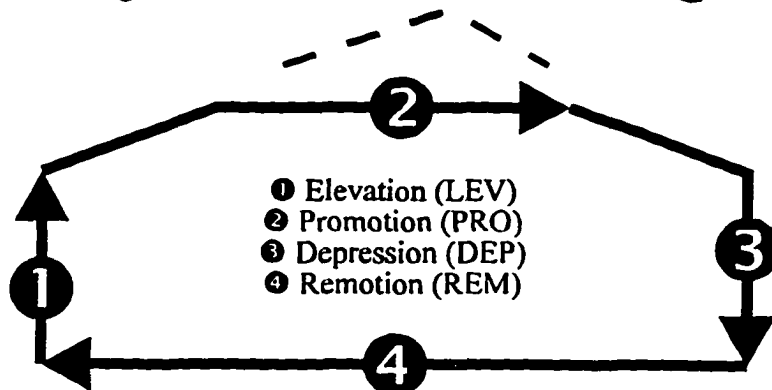
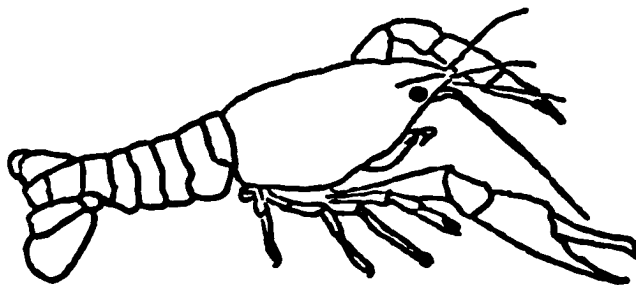


Table 3.2: Mean phases of leg 2 proximal muscles and leg 4 proximal muscles in *B. occidentalis* and *E. analoga*

Mean phase values of EMG burst onset in individual muscles controlling one proximal joint relative to the EMG burst onset of a muscle controlling the other proximal joint in *B. occidentalis* and *E. analoga*. The mean phases of leg 2 and leg 4 are significantly different in all cases (t-test, $p < 0.05$), but the difference between the phase of the levator relative to the promotor (LEV in PRO; *) in leg 2 and 4 may not be biologically relevant, because the phase histograms for both leg 2 (Figure 3.18) and leg 4 (Figure 3.19) have a bimodal distribution with most of the data near 0 and 1, which are equivalent phases (i.e., synchrony). Same data for Figure 3.18 to Figure 3.21.

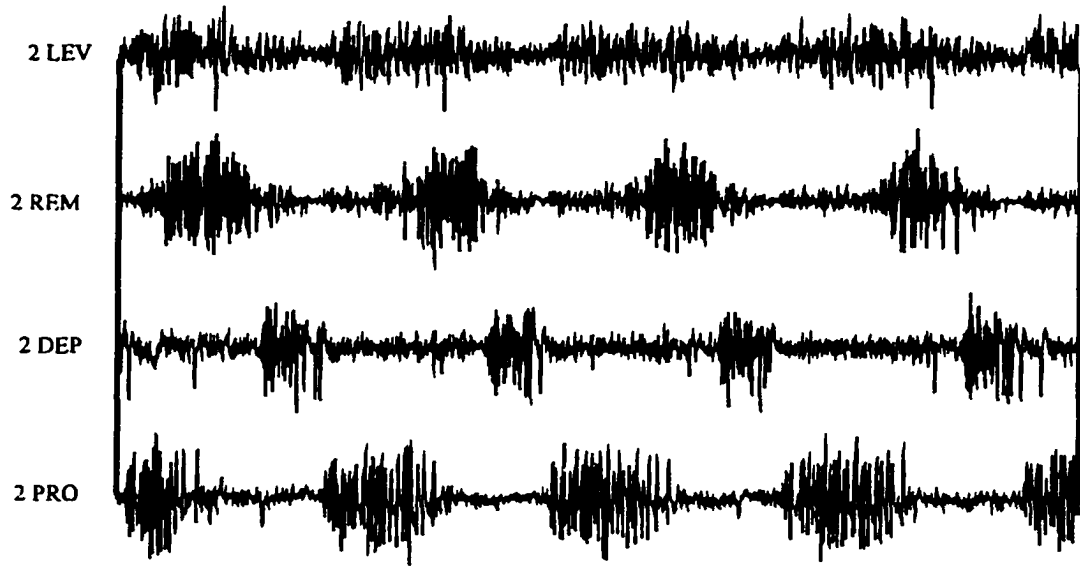
Table 3.2

Species	Muscles	t value	Leg	Mean phase	Variance	n
<i>B. occidentalis</i>	REM in LEV	t = 7.861	Leg 2	0.3799	0.05991	507
			Leg 4	0.5451	0.07284	201
	DEP in REM	t = 19.97	Leg 2	0.3986	0.03601	480
			Leg 4	0.7140	0.08318	474
	PRO in DEP	t = 21.14	Leg 2	0.2576	0.02655	335
			Leg 4	0.5736	0.05677	492
	LEV in PRO	t = 9.223*	Leg 2	0.3017	0.1498	467
			Leg 4	0.5772	0.1668	280
<i>E. analoga</i>	REM in LEV	t = 2.322	Leg 2	0.3868	0.06999	176
			Leg 4	0.4646	0.08453	109
	DEP in REM	t = 11.43	Leg 2	0.3901	0.0717	167
			Leg 4	0.7186	0.09479	277
	PRO in DEP	t = 9.807	Leg 2	0.4651	0.07708	187
			Leg 4	0.7118	0.06516	271
	LEV in PRO	t = 3.536	Leg 2	0.4000	0.1233	223
			Leg 4	0.5305	0.08203	124

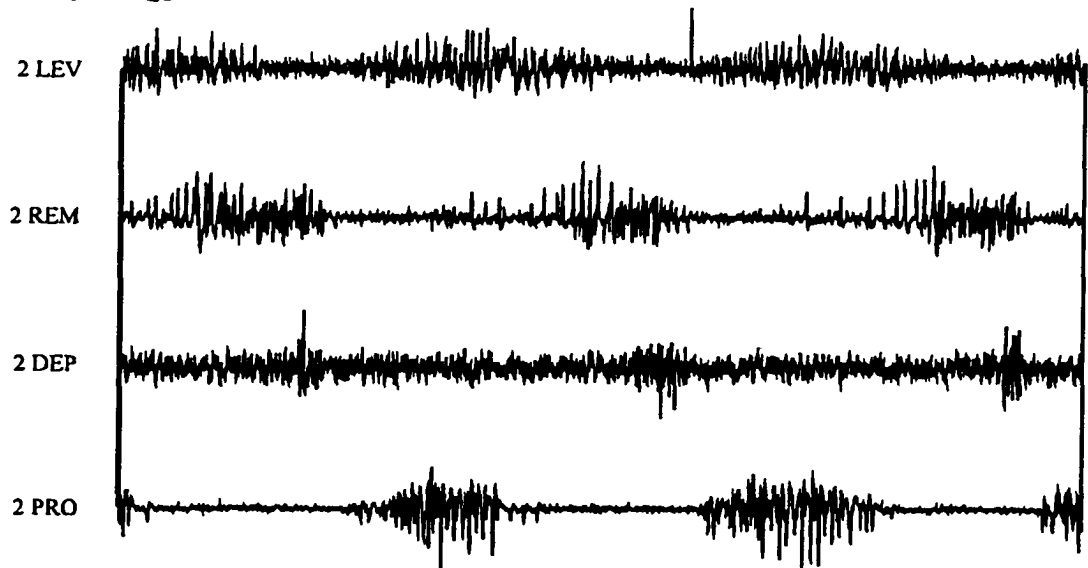
Figure 3.16: EMGs of leg 2 proximal muscles in *B. occidentalis* and *E. analoga*

Leg 2 proximal muscle EMGs in (A) *B. occidentalis* (see also Figure 3.3) and (B) *E. analoga*. EMGs are listed in the “backward walking” sequence shown in Figure 3.15A to facilitate comparison between the walking and digging sequences, unlike previous figures, where EMGs are shown in a proximal to distal order. Compare with Figure 3.3 and Figure 3.17.

(A)



(B)



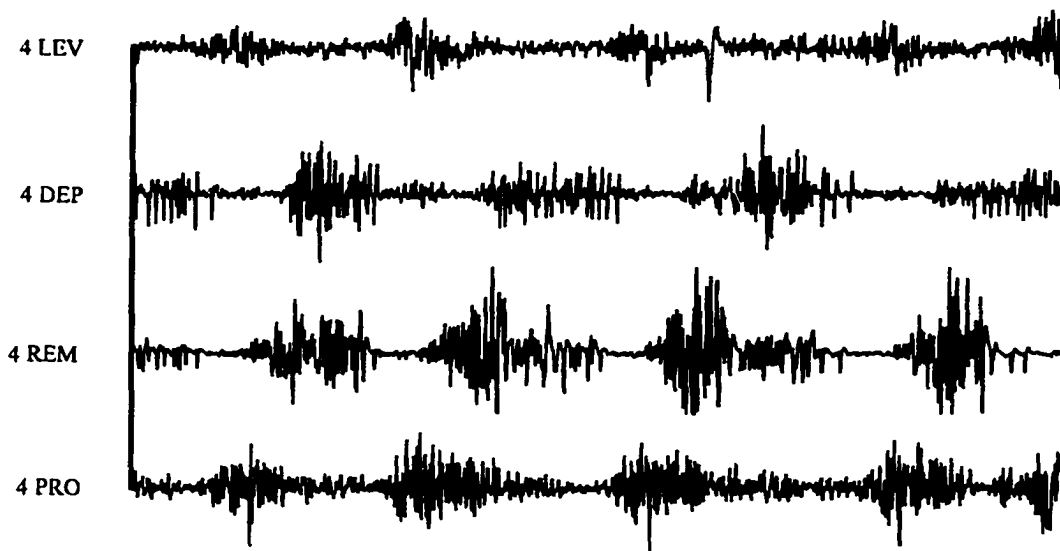
250 ms

Figure 3.17: EMGs of leg 4 proximal muscles in *B. occidentalis* and *E. analoga*

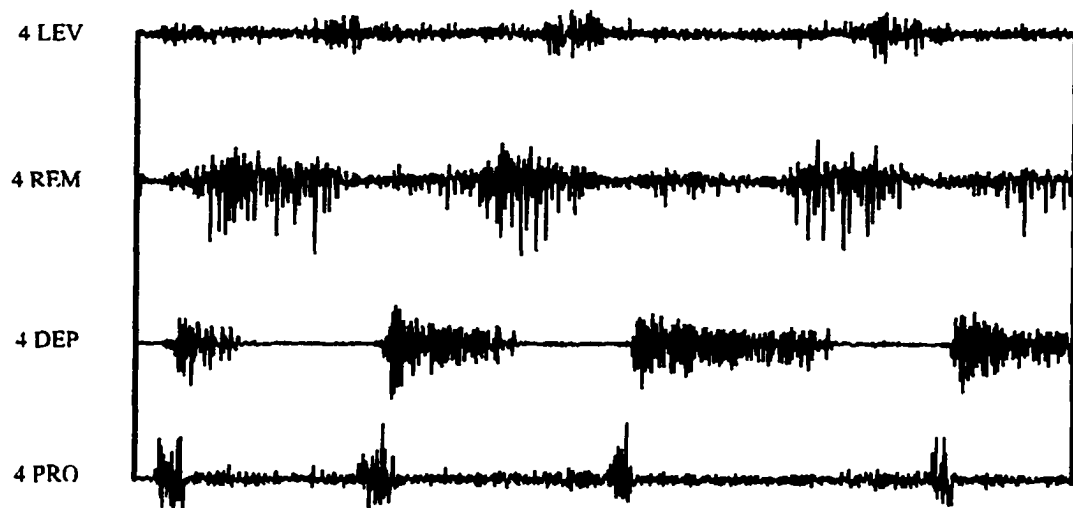
Leg 4 proximal muscle EMGs in (A) *B. occidentalis* and (B) *E. analoga*. EMGs listed in same order as Figure 3.16 (i.e., not proximal to distal). The order of EMG onset is similar to forward walking, unlike leg 2 (Figure 3.16), which resembles backward walking.



(A)



(B)



250 ms

Figure 3.18: Phase histograms of leg 2 proximal muscles in *B. occidentalis* and *E. analoga*

Phase histograms of leg 2 proximal muscle EMGs are left skewed in both (A-D) *B. occidentalis* and (E-H) *E. analoga*. Phase histograms of (A, E) remoter onset in levator period, (B, F) depressor onset in remotor period, (C, G) promotor onset in depressor period, (D, H) levator onset in promotor period. n = (A) 24 digs by four animals, (B) 42 digs by six animals, (C) 18 digs by two animals, (D) 21 digs by three animals, (E) 17 digs by four animals, (F) 18 digs by four animals, (G) 17 digs by four animals, (H) 19 digs by five animals.

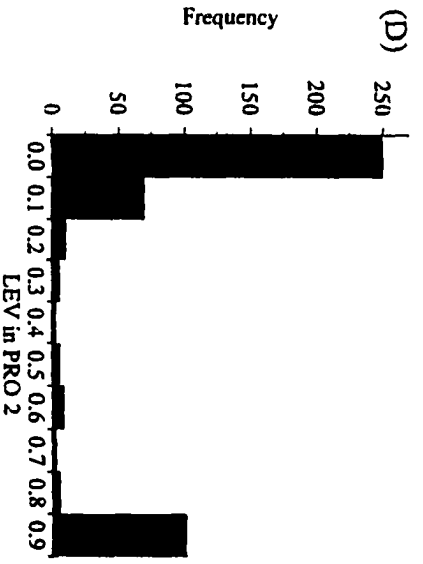
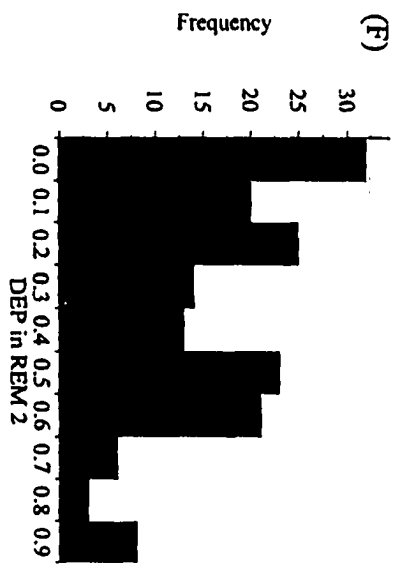
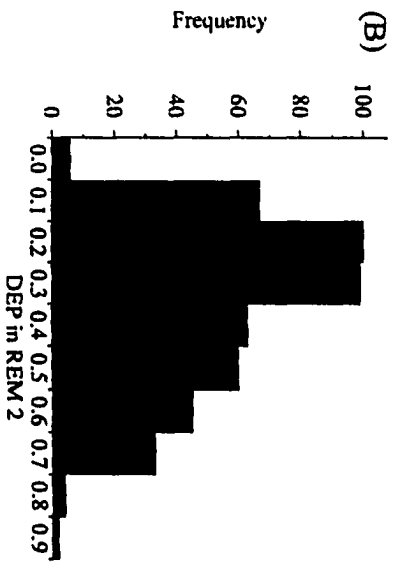
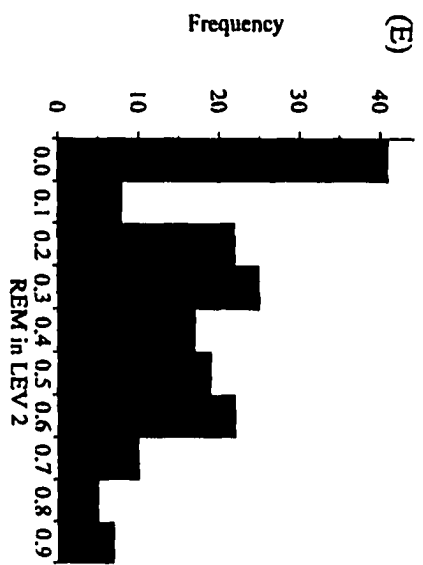


Figure 3.19: Phase histograms of leg 2 proximal muscles in *B. occidentalis* and *E. analoga*. Phase histograms of leg 4 proximal muscle EMGs are mainly right skewed in (A-D) *B. occidentalis* and (E-H) *E. analoga*. Phase histograms of (A, E) remoter onset in levator period, (B, F) depressor onset in remotor period, (C, G) promotor onset in depressor period, (D, H) levator onset in promotor period. The wider distribution of *E. analoga* data is probably due in part to methodological difficulties rather than biological differences (see Methods). n = (A) 16 digs by three animals, (B) 30 digs by six animals, (C) 38 digs by seven animals, (D) 22 digs by four animals, (E) 14 digs by three animals, (F) 18 digs by three animals, (G) 17 digs by three animals, (H) 12 digs by three animals.

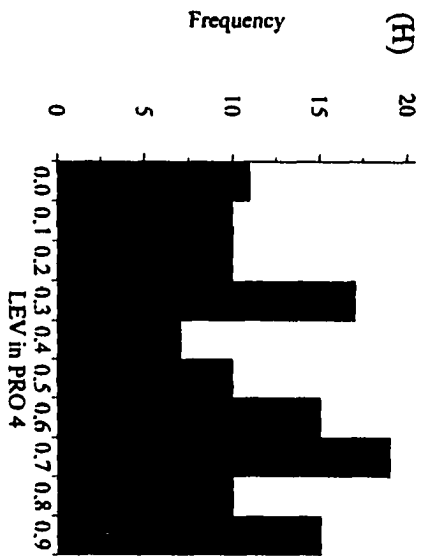
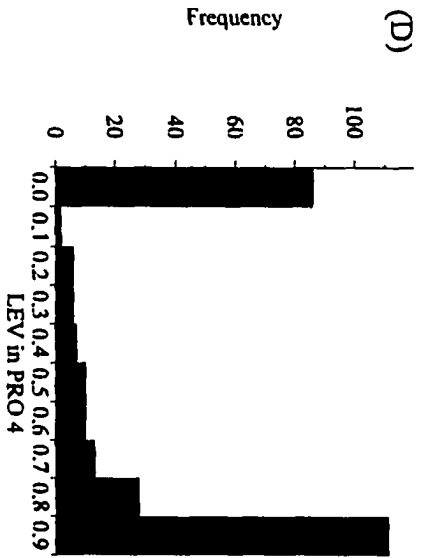
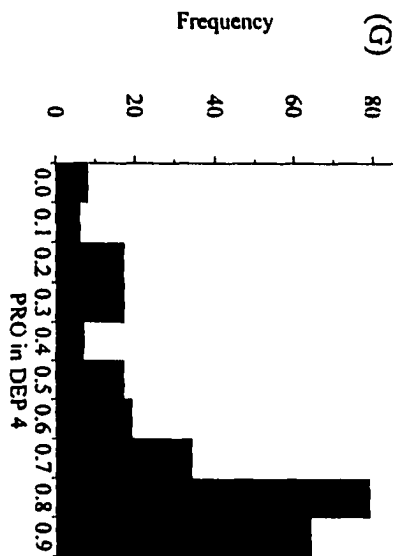
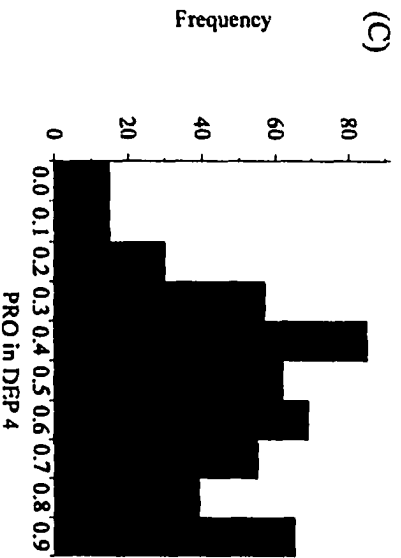
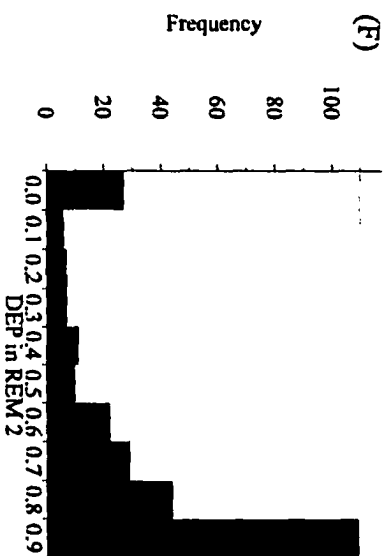
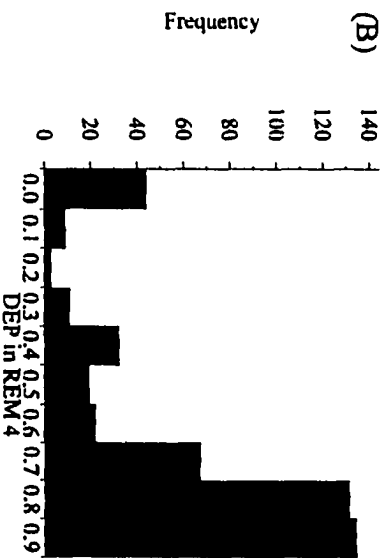
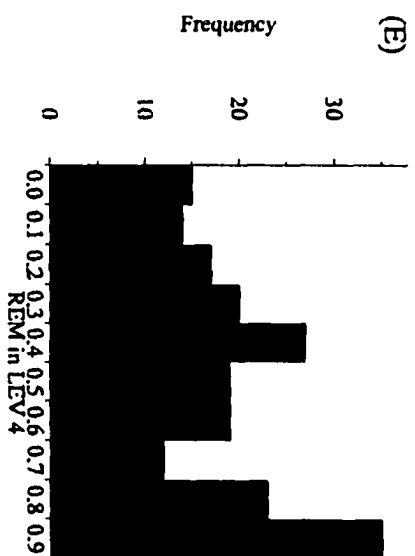
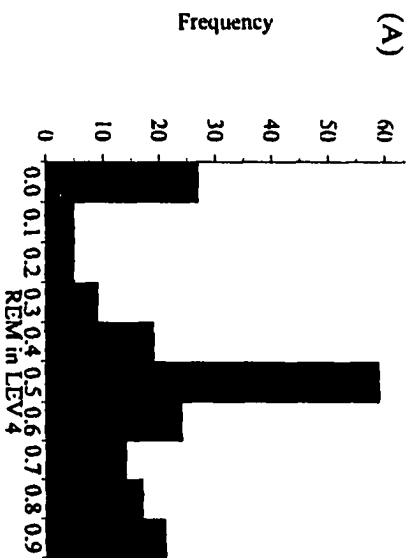


Figure 3.20: Phase/period plots of leg 2 proximal muscles in *B. occidentalis* and *E. analoga*

Phase/period plots of leg 2 proximal muscle EMGs in (A-D) *B. occidentalis* and (E-H) *E. analoga*. Phase/period plots of (A, E) remoter onset in levator period, (B, F) depressor onset in remotor period, (C, G) promotor onset in depressor period, (D, H) levator onset in promotor period. Outliers (period > 2 s) removed. n = (a) 24 digs by four animals, (b) 42 digs by six animals, (c) 18 digs by two animals, (d) 21 digs by three animals, (E) 17 digs by four animals, (F) 18 digs by four animals, (G) 17 digs by four animals, (H) 19 digs by five animals.

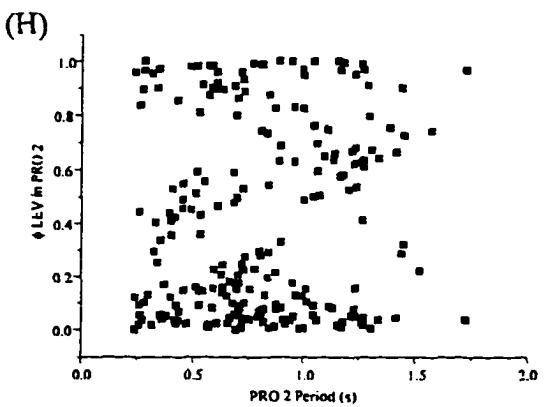
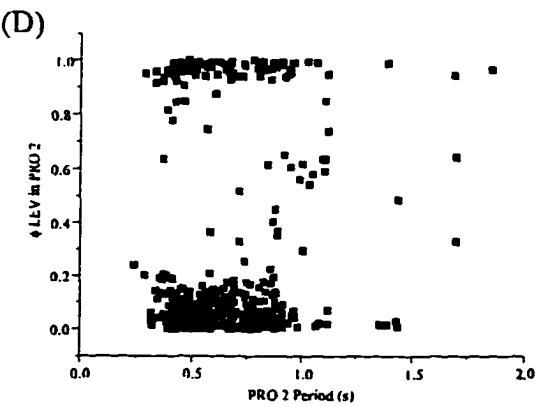
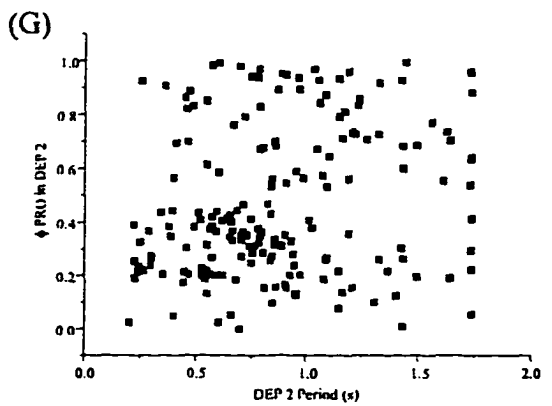
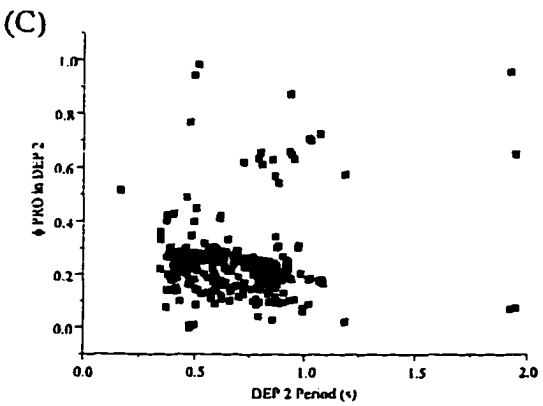
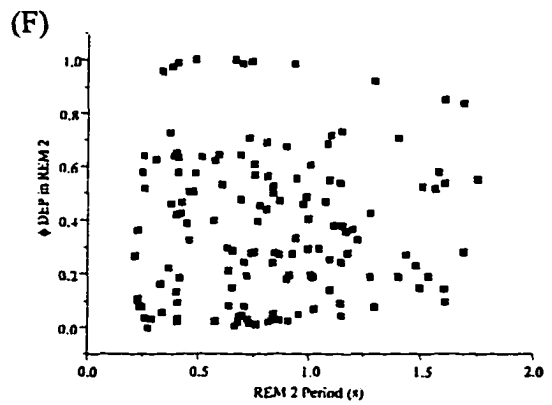
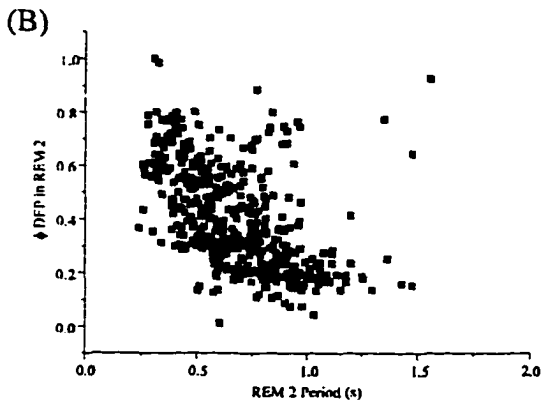
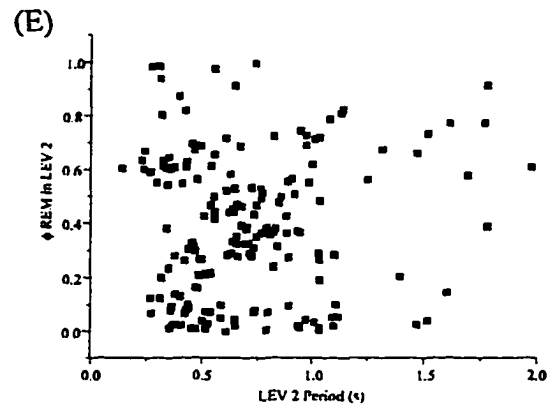
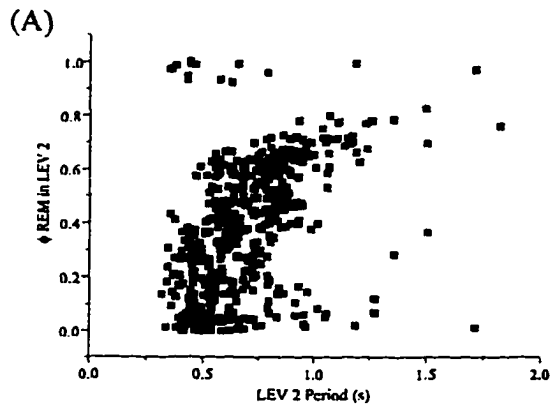
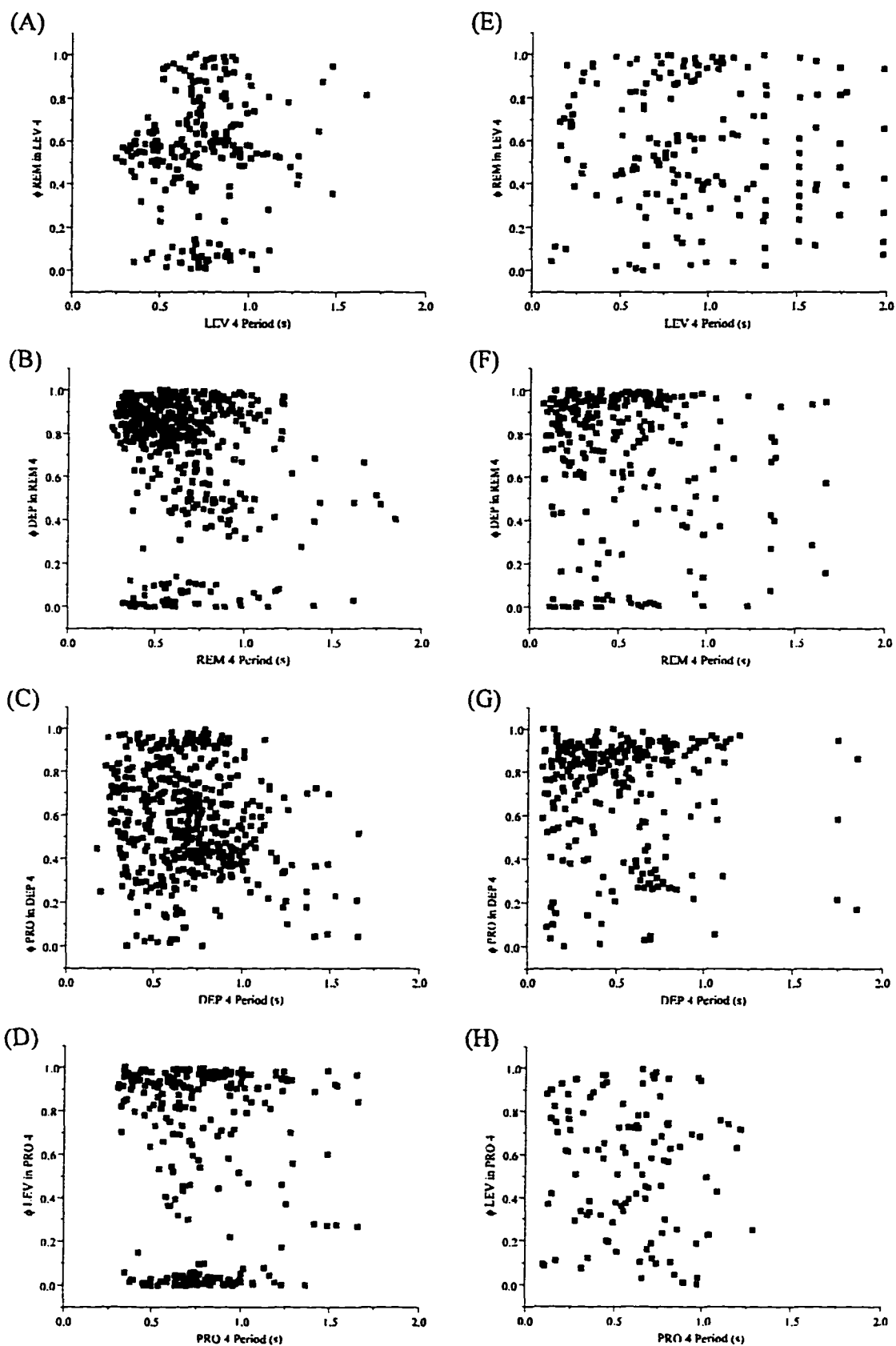


Figure 3.21: Phase/period plots of leg 4 proximal muscles in *B. occidentalis* and *E. analoga*

Phase/period plots of leg 4 proximal muscle EMGs in (A-D) *B. occidentalis* and (E-H) *E. analoga*. (A, E) Remoter onset phase in levator period, (B, F) depressor onset phase in remoter period, (C, G) promotor onset phase in depressor period, (D, H) levator onset phase in promotor period. The difficulty in recording EMGs from leg 4 lowers my confidence in the *E. analoga* data, particularly those involving the levator (*E, H*). Outliers (period > 2 s) removed. n = (A) 16 digs by three animals, (B) 30 digs by six animals, (C) 38 digs by seven animals, (D) 22 digs by four animals, (E) 14 digs by three animals, (F) 18 digs by three animals, (G) 17 digs by three animals, (H) 12 digs by three animals.



EMG burst and period

The motor output of single legs differs when an individual is making digging movements above sand and during digging in sand. When *B. occidentalis* is in water, the motor output of legs 2 and 3 is sinusoidal: the amplitude of the leg movements is inversely proportional to the period (Figure 3.22), as are both the frequency and amplitude of EMG potentials (e.g., Figure 3.27A, B). Leg 4 shows no clear correlation between amplitude of its movements (and the concomitant EMG bursts) and the period of leg movements (Chapter 2, Interleg coordination, Tip trajectories: 21). In legs 2 and 3, both power and return strokes increase with period (Figure 3.22A, B). Such increases in the duration of whole leg movements could be due to the bursts in different muscles becoming less synchronous, or to EMG bursts of individual muscles lengthening, or a combination of the two. Electromyograms from the closer suggest that decreased synchrony between bursts alone is not responsible for the increased duration of the return stroke, because the closer EMG burst durations tend to increase with period when an animal is above sand (Figure 3.22C), which is not the case when animal is actually digging (Figure 3.23E).

When individuals dig, the EMGs from leg 2 show that the burst durations of power stroke muscles increase with period ($r > 0.7$; Figure 3.23), whereas the burst durations of return stroke muscles increase only very weakly as period increases ($r < 0.5$; Figure 3.23). The EMGs from leg 4, however, do not show such straightforward relationships between burst duration and period: almost all r values are intermediate to those calculated for the muscles in leg 2 (Table 3.3, Table 3.4). This supports my interpretation of the movement analysis, where there is no straightforward division of the leg 4 movement into power and return stroke components.

Figure 3.22: Sinusoidal leg 2 movements above sand in *B. occidentalis*

(A) Horizontal amplitude of forward and backward movement of leg 2 during a long bout of “digging” movements above sand; the most vigorous movements occurred at the start of the sequence. The leg movement amplitude decreased with frequency. Higher values on *Y* axis indicate the leg in a more anterior position than lower *Y* values. (B) Duration of power and return stroke compared to period. Both lengthen with period, although the return stroke shows a higher correlation with period than the power stroke. Same data as *A*. (C) Duration of leg 2 closer EMG burst compared to period when animal is above sand. Closer burst length increases with period when animals are swimming ($r = 0.65673$), but during actual digging, closer burst length does not increase with period ($r < 0.2$; Figure 3.23*E*). Sample size: $n =$ ten digs by four animals.

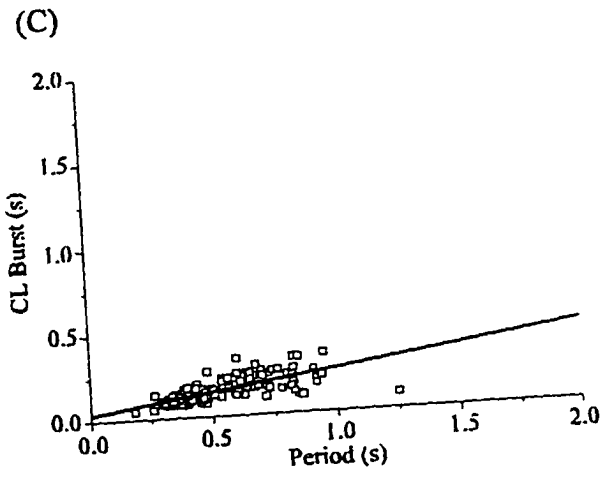
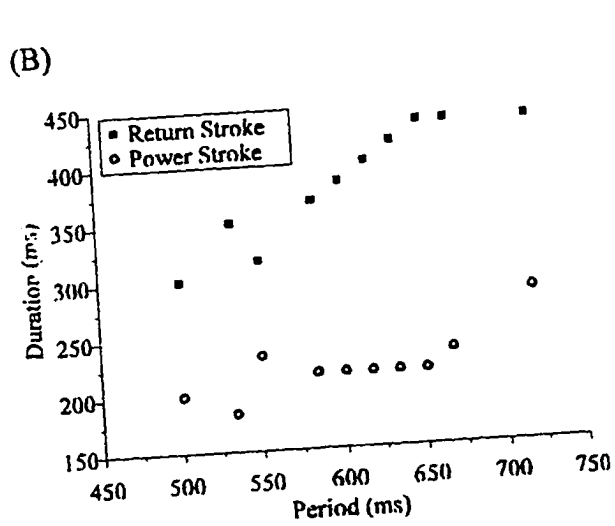
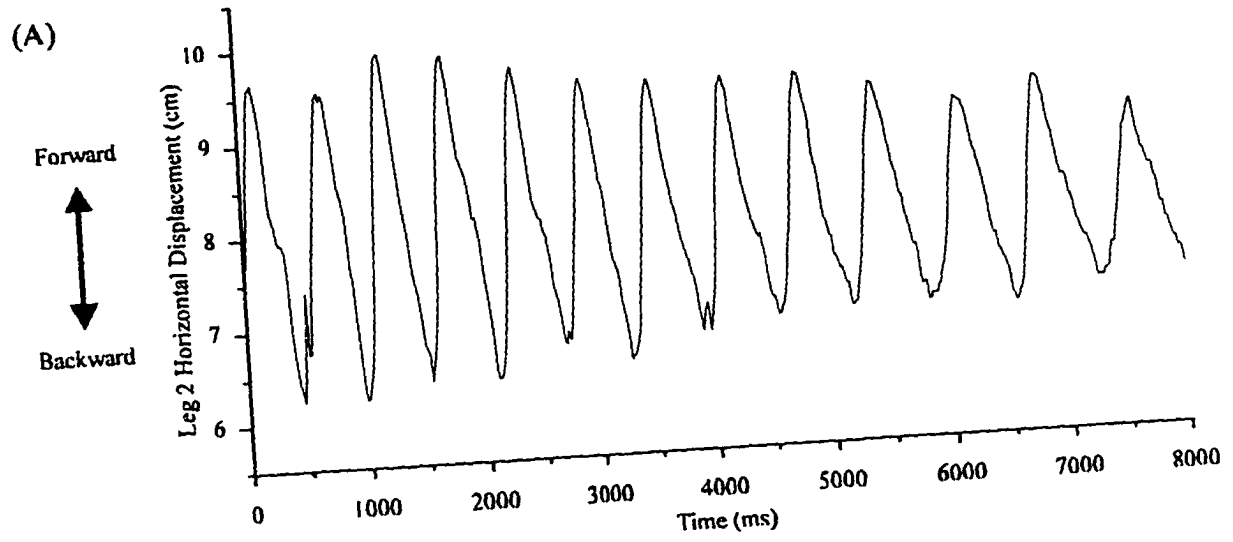
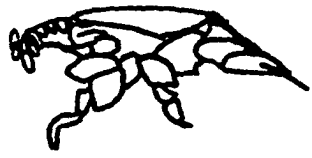


Table 3.3: Regression values of EMG burst durations and period in *B. occidentalis*

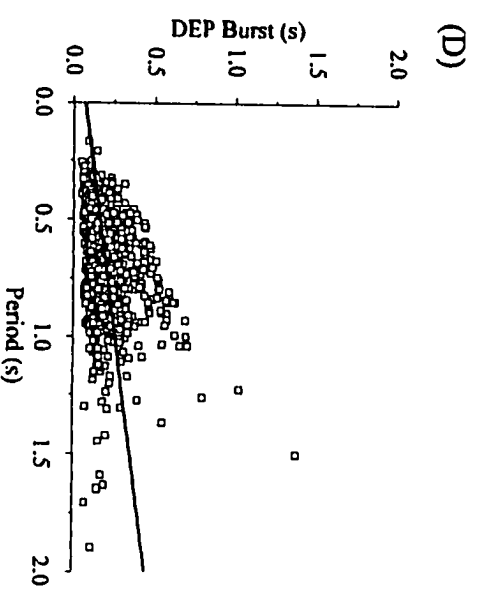
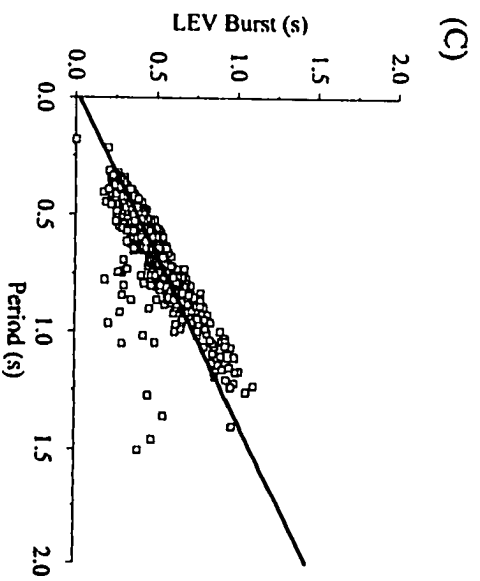
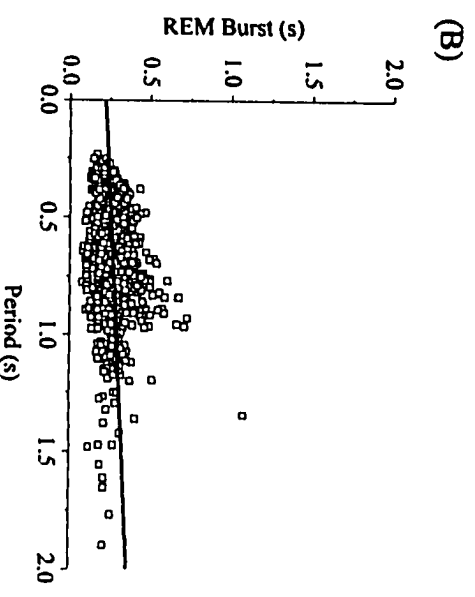
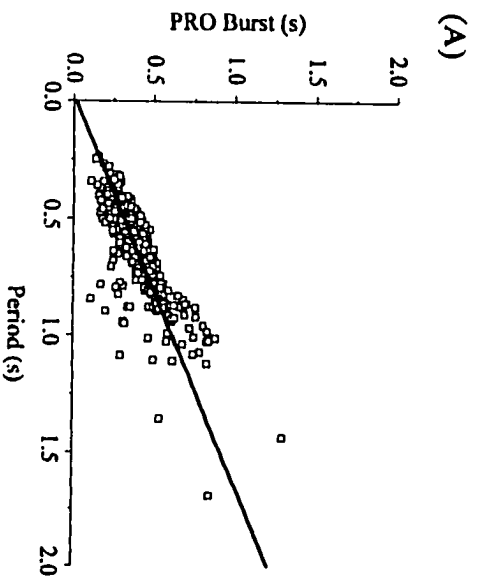
Leg 2: For all power stroke muscles (bold), $r > 0.7$, whereas for all return stroke muscles (plain), $r < 0.5$. *Leg 4*: The r values for leg 4 are intermediate to those calculated for leg 2 muscles (i.e., $0.5 < r < 0.7$) except for the promotor and remoter. The unpaired reductor muscle has no antagonist, but functions as a power stroke synergist (Figure 3.5, Figure 3.8). The stretcher and opener are indicated in italics because their bursts are identical, although their movements are not (Opener and stretcher EMGs: 148). Same data as for Figure 3.23 to Figure 3.24. Outliers (period > 2 s) removed before regression calculated.

Table 3.3

Muscle	Leg	r	SD	# Digs	# Animals	# Strokes
PRO	Leg 2	0.80506	0.09154	21	4	344
	Leg 4	0.49102	0.13066	48	7	616
REM	Leg 2	0.18161	0.09637	44	10	741
	Leg 4	0.75533	0.12656	27	5	436
LEV	Leg 2	0.84683	0.09184	31	5	591
	Leg 4	0.67685	0.09184	27	4	375
DEP	Leg 2	0.35146	0.11898	32	6	821
	Leg 4	0.6624	0.1185	113	11	1625
RED	Leg 2	0.93102	0.05619	5	1	97
	Leg 4	0.6834	0.1101	20	4	465
EXT	Leg 2	0.77083	0.11041	35	4	643
	Leg 4	0.52059	0.13037	61	10	842
FLX	Leg 2	0.45906	0.1152	14	4	199
	Leg 4	0.52183	0.0748	16	2	250
BND	Leg 2	0.92688	0.08303	26	4	464
	Leg 4	0.63972	0.1349	28	4	460
CL	Leg 2	0.20497	0.07086	52	8	1077
	Leg 4	0.57294	0.09305	71	11	1099
<i>OP 2</i>	Leg 2	0.72573	0.10883	25	4	372
<i>STR 4</i>	Leg 4	0.68343	0.11005	31	5	465

Figure 3.23: Leg 2 burst/period plots for *B. occidentalis*

Burst/period scatter plots for (A) promotor, (B) remoter, (C) levator, (D) depressor, (E) reductor, (F) extensor, (G) flexor, (H) bender, (I) closer, and (J) opener in leg 2 of *B. occidentalis*. Outliers (data with periods > 2 s) removed before regression line calculated. Regression values shown in Table 3.3.



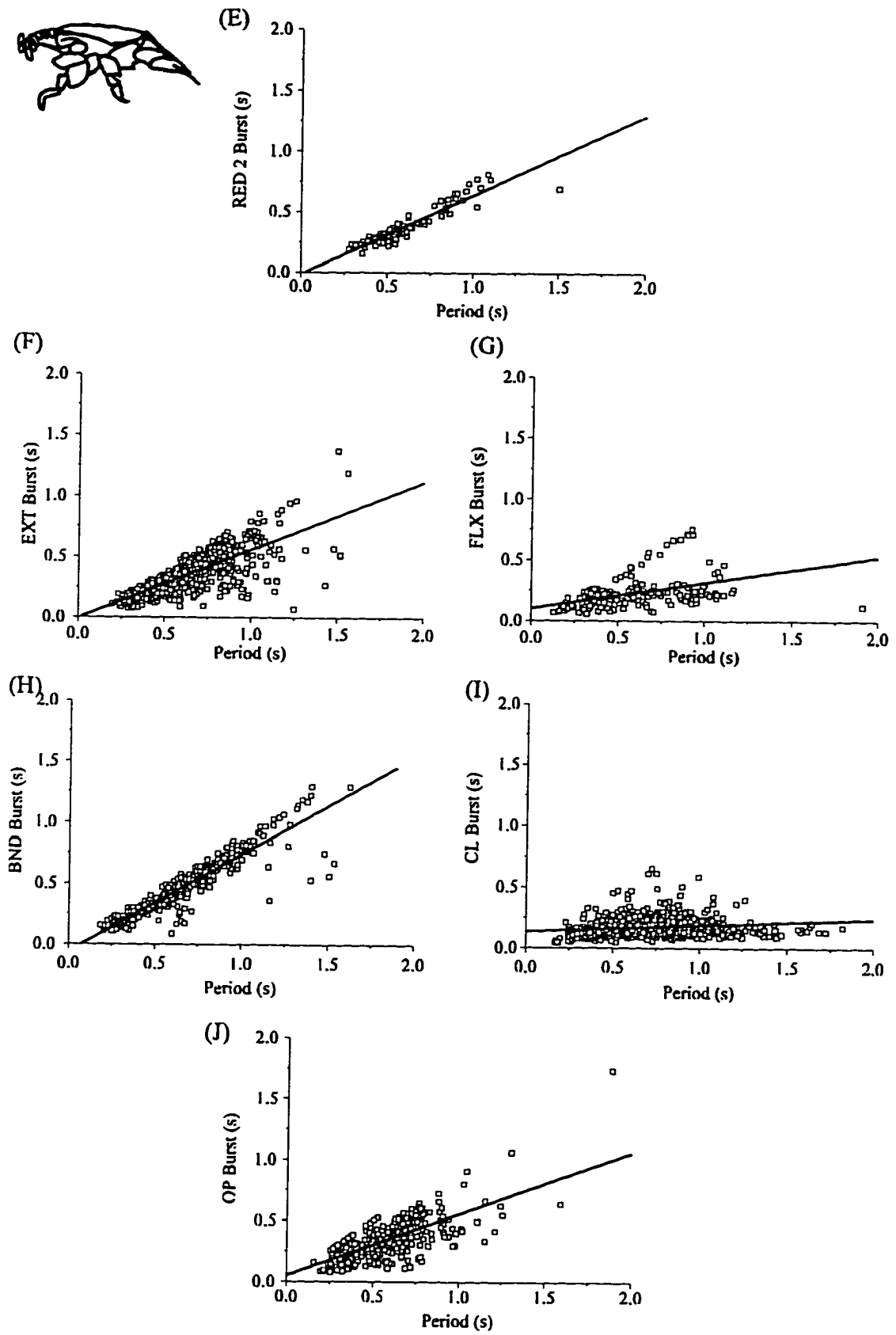
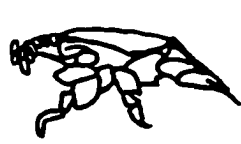
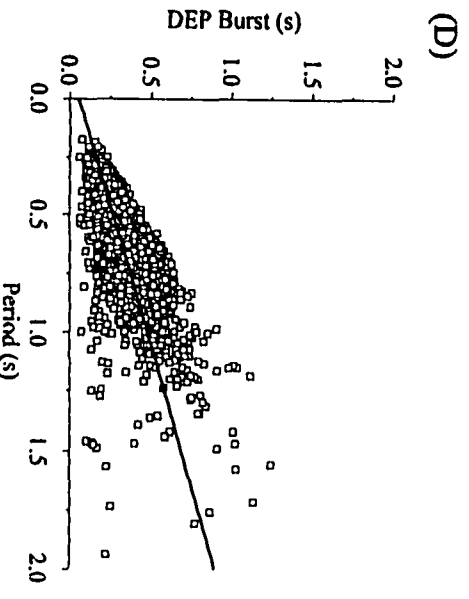
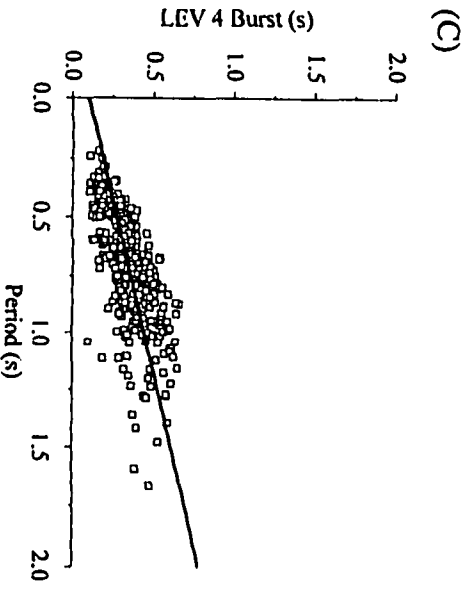
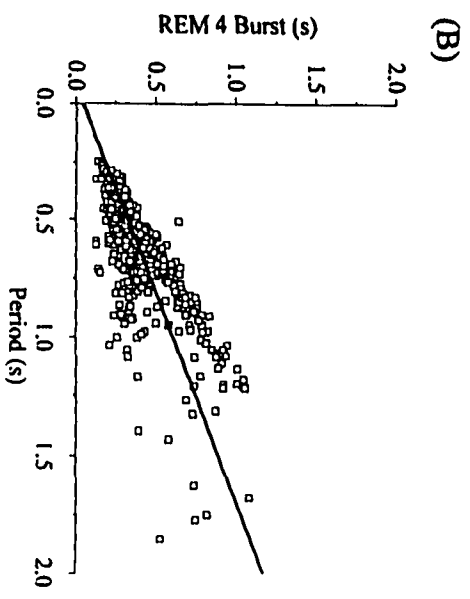
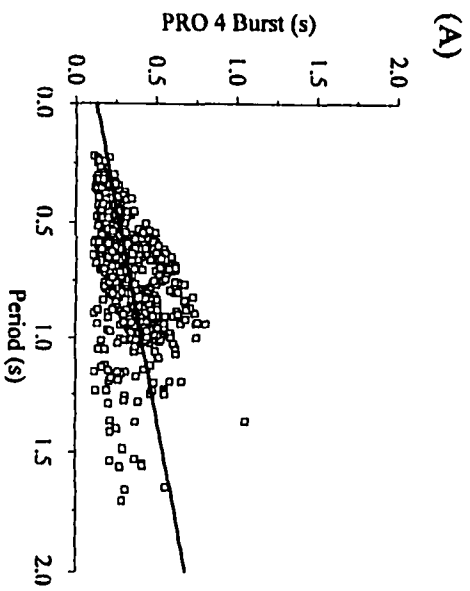


Figure 3.24: Leg 4 burst/period plots for *B. occidentalis*

Burst/period scatter plots (A) levator, (B) depressor, (C) promotor, (D) remotor, (E) reductor, (F) extensor, (G) flexor, (H) bender, (I) closer, and (J) stretcher in leg 4 of *B. occidentalis*. Outliers (data with periods > 2 s) removed before regression line calculated. Regression values shown in Table 3.3.



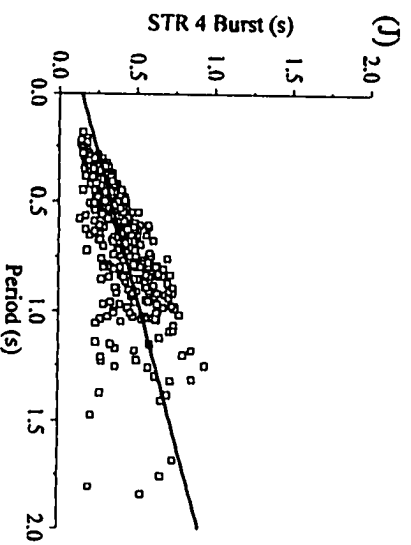
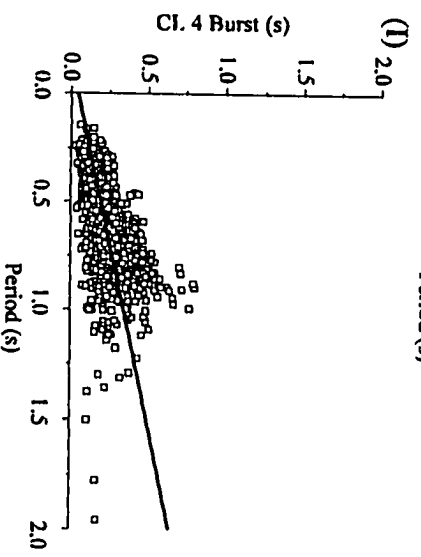
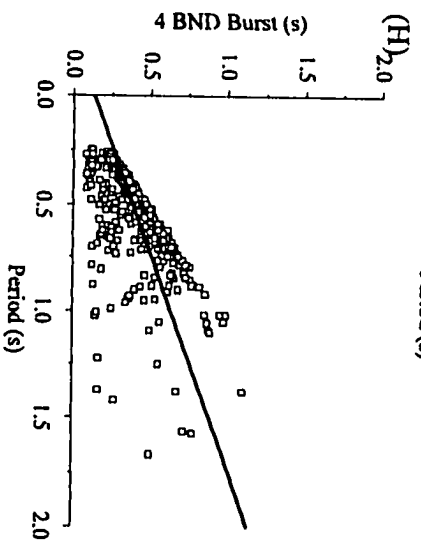
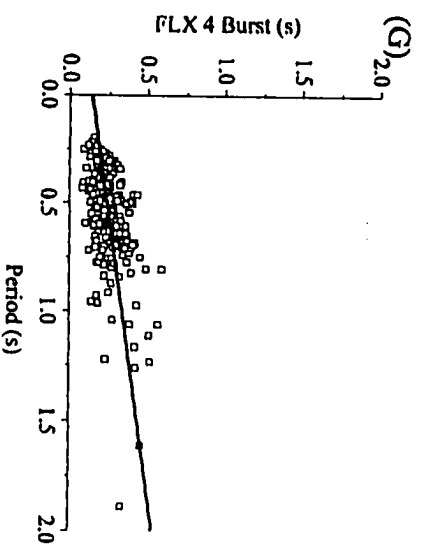
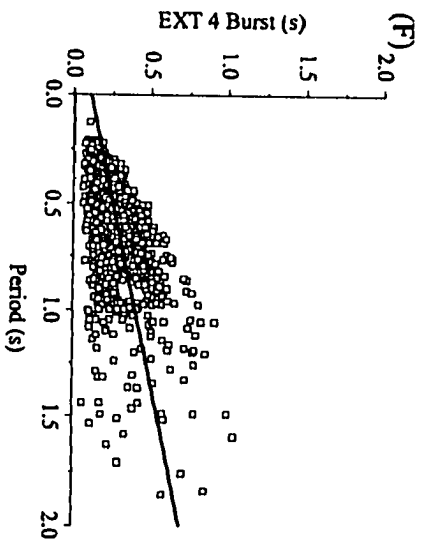
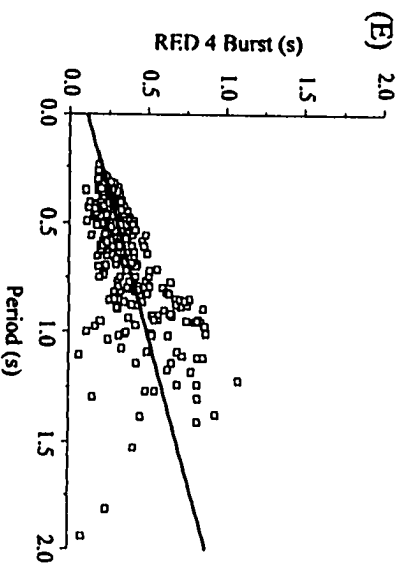


Table 3.4: Regression values of EMG burst durations and period in *E. analoga*

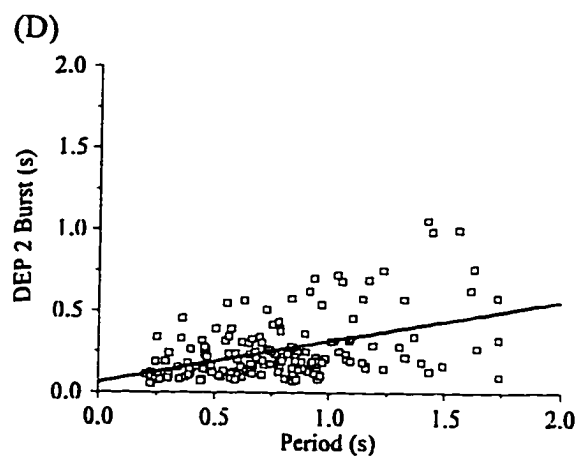
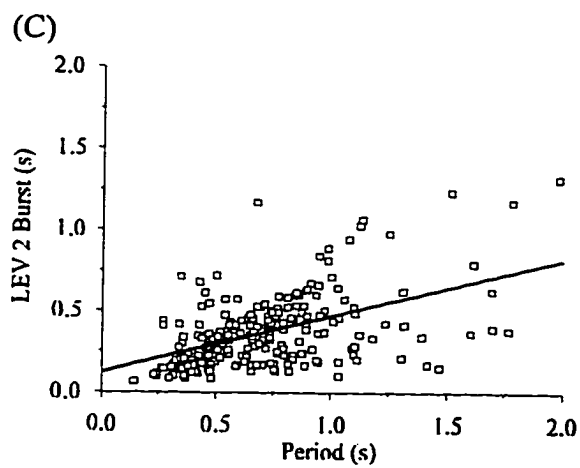
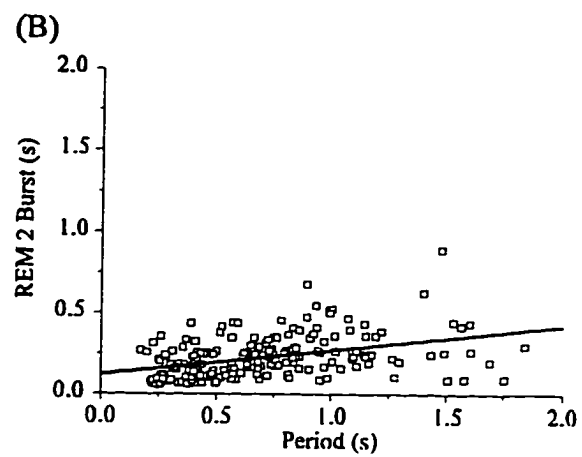
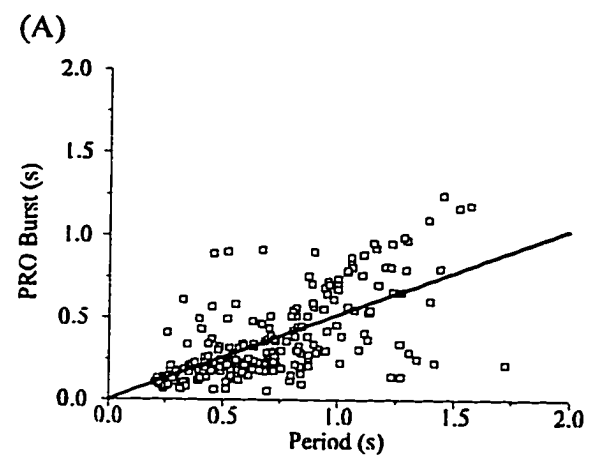
Leg 2: Calculated regression values are higher for the power stroke muscles (**bold**) than the return stroke muscles (**plain**) except for the extensor and flexor; in that case, the flexor burst was successfully recorded from only one animal due to the difficulty of placing electrodes. Same data as Figure 3.25 and Figure 3.26. *Leg 4*: The r values for the promotor and remotor leg 4 leg are reversed relative to leg 2, as they are in *B. occidentalis*. The unpaired reductor is a power stroke synergist (Figure 3.8). The opener and stretcher bursts are identical, but the movements produced are not synergists (Opener and stretcher EMGs: 148), so these muscles are indicated in italics. Same data as Figure 3.26. Outliers (period > 2 s) removed before regression calculated.

Table 3.4

Muscle	Leg	r	SD	# Digs	# Animals	# Strokes
PRO	Leg 2	0.65857	0.19513	19	5	212
	Leg 4	0.49262	0.11658	17	2	268
REM	Leg 2	0.42104	0.11875	18	4	195
	Leg 4	0.65711	0.14096	18	2	283
LEV	Leg 2	0.50895	0.193	20	5	216
	Leg 4	0.64789	0.12281	15	2	115
DEP	Leg 2	0.46917	0.16744	18	4	163
	Leg 4	0.61004	0.11211	18	2	288
RED	Leg 2	0.52759	0.17922	10	2	100
	Leg 4	—	—	—	—	—
EXT	Leg 2	0.56278	0.24719	37	5	358
	Leg 4	—	—	—	—	—
FLX	Leg 2	0.65277	0.0344	6	1	62
	Leg 4	—	—	—	—	—
BND	Leg 2	0.82528	0.14178	62	7	627
	Leg 4	0.80605	0.2083	15	3	131
CL	Leg 2	0.29433	0.12154	36	7	338
	Leg 4	0.74204	0.12711	18	4	239
OP 2	Leg 2	0.81183	0.05813	25	4	313
STR 4	Leg 4	0.94056	0.08836	38	6	498

Figure 3.25: Leg 2 burst/period plots for *E. analoga*

Burst/period scatter plots of (A) promotor, (B) remotor, (C) levator, (D) depressor, (E) reductor, (F) extensor, (G) flexor, (H) bender, (I) closer, and (J) opener in leg 2 EMGs of *E. analoga*. Outliers (data with periods > 2 s) removed before regression line calculated. Regression values shown in Table 3.4.



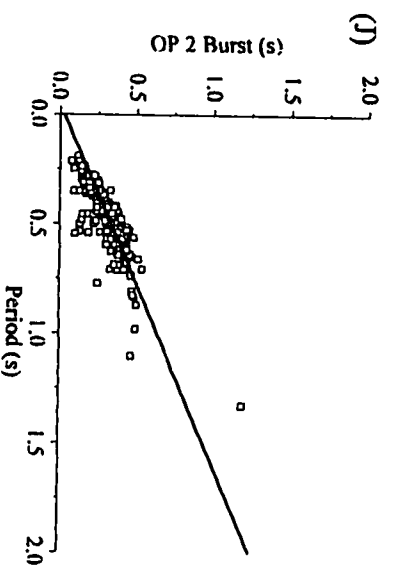
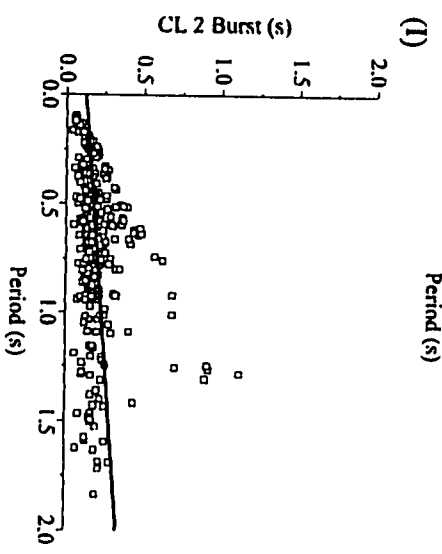
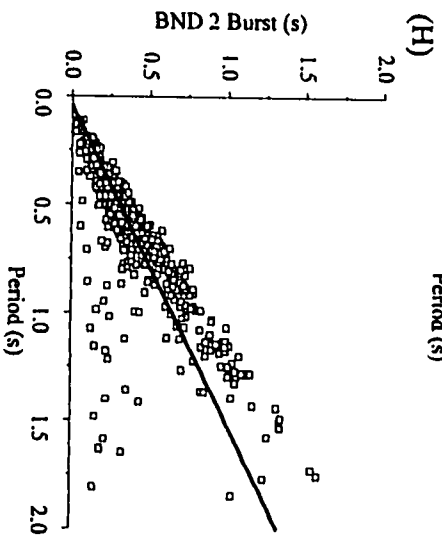
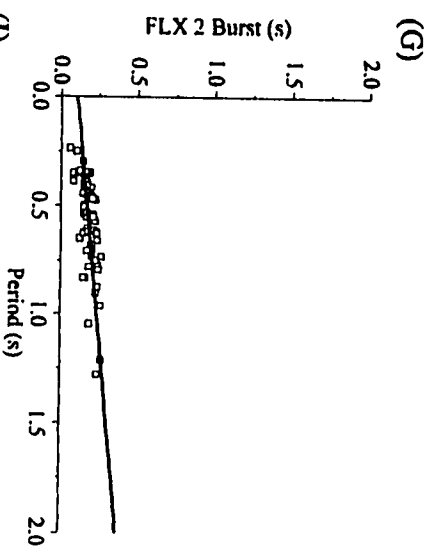
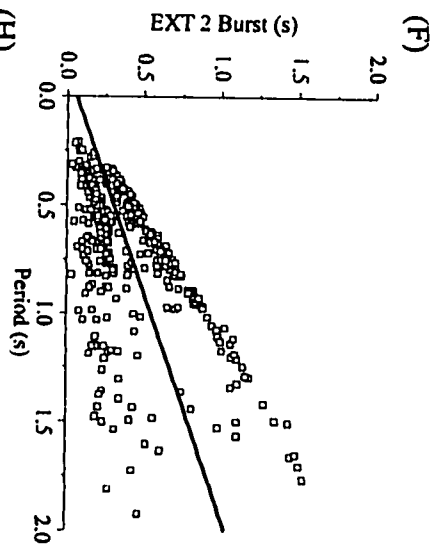
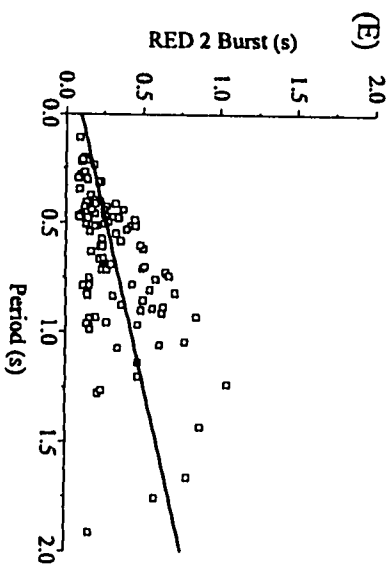
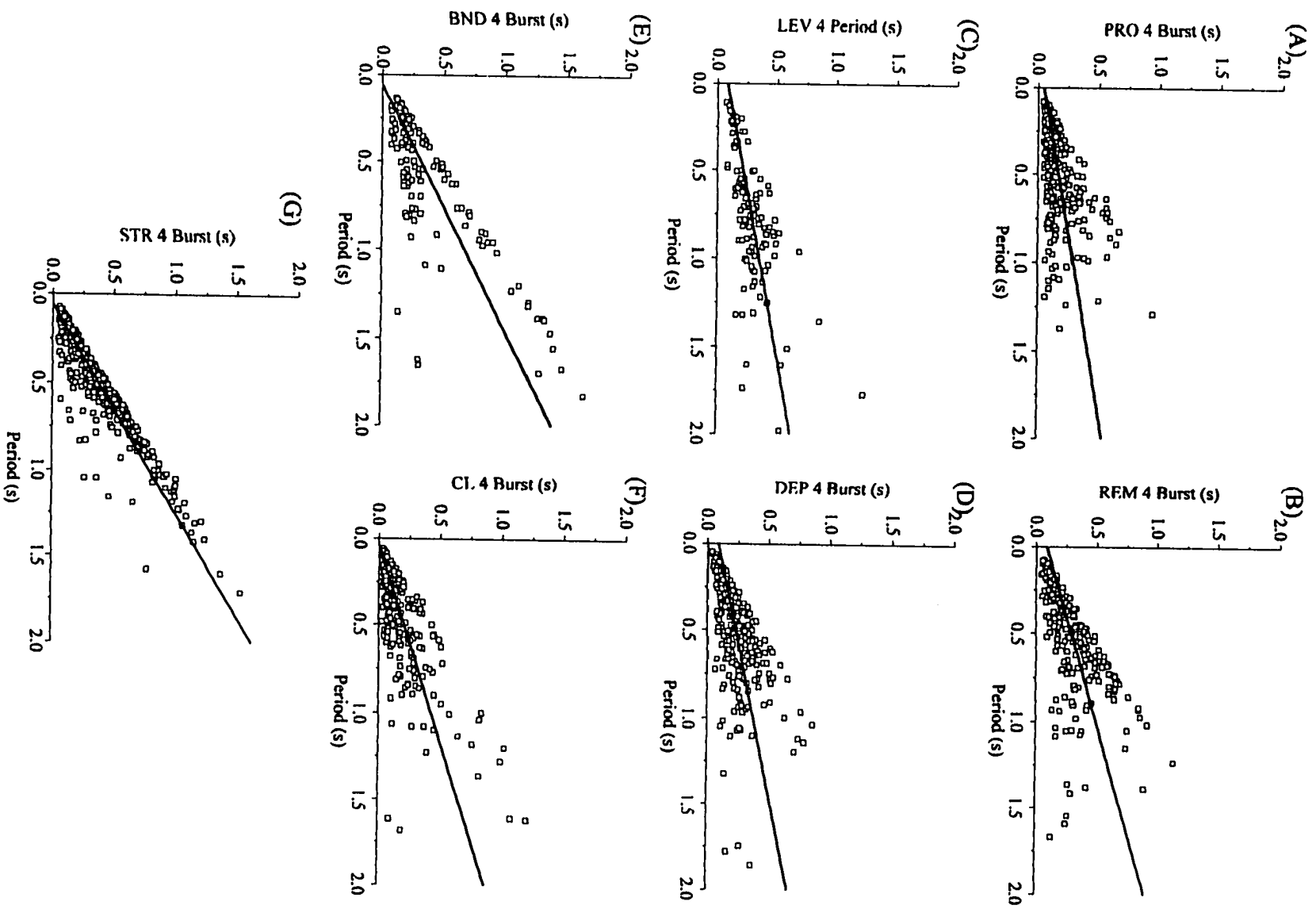


Figure 3.26: Leg 4 burst/period plots for *E. analoga*

Burst/period plots (A) promotor, (B) remoter, (C) levator, (D) depressor, (E) bender, (F) closer, and (G) stretcher in leg 4 of *E. analoga*. Outliers (data with periods > 2 s) removed before regression line calculated. Regression values shown in Table 3.4.



Opener and stretcher EMGs

In the reptantian species that have been closely examined, the opener and stretcher muscles are innervated by only one excitatory motor neuron that is shared between them (OE≡SE). This unusual innervation pattern has no known functional advantage over separate excitatory innervation. The muscles can move independently, however, because each one is also innervated by a specific inhibitory motor neuron, the opener inhibitor (OI) and stretcher inhibitor (SI) [reviewed in Wiens 1989; see also Chapter 6, Distal leg motor neurons: 187].

Due to the co-excitation of the opener and stretcher, EMGs bursts from these muscles condure, and match potential for potential [Atwood & Walcott 1965; Clarac et al. 1987]. Individual EMG potentials are not perfectly synchronous (Figure 3.27): the stretcher potentials precede the opener's by ~1.5 ms in *B. occidentalis* and ~1 ms in *E. analoga*. In comparison, the stretcher precedes the opener by ~3 ms in walking shore crabs (*Carcinus maenas*) [Clarac et al. 1987]. These differences in the delay of the EMG potentials are probably due to the shorter conduction distance from the ganglion to the opener and stretcher muscles in sand crab leg segments compared to corresponding leg segments in shore crabs (*C. maenas*: 80 mm carapace width, 60 g; *B. occidentalis*: ~40 mm carapace length, ~30 g wet weight; *E. analoga*: ~25 mm carapace length, ~10 g wet weight). In contrast, the movements generated by the opener and stretcher are not synchronous: in fact, they generally do not overlap at all in *B. occidentalis*, with the stretcher movement preventing the opener's in leg 2 (Figure 3.4). In leg 2, the stretcher-generated movement pridures the opener/stretcher EMG, and is a robust movement contributing to the return stroke. The opener-generated movement postdures the opener/stretcher EMG and is an important component of the power stroke. To my knowledge, this is the first time that these muscles have been shown to generate temporally distinct, large amplitude movements at their respective joints during rhythmic behaviour.

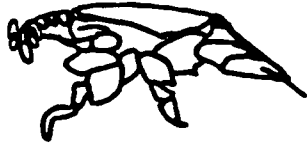
There are several factors that could explain why the movement and the muscle activity do not coincide. In forward walking crayfish [Barnes 1977], the propus-dactyl joint is held still because the closer muscle is active at the same time as the opener, and only the stretcher (and its antagonist, the bender) generates movement at the carpus-propus joint. Coactivation of antagonistic muscles also occurs in *B. occidentalis* (Figure 3.28; see also movement analyses in Figure 3.10, Figure 3.11, Figure 3.12), and may explain the temporal separation of opening and stretching movement, if one assumes that the closer and bender contractions are strong enough to overpower the tension generated by the stretcher and opener. In some cases, however, the movements generated by the bender and closer muscles do not overlap with the opener and stretcher movements (e.g., Figure 3.8, Figure 3.9), nor do the antagonistic EMGs have sufficient overlap (Figure 3.28B) to make antagonistic muscle activity the sole explanation for the difference between EMGs and movement. Thus, it seems likely that peripheral inhibition plays some role in allowing the independent movement of the two joints. In leg 2, the amplitudes of the stretcher potentials are often larger during the first half of the burst, while the opener potentials tend to be larger in the second half of the burst, corresponding to when the two muscles are generating their respective movements, suggesting that inhibitory motor neuron activity may be influencing the amplitude of EMG potentials. In crustaceans, peripheral inhibition can be exerted either post- or pre-synaptically [Atwood 1977], and both mechanisms can operate concurrently in decapod legs [Spirito 1970]. The long trains of matching potentials in opener and stretcher EMGs indicate that pre-synaptic inhibition is probably not a significant factor here, because presynaptic inhibition greatly reduces or blocks excitatory neurotransmitter release entirely, when the timing between the action potentials in the inhibitory and excitatory neurons is appropriate [Dudel & Kuffler 1961]; one would expect, therefore, mismatches between the opener and stretcher EMGs were pre-synaptic inhibition occurring.

The combined movement and EMG analyses confirmed that the non-overlapping movements of the propus and dactyl are generated by synchronous EMG bursts, and also revealed a new feature. There is a drop in the frequency of EMG potentials when the

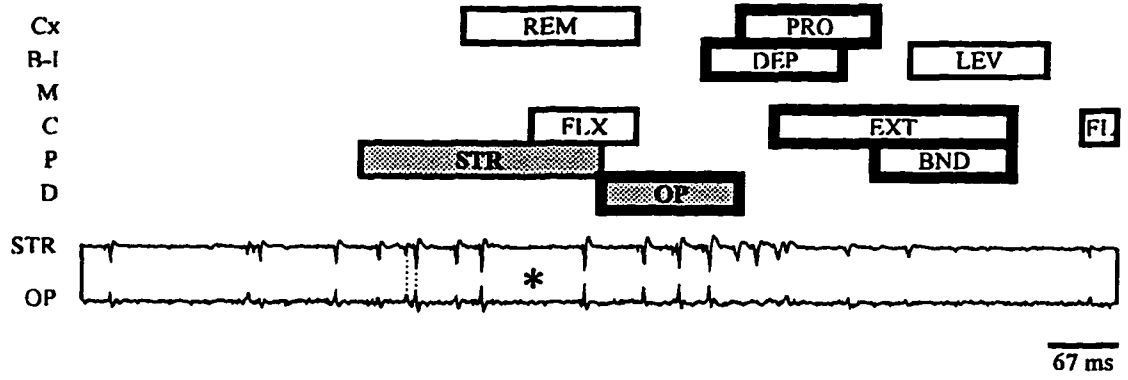
stretcher-generated movement stops and the opener generated movement begins (see Figure 3.12, Figure 3.27, Figure 3.28). At low frequencies (e.g., when an individual is making digging movements above sand), it is reasonable to assume that each EMG potential is correlated with a single action potential of the shared OE≡SE motor neuron, which indicates that this momentary pause in the EMG potentials represents a transient change in the firing of OE≡SE.

Figure 3.27: OP and STR EMGs in *B. occidentalis* and *E. analoga*

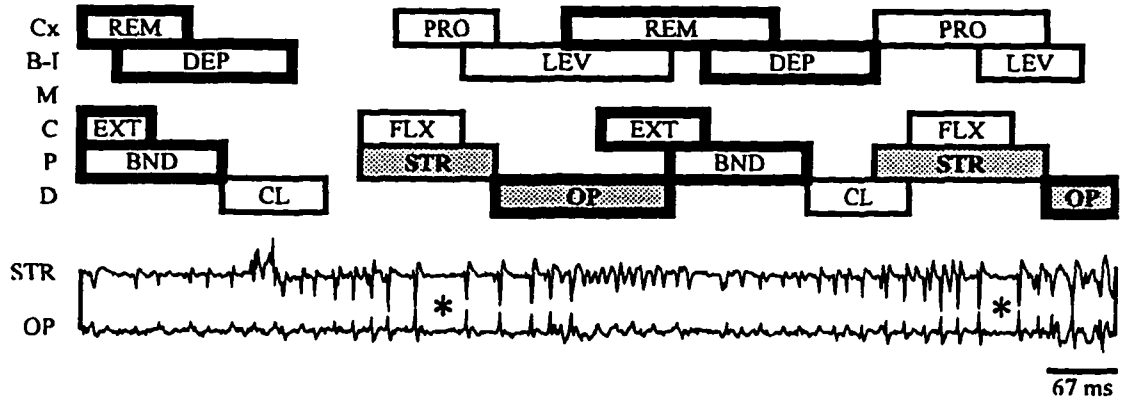
Combined EW/EMG analyses of opener and stretcher muscles in leg 2 of *B. occidentalis*. (A) Simplified EW analysis of video sequence and EMGs recorded simultaneously when *B. occidentalis* was making a small amplitude leg stroke; (B) when the same individual making a larger amplitude leg stroke; (C) EMGs from the same individual actually digging. Same vertical scale in all. Dashed lines in A show pair of potentials with an instantaneous frequency of $> 100\text{Hz}$, showing that potentials in the two records match even at very high frequencies. * = momentary drops in potential frequency at the transition point when the stretcher-generated movement stops and the opener-generated movement begins (see also Figure 3.12, Figure 3.28). Stretcher potentials slightly precede opener potentials in *B. occidentalis* and *E. analoga*. (D-E) Opener and stretcher EMGs in leg 2 of *B. occidentalis*. The stretcher potentials precede the opener potentials by ~ 1.5 ms. (F-G) Opener and stretcher EMGs in leg 2 of *E. analoga* at different sweep speeds. The stretcher potentials occur ~ 1 ms before the opener's. Downward arrows = approximate beginning of stretcher EMG potential; upward arrow = approximate beginning of opener EMG potential; ? = (D) potentials of unknown identity regularly preceding STR, possibly extracellular record of motor neuron firing.



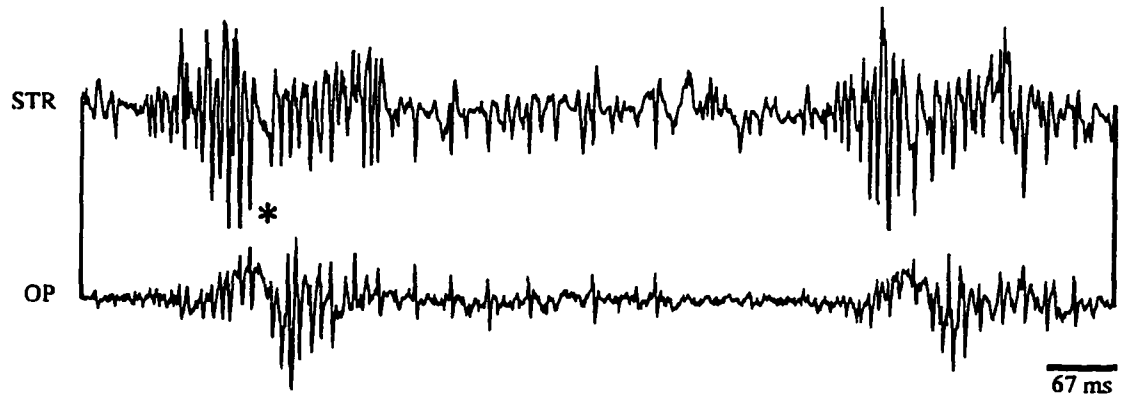
(A)



(B)



(C)



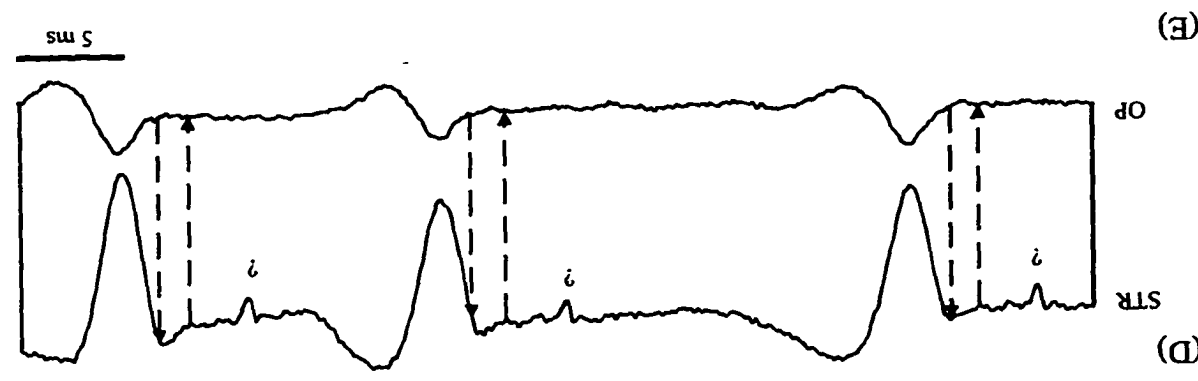
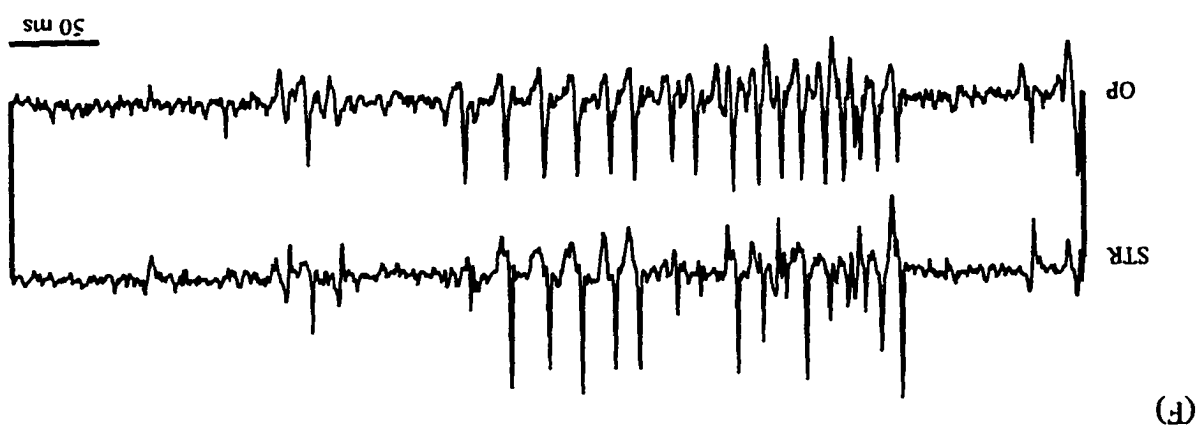
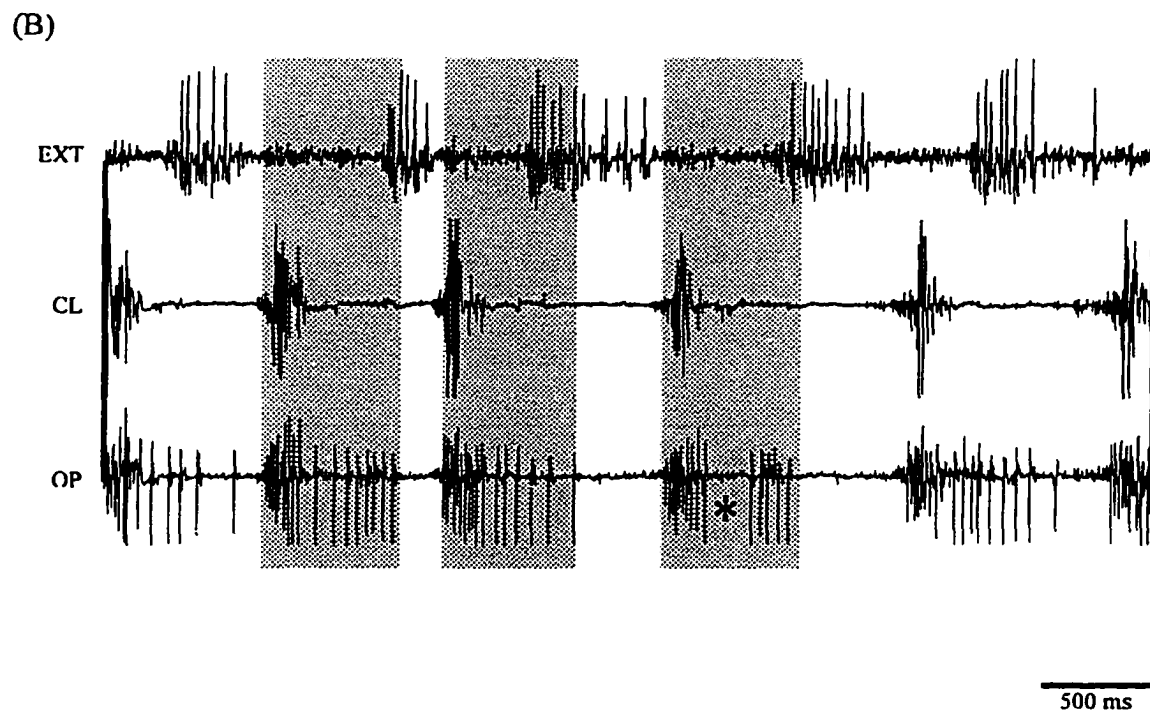
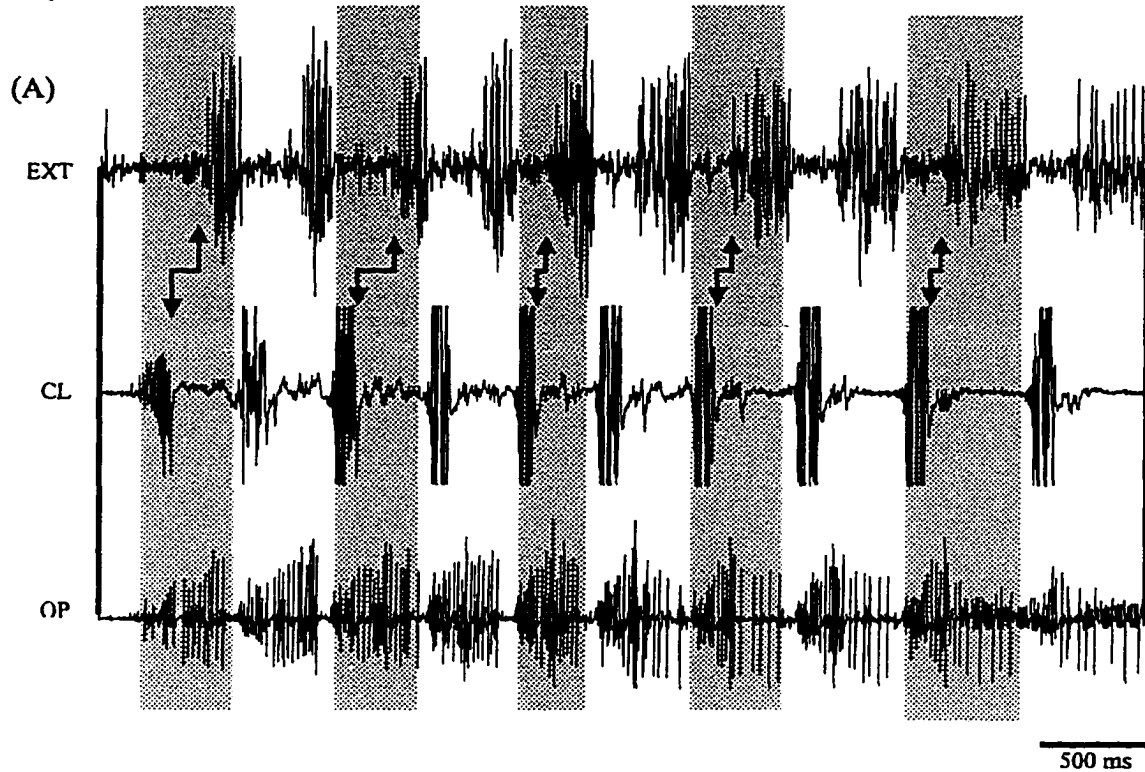


Figure 3.28: Opener antagonists in *B. occidentalis*

Antagonistic muscle activity may partly explain the disjunction of opener- and stretcher generated movement and opener/stretcher EMGs in *B. occidentalis*. (A-B) EMGs of extensor, closer, and opener recorded simultaneously from a long digging sequence; *A* and *B* are not continuous. Although the extensor is not an antagonist to either the opener or stretcher, its bursts are synchronous with those of the bender (Figure 3.10, Figure 3.14), so the extensor EMG can be used to estimate the timing of the bender EMG. If antagonistic muscle activity alone explained the fact that opener- and stretcher-generated movements do not occur simultaneously, the opener EMGs should not occur alone: antagonistic muscles should be active whenever the opener (or stretcher) is. In *A*, the opener EMG burst is largely overlapped by the closer and extensor EMG bursts. This is not so in *B*, where there does not appear to be enough overlap between the opener and extensor EMGs (and bender, presumably) to suggest that antagonistic (bender) muscle activity overwhelms stretcher-generated tension. Grey boxes align start and end of representative opener bursts. Downward arrows aligned with end of closer burst; upward arrow aligned with start of extensor (substituting for bender) burst. Asterisk (*) shows pause in opener burst (see also Figure 3.27). EXT = extensor; CL = closer; OP = opener.



Discussion

The stability of the interjoint coordination during digging contrasts with the changes in interleg coordination (Chapter 2, Bilateral coordination: 47) and leg/tail coordination (Chapter 4, Coordination of the legs and "tail": 162) that occur in the transition from moving above sand to digging in sand. It also differs from the comparatively labile motor output during unrestrained walking [Ayers & Clarac 1978; Jamon & Clarac 1995]. The similarity of interjoint coordination in two sand crab species of different families suggests stability over evolutionary time-scales as well, which contrasts with the divergent patterns of interleg coordination in the same sand crab species. The comparative stereotypy of interjoint coordination in the sand crabs, both in the physiological and evolutionary time scales, might be due to the homogeneous nature of the substrates that sand crabs move through: water and fine sand.

Predictions about the digging pattern generators

There is general consensus that patterned motor output is a result of the interplay between extrinsic (i.e., sensory input) and intrinsic (i.e., central motor programs) factors.

Sensory input

Sensory input is obviously very important in regulating digging, as shown by how changes in load alter the motor output of sand crabs legs. When unloaded (during "swimming" above sand), the power and return stroke durations in leg 2 increase with period, as is the case with waving [Pasztor & Clarac 1983] and swimmeret beating [Davis 1969, 1971]. Conversely, when the legs are loaded (during digging), the power stroke duration is much more tightly linked with period than the return stroke duration is, which is similar to the relationships in walking lobsters [Ayers & Davis 1977], although the muscles functioning in the power stroke are not the same in sand crab digging as in either forward or backward walking (e.g., the depressor is a power stroke synergist in walking species, whereas the levator is a power stroke synergist in sand crabs). Assistance reflexes could cause such changes in motor output. Because the drag of the sand will be greatest

during the forward movement in leg 2 (due to the higher velocity of the tip and the large surface area presented by the leg surface; Chapter 2, Tip trajectories: 21), a likely candidate for generating such assistance reflexes is a proprioceptor signalling promotion of the coxa. In crayfish, promotion of the coxa is signalled by a thoracic-coxal chordotonal organ, which causes a positive feedback (assistance) reflex [Skorupski et al. 1992]. Other likely candidates are proprioceptors of the carpus-propus joint, because this joint, like the thoracic-coxal joint, is nearly at right angles to the forward movement of the whole limb. In walking species, the proprioceptors at this joint often consist of a pair of chordotonal organs [Bush 1962, 1965] and an apodeme tension receptor [Clarac 1977]. Reflexes generated by the chordotonal organs have been well studied in static situations [e.g., Bush 1962, 1965; Bush & Laverack 1982], but not yet in nerve cords producing rhythmical motor output.

The variability of the movement of leg 4 above sand suggests that sensory input is also important in regulating its motor output. Here, the remotion of the leg rather than the promotion may be a more important factor in regulating motor output, suggested by the tighter linkage between the remotor EMG burst duration with period than for other muscles. The thoracic-coxal muscle receptor organ signals leg remotion [Skorupski et al. 1992] and has a powerful influence on rhythmic motor output in crayfish [Sillar et al. 1986, 1987]. In crayfish and brachyuran crabs, it generates a suite of well-studied reflexes across multiple joints which are modulated to produce different effects [e.g., Head & Bush 1991, 1992; Skorupski & Bush 1992; Skorupski et al. 1994].

Central connections

In sand crabs, like many other arthropods [Dean 1992], the antagonistic muscle contractions at a single joint generally alternate. Alternation can be achieved by reciprocal inhibition between neurons [Selverston 1980]. In crustaceans, the motor neurons themselves may have such synaptic connections, and reciprocal inhibition between motor neurons appears to be partly responsible for generating oscillatory activity *in vitro* in the pattern generators that control the swimmeret [Heitler 1978], the stomatogastric system

[Harris-Warrick et al. 1992], and the proximal muscles in walking legs [Chrachri & Clarac 1989; Pearlstein et al. 1995; Skorupski & Sillar 1988]. In crayfish claws, there are several central monosynaptic connections between the opener and closer motor neurons, although the synaptic efficacy appears to be highly dependent on other central signals and there are no monosynaptic connections between OE \equiv SE and the closer excitors [Wiens & Atwood 1978].

Central inhibitory monosynaptic connections between motor neurons might explain the momentary lowering of the firing frequency of the opener/stretcher EMGs at the transition point between the opening and stretching movements in *B. occidentalis*. In crayfish claws, the opener inhibitor motor neuron (OI) inhibits the OE \equiv SE motor centrally, as well as exerting pre- and post-synaptic inhibition at the periphery [Wiens & Atwood 1978]. Thus, it is plausible that there could be a similar central connection between the stretcher inhibitor motor neuron (SI) and OE \equiv SE [Wiens 1982, Fig. 9]. In order to generate temporally distinct “stretching” and “opening” movements, OI alone should fire in the first half of the OE \equiv SE burst, and SI alone should fire in the second half of the OE \equiv SE burst. At the moment of transition between stretching and opening, both OI and SI may fire, their (hypothesised) central inhibition of OE \equiv SE spatially summing to momentarily silence OE \equiv SE.

Similarly, mutual excitatory synapses may be responsible for the grouping of synergists that work across multiple joints. For example, the bender, extensor, reductor, promotor may share common synaptic input, whether it be from a common interneuron(s) driving all the power stroke synergists or from reciprocal excitatory connections among the synergists. If their synergy was to be explained by reciprocal excitatory connections between motor neurons, those synapses would need to be strong to ensure the near synchronous onset of several synergists (Figure 3.5, Figure 3.6). No electrical synapses have yet been found between motor neurons controlling separate leg joints [Chrachri & Clarac 1989; Pearlstein et al. 1995; Skorupski & Sillar 1988]. Therefore, common input to synergist motor neurons is more likely than reciprocal excitation between the motor neurons [see also Büschges et al. 1994].

Some aspects of the interjoint coordination, however, are not easily explained by such simple hypotheses of central connections between motor neurons. For example, the onset of the dactyl movement in legs 2 and 3 always precedes that of the other power and return stroke synergists; similarly, elevation and depression are consistently the last movements to start. These distinct phase relationships are probably coordinated by a pool or pools of interneurons. In fictive crayfish walking, interjoint coordination similar to that seen in whole animals can be evoked by stimulating a local interneuron, whereas pharmacological agents induce oscillatory activity at one joint, but not coordination between joints [Pearlstein et al. 1995].

The differences between the digging motor pattern in legs 2 and 3 and in leg 4 imply that the neural circuitry controlling the legs also differs. There is a very large number of ways that different motor patterns could be generated in the ganglia controlling different legs, and examining all of them was not possible. One possibility that was investigated (see Chapter 6, Distal leg motor neurons: 187) is whether motor neurons in serially homologous ganglia differ in number or central anatomy (e.g., motor neurons innervating asymmetric lobster claws; Govind & Lang 1981). They do not (Figure 6.2). Physiological differences between motor neurons might explain (at least some of) the differences in motor output in different ganglia. For example, a central excitatory synapse between synergistic motor neurons of leg 2 may be absent, stronger, weaker, or inhibitory in the serially homologous cells in the ganglia controlling leg 4. Possible differences in number, morphology, and physiology of interneurons in segmentally homologous ganglia are unknown, and discovering them will be more difficult than differences among the motor neurons.

Is sand crab digging an evolutionary mosaic?

The search for the physiological causes underlying the different digging motor patterns in leg 2 and leg 4 can be guided by evolutionary hypotheses [e.g., Paul 1990, 1991; Paul & Wilson 1994]. As argued previously (Chapter 2, Interleg coordination, Discussion, Evolutionary origins for digging: 68), walking is a more plausible homologue

of digging than the other leg motor patterns (e.g., swimming, waving). It is difficult, however, to support an hypothesis of digging as either a modified form of forward or backward walking, because of the specialisation of the proximal muscle motor patterns in the different legs. Instead, I suggest that digging is an evolutionary mosaic, consisting of modified backward walking in legs 2 and 3 and modified forward walking in leg 4. This hypothesis generates some testable predictions, although testing these predictions requires greater understanding of the neuronal control of walking than we have now, particularly how decapods switch between forward and backward walking motor patterns. If, for example, interneurons are found that are active in forward walking but not backward walking, the mosaic hypothesis would predict that neurons homologous to those would be active during digging in leg 4 but not legs 2 and 3. At least one local interneuron with some of these properties has been recorded from in crayfish, but its anatomy and physiology are not yet fully characterised [Pearlstein et al. 1995]. Continuing research on the neural control of crustacean walking should provide new information which can be used to test hypotheses about the organisation of the digging pattern generators in sand crabs.

Although a better understanding of the neural circuitry underlying walking and digging would provide strong evidence for or against the mosaic hypothesis, other data are also informative. A comparison of interjoint coordination of the distal leg could provide information on the possible relationship between walking and digging. For example, the flexor and levator EMGs burst alternately during forward walking [Ayers & Clarac 1978; Barnes 1977; Macmillan 1975], whereas these two muscles burst synchronously in leg 4 in sand crabs (Figure 3.7). Likewise, the extensor and levator EMGs alternate in backward walking [Ayers & Clarac 1978] while bursting synchronously during digging by legs 2 and 3 in sand crabs (Figure 3.4). These observations weigh against the mosaic hypothesis, but there are gaps in the data on walking that complicate comparison of the motor patterns. First, distal joint coordination has either not been described for all the distal joints [Ayers & Clarac 1978; Macmillan 1975] or, when it has, only for forward walking [Barnes 1977]. Second, in spiny lobsters (infraorder Palinura),

neither forward nor backward walking produce strong, alternating EMG bursts in the extensor and flexor muscles (as they do during digging), but generate “diffuse,” unpatterned bursts [Ayers & Clarac 1978]. Third, palinurans appear to differ from both astacideans and anomurans in their distal leg motor organisation (Chapter 6, Do palinurans have different leg motor neurons?: 225). Finally, the distal joints make smaller contributions to walking than the proximal joints, and their motor output may be more flexible and less centrally determined; for example, the levator motor output seems to play the central role in organising walking [Ayers & Davis 1977]. The relative flexibility of the distal joints’ motor pattern on the physiological time scale may also be reflected in the evolutionary one, i.e., the motor pattern of the distal joint muscles may have been altered more than that of the proximal muscles during the evolution of sand crab digging.

Chapter 4: Coordination of the legs and “tail”¹

The difficulties in finding order in behavior are great enough to require all one’s attention... [Hebb 1949: xv]

Introduction

Most non-brachyuran decapods, including albuneids, can tailflip by rapidly flexing and extending the abdomen. Various studies have shown that “tailflipping” is actually a set of three neurologically distinct behaviours [reviewed in Wine & Krasne 1982]: two are non-repetitive startle responses initiated by giant interneurons, and the third is a voluntary locomotor motor pattern controlled by an undescribed group of non-giant neurons. In astacideans (and probably most macrurans), tailflipping is incompatible with rhythmic leg movements: the legs are instead streamlined by protraction of the legs at the basal joints [Cooke & Macmillan 1985]. Within the anomurans, neither galatheids (squat lobsters and porcelain crabs) nor sand crabs possess giant interneurons, but all but hippids perform non-giant tailflipping [Paul 1981a; Sillar & Heitler 1985; Wilson & Paul 1987]. In contrast, hippid sand crabs move their abdomen very little and swim by uropod beating instead [Paul 1971a, 1981a], and non-giant tailflipping and uropod beating are hypothesised to be homologous motor patterns [Paul 1981a, b, 1991]. Movements of the “tail,” either in the form of albuneid tailflipping or hippid uropod beating, aid members of both sand crab groups in digging: *E. portoricensis* uropod beat while digging [Trueman 1970], and experimental amputation in *E. analoga* showed that either the uropods or legs 4 are required for digging [D.H. Paul, personal communication]. The kinematics of albuneid tailflipping and hippid uropod beating have been analysed previously [Paul 1971a, 1981a, b], but the coordination between the “tail” and leg movements has not been examined in detail. There are two reasons to do so. First, the frequency of sand crabs’

¹ An abstract based on material in this chapter has been published [Paul & Faulkes 1995].

“tail” movements is higher than that of the legs [Trueman 1970; also Chapter 2, Interleg coordination, Ipsilateral coordination: 36], and it is an interesting problem of coordinating two motor patterns with intrinsically different frequencies to perform a particular function. Second, the ability of sand crabs to tailflip or uropod beat while simultaneously digging with their thoracic legs may be considered evidence against the hypothesised homology of digging and walking, because tailflipping does not occur during walking in most other decapods.

The methods were the same as described in previous chapters (Chapter 2, Methods: 18; Chapter 3, Methods: 74).

Results

Blepharipoda occidentalis and *Lepidopa californica*

The amplitude of abdominal movements is smaller than those of the legs (Figure 4.1). This suggests that the abdomen contributes to digging by stirring up the sand and making it fluid [i.e., a thixotropic effect; Cubitt 1969].

In *B. occidentalis*, the abdomen cycles $\sim 1.5\times$ faster than the legs when individuals are held in water (Figure 4.2), and there is no coupling between the two rhythms (Figure 4.4A). This changes as *B. occidentalis* digs: the abdominal frequency drops precipitously to approximately that of the legs (Figure 4.2), and the phase distribution “collapses” from an even distribution (Figure 4.4A) to a narrower one (e.g., $0.4 < \phi < 0.8$ in Figure 4.4B, C). Small cycle-to-cycle fluctuations in phasings do occur, perhaps due to different sensory input or the fact that the two pattern generators have different intrinsic rhythms. Since the abdomen comes to match the legs’ frequency, it appears that the legs influence the abdomen but not vice versa.

In *L. californica*, the frequencies of abdomen and leg EMGs are more nearly equal than in *B. occidentalis* (Figure 4.3), with the abdomen cycling $\sim 1-1.2\times$ faster than the legs. Consequently, it is not clear what coupling there may or may not be when individuals are above sand. Nevertheless, the frequency of abdominal EMGs drops to that of the legs

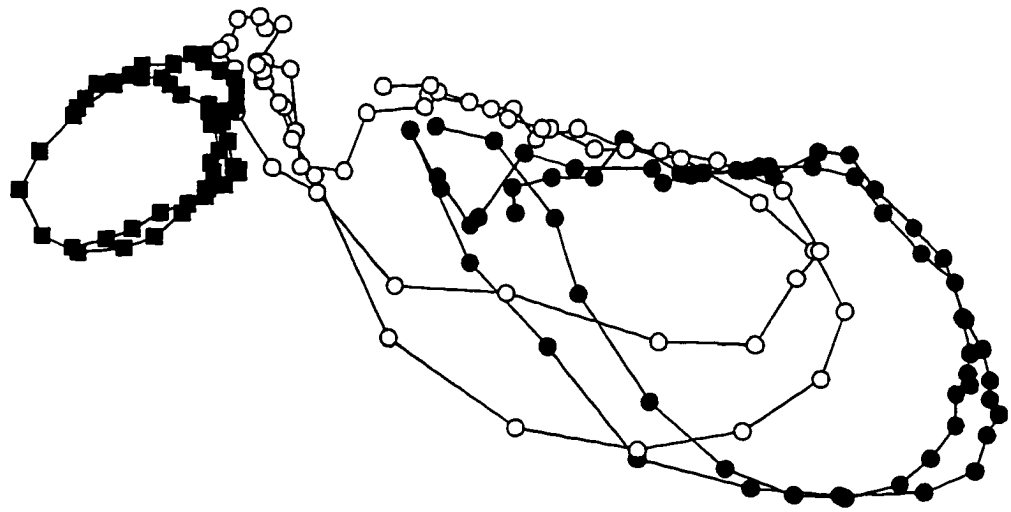
as *L. californica* digs (Figure 4.3), and the phase relationship between the abdomen and legs is not random when digging (e.g., $0.3 > \phi > 0.7$ in Figure 4.4D).

Figure 4.1: Tip trajectories of legs and “tail” in *B. occidentalis* and *E. analoga*

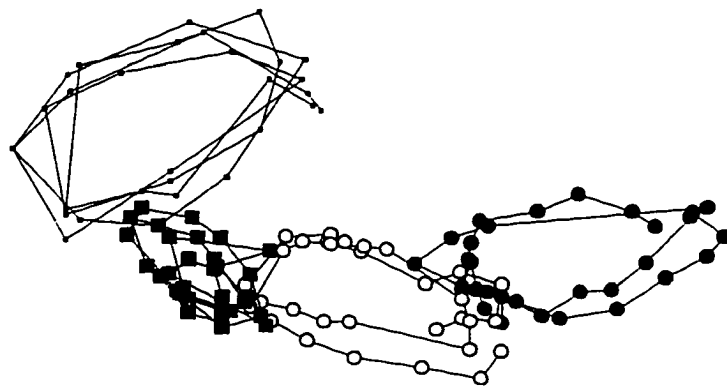
Amplitude of “tail” and leg movements. (A) Tip trajectories (ventral view; telson tip sometimes concealed by legs in side view) of legs and abdomen in *B. occidentalis*. Animal not held perfectly parallel relative to video frame. Compare with tip trajectories shown Figure 2.1. (B) Tip trajectories (side view) of uropods and legs in *E. analoga* (same data as Figure 2.3). Tips of dactyl for legs (A-B); center of telson digitised for abdomen (A); tip of ramus digitised for uropod (B), digitised using Peak 5 movement analysis system. Interval between points = 16.7 ms.



- Leg 2
- Leg 3
- Leg 4
- Abdomen (A), Uropods (B)



(B)

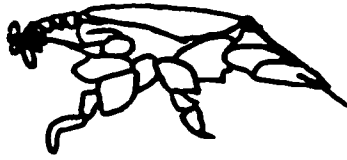


1 cm

Figure 4.2: Coordination of leg and abdomen in *B. occidentalis*

Representative EMGs from leg 2 closer and axial abdominal muscles (probably flexors).

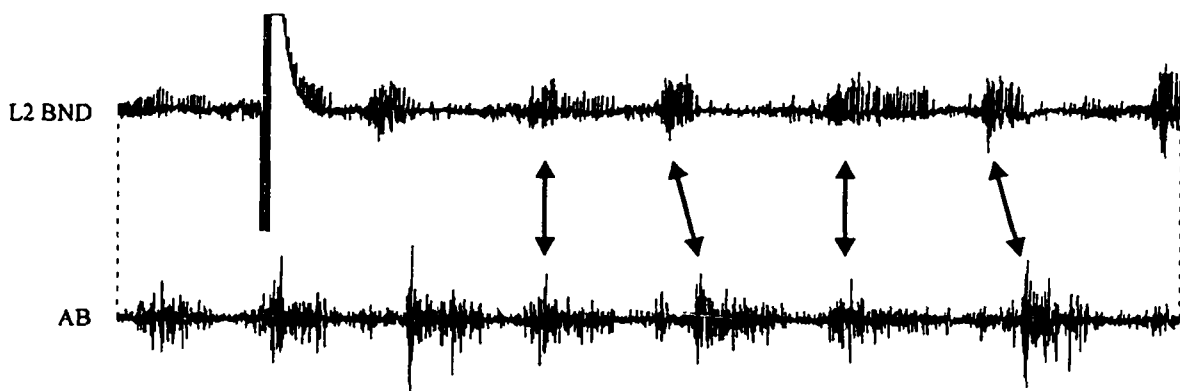
This record is from an animal "swimming" as it was held in the water column (start of record) and digging (start of dig shown by double arrow between traces). CL = L2 closer; AB = abdomen.



500 ms

Figure 4.3: Coordination of leg and abdomen in *L. californica*

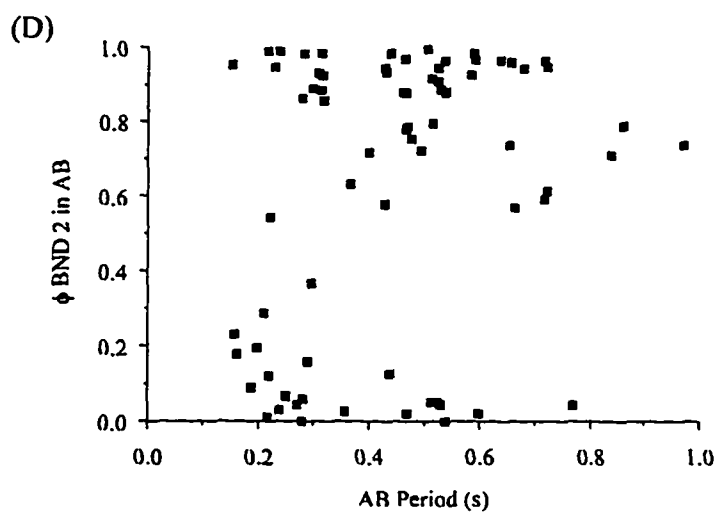
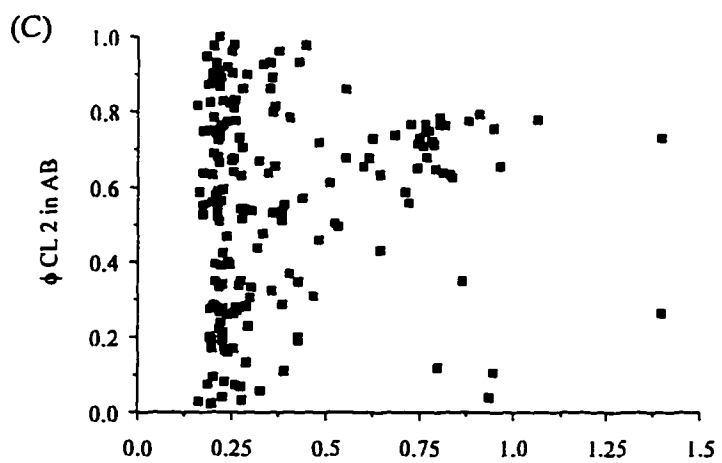
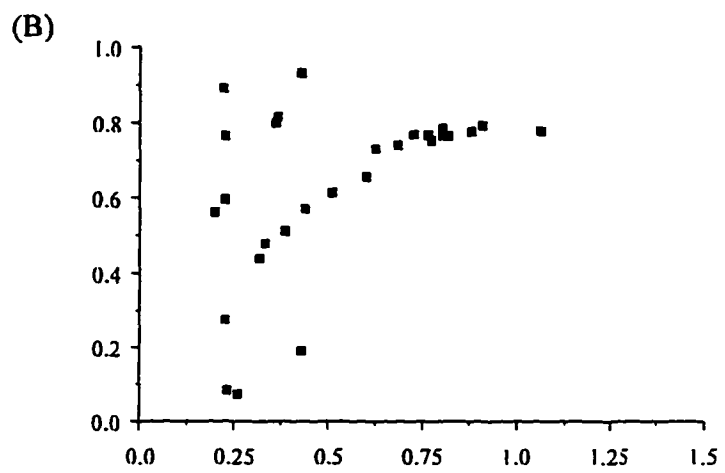
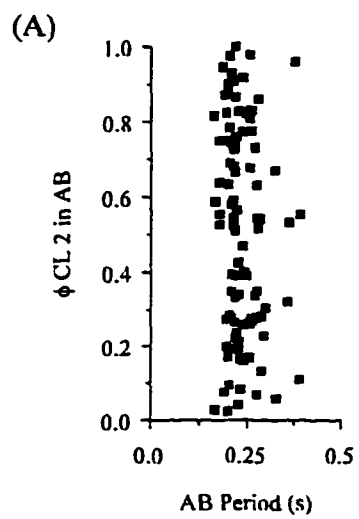
Representative EMGs from leg L2 bender and axial abdominal muscle (probably flexors). Digging begins at the start of the record. Double arrows between traces show small shifts in phase relationship between leg and abdomen. CL = closer; AB = abdomen.



500 ms

Figure 4.4: Coordination of leg and “tail” in *B. occidentalis* and *L. californica*

Phase/period plots of leg 2 phase versus abdomen period in albuneids. Plots of (A) one long swimming sequence above sand, (B) a single digging sequence, and (C) combination of both swimming and digging in *B. occidentalis*. C includes data from A and B. (D) Plot of several digging sequences in *L. californica*. One possible reason why the phase relationship in C shows alternation at long periods (i.e., when digging) whereas D shows near synchrony at long periods is that the closer (a return stroke muscle) was recorded in C, whereas the bender (a power stroke leg muscle) was recorded in D, and these two muscles alternate (see Chapter 3, Movement analysis of interjoint coordination in *B. occidentalis*: 83). n = (C) eight digs from two animals; (D) n = three digs from one animal.



Emerita analoga

The uropods of *E. analoga*, while smaller relative to the thorax than the abdomen in albuneids, make larger amplitude movements than the legs (Figure 4.1), which suggests that the uropods may effectively shovel the sand and cause thixotropy by their high frequency of beating. When *E. analoga* is beginning to dig, uropod beating frequencies are often about double those of legs 2 and 3 and can be about equal to those of leg 4 [Trueman 1970; see also Figure 2.6]. Like the abdomen in albuneids, the uropod beating frequency tends to drop dramatically during a digging sequence (Figure 4.5) to about that of legs 2 and 3 as *E. analoga* digs (Chapter 2, Speed: 33).

There is loose coupling between the uropods and leg 4. For example, the leg 4 depressor muscles and the uropod power stroke muscle generally alternate, regardless of whether the bilateral leg 4 EMG bursts are occurring alternately or synchronously (Figure 4.6, Figure 4.7). This corresponds to what was seen on some video sequences: the uropods and legs 4 performed alternating power stroke movements. During the uropods' return stroke, legs 4 would move laterally, which would apparently serve to "brace" the legs in the sand. During the uropods' power stroke movement, legs 4 would move medially, thus "streamlining" the legs.

Figure 4.5: EMGs of leg 4 and “tail” in *E. analoga*

Coordination of leg 4 and uropods in *E. analoga*. Representative EMGs from uropods and leg 4. These EMGs show the very high frequency of the uropods during swimming and early in a digging sequence, when initial leg EMGs are minimal. Leg 4 EMGs begin at about the same frequency as the uropods; the frequency of both then quickly drops.

STR = leg L4 stretcher EMG; UR = uropod EMG; PS = burst of power stroke muscle;

RS = burst of return stroke muscle.

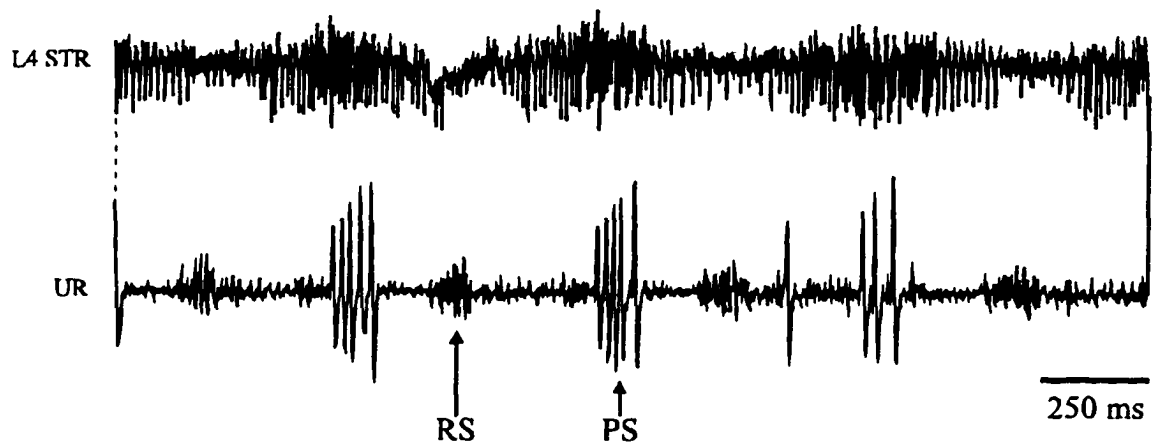
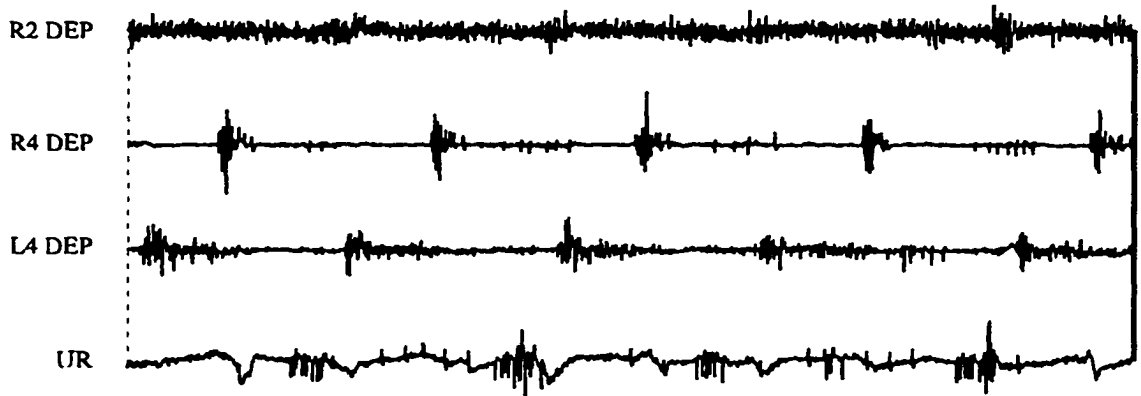
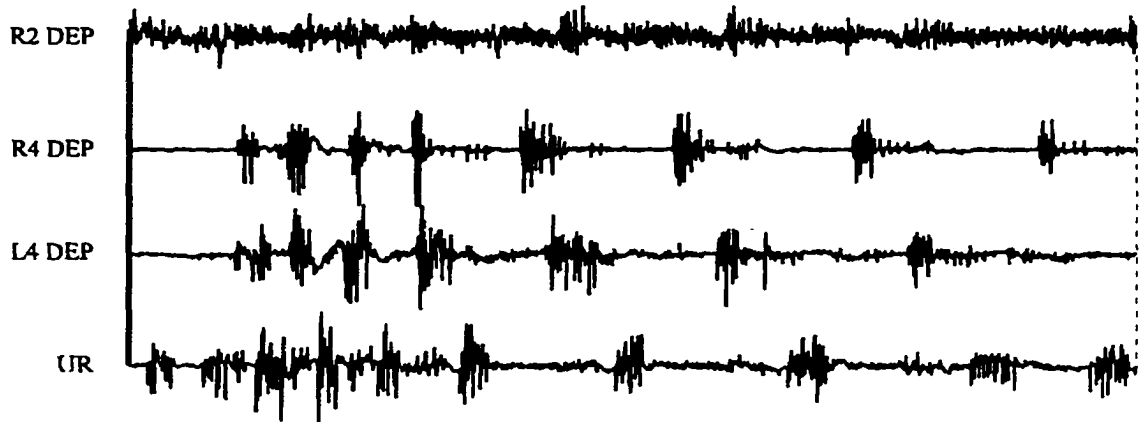


Figure 4.6: EMGs of legs 2, 4, and "tail" in *E. analoga*

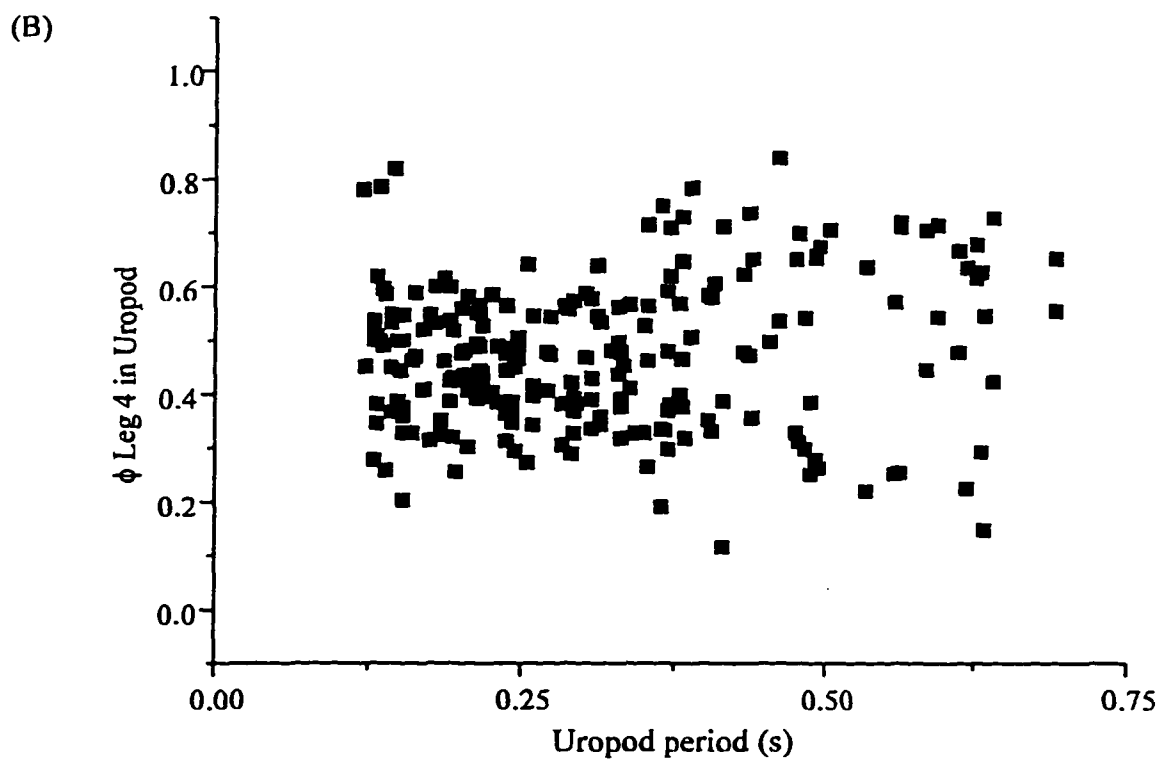
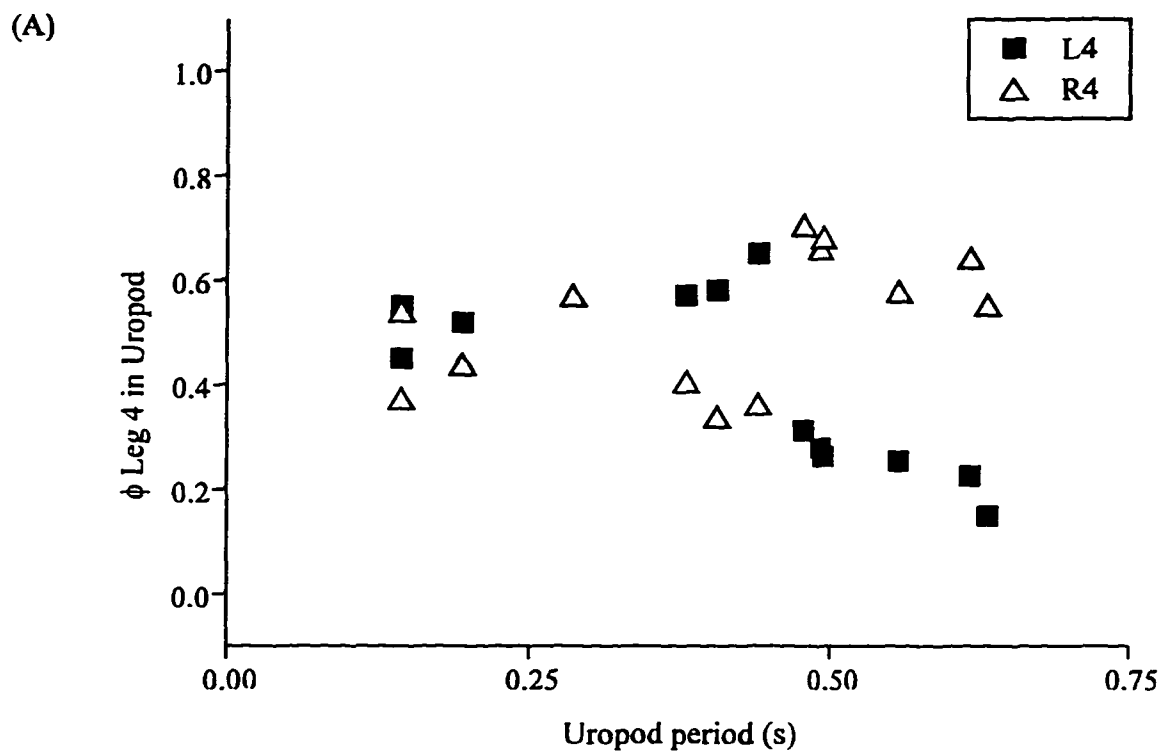
Coordination of leg 2, legs 4, and uropods in *E. analoga*. Representative EMGs showing that EMGs from the uropods and legs 4 alternate, regardless of whether the bilateral legs 4 are synchronous (start of record) or are alternating (end of record). R = right; L = left; DEP = EMG of leg depressor muscle; UR = EMG of uropod muscles (large bursts = power stroke muscle). See also Figure 2.18.



250 ms

Figure 4.7: Coupling of leg 4 and “tail” in *E. analoga*

Phase/period plots of legs 4 phase versus uropod period in *E. analoga*. (A) Plot of data from single digging sequence. (B) Plot of phases of legs 4 (both left and right) against uropod period. The phase of the legs relative to the uropods become more variable at longer periods, but the leg EMG bursts remain asynchronous with those of the uropods. For bilateral coordination of legs 4, see Chapter 2 (Bilateral coordination, *Emerita analoga*: 58). Leg EMGs recorded from depressor muscle in both A and B. n = (B) eight digs by three animals.



Antennal anecdotes

Although the antennae do not have any obvious function in digging, there appears to be coupling between movements of the first antennae and tailflipping in both *B. occidentalis* and *L. californica*: the antennae are depressed at the same time as the abdomen flexes. Also, *B. occidentalis* ends its digging sequence by quickly moving its first antennae back and forth a few times. No digging movements are evident after these antennal movements, unless individuals are disturbed.

Discussion

Some features of the coordination between the legs and abdomen/uropods are similar in the three sand crab species. Rhythmic leg and “tail” movements can occur completely independently of each other; the frequencies of “tail” movements tend to be higher than the legs’, and; when individuals are above sand, there is no coupling between legs 2 & 3 and the “tail.” There is one major difference between the albuneids and *E. analoga*. In the albuneids, legs 4 always cycle at the same frequency as the other legs, not at the same frequency as the abdomen.

In the albuneids, sensory input that occurs during digging (i.e., load) appears to alter the motor output of the abdomen (in addition to altering interleg coordination; Chapter 2, Bilateral coordination: 47). If the drop in abdominal frequency was due to the mechanical effects of drag alone, both motor patterns would be expected to drop in frequency, while maintaining the same coordination between the legs and abdomen in sand as in water (i.e., no coupling). The equilibration of the abdominal frequency to that of the legs and the change in phase relationship between the two (Figure 4.4C) argue against the notion that the change in abdominal frequency is due to drag, but is rather caused by afferent-driven changes in central motor output. This can be considered as an example of the “magnet effect” [von Holst 1937, reprinted in Gallistel 1980], where the strong activation of one motor pattern causes the entrainment of another, largely autonomous motor pattern.

In *E. analoga*, legs 4 and the uropods can cycle at the same frequency [see also Trueman 1970], and the two pairs of limbs alternate with each other. Some results tentatively suggest that the coupling between these limbs may be due, at least in part, to sensory signals sent between the thoracic and abdominal ganglia. Tactile stimulation of the legs can elicit short bouts of alternating activity in uropod power- and return-stroke motor neurons [Paul 1971c]. Similarly, in an isolated ventral nerve cord, increased tonic activity in the terminal abdominal ganglion greatly enhances uropod motor neurons' reflex response to stretch; such increased tonic activity can be caused by stimulating distal leg nerves [D.H. Paul, personal communication]. The coupling between the pattern generators for the uropod beating and the legs may be responsible for the bilateral synchrony of legs 4 seen during high frequency movements. Because uropod beating is normally a bilaterally symmetrical behaviour [Paul 1971a], any influence of the uropod pattern generator on those of legs 4 would also tend to be bilaterally symmetrical, resulting in bilaterally synchronous movements of legs 4.

Initially, I hypothesised that the coupling between legs 4 and the uropods was restricted to the hippids, and was a result of the major reorganisation of the abdomen and tailfan [Paul 1989, 1991, 1994] that occurred during the evolution of uropod beating. This hypothesis may be weakened by one observation of a single *L. californica* moving legs 4 in bilateral synchrony while legs 2 were moving in bilateral alternation. This might suggest that the coordination of leg 4 in *E. analoga* may have resulted from strengthening neural connections that existed prior to the origin of uropod beating.

Digging = Walking (modified) + tailflipping?

The fact that digging leg movements and rapid "tail" movements occur concurrently in sand crabs but not in most walking decapods [Cooke & Macmillan 1985] may speak against the hypothesis that digging leg movements evolved from walking. Nevertheless, leg and "tail" movements are not absolutely incompatible, even in astacideans. For example, in crayfish, the abdomen moves rhythmically during backward walking on land [Kovac 1974], and the leg and tail rhythms are initiated by the same

command system [Simon & Edwards 1990]. It is unlikely, however, that sand crab digging is directly related to this behaviour because the abdominal movements during crayfish backward walking are generated by slow extensors and flexors [Kovac 1974], rather than the fast extensors and flexors used in tailflipping. Likewise, *M. quadrispina* tend to streamline their legs during full tailflipping [Wilson & Paul 1987], but will often perform “searching” movements with their legs during truncated tailflips, usually just prior to perching on a rock or some other surface [unpublished observations]. Within the sand crabs, the loose coupling between digging leg movements and tailflipping show that the two are separate motor patterns, almost certainly controlled by separate neural circuits. All that would need to occur over evolutionary time for the two behaviours to be performed concurrently is weakening of any excitation of the promotor muscles [i.e., those responsible for streamlining the legs; Heitler & Fraser 1989] that occurs during non-giant tailflipping, and reducing any inhibition that non-giant tailflipping may have on the output of other leg muscles.

Chapter 5: Attempts to elicit fictive digging

There are no experimental failures. There's only more data. [Cassutt 1987]

Introduction

Since Selverston [1980] asked "Are central pattern generators understandable?" in a review article of the same name, the answer has been, "Yes" [e.g., Delcomyn 1980; Harris-Warrick et al. 1992; Pearson 1993]. Much of the success in understanding central pattern generators has depended on developing ways of maintaining a nervous system largely or entirely disassociated from the periphery in a state that still produces patterned motor output that resembles that seen in intact animals. Because there is no musculature in such preparations for the motor output to act upon, such rhythmic activity is known as "fictive locomotion." How closely this motor pattern must resemble the original behaviour to qualify as fictive locomotion "depends greatly upon the depth of knowledge about the intact motor output and on the theoretical standpoint of the investigator" [Büschges et al. 1995].

Theoretical issues aside, many studies on a wide variety of taxa have purported to demonstrate fictive locomotion [e.g., lamprey swimming, Grillner et al. 1995; locust walking, Ryckebusch & Laurent 1993; rat walking, Cazalets et al. 1995], including crustacean walking. Preparations have been developed in which thoracic ganglia, isolated except for a few sensory organs, generate fictive walking in crayfish [Skorupski & Sillar 1988; Sillar et al. 1986, 1987]. Spontaneous fictive walking is rare, but motor output from the thoracic ganglia can often be "organised" into a fictive walking pattern by rhythmic stimulation of thoracic-coxal proprioceptors [Sillar et al. 1986, 1987]. Similarly, bath application of the cholinergic agonists pilocarpine and oxotremorine can elicit fictive walking in crayfish [Chrachri & Clarac 1987, 1990], presumably because their action mimics sensory stimulation of crustaceans' cholinergic sensory neurons.

I tried to emulate these methods in an attempt to elicit "fictive digging" in sand crabs and "fictive walking" in squat lobsters.

Methods

Blepharipoda occidentalis and *Munida quadrispina* were collected and housed as described in Chapter 2. *B. occidentalis* (n = 10) and *M. quadrispina* (n = 17) of both sexes were debrained. The viscera were removed and the skeleton and musculature dissected away, except that one distal leg (usually leg 2 or 4) was kept attached to the nerve cord, when possible. All the thoracic and abdominal ganglia of the ventral nerve cord were kept. The nerve cord and leg were pinned out in a Sylgard-lined dish and the thoracic ganglia desheathed with forceps. The preparation was superfused with physiological saline for the duration of the experiments. Plastic-tipped suction electrodes were used to record from the leg nerves. Normally, several leg nerves were recorded from at once in hope of increasing the probability of detecting any motor output. Preparations were monitored for any spontaneous activity for 45-60 minutes before any pharmaceuticals were added to the dish. Pilocarpine or oxotremorine was added so that the final bath concentration was normally 10^{-5} M; bath concentrations were varied in a few preparations from 10^{-6} to 2×10^{-4} M. Different motor neurons could be distinguished from each other on the basis of spike height in the extracellular recordings.

Results

Although tonic motor output was seen in a good proportion of the experiments, no rhythmic activity was seen under any condition in either *B. occidentalis* or *M. quadrispina*. Neither applying pilocarpine nor oxotremorine had any consistent effect on neural activity, such as increased tonic firing. When more than one neuron was firing tonically, there was no detectable correlation between the firing of the cells. Single motor neurons rarely fired in bursts, but these bursts were not repetitive. There were no cases where two motor neurons (distinguishable by spike amplitude) were bursting.

Discussion

The muscarinic agonist pilocarpine induces rhythmic activity in isolated ganglia belonging to a diverse collection of arthropods, including crayfish [Chrachri & Clarac

1987, 1990], locusts [Ryckebusch & Laurent 1993], larval moths [i.e., caterpillars; Johnston & Levine 1995], and stick insects [Büschges et al. 1995]. In contrast, neither pilocarpine nor oxotremorine had any apparent effect on the motor output of the thoracic ganglia of either *M. quadrispina* or *B. occidentalis*.

There are several potential explanations for the lack of patterned motor output in these species. First, I did not perfuse animals with saline prior to the main dissection, which (unknown to me at the time) is critical to successfully eliciting rhythmic activity in crayfish [B.M.H. Bush, personal communication; M.D. Gill, personal communication; P. Skorupski, personal communication; K.V. Wareham, personal communication]. Other factors that may have contributed to the lack of success include, for example, not oxygenating the saline during the experiments, poor control of the rate of saline superfusion, and using a physiological saline that was not optimised for the two species. Any or all such technicalities may well be crucial, due to the long time (60-90 minutes) an experiment takes to prepare.

Second, the dose may have been too low or high. Dose concentration was based on methods of Chrachri and Clarac [1987, 1990] and comparable to Ryckebusch and Laurent [1993], but their doses (and mine) were lower than that which most reliably generates rhythmicity in stick insect thoracic ganglia [Büschges et al. 1995].

Third, pilocarpine and oxotremorine appear to be effective at turning on only a small number of rhythmic behaviours, primarily those where sensory input is important in determining the rhythmicity of motor output, probably because pilocarpine mimics cholinergic input from sensory afferents [Büschges et al. 1995]. In tobacco hawkmoth (*Manduca sexta*) larvae, pilocarpine turns on fictive crawling [Johnston & Levine 1995], but it is only one in a very wide repertoire of rhythmic behaviours, and pilocarpine does not appear to start any of the others [R.M. Johnston, personal communication]. Similarly, pilocarpine seems less effective at eliciting rhythmic activity where the motor output is determined centrally [Büschges et al. 1995]. Because *B. occidentalis* is able to make rapid, vigorous leg movements in air or water as well as under sand, it may be that the role of sensory input in producing rhythmicity is relatively minor; consequently, pilocarpine

may be inadequate to turn on a fictive digging pattern. In contrast, however, *M. quadrispina* often walk over very uneven terrain: sensory input is undoubtedly important in producing coordinated stepping, so one would guess that pilocarpine should have an effect on *M. quadrispina* similar to that in crayfish. *Munida quadrispina* walk little and then only slowly, however; rapid locomotion is accomplished by tailflipping [personal observations]. The immobile habits of *M. quadrispina* suggests that the neural circuitry underlying walking has a high activation threshold. Walking may be initiated and heavily influenced by descending input from higher centres in the brain (i.e., command neurons for “voluntary” movement; “free will”), which are probably not cholinergic pathways and would not be stimulated by cholinergic agonists.

Chapter 6: Distal leg motor neurons¹

To experiment first is human, to describe first, divine.

[Kroodsma & Byers 1991: 325]

Introduction

Decapod crustacean leg neuromusculature has been profitably investigated for over a century [Atwood 1977; Wiens 1989]. Most of this work has focused on the leg muscles distal to the coxa (hereafter "distal") in the reptantians. Wiersma and Ripley [1952] found that the distal leg muscles of all reptantian species studied had the same excitatory innervation: one excitatory motor neuron shared between the opener and stretcher muscles, four flexor excitors, two excitors each to the closer, bender, and extensor, and one specific excitor to the accessory flexor muscle. Later it became apparent that the inhibitory innervation of these muscles is also very similar in the reptantian infraorders Brachyura, Astacidea, and Anomura: one common inhibitor that innervates every leg muscle (including the proximal ones) and a specific inhibitor each to the opener and stretcher muscles [reviewed in Wiens 1989]. There is species [e.g., Wiens & Govind 1990] and segmental variability [e.g., Wiens 1993] in how many muscles a given motor neuron innervates, but only two studies have suggested any differences in the total number of motor neurons. First, the opener inhibitor motor neuron may be missing in Palinura [Wiersma & Ripley 1952; Silvey 1981]. Second, two putatively inhibitory neurons are associated with the flexor muscle in shore crabs, *Carcinus maenas*, in addition to the four excitors and common inhibitor conventionally described, but their physiological effects have not been demonstrated yet [Parsons 1982]. Nonetheless, the peripheral innervation in a large number of reptantians is more similar than the diverse behaviour these cells

¹ A slightly different version of this chapter has been accepted for publication as: Faulkes, Z. & Paul, D.H. 1996. A map of the distal leg motor neurons in the thoracic ganglia of four decapod crustacean species. *Brain, Behavior and Evolution*: in press.

generate. Thus, leg neuromusculature provides a nearly ideal system to study evolutionary change in behaviour, because:

... differences between neurons have been identified against a background of overwhelming similarity of neural organization. These differences provide some of the best potential material for analyzing the divergence of neural networks and of the behaviors they subserve, since linkage to behavior is strong. [Arbas et al. 1991: 27-28]

We know far less about the central properties of these well-studied motor neurons than we do about their peripheral characteristics. This limits some of our understanding of the neural circuitry responsible for behaviours involving the legs, like walking [Barnes 1977], the defence response [Kelly & Chapple 1990], and digging. Further, knowing the central characteristics of the leg motor neurons could help to illuminate the evolutionary history of arthropods in general and decapod crustaceans in particular. For example, the two extensor excitors exit via different nerves in signal crayfish, *Pacifastacus leniusculus*, and Wiens [1993] has suggested that this feature may be homologous to the separate routings of tibia extensor motor neurons of locusts. This is a reasonable hypothesis in light of the similar cytoarchitecture of crustacean and insect thoracic ganglia [Elson 1995; Wiens & Wolf 1993] and the increasing evidence that insects and crustaceans form a monophyletic taxon [Averof & Akam 1995]. Obviously, this hypothesis would be strengthened if the same axonal pathways were found in many species of crustaceans, particularly because this separation has not been reported in other species [Wiersma & Ripley 1952; Silvey 1981], and axons' locations in the distal leg nerves seem quite variable across decapod taxa [Wiersma & Ripley 1952]. To date, fewer than half the distal leg motor neurons have had their position in the ganglion identified via physiological techniques, and those in only a few species [Govind & Lang 1981; Silvey 1981; Wiens 1976; Wiens & Wolf 1993]. Other anatomical methods, such as backfilling, can more readily provide an overview of the total number and central positions of neurons in a broader range of species, but comparisons of published studies using such techniques give an equivocal picture (Table 6.1). It is difficult to interpret these apparent species differences for two reasons. First, the reductor muscle's excitatory innervation has not

been completely described [but see Wiens 1993]; nevertheless, it seems unlikely that the reported variability in cell numbers stems from species differences in the innervation of this one muscle. Second, these anatomical studies were not expressly comparative, so methodological differences may account for or contribute to some of the reported differences. Few studies have expressly examined the location of a cell body in the ganglion, the nerve from which the axon initially exits the ganglion, and the location of the axon in the distal nerve; these last two aspects are not synonymous because it is possible for axons to traverse between nerves. For example, the common inhibitor axon can exit the ganglion via one distal leg nerve, then bifurcate further out and have branches in both distal leg nerves [Wiens 1990; Wiens & Rathmayer 1985].

Table 6.1: Review of distal leg motor neuron number and exit route

Number of distal leg motor neurons described in the literature through studies of axons at periphery and somata positions in the ganglion. Species are omitted from this table if the innervation scheme of most of the seven distal muscles (opener, closer, stretcher, bender, extensor, flexor, accessory flexor) has not been worked out. Some early findings [e.g., Wiersma & Ripley 1952] are now strongly suspected to be wrong [Wiens 1989] in light of more recent work on the innervation of individual muscles, usually in different species; revised estimates are given in parentheses, with relevant results described in notes below table. Reference abbreviations: (1) Bévangut et al. 1983; (2) Chrachri & Clarac 1989; (3) Govind & Lang 1981; (4) Moffett et al. 1987; (5) Silvey 1981; (6) Wiens 1976; (7) Wiens 1990; (8) Wiens 1993; (9) Wiens & Govind 1990; (10) Wiens & Rathmayer 1985; (11) Wiens & Wolf 1993; (12) Wiersma 1941; (13) Wiersma 1951; (14) Wiersma & Ripley 1952; (15) Wilson & Sherman 1975.

Table 6.1

Infraorder Family Species	Total # axons at periphery # Axons in each nerve	Total # somata in ganglia Exit routes	# Anterior- lateral somata Exit routes	# Posterior- lateral somata Exit routes	# Medial somata Exit routes
Anomura Paguroidea Hermit crab, <i>Dardanus asper</i>	15 ¹⁴ 9 NIAV 6 NIPV	—	—	—	—
Astacidea Nephropidae Common lobster, <i>Homarus vulgaris</i>	16 ¹³ (15 ⁷) * 8 NIAV 8 NIPV ¹³	—	—	—	—
American lobster, <i>Homarus americanus</i>	15 ⁹	31-37 ¹⁵ 13 NIAV 16 NIPV 2-4 unclear	18 ¹⁵ 13 NIAV 5 NIPV	11 ¹⁵ 11 NIPV	2-4 (1-2 ant., 1-2 post.) ¹⁵ 2 NIAV 2 NIPV
Cambaridae Red swamp crayfish, <i>Procambarus clarkii</i>	10 ^{11,12} (15 ¹⁴) † 3 NIAV 7 NIPV ^{11,12}	20 ² 9 NIAV 11 NIPV	7 ² 7 NIAV	12 ² 1 NIAV 11 NIPV	1 ² At least 2 (post.) ¹¹ 1 NIAV ^{2,11} 1 NIPV ¹¹
Spinycheck crayfish, <i>Orconectes limosus</i>	—	18 ¹¹	12 ¹¹	3 ¹¹ 1 NIPV	3 ¹¹ (2 post., 1 ant.) 1 NIAV 1 NIPV
Astacidae Signal crayfish, <i>Pacifastacus leniusculus</i>	15 ⁸ 7 NIAV 8 NIPV	—	—	At least 1 ¹¹ 1 NIPV	At least 2 (post.) ¹¹ 1 NIAV 1 NIPV

(Continued on next page)

Table 6.1 (Continued)

Brachyura					
Portunidae					
Blood-spotted swimming crab, <i>Portunus sanguinolentus</i>	15 ¹⁴ (16? ¹⁰) ‡	—	—	—	—
Shore crab, <i>Carcinus maenas</i>	—	—	—	—	At least 1 ^{1,4}
Palinura					
Palinuridae					
Spiny lobster, <i>Panulirus</i> spp.	14 § 6 NIAV 8 NIPV ¹⁴	—	—	—	—
Southern rock lobster, <i>Jasus novaehollandiae</i>	—	16 ⁵ 8 NIAV 8 NIPV	11 ⁵ 8 NIAV 3 NIPV	4 ⁵ 4 NIPV	1 ⁵ 1 NIPV
Scyllaridae					
Sculptured slipper lobster, <i>Paribaccus antarcticus</i>	14 § 6 NIAV 8 NIPV ¹⁴	—	—	—	—
Thalassinidea					
None examined	—	—	—	—	—

Notes: * The overestimate in [13] is due to the fact that CI branches proximal to the autotomy plane [7]. † The flexor muscle and accessory flexor muscle were not examined in this species; these are generally agreed to have four excitors and one specific excitor, respectively [14]. ‡ The innervation pattern in [14] shows three inhibitory axons, the generally accepted number, but innervation of the muscles was atypical, consisting of a specific SI, and two inhibitory axons innervating multiple muscles. The latter two neurons may be branches of CI resulting from the axon bifurcating proximal to the ischium or within it; in *Eriphia spinifrons* and *Cancer pagurus*, CI does not branch proximal to the autotomy plane [10]. Although a specific OI was not found in [14], it has been in *E. spinifrons* and *C. pagurus* [10]. It is most likely that this species, like other brachyurans, conforms to the general scheme of having three inhibitory motor neurons. § OI not found.

I studied four reptantian species: spiny sand crabs *Blepharipoda occidentalis* (Anomura: Albuneidae), mole sand crabs *Emerita analoga* (Anomura: Hippidae), squat lobsters *Munida quadrispina* (Anomura: Galatheidae), and signal crayfish *Pacifastacus leniusculus* (Astacidea: Astacidae). I focused on anomurans because the original descriptions of their distal leg innervation [Wiersma & Ripley 1952] have not been revised [Wiens 1989] and were based solely on hermit crabs (Paguroidea). It is an open question whether paguroid leg innervation is representative of the other two anomuran superfamilies, the squat lobsters and porcelain crabs (Galatheoidea) and sand crabs (Hippoidea). I examined *P. leniusculus* to compare my findings to the mainly astacidean-based literature. As described in previous chapters, these four species show dramatic behavioural differences in how they use their legs, which are greater than the serial differences between crayfish claws and walking legs [Wiens & Wolf 1993]. Thus, sand crabs are promising candidates for revealing phylogenetic differences in distal leg neuromusculature. Finally, describing the leg motor neurons is an initial step towards characterising the neural circuitry underlying sand crab digging. Crustacean motor neurons often make central synaptic connections, and can form part of the circuitry shaping the motor pattern [stomatogastric system, Harris-Warrick et al. 1992; swimmerets, Heitler 1978; legs, Chrachri & Clarac 1989; Skorupski & Sillar 1988; Wiens & Atwood 1978].

Methods

Blepharipoda occidentalis Randall, 1839 and *Emerita analoga* (Stimpson, 1857) were collected in Monterey Bay, California. *Munida quadrispina* Benedict, 1902 were collected by trawling from the MSSV *John Strickland* in Saanich Inlet, Vancouver Island, British Columbia. *Pacifastacus leniusculus* (Dana, 1852) were collected from Vancouver Island lakes. All were housed in the University of Victoria's aquatic facilities.

I stained reductor motor axons using reduced methylene blue [Baker 1958]. Legs were severed at the thoracic-coxal joint, and the coxa removed to expose the proximal surface of the reductor muscle. A few drops of reduced methylene blue were added to the bath, and the tissue was chilled at about 5°C until optimally stained.

The leg ganglia are the five most posterior of eight embryonic ganglia in the thorax; the anterior thoracic three ganglia fuse with three head-associated ganglia to form the subesophageal ganglia [Wallis 1995]. Thus, T4 innervates the claw, T5 innervates the second leg (the first "walking leg"), and so on. I filled nerves of T4-8 in *P. leniusculus* and of T4-7 in *M. quadrispina*, *B. occidentalis*, and *E. analoga*. In the anomurans, T7 and T8 are fused with each other and the first abdominal ganglion (A1). As a result, T8 is relatively far from the leg it innervates and the nerve branching pattern is different from that in the more anterior legs. Methylene blue stains showed that the leg nerve (N1) separates into discrete branches innervating the proximal and distal leg quite far away from the ganglion: the two distal leg nerves (N1AV and N1PV) [for leg nerve nomenclature, see Elson 1995] and one proximal leg nerve (probably N1PD) project to leg 5 in one large nerve trunk. Consequently, obtaining a fill of only N1AV or N1PV in T8 was not practical. Preliminary backfill results, however, suggest that the organisation of the distal leg motor neurons in T8 of the anomuran species is the same as in the more anterior ganglia.

Backfills were made by standard methods [Pearson & Fournier 1974; Pitman et al. 1972] and silver-intensified [Bacon & Altman 1977]. Animals were debrained by cutting across the carapace behind the eyes, followed by removal of the carapace and the viscera. Surrounding skeletal and muscular tissue was removed until the thoracic ganglia could be lifted out. Thoracic ganglia were separated so that each ganglion could fill in a separate dish, minimising the risk of leakage or other mishap ruining an entire chain of ganglia. This could not be done in *M. quadrispina* because the thoracic ganglia are fused together. In most species, the leg nerve (N1) separates into an anterior ventral (N1AV) and posterior ventral (N1PV) branch [Elson 1995] which could be teased apart. In *E. analoga*, however, the distal leg nerve is unbranched: I call this nerve N1(A+P)V to emphasise its relationship to the two nerves in the other species studied. The distal end of the leg nerve was placed in a Vaseline well containing 0.3 M cobalt chloride and cut. The well was then sealed. Fills were usually left for 16-20 hours at 5°C. The cobalt chloride was then precipitated with a few drops of ammonium sulphide, and the ganglia were then fixed

(10% formalin in crab saline), dehydrated in 70%, 95% and 100% ethanol, and cleared in methyl salicylate. Using a Leitz Aristoplan microscope, cells were drawn through a camera lucida and photographed.

I also backfilled six N1PV nerves distal to the merus-carpus joint in *B. occidentalis*. These fills omitted the accessory flexor excitor motor neuron (aFE) from the N1PV fills, so I were able to pinpoint the location of the aFE in the proximally-filled preparations by its absence in these distal fills. The procedure was the same as more proximal fills except that fills were left for about 40 hours.

Results

I first describe reductor muscle innervation, because interpreting the rest of the data is difficult without it. Then, I compare the number, position, exit routes of the axons, and morphology of the motor neurons for all four species. Finally, I present some information on putative non-motor neurons, because these data may help explain discrepancies between previous studies (Table 6.1).

The reductor muscle is triply innervated

B. occidentalis and *E. analoga* were the most suitable subjects for examining the reductor innervation because of their legs' thickness; 36 reductor muscles were stained in *B. occidentalis*, and 10 were stained in *E. analoga*. The reductor was also stained in one claw in *M. quadrispina* and three claws in *P. leniusculus*. I saw three axons branching out over the reductor muscle in over half the preparations (31 of 50; Figure 6.1E). Most of the remaining preparations (18 of 43) showed one or two axons, which is typical of methylene blue's capriciousness. Four axons appeared to stain in two cases, but I can not rule out the possibility that one of the reductor axons bifurcated soon after exiting the main nerve. The rarity of this observation plus the fact that no other distal leg muscle is known to be quadruply innervated makes it most likely that three axons innervate the reductor [see also Silvey 1981; Wiens 1993]. Given the limitations of methylene blue, however, other reductor axons may remain undetected [Parsons 1982].

In some preparations (Figure 6.1F), it was possible to see where the motor axons left N1AV. One axon branches at that junction, with one branch leading to the reductor and the other continuing to the more distal part of the leg. This neuron is probably the common inhibitor (CI) [Cooke & Macmillan 1983; Rathmayer & Bévangut 1986; Wiens et al. 1988]. One of the other two axons is approximately the same size as the putative CI while the other is consistently smaller. By comparison with other triply innervated leg muscles (the bender, closer, and extensor are all innervated by CI, a fast excitor, and a slow excitor), these non-branching axons are probably a fast reductor excitor (FRE_?; question mark indicates tentative identification) and a slow reductor excitor (SRE_?), with SRE being the smaller.

Somata locations and axons' exit routes

Based on Wiersma and Ripley [1952], Wiens [1989, 1993], and the evidence of the reductor's triple innervation [above; also Silvey 1981; Wiens 1993], seventeen motor neurons should be revealed by backfills, if the distal leg motor neurons have been conserved. These would be the common inhibitor (CI), the stretcher inhibitor (SI), the opener inhibitor (OI), the fast and slow excitors to the closer (FCE, SCE), bender (FBE, SBE), extensor (FEE, SEE), and reductor (FRE, SRE), four flexor excitors (FE_α, FE_β, FE_γ, and FE_ρ) [see Wiens et al. 1991, for nomenclature], one accessory flexor excitor (aFE), and one excitor shared between the opener and stretcher (OE≡SE).

I successfully backfilled fourteen, fourteen, and six N1AV nerves and eighteen, thirty-one, and twenty-five N1PV nerves in *B. occidentalis*, *M. quadrispina*, and *P. leniusculus*, respectively, and six N1PV nerves just distal to the merus-carpus joint in *B. occidentalis*. Thirty-nine N1(A+P)V nerves of *E. analoga* were successfully filled.

I found seventeen motor neuron somata in *M. quadrispina*, sixteen in *B. occidentalis*, and fifteen in *E. analoga* and *P. leniusculus* (Figure 6.1). Because backfills are often incomplete, and distinguishing small cell bodies in tightly clustered groups of cell bodies can be difficult, it is easy to explain finding fewer cells than expected. It is far more difficult to explain reports of more cells than expected, which is the case in three of the

four studies mapping distal leg motor neurons (Table 6.1). There are several possible explanations. In one case, nerves to the proximal muscles were probably filled along with N1AV and N1PV [Wilson & Sherman 1975]. As for the others [Chrachri & Clarac 1989; Wiens & Wolf 1993], there may be as yet undescribed motor neurons in some species, but the strong similarity of peripheral innervation in the reptantians studied makes this the least likely explanation. Alternately, there may be non-motor neurons whose axons project out the distal leg nerves, such as neurosecretory cells (see below) or stretch receptors. Some stretch receptors have a motor neuron-like structure with a central soma and are found in the same general location as motor neurons [Bush 1981; Paul 1972; Paul & Wilson 1994]. To date, however, there has been no suggestion that there are any such stretch receptors in the distal leg.

The cell bodies of the distal leg motor neurons are located in four groups within the hemiganglion (Figure 6.2). The physiological identification of some of these cells in other studies, mainly on astacideans [Govind & Lang 1981; Silvey 1981; Wiens 1976, 1989, 1993; Wiens & Wolf 1993; Wiersma & Ripley 1952] enabled me to posit functions for most of the neurons filled in this study on the premise that similarities of soma positions and major dendritic processes provide good evidence for the homology of the cells [Arbas et al. 1991; Paul 1989, 1991; Sillar & Heitler 1985]. Two cells, CI and SI, are caudal along the midline [described in three crayfish species: Wiens & Wolf 1993; also Bévengut et al. 1995]. The common inhibitor is slightly more caudal than SI and located just across the midline in the contralateral hemiganglion (Figure 6.1). A large cluster of excitators is located in the anterior-lateral region of the ganglion: OE \equiv SE, two CEs [*H. americanus*: Govind & Lang 1981; *Procambarus clarkii*: Wiens 1976], the four FEs [*J. novaehollandiae*: Silvey 1981], two EEs, two REs, and one BE, which I term BE $_{\alpha}$ (see section on *B. occidentalis* below). Two cells are found posterior to the base of N1PV, along the lateral margin of the ganglion, in about the same dorso-ventral plane or slightly ventral to the anterior cluster and medial pair: OI [Wiens 1976] and a second BE, which I term BE $_{\beta}$. Finally, there is a third cell, which is also posterior-lateral, but is consistently

more dorsal in the ganglion than the other pair of posterior-lateral somata: aFE (Figure 6.1A, C, D).

Figure 6.1: Photographs of distal leg motor neurons

Examples of distal leg motor neurons in different species. (A) Photograph of combined fill of N1AV and N1PV in T4 of *B. occidentalis*. Arrow “aFE” points to the cell body of the accessory flexor excitor (aFE), which is more dorsal than the other two posterior-lateral motor neurons. “CI” and “SI” arrows show cell bodies of common inhibitor and stretcher inhibitor, respectively. (B) N1AV fill in T4 of *B. occidentalis*. Arrow indicates CI, slightly out of focus. Asterisk marks axon of putative non-motor neuron (see Figure 6.5), possibly from the sand crab homologue of the cuticular stress detector 1 sense organ [Marchand et al. 1995]. (C) N1PV fill in T3 of *B. occidentalis*. aFE cell body out of focus due to its more dorsal position in ganglion. (D) N1PV fill in T7 of *P. leniusculus*. Four anterior-lateral cells fill in this species compared to only three in *B. occidentalis*. Arrow “SI” shows SI axon projecting toward middle of ganglion (soma off-frame). Inset: detail of posterior-lateral trio of cells, photographed at more dorsal focal plane, with aFE indicated; this cell is also drawn in Figure 6.3D. (E) The three axons innervating the reductor muscle of *B. occidentalis* stained with reduced methylene blue. (F) Drawing of reductor nerve branching from the distal leg nerve in *E. analoga*, stained with reduced methylene blue. Bifurcating axon belongs to putative CI. Dots indicate outline of nerve. Anterior is towards top of page in this and next figures. Scale bars = 200 μm (A–D, shown in F), ~140 μm (E, shown in F), and ~750 μm (F).

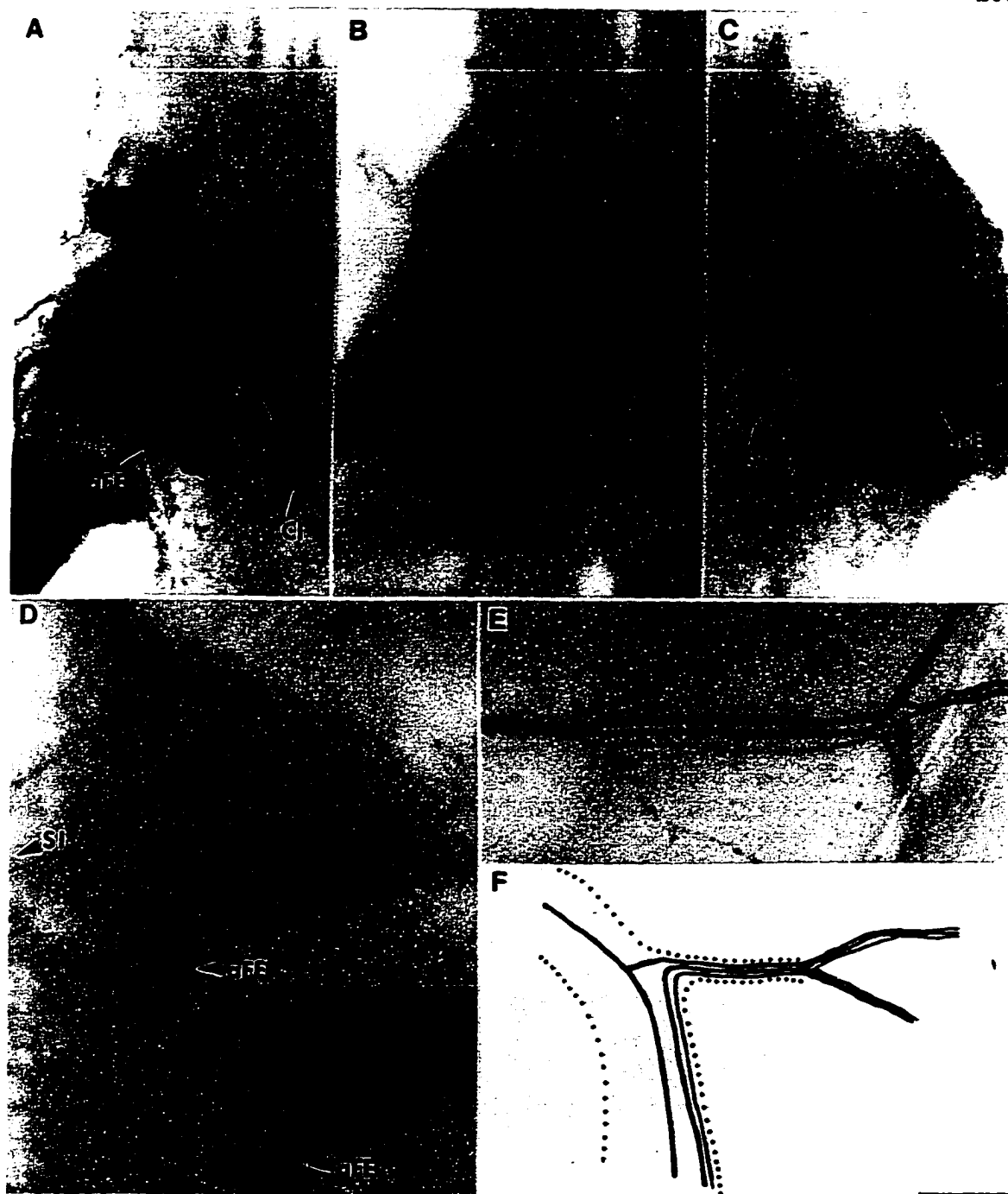
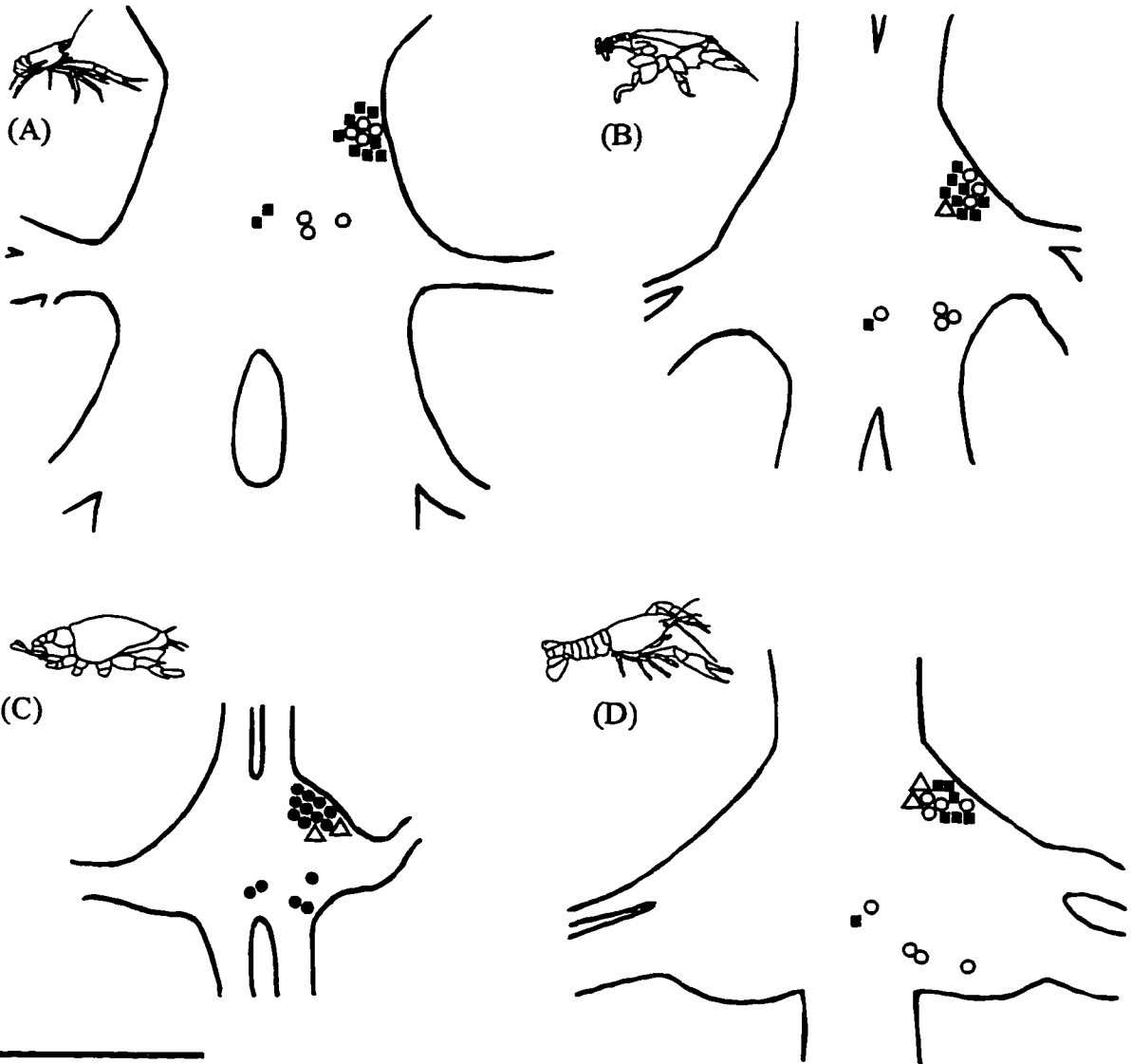


Figure 6.2: Maps of distal leg motor neurons.

Composite maps of motor neurons somata in T5 of (A) *M. quadrispina*, (B) *B. occidentalis*, (C) *E. analoga* and (D) *P. leniusculus*. The organisation of leg motor neurons within the ganglia is basically the same for all legs examined [but compare with Figure 2F in Silvey 1981]. ■ - neurons whose axons exit the ganglion by N1AV; ○ - N1PV; ● - N1(A+P)V; triangles indicate cells whose presence is predicted, but which could not be distinguished with certainty. Scale bar = 1 mm (shown in C, same for A, B, and D).



Munida quadrispina

Backfills of N1AV in *M. quadrispina* (Figure 6.2A, Table 6.2) revealed a maximum of ten motor neurons: CI, SI, OE \equiv SE, the four FEs, FEE [Wiersma & Ripley 1952], and REs (see above). Two somata are posterior-medial. Their placement and morphology suggest that they are CI and SI, which have been identified in crayfish [Wiens & Wolf 1993; Bévengut et al. 1995]. Eight somata could be distinguished in the anterior-lateral area of the ganglion (Figure 6.2A).

Seven motor neurons filled from N1PV (Figure 6.2A, Table 6.2). In contrast, Wiersma and Ripley [1952] found that N1PV contained six axons in hermit crabs: OI, aFE, CEs and BEs. I predict that the seventh cell filled by N1PV is SEE, because both the position and number of motor neuron somata filling through N1PV in *M. quadrispina* is the same as in *P. leniusculus* (see below), except that the easily identifiable SI exits via N1AV in *M. quadrispina* and N1PV in *P. leniusculus* (Figure 6.3).

Four somata are in the anterior-lateral portion of the ganglion (*contra* findings in *P. clarkii* [Chrachri & Clarac 1989] but in agreement with other findings in *P. clarkii* and *H. americanus* [Govind & Lang 1981; Wiens 1976; Wilson & Sherman 1975]), and three somata are posterior-lateral, with one soma more dorsal than the others. Two of the cells located anterior-laterally are presumably the two CEs [Govind & Lang 1981; Wiens 1976], and one of the cells located posterior-laterally is presumably OI [Wiens 1976]. The identities of the remaining cell bodies — two anterior and two posterior — were largely resolved by results from fills of N1PV in *B. occidentalis*.

Table 6.2: Leg motor neuron exit routes

Comparison of axonal exit routes in the four species studied. Note that in two anomurans (*M. quadrispina* and *B. occidentalis*), the exit routes differ from each other and from that described for hermit crabs, the remaining Anomuran superfamily [Wiersma & Ripley 1952]. Symbols: ■ = N1AV; ○ = N1PV; ● = N1(A+P)V (Same as in Figure 6.2).

Table 6.2

Species	Inhibitors			Exciters							
	CI	SI	OI	OE=SE	CEs	BEs	FEs	aFE	FEE	SEE	REs
<i>M. quadrispina</i>	■	■	○	■	○	○	■	○	■	○	■
<i>B. occidentalis</i>	■	○	○	■	○	○	■	○	■	■	■
<i>E. analoga</i>	●	●	●	●	●	●	●	●	●	●	●
<i>P. leniusculus</i>	■	○	○	■	○	○	■	○	■	○	■

Blepharipoda occidentalis

A total of sixteen somata were filled in *B. occidentalis*, with one anterior-lateral cell body fewer than expected. The close agreement with the number expected makes an early claim that *B. occidentalis* has more leg motor neurons than other decapods [van Harreveld 1939] implausible. The probable explanation for this small discrepancy in cell numbers is that one cell body in the tightly clustered anterior group was concealed by the other somata and not counted. Alternately, fills of either nerve may not have been complete. Several N1PV fills were of very high quality, however, with little background staining or obvious swelling, so I am confident that I obtained complete fills from N1PV, which show three anterior-lateral somata. Therefore, if there is a cell body I failed to resolve, its axon would exit through N1AV.

There are two differences in the locations and exit routes of motor neurons in *B. occidentalis* and *M. quadrispina* (Figure 6.2B, Table 6.2). First, SI exits via N1PV in *B. occidentalis*. Second, only three anterior-lateral cells fill through N1PV. By analogy with hermit crabs [Wiersma & Ripley 1952], I suggest that the excitor tentatively identified as SEE in *M. quadrispina* (above) exits through N1AV rather than N1PV.

To determine the locations of aFE, FBE and SBE, I filled N1PV distal to the merus-carpus joint, thus omitting aFE from the fill. The posterior-lateral-dorsal cell was missing from these fills, indicating that it is aFE. Thus, FBE and SBE are located in different groups in the ganglia: one is located in the anterior-lateral cluster, and the other is posterior-lateral-ventral, paired with OI. Physiological studies are needed to show which cell is FBE and which is SBE. I suggest the anterior-lateral BE be called BE_α (mnemonic: “α” for “anterior”), and the posterior-lateral BE called BE_β (mnemonic: “β” for “back”) until their identities can be determined using intracellular recording.

Lepidopa californica

L. californica has at least four distal leg nerves. No other species examined to date has such a profusion of branches to the distal leg. Too few individuals were available to

firmly establish the locations of many cell bodies, but it appears that there is at least one medially located soma and an anterior-lateral pair. This small amount of data is consistent with that gathered in the other four species.

Emerita analoga

Like some brachyuran crabs [Wiersma & Ripley 1952; but see Bévangut et al. 1983], the distal leg nerve in *E. analoga* does not separate into anterior & posterior branches. I term it NI(A+P)V to emphasise its homology with the N1AV and N1PV of the other three species studied. A total of fifteen cells were counted in *E. analoga*, two fewer than expected (Figure 6.2C). As in the other species, two cells are posterior-medial (CI and SI), two cells are posterior-lateral-ventral (OI and BE_p), one cell is posterior-lateral dorsal (aFE), and a tight cluster of at least ten cells (the maximum number individually distinguishable) are anterior-lateral. Resolving individual somata in this anterior-lateral group is even more difficult in *E. analoga* than in the other species, because the three or four anterior-lateral neurons that project their axons out the N1PV in the other three species studied cannot be omitted from fills in *E. analoga*.

Pacifastacus leniusculus

Fifteen somata, two fewer than expected from studies at the periphery [Wiens 1993], are located in the same positions in *P. leniusculus* as in the anomurans (Figure 6.2D): two medial (CI and SI), two posterior-lateral-ventral (OI and BE_p), one posterior-lateral-dorsal (aFE), and a maximum of ten cells that could be distinguished in a group of anterior-lateral excitors. Although an "additional" anterior-medial cell body has been found in two other astacideans (see above), I found no evidence for such a cell in *P. leniusculus*.

In *P. leniusculus*, N1AV contains nine axons [Wiens 1993]: the medial CI and the anterior-lateral OE≡SE, FEs, REs, and FEE (Table 6.2). A maximum of six somata were visible in the anterior-lateral cluster of cells filled by N1AV, two fewer than the expected eight. This discrepancy in cell numbers may be because the quality of *P. leniusculus*

backfills was usually poorer than the backfills of N1 in the three marine species, making resolution of individual, closely packed somata problematic.

I got complete fills showing the eight neurons contained in N1PV [Wiens 1993]: SI, OI, CEs, BEs, SEE, and aFE (Figure 6.1D, Figure 6.2D, Table 6.2); SI is clearly recognisable by its typical posterior-medial location [Wiens & Wolf 1993].

Cell morphology

The neurites of the distal leg motor neurons are confined to the ipsilateral hemiganglion (Figure 6.1A, Figure 6.3). Neurites crossed the midline in only two fills and did not project any significant distance into the contralateral hemiganglion; in fact, these processes may not have belonged to motor neurons (see Non-motor cells: 225). Somata diameters range from ~40-100 μm in all four species, even though the overall size of the thoracic ganglia in *E. analoga* is considerably smaller than in *B. occidentalis* and *P. leniusculus* (Figure 6.2). This is within the range of sizes previously reported for leg motor neurons in other species [Bévengut et al. 1983; Silvey 1981; Skorupski & Sillar 1988; Wiens 1976].

Although I have identified the locations of the leg motor neuron somata, I could generally not identify cells within a cluster. The only cells which could be recognised consistently were CI, SI [Wiens & Wolf 1993], and aFE, due to their solitary locations apart from other motor neurons. The excitor shared by the opener and stretcher was identified in *B. occidentalis* in two "distal to merus" fills used to determine the location of aFE.

The structures of CI and SI in the four species studied are, for all practical purposes, identical to the descriptions of Wiens and Wolf [1993]: the neurites of both cells project rostrally before making a lateral turn (with SI tending to make a sharper turn than CI) toward N1 and leaving the ganglion (Figure 6.3A). The common inhibitor had a larger diameter soma (~100 μm) than SI (~50 μm) in *P. leniusculus*, but the two cells are almost the same size in the three anomuran species, with CI tending to be just slightly larger

(Figure 6.1A, Figure 6.3A). The common inhibitor is often just contralateral (Figure 6.3A, B), or at least closer to the midline than SI (Figure 6.3B).

The main neurite of aFE projects rostrally, then turns laterally, with one rostrally directed neurite at that branch point (Figure 6.4). The aFE cell body is often, but not always, medial relative to the OI and BE_{β} cell bodies. Interestingly, the aFE cell body is not smaller than other neurons, even though the accessory flexor is much smaller than other distal leg muscles.

The structure of $OE \equiv SE$ in *B. occidentalis* is similar to its homologue in *P. clarkii*, with one major neurite projecting caudally [Wiens 1976]. The opener/stretcher excitor is located more laterally in the ganglion than the CEs [in agreement with Govind & Lang 1981; Wiens 1976] and BE_{α} . I could not determine the relative placement of BE_{α} in relation to the CEs.

Figure 6.3: Position of CI

Camera lucida drawing of cells in the ganglion filled through N1AV in (A) T4 of *M. quadrispina*, showing both CI and SI filling via this nerve; (B) T5 in *B. occidentalis* ganglion with bilateral N1AV fills, showing that CI soma is slightly contralateral. Axons of the two CIs cross each other. Compare with Figure 6.1B. Dashed line in *A* indicates midline. Ganglion in *B* distorted during fixation and intensification. Scale bars = 200 μm .

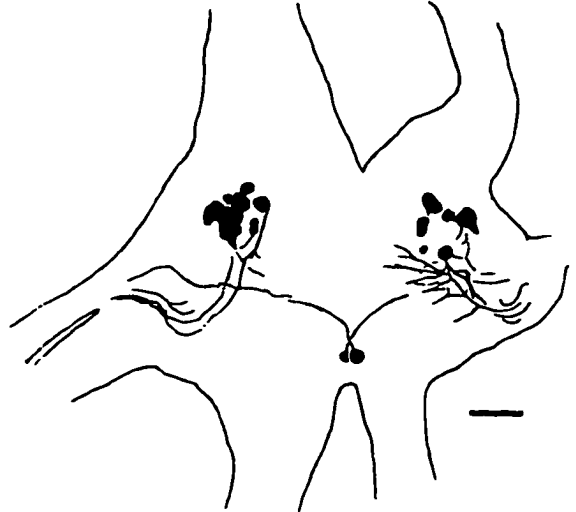
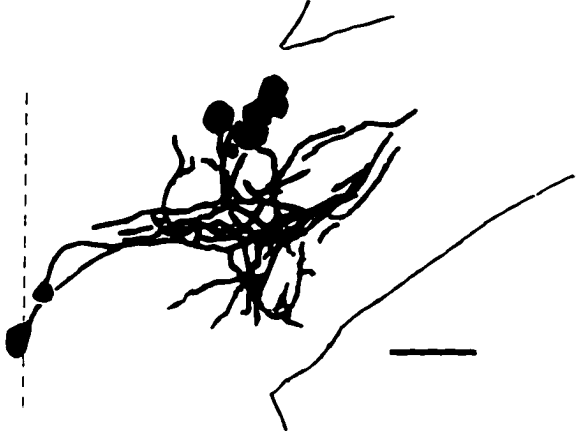
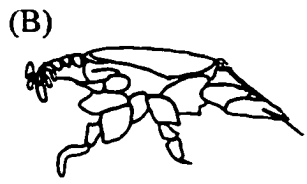
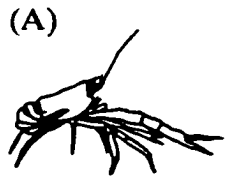
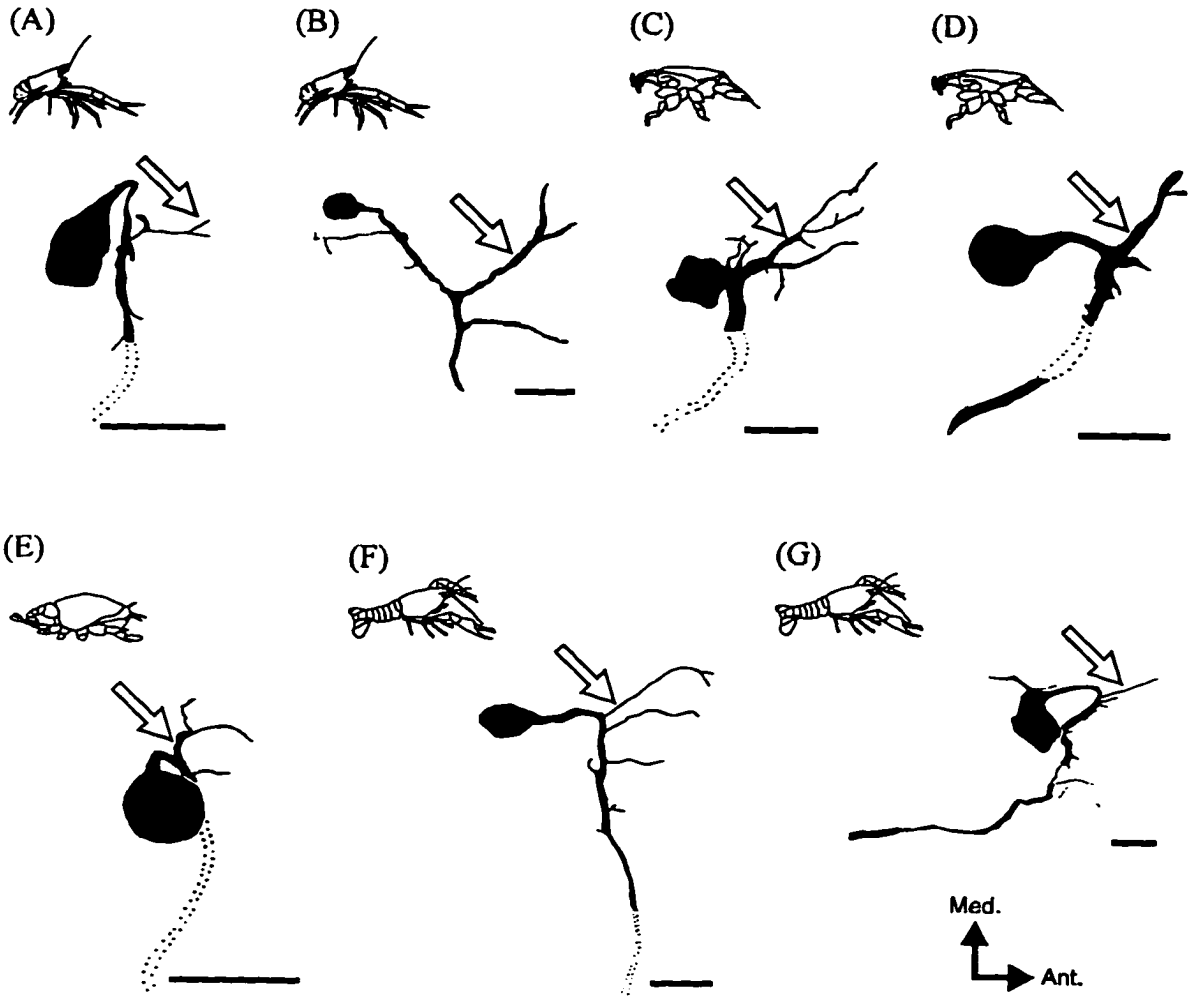


Figure 6.4: Morphology of aFE motor neuron

Camera lucida drawings of accessory flexor excitor in (A) T6 and (B) T4 of *M. quadrispina*, (C) T5 and (D) T4 of *B. occidentalis*, (E) T5 of *E. analoga* and (F) T7 and (G) T8 of *P. leniusculus*. The rostrally projecting neurite (arrow) is the most characteristic feature of this cell other than its comparatively dorsal location. Dotted lines indicate processes partially obscured by other material in the ganglion. Arrows indicate orientation of cells in ganglion; Med. = medial, Ant. = anterior. Scale bars = 100 μm .



Non-motor neurons

Some cells fill through N1 that are morphologically unlike leg motor neurons, in that their processes span multiple ganglia, they have peripheral axons in more than one segment, and their somata are well removed from the clusters of motor neuron cell bodies. A complete description of this heterogeneous group of putative non-motor cells is outside the scope of this chapter, but I have included these data because they may partly explain the discrepancies between the numbers of axons reported at the periphery and the number of somata reported centrally (Table 6.1). The following description is based primarily on *M. quadrispina* fills, because the thoracic ganglia were not separated during dissection, as was done for the other species.

The non-motor cells stain very faintly compared to motor neurons filled simultaneously. Their morphology seems to vary from ganglion to ganglion, so that there does not seem to be a group of serially homologous cells present in all leg ganglia. In *P. leniusculus*, *M. quadrispina*, and *B. occidentalis*, at least two axons fill though N1AV and two fill through N1PV. In *E. analoga*, I could not ascertain the exact number of these axons filled via N1(A+P)V, but there are clearly more than two. These non-motor cells have central axons which either ascend (e.g., Figure 6.1B), descend, or bifurcate, with one rostral and one caudal branch in the ganglion from which their peripheral axons were backfilled. Some of these cells have long central processes: in *M. quadrispina*, at least one axon runs from T4, into the abdominal nerve cord, and past the first abdominal ganglion (A1); it gives off processes in all the leg ganglia which, in at least T4-6 (Figure 6.5), exit to the periphery. Their cell bodies in *M. quadrispina* are located between the main neuropilar areas of adjacent ganglia; no cell bodies have yet been found in contralateral hemiganglia. Somata placement in species with unfused ganglia is not clear, but cell bodies may be located within the same hemiganglion of the filled nerve or within ipsilateral hemiganglia distant from the filled nerve.

Figure 6.5: Putative neurosecretory cells

Camera lucida drawing of T4-8 in *M. quadrispina* showing putative neurosecretory cells filled via NIPV of T4 (solid arrow); the same two cells have also been filled through NIPV in T5 and T6 (open arrows), and could probably be filled through NIPV in T7 and T8. Only one non-motor cell body was visible in this particular fill (between T6 and T7), but a soma in T4 (dashed line and circle) has filled through NIPV in several other specimens. Dots indicate places where neurite filling was faint. Dashed lines indicates neuropilar areas of T4-8. Additional motor neuron somata filled simultaneously in T4 are shown (see Figure 6.1). SA: Sinus arteriosus. Scale bar = 1 mm.



Discussion

Since there are descriptions of the innervation of all distal leg muscles in species representing most major subdivisions of the Reptantia, and evidence for approximately equal numbers of cell bodies and peripheral motor axons, there is a nearly complete ground plan of reptantian decapod leg innervation (Figure 6.6). Each distal leg muscle is innervated by up to five neurons, whereas each proximal muscle is innervated by a larger “pool” of excitors plus the common inhibitor. The exact number of proximal motor neurons has not been fully worked out, and it may be that the number of proximal leg motor neurons is more variable across taxa than the number of distal leg motor neurons.

The evidence that the reductor is innervated by at least (and perhaps no more than) three neurons (tentatively identified as two putative excitors and CI) fits with an “excitor doubling” hypothesis concerning the flexor muscle: Wiens et al. [1991] hypothesised that the quintuply-innervated flexor was originally innervated by two excitors, and that the number of excitors was ontogenetically doubled during evolution. Four distal leg muscles (the closer, bender, extensor, and reductor) appear to be innervated by CI and two excitors, suggesting that this is the leg muscles’ basic innervation scheme. The opener and stretcher muscles might also represent evolutionary deviations from triple innervation.

Figure 6.6: Typical reptantian leg innervation

The usual peripheral innervation of reptantian legs. The number of proximal leg motor neurons reported has varied [*P. clarkii*, levator and depressor: El Manira et al. 1991a; promotor and remotor: El Manira et al. 1991b; all proximal muscles, Pearlstein et al. 1995; *P. leniusculus*, promotor and combination of remotor and depressor: Skorupski & Sillar 1988; *C. maenas*, all proximal muscles: Bévangut et al. 1983; levator, Moffett et al. 1987]; consequently, the estimated total number of leg motor neurons is between 51 and 81. The only identified proximal muscle excitor is a promotor motor neuron in *P. leniusculus* that receives direct input from the medial giant interneuron [Heitler & Fraser 1989]. The following species variations in the number of target muscles innervated by particular neurons are omitted for clarity. In *P. leniusculus*, SI innervates the closer [Wiens 1991, 1993]. The flexor excitators are shared between the flexor and the accessory flexor muscles in some species [Govind & Wiens 1985; Parsons 1982]. Similarly, the rotator, an additional muscle in *H. americanus*, has FE_p as its sole excitor [Wiens & Govind 1990]. Palinurans may lack OI (see text). Boxes represent muscles (distal at top): O = opener; C = closer; S = stretcher; B = bender; E = extensor; F = flexor; aF = accessory flexor; Rd = reductor; L = levator; D = depressor; P = promotor; R = remotor. Triangles represent excitatory synapses; circles, inhibitory synapses; ovals, pools of unidentified motor neurons.

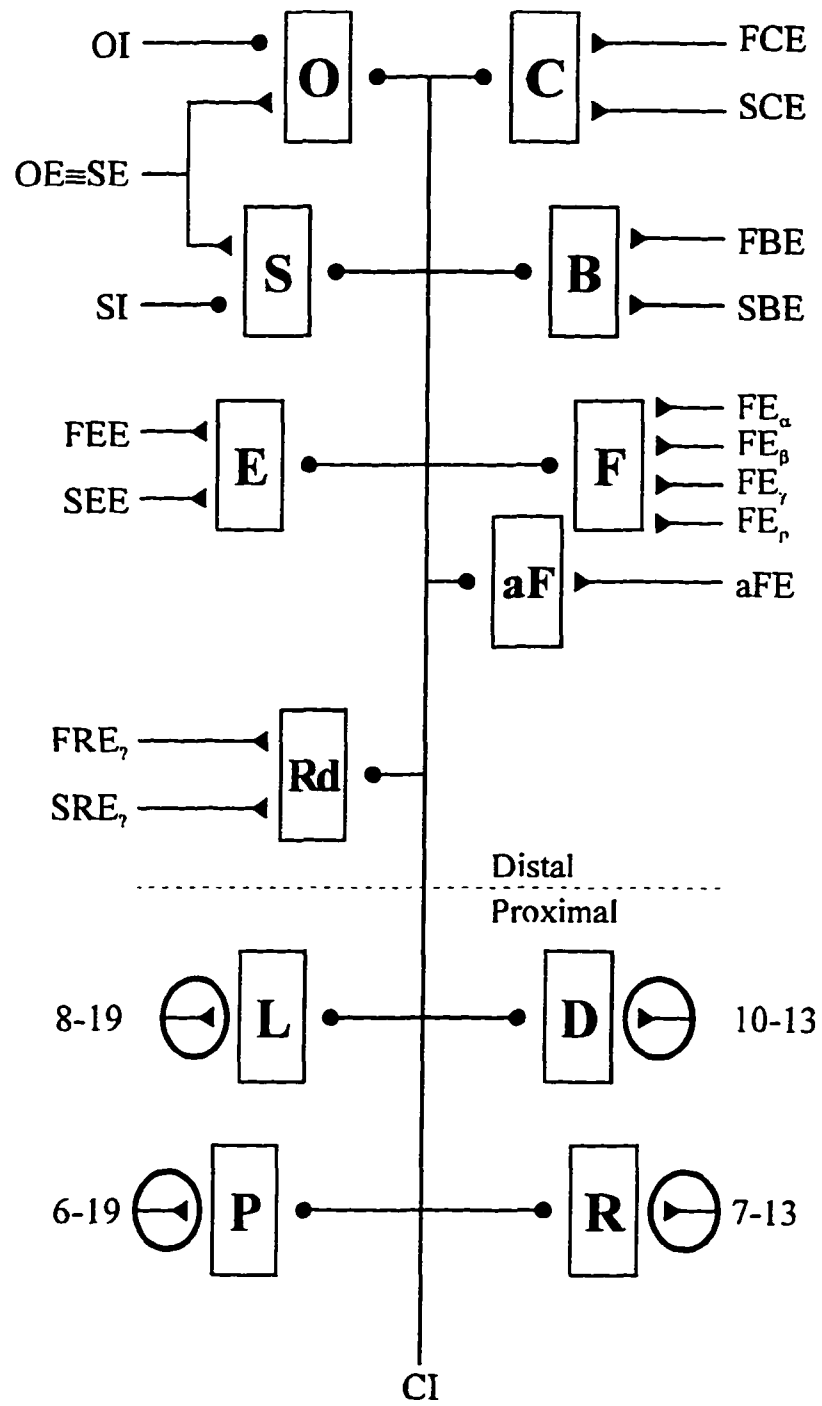


Table 6.3: Summary of leg motor neuron location and and exit routes

Central locations of distal leg somata and axonal exit routes. Location of distal leg motor neuron somata and comparison of their axonal projections in Anomura and Astacidae.

Species listed under “Soma location” indicate cases where cells have been identified physiologically. The information on axonal exit routes represents a consensus from this study and Wiersma and Ripley [1952] except for cases of noted species differences. Note that SI has been reported to exit both by NIAV and NIPV in *P. clarkii*. Reference abbreviations: (1) Bévengut et al. 1983; (2) Bévengut et al. 1995; (3) this study; (4) Govind & Lang 1981; (5) Moffett et al. 1987; (6) Wiens 1976; (7) Wiens 1993; (8) Wiens & Wolf 1993; (9) Wiersma 1941; (10) Wiersma & Ripley 1952.

Table 6.3

Neuron	Soma location	Axon exit route
CI	Posterior-medial, just contralateral, posterior to SI <i>P. clarkii</i> ^{2,8} , <i>O. limosus</i> ⁸ , <i>P. leniusculus</i> ⁸ , <i>C. maenas</i> _{1,5}	NIAV
SI	Posterior-medial, anterior to CI <i>P. clarkii</i> ⁸ , <i>O. limosus</i> ⁸ , <i>P. leniusculus</i> ⁸	NIAV: <i>D. asper</i> ¹⁰ , <i>M. quadrispina</i> ³ , <i>P. clarkii</i> ⁹ NIPV: <i>B. occidentalis</i> ³ , <i>P. clarkii</i> ⁸ , <i>O. limosus</i> ⁸ , <i>P. leniusculus</i> ⁸
OI	Posterior-lateral, close to BE _β , ventral to aFE <i>P. clarkii</i> ^{6,8} , <i>O. limosus</i> ⁸ , <i>P. leniusculus</i> ⁸	NIPV
OE=SE	Anterior-lateral, lateral to CEs and BE _α <i>H. americanus</i> ⁴ , <i>P. clarkii</i> ⁶	NIAV
FCE	Anterior-lateral; medial to OE=SE <i>H. americanus</i> ⁴ , <i>P. clarkii</i> ⁶	NIPV
SCE	Anterior-lateral; medial to OE=SE <i>H. americanus</i> ⁴ , <i>P. clarkii</i> ⁶	NIPV
BE _α	Anterior-lateral, medial to OE=SE	NIPV
BE _β	Posterior-lateral, ventral to aFE, close to OI	NIPV
FE _α	Anterior-lateral	NIAV
FE _β	Anterior-lateral	NIAV
FE _γ	Anterior-lateral	NIAV
FE _ρ	Anterior-lateral	NIAV
aFE	Posterior-lateral, dorsal and lateral to OI and BE _β	NIPV

(Continued on next page)

Table 6.3 (Continued)

FEE	Anterior-lateral	NIAV: <i>D. asper</i> ¹⁰ , <i>M. quadrispina</i> ³ , <i>B. occidentalis</i> ³ , <i>P. leniusculus</i> ^{3,7} NIPV: <i>P. clarkii</i> ⁹
SEE	Anterior-lateral	NIAV: <i>D. asper</i> ¹⁰ , <i>B. occidentalis</i> ³ NIPV: <i>M. quadrispina</i> ³ , <i>P. clarkii</i> ⁹ , <i>P. leniusculus</i> ^{3,7}
FRE	Anterior-lateral	NIAV: <i>P. leniusculus</i> ⁷
SRE	Anterior-lateral	NIAV: <i>P. leniusculus</i> ⁷

The nerve through which the axons exit the ganglion can vary within an infraorder (Table 6.2, Table 6.3). For example, in anomurans, the SI axon exits via N1PV in *B. occidentalis*, N1AV in *M. quadrispina* and the hermit crabs studied [Wiersma & Ripley 1952]. Similarly, the extensor excitators in *P. leniusculus* and *M. quadrispina* exit the ganglia by separate nerves, but they do not do so in *B. occidentalis* or *J. novaehollandiae* [Silvey 1981]. Finally, the number of branches in the nerve to the distal leg varies between genera: the distal leg is supplied with one nerve in *E. analoga*, two in *B. occidentalis*, and at least four in pearly sand crabs, *L. californica* (Hippoidea: Albuneidae). The variation in axon pathways in this and other studies does not correspond in a simple way to hypothesised phylogenies of the taxa (Schram 1986). This suggests either that particular neurons have independently converged to have the same exit route in different taxa, or that axonal pathways have “flip-flopped” between possible exit routes over evolutionary time. Such variability is not surprising, because there is no functional advantage for an axon to exit the ganglion by a particular nerve if more than one nerve targets the same general area (i.e., the distal leg muscles). The variability in exit routes is evidence against the hypothesis that the separate exits of the extensor excitators through N1AV and N1PV in *P. leniusculus* and the separate exits of the tibia extensor excitators in locusts are homologous [Wiens 1993]. Such variability in axonal exit routes may also explain a posterior-lateral soma filled from N1AV in *P. clarkii* [Chrachri & Clarac 1989] that has not been seen in other species: it could be that OI, BE_β, or aFE exit via N1AV in *P. clarkii*, although I never observed such an exit route in the species I studied.

One goal of this project was to see if any anatomical features suggested hypotheses about the physiological connections between neurons. The opener inhibitor and BE_β have their somata positioned close together, but more interestingly, some of their fine processes are in close proximity to each other (e.g., Figure 6.1A), suggesting that these cells could synapse on each other, as OI synapses onto OE≡SE and the CEs [Wiens & Atwood 1978]. It would make functional sense for OI to inhibit BE_β. Consider a situation when an animal “wants” to contract the stretcher muscle (thereby moving its carpus-propus joint) without contracting the opener muscle (holding the propus-dactyl joint still). Contracting

just the stretcher muscle will require inhibiting the opener (by firing OI), because the stretcher and opener muscles share a single excitor, $OE \equiv SE$. Because the bender is the stretcher's antagonist, preventing the bender from contracting could be accomplished in part by directly inhibiting BE_{β} .

Legs and swimmerets

There is a very gross similarity between the location and number of thoracic leg motor neurons and the segmentally homologous abdominal swimmeret motor neurons. In both, cell bodies are grouped in an anterior-lateral cluster, a posterior-lateral cluster, plus a few medial cells; in *H. americanus*, one medially placed swimmeret motor neuron is a common inhibitor [Davis 1971].

One difference between the structure of thoracic and abdominal limb motor neurons is that the processes of the leg motor neurons are confined to the ipsilateral hemiganglion, whereas some swimmeret motor neurons send processes across the midline to the contralateral hemiganglion [Heitler & Darrig 1986; Paul & Mulloney 1985]. Contralateral legs normally alternate their forward and backward movements during walking [Clarac 1984; Cruse 1990; Jamon & Clarac 1995; Müller & Cruse 1991], but contralateral swimmerets usually beat synchronously. The contralateral projections of swimmeret motor neurons may facilitate synchronous swimmeret beating [Paul & Mulloney 1985].

There appear to be approximately the same number of thoracic leg motor neurons (51-81) as there are swimmeret motor neurons [68 in *P. leniusculus*; Mulloney et al. 1991], so about the same number of motor neurons are used to control a six-jointed leg as a three-jointed swimmeret. The greater "computational" requirements of controlling the larger number of joints and muscles in the leg compared to the swimmeret may partly explain why the neuropil involved with the limbs is much larger in the thoracic ganglia relative to the segmentally homologous regions in abdominal ganglia [Elson 1995].

Non-motor cells

The anatomy of some of the non-motor cells filled during this study suggests they might be neurosecretory. Proctolinergic cells have axons projecting out N1 in *H. americanus* and *P. clarkii* [Siwicki & Bishop 1986], some octopaminergic neurons have axons projecting to the distal portion of the claw in *H. americanus* [Schneider et al. 1995], and putative neurosecretory axons with “strap-like” endings have been found in the closer muscle of *Carcinus* spp. crabs [Huddart & Bradbury 1972]. The morphology of individual proctolinergic cells has not been described, but the morphology of some of the non-motor N1 cells described here (Figure 6.5) resemble serotonergic-proctolinergic cells [Beltz & Kravitz 1987]: both have processes spanning and sending axons out the nerves of multiple thoracic ganglia. Unlike the cells here, serotonin-proctolin cells exit via the second nerve (N2) rather than N1 [Beltz & Kravitz 1987], and the locations of serotonin-immunoreactive cell bodies in *M. quadrispina* do not correspond with the location of the cell bodies I have filled [B.L. Antonsen & D.H. Paul, unpublished observations].

Do palimurans have different leg motor neurons?

This study helps to clarify apparent differences between species in which the central properties of distal leg motor neurons have been examined. My data suggests that the large number of cell bodies (31-37) found by Wilson and Sherman [1975] was, as they thought, due to proximal leg nerves being inadvertently filled with the distal ones. The anterior-medial cell body reported in some astacideans [Wilson & Sherman 1975; Wiens & Wolf 1993] may belong to a non-motor neuron, possibly neurosecretory (above). It is difficult, however, to reconcile the description of distal leg motor neurons from Chrachri and Clarac [1989] with ours and other published results (Table 6.1), even with the possibility that non-motor neurons may inflate estimates of motor neuron somata number. Finally, Silvey's data [1981] on the distal leg motor neurons of southern rock lobsters, *Jasus novaehollandiae*, are sufficiently detailed to warrant re-examination in light of evidence from this and other studies.

Wiersma and Ripley [1952] described 14 axons at the periphery in two palinuran species and found no specific OI. Assuming that the palinuran reductor muscle is innervated by two excitors (see above), the total number of cells expected is sixteen, exactly what Silvey [1981] found in electron micrograph sections of leg nerves. Thus, there is no evidence from previous studies that palinurans have OI. Because palinuran and astacidean leg skeletal-musculature is generally similar [Clarac 1984; Wiersma & Ripley 1952], the lack of OI would be expected to have significant consequences for palinuran motor control. In all other reptantians, OI and SI allow the jointly excited opener and stretcher muscles to contract independently. If palinurans lack OI, then whenever they contract the stretcher to move the propus, they must simultaneously contract the opener and move the dactyl. A speculative reason why palinurans may be able to tolerate the predicted deficit in fine control of the leg is that palinurans have no claws or chelate legs (i.e., with small claws capable of grasping). Using claws requires the ability to place the claw in a precise location (i.e., a vulnerable part of the attacker); conversely, the unspecialised legs of palinurans act mainly as struts during walking [Clarac 1984]. Thus, the independent control of every leg joint (partly provided by OI) may be at a higher premium in clawed animals than those without claws. This may initially seem implausible considering how similar palinurans are to other decapods in their peripheral leg motor neuron complement, but more discrepancies emerge when comparing the motor neuron cell bodies across taxa.

Silvey [1981] found only one midline cell, not two (CI and SI) as I and others [Wiens & Wolf 1993] found in non-palinurans. The one medial cell is probably CI, because its axon exits via N1PV, whereas SI exits by N1AV [Wiersma & Ripley 1952]. The stretcher inhibitor is medially located in non-palinurans [this study; Wiens & Wolf 1993], but all the cells exiting N1AV in *J. novaehollandiae* are located in the anterior-lateral cell cluster. This implies that in *J. novaehollandiae*, SI is located in the anterior-lateral cluster, not medially as in the astacideans and anomurans examined to date.

The cells exiting via N1AV in *J. novaehollandiae* are the FEs, REs, OE≡SE, and SI [Silvey 1981]. With the exception of SI, the remaining seven neurons are in the same

location in astacideans and anomurans studied so far. In non-palinurans, NIPV contains CI, aFE, the CEs, EEs, BEs. If the positions of these cells were the same in palinurans, there would be five cells (CEs, EEs, and BE_α) in the anterior-lateral cell cluster filled via NIPV, not three. This implies that at least two of these five neurons are located posterior-lateral in palinurans but anterior-lateral in non-palinurans. This is consistent with *J. novaehollandiae* having four posterior-lateral neurons, rather than the three in non-palinurans (one of which is OI, which palinurans seem to lack).

Thus, the evidence points to at least four differences between palinurans and non-palinurans in their leg motor neuron complement: the absence of OI, and different locations of SI and two unidentified excitors. Because soma location changes very little during neural ontogeny [Bastiani et al. 1984], SI and the two excitors are more likely to have been deleted and replaced during speciation than to have moved within the ganglion, implying that these three motor neurons are *not* homologous in palinurans and non-palinurans. Considering the putative homology of the inhibitory neurons between crayfish and locusts [Wiens & Wolf 1993], this would be a significant change from the decapod leg motor neuron ground plan. If the differences in somata location are confirmed by physiological identification, I suggest that these palinuran motor neurons be identified as analogues of the functionally equivalent cells in non-palinurans. For example, the inhibitory neuron to the palinuran stretcher muscle could be termed the stretcher inhibitor analogue (SI_A). This nomenclature would reflect the order in which these neurons were described, and not imply that the non-palinuran cell is the ancestral one. Such a scheme is similar to one used by Sillar and Heitler [1985] and would be consistent with Rowell's recommendations [1989] for identified neuron nomenclature.

Palinurans are frequently used as models for the neuroethological study of walking in crustaceans [Ayers & Clarac 1978; Chasserat & Clarac 1983; Clarac & Chasserat 1983; Clarac 1984; Müller & Clarac 1990a, 1990b], and the assumption has been that palinurans are so similar to other decapods, especially astacideans, that any differences will be minor. This may be true of the interleg coordination: there is no evidence so far of any differences in palinuran neuromusculature for the proximal muscles [Clarac 1984] or in sensory input

[Müller & Clarac 1990a, 1990b], both of which are important factors in interleg coordination [Cruse 1990; Sillar et al. 1987]. Reflexes within single limbs and interjoint coordination, however, may not be as well conserved as the interlimb coordination seems to be, because of the apparent replacement of some motor neurons. Reflexes and interjoint coordination have received less attention than interleg coordination, and researchers should be cautious when comparing these features in palinurans [e.g., Ayers & Clarac 1978; Müller & Clarac 1990a] and non-palinurans [e.g., Barnes 1977; El Manira et al. 1991a, 1991b].

The disparity of leg motor neuron organisation in *J. novaehollandiae* [Silvey 1981] compared with leg motor neurons in other species is provocative in light of a suggestion that palinurans are not decapods or even eucarids, because of the “enormous” differences between palinuran larvae and those of other decapods [Williamson 1988]. The stomatogastric nervous system of palinurans is also unusual compared to that of other reptantians [Katz & Tazaki 1992]. My data on leg motor neurons would support an hypothesis of early divergence of *Palinura* from the rest of the reptantians (or, perhaps, that Reptantia are polyphyletic). My speculations are limited by the facts that the distal leg innervation has not been completely worked out in any non-reptantian decapods (i.e., shrimp and prawns), either peripherally [Wiersma & Ripley 1952] or centrally, and that there is no generally accepted phylogeny proposed for Reptantia [Schram 1986]. The differences in leg motor neuron anatomy between species with similar behaviours (palinurans and many other reptantians) is contrasted against the fact that I found no significant differences in the central morphology or number of neurons of species with divergent behaviours: walking in crayfish and squat lobsters and digging in sand crabs. This finding joins a growing list of examples of how neural anatomy can be conserved in evolution despite large changes in behaviour [Katz & Tazaki 1992; Kavanau 1990; Paul 1991].

Chapter 7: Synthesis

It is more important that a proposition be interesting than that it be true.
[Whitehead 1933: 243]

Hypotheses of homology

Two evolutionary questions have been considered throughout this work. First, is digging homologous within the sand crab superfamily, and, if so, how conserved is it? Second, what are the evolutionary origins of digging?

Homology and divergence within the sand crabs

The evidence strongly favours a monophyletic origin for digging in the sand crab superfamily, which then diverged in the two sand crab families. An advantage of an expressly phylogenetic study of a behaviour is that it provides the ability to predict the behaviour patterns of related species. Throughout most of this project, however, it was an open question whether the differences in digging patterns seen between *B. occidentalis* and *E. analoga* (e.g., the gait switch) were species, genus, or familial differences, or whether the differences might be better explained by non-phylogenetic differences, particularly size. This question was answered relatively late in this project, when I was able to study *L. californica* (Albuneidae), and found that its digging patterns are much more similar to *B. occidentalis* than to *E. analoga*. This effectively ruled out size as a source of the species differences, and suggests that the other albuneid species will be found to have the same digging patterns, because the genera *Blepharipoda* and *Lepidopa* are not closely related (Figure 1.1B). Likewise, I suspect that the other hippid genera will have digging patterns similar to *E. analoga*.

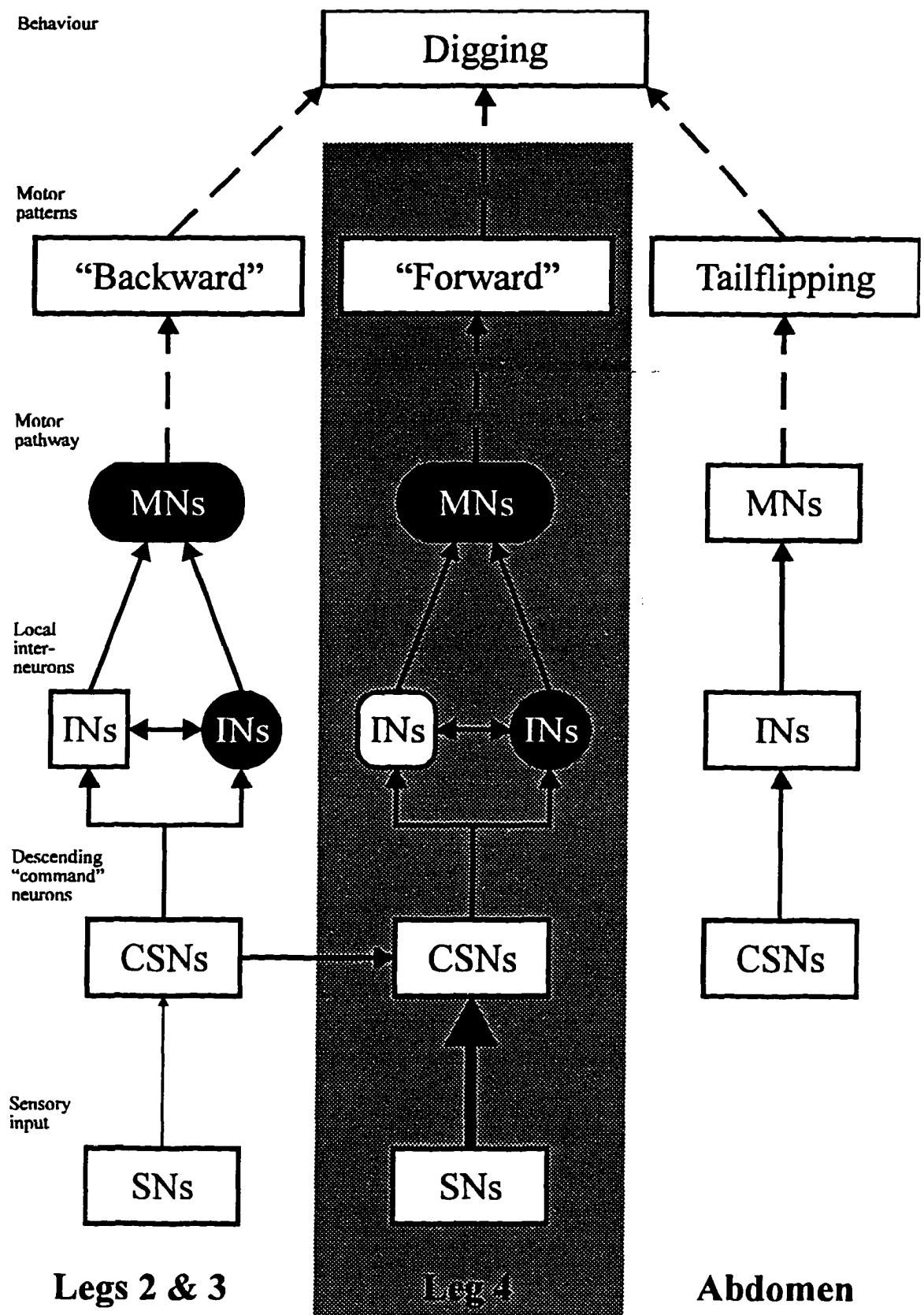
Homology of digging and walking

The relationship of digging to behaviours in other crustaceans is more difficult to assess than the changes that have occurred since digging originated within the sand crab superfamily. I proposed several hypotheses concerning the origin of the digging. My

original hypothesis was that digging is a modified form of backward walking. The differences in the motor output of serially homologous legs, however, suggested the “mosaic hypothesis” (Figure 7.1): digging is comprised of a modified form of backward walking in legs 2 and 3, and forward walking in leg 4. More generally stated, the mosaic hypothesis suggests that a “new” behaviour originated by combining disparate motor outputs of multiple pattern generators, which previously were not used simultaneously. This mosaic hypothesis could be applied to behaviours besides sand crab digging.

Figure 7.1: Model of neural bases for sand crab digging

Hypothesised model of the neural bases of sand crab digging. One command system is predicted to initiate rhythmic activity of both legs 2 and 3. This hypothesised command system may influence a second, separate command system initiating rhythmic activity of leg 4; this is suggested by the ability of legs 2 and 3 to cycle without leg 4, and the inability of leg 4 to cycle alone. An hypothesised third command system initiates abdominal movements. The movements of the legs all involve serially homologous motor neurons, but only some serially homologous interneurons. The relative importance of sensory input in initiating leg movements is indicated by the thickness of the arrows from the sensory neuron pool. Coordinating pathways (e.g., those that cause leg 4 to have the same frequency as 2 and 3 in the albuneids, or for leg 4 to cycle at the same frequency as the uropods in *E. analoga*) are not shown. Solid arrows = hypothesised neural connections of unspecified sign; dashed arrows = functional links between behavioural elements; black symbols = serially homologous pools of neurons; MNs = motor neurons; CSNs = command system neurons; INs = interneurons; SNs = sensory neurons.



In the case of sand crab digging, the disparate motor output of the pattern generators (i.e., leg 2 and 3 compared with leg 4) may have resulted from the specialisation of pattern generators in the sand crab ancestor that were multifunctional, but were homogeneous in serially homologous thoracic hemiganglia. The ability of the neural circuitry in a thoracic hemiganglion to generate several different motor patterns for a walking leg may be an important preadaptation for specialisation because it is a redundancy in motor function. Such redundancy in function may be analogous to a structural duplication, which can be an impetus for evolutionary innovation in two ways [see Lauder 1990; Lauder & Liem 1989 for discussion]. It increases the number of potentially functional ways that structures be connected, and can provide a "back-up system," enabling one duplicate to specialise while the other retains the original function. For example, losing the ability to walk forwards rapidly could be highly deleterious to an organism, if walking forward were the only type of locomotion it was capable of; such a loss, however, would be less disadvantageous if the animal retains the ability to walk backwards and sideways.

Testing the mosaic hypothesis depends on getting further information about the pattern generators for walking and digging. Additionally, as more features about the neuronal control of walking and digging are uncovered, it will be increasingly important to have a framework for testing the hypothesis quantitatively. Hypotheses about the evolutionary relationships between organisms are routinely tested using quantitative cladistic methods [Brooks & McLennan 1991; Nelson & Platnick 1981]. Logically, the relationships between parts of organisms (i.e., characters) are no different in principle than the relationships between the organisms themselves. For example, bird *wings* are a monophyletic group of *organs*, just as birds are a monophyletic group of organisms [Nelson 1994]. So hypotheses about evolutionary relationships between the parts of organisms (such as homology) could be evaluated using the same methodology. Simplistically, constructing or testing an organismal phylogeny is based on the premise that the taxa sharing the most characters are the most closely related. Any organism is a constellation of a very large number of characters, but any definable character has a

restricted set of *other characters* associated with it (for this discussion, I will term these “characteristics”). To continue with the example above, a “wing” might be a single character used in constructing an organismal phylogeny. A wing, in turn, has *characteristics* like feathers, bones, muscles, regulatory genes, and functions (all of these wing characteristics are, of course, characters of whole organisms too). These characteristics could then be analysed as whole organism characters are. Matrices of characteristics would be set up (e.g., Table 7.1), and analysed with algorithms to sort those characters that have the most common characteristics, resulting in diagrammatic “trees” which show possible relationships between characters. Outgroups would be used, as in organismal analyses; a crocodylian forelimb may be appropriate in this case. What complicates this sort of analysis are the complex relationships between characters and characteristics, which are necessarily at different levels of analysis [Streider & Northcutt 1991]. Another complication is that organisms cannot literally share a particular physical instantiation of a character: two birds may both have wings, for instance, but they cannot both have the *same* wing. Conversely, characters can literally share the exact same physical instantiation of a characteristic: for example, two behaviours (i.e., different organismal characters) may easily share at least some neurons [Gallistel 1980; Dickinson & Moulins 1992] (i.e., the exact same characteristics). Despite these as yet unresolved complications, this variation of cladistic analysis might be useful in quantitatively evaluating the homologies suggested by the mosaic hypothesis.

Table 7.1: Sample matrix of locomotor characteristics

A matrix of characteristics for locomotor characters in decapods. In this simplistic example, digging by legs 2 and 3 shares three characteristics with digging by leg 4 and astacidean backward walking.

Behaviour	Elevation followed by remotion?	Opener inhibitor (OI) neuron?	Bilateral synchrony?	Movements by all distal leg joints?	Levator and extensor synergists?
Astacidean forward walking	0	1	0	0	0
Astacidean backward walking	1	1	0	0	1
Palinuran forward walking	0	0?	0	0	0
Palinuran backward walking	1	0?	0	0	1
Sand crab digging (leg 2 & 3)	1	1	1	1	1
Sand crab digging (leg 4)	0	1	1	1	0

What next?

There are several lines of investigation that could be followed from this work. First, a study on the sensory organs and afferent innervation of sand crab legs would be useful. Several observations suggest that sensory input, particularly those that sense load on the legs, trigger a suite of related changes in interleg coordination, coordination of the legs and “tail,” and EMG burst size. The sense organs of the thoracic-coxal joint are particularly likely to be important to regulating the behaviour (Chapter 2, Sensory input: 70).

Secondly, there are several hypotheses about the distal leg motor neurons that can be tested (Chapter 6, Distal leg motor neurons: 187). These include: positively identifying (via physiological experiments) the central locations of neurons like the bender excitors and the accessory flexor excitor; testing the hypothesised functional connections between neurons (e.g., between BE_p and OI), and confirming the anatomical differences between palinurans and non-palinurans. Of course, these findings would also have relevance to other studies on crustacean movement and behaviour.

Third, many of the hypotheses concerning the evolution and neural control of sand crab digging could only be tested rigorously if an *in vitro* “fictive digging” preparation is developed. For example, the effect of sensory input and reflexes on reorganising the behaviour can only be assessed in an active preparation, because it is known that many reflexes have different effects depending on whether stimuli are applied when the nervous system is in an active or quiescent state [e.g., El Manira et al. 1991; Head & Bush 1991; Sillar et al. 1986; Skorupski & Bush 1992; Skorupski & Sillar 1986]. Likewise, an *in vitro* preparation would allow a search for interneurons that are involved in the regulation of the digging motor pattern. The hypothesised homologies between digging and walking predict that some of these interneurons in sand crabs will have features similar to those that are starting to be found in crayfish [Pearlstein & Clarac 1995]. Examining fictive digging *in vitro* would be a prerequisite for examining possible mechanisms of interjoint coordination.

Fourth, the brachyuran superfamily Raninoidea de Haan, 1841 are true crabs that, like hippoid sand crabs, are specialised for digging in sand and mud. Their gross morphology is reminiscent of albuneids: unlike the thorax of most brachyurans, the thorax of ranid crabs is not rostro-caudally compressed, and their legs have very flat, paddle-shaped dactyls. Comparing the convergent digging behaviours in the ranid crabs with the hippoid sand crabs could be illuminating in understanding the biomechanics of digging.

REFERENCES

- Alexander, R.McN. 1989. Optimization and gaits in the locomotion of vertebrates. *Physiological Reviews* 69(4): 1199-1227.
- Arbas, E.A., Meinertzhagen, I.A., & Shaw, S.R. 1991. Evolution in nervous systems. *Annual Review of Neuroscience* 14: 9-38.
- Arshavsky, Yu. I., Orlovsky, G.N., Panchin, Yu. V., Roberts, A., & Soffe, S.R. 1993. Neuronal control of swimming locomotion: analysis of the pteropod mollusc *Clione* and embryos of the amphibian *Xenopus*. *Trends in Neuroscience* 16(6): 227-233
- Asimov, I. 1988. *Prelude to Foundation*. New York: Doubleday.
- Atwood, H.L. 1976. Organization and synaptic physiology of crustacean neuromuscular systems. *Progress in Neurobiology* 7: 291-391.
- Atwood, H.L. 1977. Crustacean neuromuscular systems: past, present, and future. In: G. Hoyle (ed.), *Identified Neurons and Behavior of Arthropods*, pp. 9-29. New York: Plenum Press.
- Atwood, H.J. & Walcott, B. 1965. Recording of electrical activity and movement from legs of walking crabs. *Canadian Journal of Zoology* 43(5): 657-665.
- Atz, J.W. 1970. The application of the idea of homology to behavior. In: L.R. Aronson, E. Tobach, D.S. Lehrman & J.S. Rosenblatt (eds.), *Development and Evolution of Behavior: Essays in Memory of T.C. Schneirla*, pp. 53-74. San Francisco: W.H. Freeman & Co.
- Averof, M. & Akam, M. 1995. Insect-crustacean relationships: insights from comparative developmental and molecular studies. *Philosophical Transactions of the Royal Society, London B* 347: 293-303.
- Ayers, J. & Clarac, F. 1978. Neuromuscular strategies underlying different behavioral acts in a multifunctional crustacean leg joint. *Journal of Comparative Physiology A* 128: 81-94.
- Ayers, J.L. & Davis, W.J. 1977. Neuronal control of locomotion in the lobster, *Homarus americanus* I. Motor programs for forward and backward walking. *Journal of Comparative Physiology A* 115: 1-27.
- Ayers, J.L., Kashin, S., Blidberg, D.R., & Massa, D. 1994. Biologically-based underwater robots. *Unmanned Systems* 12: 30-36

- Bacon, J.P. & Altman, J.S. 1977. A silver intensification method for cobalt filled neurons in wholmount preparations. *Brain Research* 138: 359-363.
- Baker, J.R. 1958. *Principles of Biological Microtechnique*. London: Methuen & Co., Ltd.
- Barlow, G.W. 1968. Ethological units of behavior. In: D. Ingle (ed.), *The Central Nervous System and Fish Behavior*, pp. 217-232. Chicago: Chicago University Press.
- Barlow, G.W. 1977. Modal action patterns. In: T.A. Sebeok (ed.), *How Animals Communicate*, pp. 98-134. Bloomington: Indiana University Press.
- Barlow, G.W. 1989. Has sociobiology killed ethology or revitalized it? In: P.P.G. Bateson & P.H. Klopfer, (eds.), *Perspectives in Ethology, Volume 8: Whither Ethology?*, pp. 1-45. New York: Plenum Press.
- Barnes, W.J.P. 1977. Proprioceptive influences on motor output during walking in the crayfish. *Journal of Physiology, Paris* 73: 543-564.
- Barnes, W.J.P & Barth, F.G. 1991. Sensory control of locomotor mode in semi-aquatic spiders. In: D.M. Armstrong & B.M.H. Bush (eds.), *Locomotor Neural Mechanisms in Arthropods and Vertebrates*, pp. 105-106. Manchester: Manchester University Press.
- Bässler, U. 1993. The femur-tibia control system of stick insects — a model system for the study of the neural basis of joint control. *Brain Research Reviews* 18: 207-226.
- Bastiani, M., Pearson, K.G., & Goodman, C.S. 1984. From embryonic fascicles to adult tracts: organization of neuropile from a developmental perspective. *The Journal of Experimental Biology* 112: 45-64.
- Beltz, B.S. & Kravitz, E.A. 1987. Physiological identification, morphological analysis, and development of identified serotonin-proctolin containing neurons in the lobster ventral nerve cord. *The Journal of Neuroscience* 7(2): 533-546.
- Bernstein, N. 1984. The problem of the interrelation of co-ordination and localization. In: H.T.A. Whiting (ed.), *Human Motor Actions: Bernstein Reassessed*, pp. 77-119. New York: North-Holland.
- Beschin, C. & de Angeli, A. 1984. Nove forme fossili di Anomura Hippidea: *Albunea cuisiana* sp. n. e *Albunea lutetiana* sp. n. *Societa Veneziana di Scienze Naturali Lavori* 9(1): 93-105.

- Bévengut, M., Cattaert, D. & Clarac, F. 1995. Synaptic connections of the leg common inhibitor in crayfish. In: M. Burrows, T. Matheson, P.L. Newland & H. Schuppe (eds.), *Nervous Systems And Behaviour: Proceedings of the 4th International Congress of Neuroethology*, pp.463. Stuttgart: Georg Thieme Verlag.
- Bévengut, M., Simmers, A.J., & Clarac, F. 1983. Central neuronal projections and neuromuscular organization of the basal region of the shore crab leg. *Journal of Comparative Neurology* 221: 185-198.
- Bowerman, R.F. & Larimer, J.L. 1974. Command fibres in the circumoesophageal connectives of crayfish II. Phasic fibres. *The Journal of Experimental Biology* 60: 119-134.
- Bowman, T.E. & Abele, L.G. 1982. Classification of the Recent Crustacea. In: D.H. Bliss (ed.-in-chief), L.G. Abele (ed.), *The Biology of Crustacea, Volume 1: Systematics, the Fossil Record, and Biogeography*, pp. 1-27. New York: Academic Press.
- Brady, R.H. 1994. Pattern description, process explanation, and the history of morphological sciences. In: L. Grande & O. Reippel (eds.), *Interpreting the Hierarchy of Nature: From Systematic Patterns to Evolutionary Process Theories*, pp. 7-31. San Diego: Academic Press.
- Brooks, D.R. & McLennan, D.A. 1991. *Phylogeny, Ecology, and Behavior: A Research Program in Comparative Biology*. Chicago: Chicago University Press.
- Burrows, M. & Hoyle, G. 1973. The mechanism of rapid running in the ghost crab, *Ocypode ceratophthalma*. *The Journal of Experimental Biology* 58: 327-349.
- Burghardt, G.M. & Gittleman, J.L. 1990. Comparative behavior and phylogenetic analyses: new wine, old bottles. In: M. Bekoff & D. Jamieson (eds.), *Interpretation and Explanation in the Study of Animal Behavior, Volume II: Explanation, Evolution, and Adaptation*, pp. 192-225. Boulder: Westview Press.
- Büschges, A., Kittman, R. & Schmitz, J. 1994. Identified nonspiking interneurons in leg reflexes and during walking in the stick insect. *Journal of Comparative Physiology A* 174: 685-700.
- Büschges, A., Schmitz, J. & Bässler, U. 1995. Rhythmic patterns in the thoracic nerve cord of the stick insect induced by pilocarpine. *The Journal of Experimental Biology* 198: 435-456.
- Bush, B.M.H. 1962. Proprioceptive reflexes in the legs of *Carcinus maenas* (L.). *The Journal of Experimental Biology* 39: 89-105.

- Bush, B.M.H. 1965. Leg reflexes from chodotonal organs in the crab, *Carcinus maenas*. *Comparative Biochemistry and Physiology* 15: 567-587.
- Bush, B.M.H. 1981. Non-impulsive stretch receptors in crustaceans. In: A. Roberts & B.M.H. Bush (eds.), *Neurones Without Impulses: Their Significance for Vertebrate and Invertebrate Nervous Systems*, pp. 147-176. Cambridge: Cambridge University Press.
- Bush, B.M.H. & Laverack, M.S. 1982. Mechanoreception. In: D.H. Bliss (ed.-in-chief), H.L. Atwood & D.C. Sandeman (eds.), *The Biology of Crustacea, Volume 3: Neurobiology: Structure and Function*, pp. 399-468. New York: Academic Press.
- Cassutt, M. 1987. "Deities," episode 8 of *Max Headroom* television series. Directed by Tom Wright. First broadcast on 25 September 1987. Lorimar-Telepictures.
- Cattaert, D., Bévengut, M. & Clarac, F. 1993. Synaptic connections between sensory afferents and the common inhibitory motoneuron in crayfish. *Journal of Comparative Physiology A* 172: 71-79.
- Cazalets, J.-R. 1995. Dual control of central pattern generators: neonatal rat spinal cord *in vitro*. In: W.R. Ferrell & U. Proske (eds.), *Neural Control of Movement*, pp. 187-194. New York: Plenum Press.
- Cazalets, J.-R., Borde, M., & Clarac, F. 1995. Localization and organization of the central pattern generator for hindlimb locomotion in newborn rat. *The Journal of Neuroscience* 15(7): 4943-4951.
- Chasserat, C. & Clarac, F. 1983. Quantitative analysis of walking in a decapod crustacean, the rock lobster *Jasus lalandii*. II. Spatial and temporal regulation of stepping in driven walking. *The Journal of Experimental Biology* 107: 219-243.
- Chrachri, A. & Clarac, F. 1987. Induction of rhythmic activity in motoneurons of crayfish thoracic ganglia by cholinergic agonists. *Neuroscience Letters* 77: 49-54.
- Chrachri, A. & Clarac, F. 1989. Synaptic connections between motor neurons and interneurons in the fourth thoracic ganglion of the crayfish, *Procambarus clarkii*. *Journal of Neurophysiology* 62(6): 1237-1250.
- Chrachri, A. & Clarac, F. 1990. Fictive locomotion in the fourth thoracic ganglion of the crayfish, *Procambarus clarkii*. *Journal of Neuroscience* 10(3): 707-719.
- Clarac, F. 1977. Motor coordination in crustacean limbs. In: G. Hoyle (ed.), *Identified Neurons and Behavior of Arthropods*, pp. 167-186. New York: Plenum Press.

- Clarac, F. 1984. Spatial and temporal co-ordination during walking in Crustacea. *Trends in Neuroscience* 7(8): 293-298.
- Clarac, F. & Barnes, W.J.P. 1985. Peripheral influences on the coordination of the legs during walking in decapod crustaceans. In: B.M.H. Bush & F. Clarac (eds.), *Coordination of Motor Behaviour*, pp. 249-269. Cambridge: Cambridge University Press.
- Clarac, F. & Chasserat, C. 1983. Quantitative analysis of walking in a decapod crustacean, the rock lobster *Jasus lalandii*. I. Comparative study of free and driven walking. *The Journal of Experimental Biology* 107: 189-217.
- Clarac, F., Libersat, F., Pflüger, H.J. & Rathmayer, W. 1987. Motor pattern analysis in the shore crab (*Carcinus maenas*) walking freely in water and on land. *The Journal of Experimental Biology* 133: 395-414.
- Clayton, D.H. & Harvey, P.H. 1993. Hanging nests on a phylogenetic tree. *Current Biology* 3(12): 882-883.
- Cocroft, R.B. & Ryan, M.J. 1995. Patterns of advertisement call evolution in toads and chorus frogs. *Animal Behaviour* 49(2): 283-303.
- Cooke, I.R.C. & Macmillan, D.L. 1983. The common inhibitory innervation of the pereopods of the crayfish *Cherax destructor*. *The Journal of Experimental Zoology* 225: 513-517.
- Cooke, I.R.C. & MacMillan, D.L. 1985. Further studies of crayfish escape behaviour. I. The role of the appendages and the stereotyped nature of non-giant escape swimming. *The Journal of Experimental Biology* 118: 351-365.
- Cruse, H. 1990. What mechanisms coordinate leg movement in walking arthropods? *Trends in Neuroscience* 13(1): 15-21.
- Cubit, J. 1969. Behavior and physical factors causing migration and aggregation of the sand crab *Emerita analoga* (Stimpson). *Ecology* 50(1): 118-123.
- Davis, W.J. 1969. The neural control of swimmeret beating in the lobster. *The Journal of Experimental Biology* 50: 99-117.
- Davis, W.J. 1971. Functional significance of motor neuron size and soma position in swimmeret system of the lobster. *Journal of Neurophysiology* 34: 274-288.

- Davis, W.J. 1973. Neuronal organization and ontogeny in the lobster swimmeret system. In: R.B. Stein, K.G. Pearson, R.S. Smith & J.B. Redford, *Control of Posture and Locomotion (Advances in Behavioural Biology, Volume 7)*, pp. 437-455. New York: Plenum Press.
- Dawkins, M.S. 1983. The organisation of motor patterns. In: T.R. Halliday & P.J.B. Slater (eds.), *Animal Behaviour • Volume 1: Causes and Effects*, pp. 75-99. Oxford: Blackwell Scientific Publications.
- Dawkins, M.S. 1989. The future of ethology: how many legs are we standing on? In: P.P.G. Bateson & P.H. Klopfer (eds.), *Perspectives in Ethology, Volume 8: Whither Ethology?*, pp. 47-54. New York: Plenum Press.
- de Queiroz, A. & Wimberger, P.H. 1993. The usefulness of behavior for phylogeny estimation: levels of homoplasy in behavioral and morphological characters. *Evolution* 47(1): 46-60.
- Dean, J. 1992. Is equilibrium-point control all there is to coding movement and do insects do it, too? *Behavioural and Brain Sciences* 15(4): 731-732.
- Dickinson, P.S. & Moulins, M. 1992. Interactions and combination between different networks in the stomatogastric nervous system. In: R.M. Harris-Warrick, E. Marder, A.I. Selverston & M. Moulins (eds.), *Dynamic Biological Networks: The Stomatogastric Nervous System*, pp. 139-160. Cambridge: MIT Press.
- Drummond, H. 1981. The nature and description of behavior patterns. In: P.P.G. Bateson & P.H. Klopfer (eds.), *Perspectives in Ethology, Volume 4: Advantages of Diversity*, pp. 1-33. New York: Plenum Press.
- Dudel, J. & Kuffler, S.W. 1961. Presynaptic inhibition at the crayfish neuromuscular junction. *Journal of Physiology (London)* 155: 543-562.
- Dugan, J.E., Hubard, D.M. & Wenner, A.M. 1994. Geographic variation in life history of the sand crab, *Emerita analoga* (Stimpson) on the California coast: relationships to environmental variables. *Journal of Experimental Marine Biology and Ecology* 181: 255-278.
- Efford, I.E. 1969. *Leucolepidopa sunda* gen. nov., sp. nov. (Decapoda: Albuneidae), a new Indo-Pacific sand crab. *Breviora* 318: 1-9.
- Efford, I.E. 1971. The species of sand crabs in the Genus *Lepidopa* (Decapoda: Albuneidae). *Zoologischer Anzeiger* 186(1): 59-102.

- Eilam, D. 1994. Influence of body morphology on turning behavior in carnivores. *Journal of Motor Behavior* 26(1): 3-12.
- El Manira, A., Cattaert, D., & Clarac, F. 1991a. Monosynaptic connections mediate resistance reflex in crayfish (*Procambarus clarkii*) legs. *Journal of Comparative Physiology A* 168: 337-349.
- El Manira, A., DiCaprio, R.A., Cattaert, D., & Clarac, F. 1991b. Monosynaptic interjoint reflexes and their central modulation during fictive locomotion in crayfish. *European Journal of Neuroscience* 3: 1219-1231.
- Elson, R.C. 1995. Neuroanatomy of a crayfish thoracic ganglion: sensory and motor root of the walking-leg nerves and possible homologies with insects. *The Journal of Comparative Neurology*: in press.
- Eshkol, N. & Wachman, A. 1958. *Movement Notation*. London: Weidenfield & Nicholson.
- Eshkol, N. 1980. *50 Lessons By Dr. Moshe Feldenkrais*. Tel-Aviv: The Movement Notation Society.
- Evoy, W.H. & Ayers, J. 1982. Locomotion and control of limb movements. In: D.H. Bliss (ed.-in-chief), D.C. Sandeman & H.L. Atwood (eds), *The Biology of Crustacea, Volume 4: Neural Integration and Behavior*, pp. 61-105. New York: Academic Press.
- Evoy, W.H. & Fournier, C.R. 1973. Crustacean walking. In: R.B. Stein, K.G. Pearson, R.S. Smith & J.B. Redford (eds.), *Control of Posture and Locomotion (Advances in Behavioural Biology, Volume 7)*, pp. 477-493. New York: Plenum Press.
- Faulkes, Z. & Paul, D.H. 1992. Connecting invertebrate behavior, physiology and evolution with Eshkol-Wachman movement notation. *Behavioral and Brain Sciences*, 15(2): 276-277.
- Faulkes, Z. & Paul, D.H. 1993. Interjoint coordination and muscle activity in legs of digging sand crabs. *Society for Neuroscience Abstracts* 19(2): 1600.
- Faulkes, Z. & Paul, D.H. 1995. Sand crab digging: an evolutionary mosaic of disparate ancestral locomotor modules? In: M. Burrows, T. Matheson, P.L. Newland, H. Schuppe (eds.), *Nervous Systems and Behaviour. Proceedings of the Fourth International Congress of Neuroethology*, pp. 483. Stuttgart: Georg Thieme Verlag.

- Faulkes, Z., Paul, D.H. & Pellis, S.M. 1991. Digging by the sand crab *Blepharipoda occidentalis*. *Society for Neuroscience Abstracts* 17(2): 1245.
- Fentress, J.C. 1990. The categorization of behavior. In: M. Bekoff & D. Jamieson (eds.), *Interpretation and Explanation in the Study of Animal Behavior, Volume I: Interpretation, Intentionality, and Communication*, pp. 7-34. Boulder: Westview Press.
- Fentress, J.C. 1992. Emergence of pattern in the development of mammalian movement sequences. *Journal of Neurobiology* 23(10): 1529-1556.
- Gallistel, C.R. 1980. *The Organization of Action: A New Synthesis*. Hillsdale: Lawrence Erlbaum Associates.
- Ganor, I. & Golani, I. 1980. Coordination and integration in the hindleg step cycle of the rat: kinematic synergies. *Brain Research* 195: 57-67.
- Gittleman, J.L. & Decker, D.M. 1994. The phylogeny of behaviour. In: P.J.B. Slater & T.R. Halliday (eds.), *Behaviour and Evolution*, pp. 80-105. Cambridge: Cambridge University Press.
- Glaessner, M.F. 1969. Decapoda. In: R.C. Moore (ed.), *Treatise on Invertebrate Paleontology, Part R: Arthropoda 4, Volume 2*, pp. R400-R533. Lawrence: University of Kansas & Boulder: The Geological Society of America, Inc.
- Golani, I. 1976. Homeostatic motor processes in mammalian interactions: a choreography of display. In: P.P.G. Bateson & P.H. Klopfer (eds.), *Perspectives in Ethology, Volume 2*, pp. 69-134. New York: Plenum Press.
- Golani, I. 1992. A mobility gradient in the organization of vertebrate movement: The perception of movement through symbolic language. *Behavioral and Brain Sciences* 15(2): 249-308.
- Golani, I. 1994. Continuing commentary on "A mobility gradient in the organization of vertebrate movement: The perception of movement through symbolic language." *Behavioral and Brain Sciences* 17(4): 752-757.
- Golani, I., Bronchti, G., Moualem, D. & Teitelbaum, P. 1981. "Warm-up" along dimensions of movement in the ontogeny of exploration in rats and other infant mammals. *Proceedings of the National Academy of Science USA* 78(11): 7226-7229.
- Govind, C.K. & Lang, F. 1981. Physiological identification and asymmetry of lobster claw closer motoneurons. *The Journal of Experimental Biology* 94: 329-339.

- Govind, C.K. & Wiens, T.J. 1985. Innervation of the limb accessory flexor muscle in several decapod crustaceans. I. Anatomy. *Journal of Neurobiology* 16: 317-328.
- Grande, L. & Reippel, O. (eds.). 1994. *Interpreting the Hierarchy of Nature: From Systematic Patterns to Evolutionary Process Theories*. San Diego: Academic Press.
- Greene, H.W. 1994. Homology and behavioral repertoires. In: B.K. Hall (ed.), *Homology: The Hierarchical Basis of Comparative Biology*, pp. 369-391. San Diego: Academic Press.
- Grillner, S. 1985. Neurobiological bases of rhythmic motor acts in vertebrates. *Science* 228: 143-149.
- Grillner, S., Deliagina, T., Ekeberg, Ö., El Manira, A., Hill, R.H., Lansner, A., Orlovsky, G.N., & Wallén, P. 1995. Neural networks that co-ordinate locomotion and body orientation in lamprey. *Trends in Neurosciences* 18(6): 270-279.
- Haig, J. 1974. A review of the Australian crabs of family Hippidae (Crustacea, Decapoda, Anomura). *Memoirs of the Queensland Museum* 17(1): 175-189.
- Haig, J. & Abbott, D.P. 1980. Macrura and Anomura: The ghost shrimps, hermit crabs, and allies. In: R.H. Morris, D.P. Abbott & E.C. Haderlie (eds.), *Intertidal Invertebrates of California*, pp. 577-593. Stanford: Stanford University Press.
- Hall, B.K. (ed.). 1994. *Homology: The Hierarchical Basis of Comparative Biology*. San Diego: Academic Press.
- Harris-Warrick, R.M., Marder, E., Selverston, A.I. & Moulins, M. (eds.). 1992. *Dynamic Biological Networks: The Stomatogastric Nervous System*. Cambridge: MIT Press.
- Hartnoll, R.G. 1970. Swimming in the dromiid crab (*Homola barbata*). *Animal Behaviour* 18: 588-591.
- Harvey, P.H. & Pagel, M.D. 1991. *The Comparative Method in Evolutionary Biology*. Oxford: Oxford University Press.
- Head, S.I. & Bush, B.M.H. 1991. Proprioceptive reflex interactions with central motor rhythms in the isolated thoracic ganglion of the shore crab. *Journal of Comparative Physiology A* 168: 445-459.
- Head, S.I. & Bush, B.M.H. 1992. Proprioceptive input from two basal joint stretch receptors to leg motoneurons in the isolated thoracic ganglion of the shore crab. *The Journal of Experimental Biology* 163: 187-208.

- Hebb, D.O. 1949. *The Organization of Behavior: A Neuropsychological Theory*. New York: Wiley.
- Heitler, W.J. 1978. Coupled motoneurons are part of the crayfish swimmeret central oscillator. *Nature* 275: 231-234.
- Heitler, W.J. & Darrig, S. 1986. The segmental giant neurone of the signal crayfish, *Pacifastacus leniusculus*, and its interactions with abdominal fast flexor and swimmeret motor neurons. *The Journal of Experimental Biology* 121: 55-75.
- Heitler, W.J. & Fraser, K. 1989. Thoracic output of crayfish giant fibres. I. Pereiopod promotor motor neurones. *Journal of Comparative Physiology A* 166: 117-124.
- Herreid, C.F. & Full, R.J. 1986. Locomotion of hermit crabs (*Coenobita compressus*) on beach and treadmill. *The Journal of Experimental Biology* 120: 283-296.
- Hessler, R.R. 1982. The structural morphology of walking mechanisms in eumalacostracan crustaceans. *Philosophical Transactions of the Royal Society of London B* 296: 245-298.
- Hessler, R.R. 1985. Evolution of arthropod locomotion: a crustacean model. In: W.J.P. Barnes & M.H. Gladden (eds.), *Feedback and Motor Control in Invertebrates and Vertebrates*, pp. 9-30. London: Croom Helm.
- Hill, G.W. 1979. Biogenic sedimentary structures produced by the mole crab *Lepidopa websteri* Benedict. *The Texas Journal of Science* 31(1): 43-51.
- Hillis, D.M. 1994. Homology in molecular biology. In: B.K. Hall (ed.), *Homology: The Hierarchical Basis of Comparative Biology*, pp. 339-368. San Diego: Academic Press.
- Hubbard, A.W. 1960. Homokinetics: muscular function in human movement. In: W.R. Johnson (ed.), *Science and Medicine of Exercise and Sports*, pp. 7-39. New York: Harper & Row.
- Huddart, H. & Bradbury, S.J. 1972. Fine structure of a neurosecretory axon in a crustacean muscle. *Experientia* 28: 950-951.
- Hutchinson Guest, A. 1984. *Dance Notation: The Process of Recording Movement on Paper*. London: Dance Books.
- Hutchinson Guest, A. 1989. *Choreo-Graphics: A Comparison of Dance Notation Systems from the Fifteenth Century to the Present*. New York: Gordon and Breach.
- Huxley, T.H. 1880. *The Crayfish: An Introduction to the Study of Zoology*. London: C. Kegan Paul & Co.

- Jacobs, W.J., Blackburn, J.R., Buttrick, M., Harpur, T.J., Kennedy, D., Mana, M.J., MacDonald, M.A., McPherson, L.M., Paul, D. & Pfaus, J.G. 1988. Observations. *Psychobiology* 16(1): 3-19.
- Jamon, M. & Clarac, F. 1995. Locomotor patterns in freely moving crayfish (*Procambarus clarkii*). *The Journal of Experimental Biology* 198(3): 683-700.
- Johnson, M.W. & Lewis, W.M. 1942. Pelagic larval stages of the sand crabs *Emerita analoga* (Stimpson), *Blepharipoda occidentalis* Randall, and *Lepidopa myops* Stimpson. *Biological Bulletin* 83(1): 67-87.
- Johnston, R.M. & Levine, R.B. 1995. Crawling motor patterns in the isolated larval nerve cord of *Manduca sexta* induced by pilocarpine. In: M. Burrows, T. Matheson, P.L. Newland & H. Schuppe (eds.), *Nervous Systems And Behaviour: Proceedings of the 4th International Congress of Neuroethology*, pp.470. Stuttgart: Georg Thieme Verlag.
- Katz, P.S. & Tazaki, K. 1992. Comparative and evolutionary aspects of the crustacean stomatogastric system. In: R.M. Harris-Warrick, E. Marder, A.I. Selverston and M. Moulins (eds.), *Dynamic Biological Networks: The Stomatogastric Nervous System*, pp. 221-261. Cambridge: MIT Press.
- Kavanau, J.L. 1990. Conservative behavioural evolution, the neural substrate. *Animal Behaviour* 39: 758-767.
- Kelly, T.M. & Chapple, W.D. 1990. Kinematic analysis of the defense response in crayfish. *Journal of Neurophysiology* 64(1): 64-76.
- Kelso, J.A.S. 1984. Phase transitions and critical behavior in human bimanual coordination. *American Journal of Physiology* 246 (Regulatory, Integrative and Comparative Physiology 15): R1000-R1004.
- Kelso, J.A.S. & Scholz, J.P. 1985. Cooperative phenomena in biological motion. In: H. Haken (ed.), *Complex Systems — Operational Approaches in Neurobiology, Physics, and Computers*, pp 124-149. Berlin: Springer-Verlag.
- Kläerner, D. & Barnes, W.J.P. 1986. The cuticular stress detector (CSD2) of the crayfish. II. Activity during walking and influences on leg coordination. *The Journal of Experimental Biology* 122: 161-175.
- Knight, M.D. 1967. The larval development of the sand crab *Emerita rathbunae* Schmitt (Decapoda, Hippidae). *Pacific Science* 21: 58-76.

- Knight, M.D. 1968. The larval development of *Blepharipoda occidentalis* Randall and *B. spinimana* (Philippi) (Decapoda, Albuneidae). *Proceedings of the California Academy of Sciences*, Fourth Series 35(16): 337-370.
- Knox, C. & Boolootian, R.A. 1963. Functional morphology of the external appendages of *Emerita analoga*. *Bulletin of the Southern California Academy of Sciences* 62(2): 45-68.
- Kovac, M. 1974. Abdominal movements during backward walking in crayfish. *Journal of Comparative Physiology* 95: 61-78.
- Kroodsma, D.E. & Byers, B.E. 1991. The function(s) of bird song. *American Zoologist* 31: 318-328.
- Lafferty, K.D. 1993. Ecology and parasites of the spiny sand crab, *Blepharipoda occidentalis*. *American Zoologist* 33(5): 80A.
- Langtimm, C.A. & Dewsbury, D.A. 1991. Phylogeny and evolution of rodent copulatory behaviour. *Animal Behaviour* 41(2): 217-225.
- Larimer, J.L. 1976. Command interneurons and locomotor behavior in crustaceans. In: R.M. Herman, S. Grillner, P.S.G. Stein, & D.G. Stuart (eds.), *Neural Control of Locomotion*, pp.293-326. New York: Plenum Press.
- Larimer, J.L. 1988. The command hypothesis: a new view using an old example. *Trends in Neuroscience* 11: 506-510.
- Lauder, G.V. 1986. Homology, analogy, and the evolution of behavior. In: M.H. Nitecki & J.A. Mitchell (eds.), *Evolution of Animal Behavior*, pp. 9-40. New York: Oxford University Press.
- Lauder, G.V. 1990. Functional morphology and systematics: studying functional patterns in a historical context. *Annual Review of Ecology and Systematics* 21: 317-340.
- Lauder, G.V. 1991. Biomechanics and evolution: integrating physical and historical biology in the study of complex systems. In: J.M.V. Rayner & R.J. Wootton (eds.), *BioMechanics and Evolution*, pp. 1-18. Cambridge: Cambridge University Press.
- Lauder, G.V. 1994. Homology, form, and function. In: B.K. Hall (ed.), *Homology: The Hierarchical Basis of Comparative Biology*, pp. 151-196. San Diego: Academic Press.

- Lauder, G.V. & Liem, K.F. 1989. The role of historical factors in the evolution of complex organismal functions. In: D.H. Wake & G. Roth (eds.), *Complex Organismal Functions: Integration and Evolution in Vertebrates*, pg. 63-78. New York: John Wiley & Sons Ltd.
- Lochhead, J.H. 1961. Locomotion. In: T.H. Waterman (ed.), *The Physiology of Crustacea, Volume II: Sense Organs, Integration, and Behavior*, pp. 313-364. New York: Academic Press.
- Lorenz, K. 1970a. *Studies in Animal and Human Behaviour, Volume I*. (Translated by R. Martin.) London: Methuen & Co.
- Lorenz, K. 1970b. *Studies in Animal and Human Behaviour, Volume II*. (Translated by R. Martin.) London: Methuen & Co.
- Lorenz, K. 1981. *The Foundations of Ethology*. New York: Springer-Verlag.
- Macgintie, G.E. 1938. Movements and mating habits of the sand crab, *Emerita analoga*. *The American Midland Naturalist* 19(2): 471-481.
- Macmillan, D.L. 1975. A physiological analysis of walking in the American lobster (*Homarus americanus*). *Philosophical Transactions of the Royal Society of London* 270: 1-59.
- Marchand, A.R., Leibrock, C.S., Auriac, M.-C., Barnes, W.J.P. & Clarac, F. 1995. Morphology, physiology and in vivo activity of cuticular stress detector afferents in crayfish. *Journal of Comparative Physiology A* 176: 409-424.
- Martin, R. 1970. Translator's forward. In: K. Lorenz, *Studies in Animal and Human Behaviour, Volume I*. (Translated by R. Martin.) London: Methuen & Co.
- Mather, J.A. 1986. Sand digging in *Sepia officinalis*: assessment of a cephalopod mollusc's "fixed" behaviour pattern. *Journal of Comparative Psychology* 100(3): 315-320.
- McLaughlin, P.A. & Holthuis, L.B. 1985. Anomura versus Anomala. *Crustaceana* 49(2): 204-209.
- Moffett, S., Yox, D.P., Kahan, L.B., & Ridgway, R.L. 1987. Innervation of the anterior and posterior levator muscles of the fifth leg of the crab *Carcinus maenas*. *The Journal of Experimental Biology* 127: 229-248.
- Müller, U. & Clarac, F. 1990a. Dactyl sensory influences on rock lobster locomotion. I. Intrasegmental and intersegmental leg reflexes during standing and walking. *The Journal of Experimental Biology* 148: 89-112.

- Müller, U. & Clarac, F. 1990b. Dactyl sensory influences on rock lobster locomotion. II. Role in interleg coordination. *The Journal of Experimental Biology* **148**: 113-128.
- Müller, U. & Cruse, H. 1991. The contralateral coordination of walking legs in the crayfish *Astacus leptodactylus*. *Biological Cybernetics* **64**: 429-436.
- Mulloney, B., Hall, W.M., Serff, C.M., Braun-Weninger, G. & Chrachri, A. 1991. Innervation of the swimmerets of crayfish: a pair of modular pattern-generating circuits in each abdominal ganglion. *Society for Neuroscience Abstracts* **17**(2): 1389.
- Nelson, G. & Platnick, N. 1981. *Systematics and Biogeography: Cladistics and Vicariance*. New York: Columbia University Press.
- Neruda, P. 1950. Los enigmas. *Canto General II*. Buenos Aires: Editorial Losada, S.A.
- Novacek, M.J. 1994. Morphological and molecular inroads to phylogeny. In: L. Grande & O. Reippel (eds.), *Interpreting the Hierarchy of Nature: From Systematic Patterns to Evolutionary Process Theories*, pp. 85-131. San Diego: Academic Press.
- Parsons, D.W. 1982. The leg flexor muscle of *Carcinus*. I. Innervation and excitatory neuromuscular physiology. *The Journal of Experimental Zoology* **224**: 157-168.
- Pasztor, V.M. & Clarac, F. 1983. An analysis of waving behaviour: an alternative motor programme for the thoracic appendages of decapod crustacea. *The Journal of Experimental Biology* **102**: 59-77.
- Patterson, C. 1982. Morphological characters and homology. In: K.A. Joysey & A.E. Friday (eds.), *Problems of Phylogenetic Reconstruction (Systematics Association Special Volume 21)*, pp. 21-74. London & New York: Academic Press.
- Paul, D.H. 1971a. Swimming behavior of the sand crab, *Emerita analoga* (Crustacea, Anomura) I. Analysis of the uropod stroke. *Zeitschrift für vergleichende Physiologie* **75**: 233-258.
- Paul, D.H. 1971b. Swimming behavior of the sand crab, *Emerita analoga* (Crustacea, Anomura) II. Morphology and physiology of the uropod neuromuscular system. *Zeitschrift für vergleichende Physiologie* **75**: 259-285.
- Paul, D.H. 1971c. Swimming behavior of the sand crab, *Emerita analoga* (Crustacea, Anomura) III. Neuronal organization of uropod beating. *Zeitschrift für vergleichende Physiologie* **75**: 286-302.
- Paul, D.H. 1972. Decremental conduction over "giant" afferent processes in an arthropod. *Science* **176**: 680-682.

- Paul, D.H. 1981a. Homologies between body movements and muscular contractions in the locomotion of two decapods of different families. *The Journal of Experimental Biology* 94: 159-168.
- Paul, D.H. 1981b. Homologies between neuromuscular systems serving different functions in two decapods of different families. *The Journal of Experimental Biology* 94: 169-187.
- Paul, D.H. 1989. A neurophylogenetist's view of decapod crustacea. *Bulletin of Marine Science* 45: 487-504.
- Paul, D.H. 1990. Neural phylogeny — its use in studying neural circuits. In: K. Wiese, W.-D. Krenze, J. Tautz, H. Reichert & B. Mulloney (eds.), *Frontiers in Crustacean Neurobiology*, pp. 537-546. Birkhäuser Verlag: Basel.
- Paul, D.H. 1991. Pedigrees of neurobehavioral circuits: tracing the evolution of novel behaviors by comparing motor patterns, muscles, and neurons in members of related taxa. *Brain, Behavior and Evolution* 38: 226-239.
- Paul, D.H. & Faulkes, Z. 1995. Coupling of different locomotor rhythms in sand crabs. Proceedings of the Fourth International Congress of Neuroethology, 3-8 September 1995, Cambridge University, Cambridge, U.K.
- Paul, D.H. & Mulloney, B. 1985. Nonspiking local interneuron in the motor pattern generator for the crayfish swimmeret. *Journal of Neurophysiology* 54: 28-39.
- Paul, D.H. & Paul, M. 1979. "Stretch-receptive" neurons with central somata are associated with the uropods in megalopa of *Emerita analoga* (Crustacea, Anomura). *Canadian Journal of Zoology* 57(10): 2050-2054.
- Paul, D.H. & Wilson, L.J. 1994. Replacement of an inherited stretch receptor by a newly evolved stretch receptor in hippid sand crabs. *The Journal of Comparative Neurology* 350(1): 150-160.
- Pearlstein, E., Cattaert, D. & Clarac, F. 1995. Fictive posture and fictive locomotion are supported by different motoneuronal sets in the crayfish *Procambarus clarkii*. In: M. Burrows, T. Matheson, P.L. Newland & H. Schuppe (eds.), *Nervous Systems And Behaviour: Proceedings of the 4th International Congress of Neuroethology*, pp.461. Stuttgart: Georg Thieme Verlag.
- Pearson, K.G. 1993. Common principles of motor control in vertebrates and invertebrates. *Annual Review of Neuroscience* 16: 265-197.

- Pearson, K. & Fournier, C.R. 1974. Identification of the somata of common inhibitory motoneurons in the metathoracic ganglion of cockroaches. *Canadian Journal of Zoology* 51: 859-866.
- Pellis, S.M. 1983. Development of head and foot coordination in the Australian magpie *Gymnorhina tibicen*, and the function of play. *Bird Behaviour* 4: 57-62.
- Pellis, S.M. 1985. What is 'fixed' in a Fixed Action Pattern? A problem of methodology. *Bird Behaviour* 6: 10-15.
- Pellis, S.M. 1989. Fighting: the problem of selecting appropriate behavior patterns. In: R.J. Blanchard, P.F. Brain, D.C. Blanchard & S. Parmigiani (eds.), *Ethoexperimental Approaches to the Study of Behavior*, pp. 361-374. Dordrecht: Kluwer Academic Publishers.
- Pitman, R.M., Tweedle, C.D., & Cohen, M.J. 1972. Branching of central neurons: intracellular cobalt injection for light and electron microscopy. *Science* 176: 412-414.
- Pond, C.M. 1975. The role of the "walking legs" in aquatic and terrestrial locomotion of the crayfish *Austropotamobius pallipes* (Lereboullet). *The Journal of Experimental Biology* 62: 447-454.
- Rathbun, M.J. 1926. The fossil stalk-eyed crustacea of the Pacific slope of North America. *Smithsonian Institution Bulletin* 138: 1-155.
- Rathmayer, W. & Bévengut, M. 1986. The common inhibitory neuron innervates every leg muscle in crabs. *Journal of Comparative Physiology A* 158: 665-668.
- Rees, G.H. 1959. Larval development of the sand crab *Emerita talpoida* (Say) in the laboratory. *Biological Bulletin* 117(2): 356-370.
- Reichert, H. 1985. The cellular basis of sensorimotor coordination in the flight control system of the locust. In: B.M.H. Bush & F. Clarac (eds.), *Coordination of Motor Behaviour*, pp. 121-140. Cambridge: Cambridge University Press.
- Reilly, Stephen M. 1995. The ontogeny of aquatic feeding behavior in *Salamandra salamandra*: stereotypy and isometry in feeding kinematics. *The Journal of Experimental Biology* 198: 701-708.
- Roberts, A. 1990. How does a nervous system produce behaviour? A case study in neurobiology. *Science Progress* 74: 31-51.

- Ryckebusch, S. & Laurent, G. 1993. Rhythmic patterns evoked in locust leg motor neurons by the muscarinic agonist pilocarpine. *Journal of Neurophysiology* 69(5): 1583-1595.
- Rowell, C.H.F. 1989. The taxonomy of invertebrate neurons: a plea for a new field. *Trends in Neuroscience* 12(5): 169-174.
- Schmitt, W.L. 1921. The marine decapod Crustacea of California with special reference to the decapod crustacea collected by the United States Bureau of Fisheries steamer "Albatross" in connection with the biological survey of San Francisco Bay during the years 1912-1913. *University of California Publications in Zoology* 23: 1-470.
- Schneider, H., Budhiraja, P., Bräunig, P., Walter, I., Peckol, E., Beltz, B.S., & Kravitz, E.A. 1995. Appearance of octopamine-immunoreactive neurons in the developing lobster CNS: Possible correlation to function. In: M. Burrows, T. Matheson, P.L. Newland & H. Schuppe (eds.), *Nervous Systems And Behaviour: Proceedings of the 4th International Congress of Neuroethology*, pp.163. Stuttgart: Georg Thieme Verlag.
- Schram, F.R. 1982. The fossil record and evolution of Crustacea. In: D.H. Bliss (ed.-in-chief), L.G. Abele (ed.), *The Biology of Crustacea, Volume 1: Systematics, the Fossil Record, and Biogeography*, pp. 93-147. New York: Academic Press.
- Schram, F.R. 1986. *Crustacea*. New York: Oxford University Press.
- Schram, F.R., Feldman, R.M., & Copeland, M.J. 1978. The Late Devonian Palaeopalaemonidae and the earliest decapod crustaceans. *Journal of Paleontology* 52: 1375-1387.
- Serène, R. 1979. Description of *Paralbunea manihinei* gen. and spec. nov. (Decapoda, Hippidea, Albuneidae). *Crustaceana, Supplement* 5: 95-99.
- Sillar, K.T., Clarac, F. & Bush, B.M.H. 1987. Intersegmental coordination of central neural oscillators for rhythmic movements of the walking legs in crayfish, *Pacifastacus leniusculus*. *The Journal of Experimental Biology* 131: 245-264.
- Sillar, K.T., Skorupski, P., Elson, R.C. & Bush, B.M.H. 1986. Two identified afferent neurones entrain a central locomotor rhythm generator. *Nature* 323: 440-443.
- Silvey, G.E. 1981. The distal limb motor neurons in the thoracic ganglion of the spiny lobster (*Jasus novaehollandiae*). *The Journal of Comparative Neurology* 200: 579-595.

- Simon, T.W. & Edwards, D.H. 1990. Light-evoked walking in crayfish: behavioral and neuronal responses triggered by the caudal photoreceptor. *Journal of Comparative Physiology A* **166**: 745-755.
- Siwicki, K.K. & Bishop, C.A. 1986. Mapping of proctolinlike immunoreactivity in the nervous system of lobster and crayfish. *The Journal of Comparative Neurology* **243**: 435-453.
- Skorupski, P. & Bush, B.M.H. 1992. Parallel reflex and central control of promotor and receptor motoneurons in crayfish. *Proceedings of the Royal Society of London B* **249**: 7-12.
- Skorupski, P. & Sillar, K.T. 1988. Central synaptic coupling of walking leg motor neurones in the crayfish: implications for sensorimotor integration. *The Journal of Experimental Biology* **140**: 335-379.
- Sleinis, S. & Silvey, G.E. 1980. Locomotion in a forward walking crab. *Journal of Comparative Physiology* **136**: 301-312.
- Smith, K.K. 1994. Are neuromotor systems conserved in evolution? *Brain, Behavior and Evolution* **43**: 293-305.
- Snodgrass, R.E. 1952. The sand crab *Emerita talpoida* (Say) and some of its relatives. *Smithsonian Miscellaneous Collections* **117**(8): 1-34.
- Spirito, C.P. 1970. Reflex control of the opener and stretcher muscles in the cheliped of the fiddler crab, *Uca pugnax*. *Zeitschrift für vergleichende Physiologie* **68**: 211-228.
- Spirito, C.P. 1972. An analysis of swimming behavior in the portunid crab *Callinectes sapidus*. *Marine Behavior and Physiology* **1**: 261-276.
- Stamps, J.A. 1991. Why evolutionary issues are reviving interest in proximate behavioral mechanisms. *American Zoologist* **31**: 338-348.
- Stein, P.P.G. 1985. Neural control of the vertebrate limb: multipartite pattern generators in the spinal cord. In: M.J. Cohen & F. Strumwasser (eds.), *Comparative Neurobiology: Modes of Communication in the Nervous System*, pp. 245-253. New York: John Wiley & Sons.
- Stoppard, T. 1967. *Rozencrantz & Guildenstern Are Dead*. New York: Grove Weidenfeld.
- Striedter, G.F. & Northcutt, R.G. 1991. Biological hierarchies and the concept of homology. *Brain, Behavior and Evolution* **38**(4-5): 177-189.

- Thorpe, W.H. 1951. The definition of some terms used in animal behaviour studies. *Bulletin of Animal Behaviour* 9: 34-40.
- Tinbergen, N. 1963. On aims and methods of ethology. *Zeitschrift für Tierpsychologie* 20: 410-433.
- Trueman, E.R. 1970. The mechanism of burrowing of the mole crab, *Emerita*. *The Journal of Experimental Biology* 53: 701-710.
- van Harreveld, A. 1939. Doubly-, triply-, quadruply- and quintuply-innervated crustacean muscles. *The Journal of Comparative Neurology* 70: 285-296.
- Wainwright, P.C., Sanford, C.P., Reilly, S.M. & Lauder, G.V. 1989. Evolution of motor patterns: aquatic feeding in salamanders and ray-finned fishes. *Brain, Behavior and Evolution* 34: 329-341.
- Wallis, E.J. 1995. *A comparative study of the behaviour and functional morphology in primitive and advanced malacostracan crustaceans*. Ph.D. dissertation, Department of Zoology, University of Melbourne, Melbourne.
- Wenzel, J.W. 1992. Behavioral homology and phylogeny. *Annual Review of Ecology and Systematics* 23: 361-381.
- Whishaw, I.Q. & Pellis, S.M. 1990. The structure of skilled forelimb reaching in the rat: a proximally driven movement with a single distal rotatory component. *Behavioural Brain Research* 41: 49-59.
- Whitehead, A.N. 1933. *Adventures of Ideas*. Cambridge: Cambridge University Press.
- Wiens, T.J. 1976. Electrical and structural properties of crayfish claw motoneurons in an isolated claw-ganglion preparation. *Journal of Comparative Physiology A* 112: 213-233.
- Wiens, T.J. 1982. Small systems of neurons: control of rhythmic and reflex activities. In: D.H. Bliss (ed.-in-chief), D.C. Sandeman & H.L. Atwood (eds), *The Biology of Crustacea, Volume 4: Neural Integration and Behavior*, pp. 193-240. New York: Academic Press.
- Wiens, T.J. 1989. Common and specific inhibition in leg muscles of decapods: sharpened distinctions. *The Journal of Neurobiology* 20(5): 458-469.
- Wiens, T.J. 1990. The inhibitory innervation of the walking leg of the lobster *Homarus americanus*. *Journal of Comparative Physiology A* 167: 43-50.

- Wiens, T.J. 1991. Dual inhibition of the crayfish's closer muscle by the stretcher and common inhibitors. *Society for Neuroscience Abstracts* 17(2): 1389.
- Wiens, T.J. 1993. The closer muscle is a second target for the stretcher inhibitor motoneuron of the crayfish's thoracic limbs. *Journal of Comparative Physiology A* 173: 435-444.
- Wiens, T.J. & Atwood, H.L. 1978. Motoneuron interactions in crayfish claw control: evidence from intracellular recording. *Journal of Comparative Physiology A* 124: 237-247.
- Wiens, T.J. & Govind, C.K. 1990. Innervation of the lobster limb rotator muscle: physiology and fine structure. *The Journal of Experimental Zoology* 253: 252-262.
- Wiens, T.J. & Rathmayer, H.L. 1985. The distribution of the common inhibitory neuron in brachyuran limb musculature. I. Target muscles. *Journal of Comparative Physiology A* 156: 305-313.
- Wiens, T.J. & Wolf, H. 1993. The inhibitory motoneurons of crayfish thoracic limbs: identification, structures, and homology with insect common inhibitors. *The Journal of Comparative Neurology* 336: 261-278.
- Wiens, T.J., Maier, L., & Rathmayer, W. 1988. The distribution of the common inhibitory neuron in brachyuran limb musculature. II. Target fibers. *Journal of Comparative Physiology A* 163: 651-664.
- Wiens, T.J., Pearce, J., & Govind, C.K. 1991. Neuromuscular properties of the quintuply innervated flexor muscle in lobster limbs. *Canadian Journal of Zoology* 69: 477-488.
- Wiersma, C.A.G. 1941. The inhibitory nerve supply of the leg muscles of different decapod crustaceans. *The Journal of Comparative Neurology* 74(1): 63-79.
- Wiersma, C.A.G. 1951. On the innervation of the muscles in the leg of the lobster, *Homarus vulgaris* Milne Edwards. *Archives Néerlandaises de Zoologie* 8(4): 384-392.
- Wiersma, C.A.G. & Ripley, S.H. 1952. Innervation patterns of crustacean limbs. *Physiologia Comparata et Oecologia* 2: 391-405.
- Wiley, E.O. 1981. *Phylogenetics*. New York: Wiley & Sons.

- Williamson, D.I. 1988. Evolutionary trends in larval form. In: A.A. Fincham & P.S. Rainbow (eds.), *Aspects of Decapod Crustacean Biology (Symposia of the Zoological Society of London 59)*, pp. 11-25. Oxford: Clarendon Press.
- Wilson, D.M. 1966. Insect walking. *Annual Review of Entomology* 11: 103-122.
- Wilson, A.H. & Sherman, R.G. 1975. Mapping of neuron somata in the thoracic nerve cord of the lobster using cobalt chloride. *Comparative Biochemistry and Physiology A* 50: 47-50.
- Wilson, L.J. & Paul, D.H. 1987. Tailflipping of *Munida quadraspina* (Galatheidae): conservation of behavior and underlying musculature with loss of anterior contralateral flexor motoneurons and motor giant. *Journal of Comparative Physiology A* 161: 881-890.
- Wine, J.J. & Krasne, F.B. 1982. The cellular organization of crayfish escape behavior. In: D.H. Bliss (ed.-in-chief), D.C. Sandeman & H.L. Atwood (eds), *The Biology of Crustacea, Volume 4: Neural Integration and Behavior*, pp. 241-292. New York: Academic Press.
- Winkler, D.W. & Sheldon, F.H. 1993. Evolution of nest construction in swallows (Hirundinidae): a molecular phylogenetic perspective. *Proceedings of the National Academy of Sciences USA* 90: 5705-5707.
- Wray, G.A. 1995. Punctuated evolution of embryos. *Science* 267: 1115-1116.

Appendix A: Eshkol-Wachman movement notation

Eshkol-Wachman movement notation (EW) was originally developed for dance. It was designed to enable choreographers to write a dance down on paper that dancers could later reconstruct in its entirety, in a manner analogous to a musical score. Many notation systems have been designed and tried over the centuries; since 1928, there has been an average of one new notation system every four years [Hutchinson Guest 1980; Hutchinson Guest 1989]. Currently, there are three prominent notation systems in use: Laban, Benesh, and EW. Overall, Labanotation is perhaps the most widely used notation system in dance, although Benesh notation is quite prominent in ballet. EW has perhaps a more limited following in the dance world, but has proven the most useful of the three in realms outside of dance.

The following description of the notation is based largely on Eshkol [1980]. It is meant to provide an introduction to the basic, core concepts of EW notation, and does not begin to detail how very diverse movements can be recorded on paper (e.g., rotations of limbs, topological relationships between body parts or partners, detailed hand movements, and do so on). A list of EW-related publications can be found in Appendix B (pg. 263).

EW was designed to be a generalised notation system for any movement, not just those of dance. Consequently, it is not specifically tailored for the human form, unlike Benesh or Labanotation. Instead, EW takes the skeleton as its starting point. EW divides the body at its skeletal joints, and the line segment defined by those points is called a "limb." For example, the forearm is a limb in EW, with the wrist and elbow joints defining its endpoints. Similarly, the foot is a limb bounded by the ankle and the end of the toe. With the body simplified by dividing it into a set of imaginary line segments, the next problem is how to express the relationship of those segments in three dimensional space.

If one end of a line segment is held in a fixed position, that fixed point can be thought of as the centre of a sphere whose radius is the length of the line segment, and all the possible positions of the free end of the segment will describe the surface of that sphere. A position on a sphere can be defined by just two coordinate values, such as

latitude and longitude on a globe, for example. EW writes limb positions using such spherical coordinate system. For example, imagine yourself at the center of a circle drawn on the floor. The circle is divided into units of 45° segments (or whatever resolution is appropriate; for this discussion, 45° will equal one unit) which are numbered from 0 to 7, clockwise. Anywhere you point with your arm (except straight up or straight down) will more or less aim towards one of those numbers. A similar situation can be imagined with a vertical circle on a wall: with the bottom ("South Pole") designated by 0, the middle ("Equator") designated by 2, and the top ("North Pole") marked by 4. Together, these circles form an imaginary sphere. Any limb position can be defined by its coordinates relative to this imaginary sphere.

Because a line has two ends, however, which one is used as the center of the sphere? When standing upright, for example, is the upper leg described as originating at the hip and pointing down (to vertical position 0), or originating at the hip and pointing up (to vertical position 4)? The joint which defines the center of the sphere is determined by which joint is "heaviest." When a "heavy" limb moves, it carries along or modifies the path of other "lighter" limbs connected to it. For instance, when one moves the upper arm from the shoulder, it carries along the forearm and the hand. The upper arm is the heaviest limb, the forearm lighter, and the hand to be the lightest. The designation of "light" and "heavy" is not absolute, however, and a light limb can become a heavy limb depending on what it supports. For a person doing a handstand, any movements of the wrist joint would alter the positions of the forearm and upper arm, but the entire rest of the body. In that case, the hand is the heaviest limb. To take another example, in normal walking, the heavy joint alternates between the hip and the ankle: the ankle is heaviest when the foot is placed on the ground, but the hip is heaviest when the foot is lifted off the ground. Descriptions begin with the heaviest limb and proceed to the lightest.

The horizontal and vertical coordinates given by the sphere are written one above the other. The horizontal coordinate is written on the bottom, the vertical position is written above it.

$$\begin{pmatrix} 2 \\ 1 \end{pmatrix}$$

When positions are *read*, however, the horizontal component (the lower) is always read first, so the position above is read as, “one, two.” In the position above, the “1” indicates a clockwise displacement of 45° horizontally, and the “2” a 90° displacement vertically (parallel to the ground). The parentheses indicate that the limb is being described relative to an external system of reference (“absolute space”).

Positions can also be written relative to another part of the body (“bodywise”). In bodywise descriptions, the position of a lighter limb are described in relation to its heavy neighbour(s). For example, no matter where the shoulder moves the upper arm, the forearm will be considered to be in the same *bodywise* position relative to the upper arm. The forearm may be pointing in any direction in absolute space, but still unmoved and in zero position relative to the upper arm. Bodywise coordinates are enclosed in square brackets.

Movements are written on a page. Units of time are represented from left to right, and limbs are written on a different line from top to bottom. Movements consist of a starting position and time, the direction and amount of movement, and the ending position and time. The direction of the movement is given by arrows, and the amount of movement written as a number next to the arrow. The redundancy in the notation means that the third element can always be deduced (and checked) from the values of the other two. In place of “clockwise” and “counterclockwise,” the terms *positive* and *negative* indicate the direction of movement. The coordinate values indicated one the sphere or reference increase during positive (generally clockwise, or dextral) movements, and decrease with negative (usually counterclockwise, or sinistral) movement. A positive movement of two

units (i.e., 90°) in the horizontal plane is indicated as $\overset{2}{\rightarrow}$. Similarly, a negative (i.e., downward) movement of one unit (i.e., 45°) would be written $\downarrow 1$.

Appendix B: An annotated bibliography of Eshkol-Wachman movement notation

This bibliography is highly selective. In particular, the list of works concerning more general aspects of dance notation and EW is incomplete. Instead, I strove to make the list of references about EW's use in animal behaviour as comprehensive as possible. Most of those papers do not focus on EW; in fact, EW is not even mentioned at all in some. I believe, however, that one can see the influence of EW in these papers, whether it is implicit or explicit. I have decided to err on the side of completeness and include more papers rather than fewer. Papers marked with an asterisk (*) contain notes on notation.

Dance and Movement Notation — General

Camurri, A., Morasso, P., Tagliasco, V. & Zaccaria, R. 1986. Dance and movement notation. In: P. Morasso & V. Tagliaso (eds.), *Human Movement Understanding*, pp. 85-124. New York: North-Holland.

[A general article that uses T'ai Chi and Eshkol-Wachman to emphasize two radically different approaches to the problem of representing movement.]

Hutchinson Guest, A. 1984. *Dance Notation: The Process of Recording Movement on Paper*. London: Dance Books.

[An excellent reference for the general history of dance notation by one of the world's authorities on dance literacy. It also includes interesting thoughts on *why* dancers have been so reluctant to use notation, notation as a profession, and so on.]

Hutchinson Guest, A. 1989. *Choreo-Graphics: A Comparison of Dance Notation Systems from the Fifteenth Century to the Present*. New York: Gordon and Breach.

[This book expertly and directly compares the most prominent dance notation systems of past and present, including EW. It gives a balanced and fair account of the advantages and disadvantages of several notation systems.]

Various. 1988. *The Drama Review* 32(4).

[A special issue of *The Drama Review* focusing on dance and movement notation.]

EW — General

- Eshkol, N. 1980. *50 Lessons By Dr. Moshe Feldenkrais*. Tel-Aviv: The Movement Notation Society.
[Contains the clearest, most concise, most complete exposition of EW currently available.]
- Eshkol, N. 1990. *Angles and Angels*. Tel-Aviv: The Movement Notation Society.
[Contains notes on recent additions to the notational "language."]
- Eshkol, N. & Wachmann (sic), A. 1958. *Movement Notation*. London: Weidenfield & Nicholson.
[The original exposition of Eshkol-Wachman movement notation. It is still useful, although the notation system has evolved considerably since its publication. Note that subsequent EW publications spell "Wachmann" as "Wachman"; the latter spelling is adopted here.]

EW — Animal Behaviour

- Blumberg-Feldman, H. & Eilam, D. 1995. Postnatal development of synchronous stepping in the gerbil (*Gerbillus dasyurus*). *The Journal of Experimental Biology* **198**: 363-372.
- Cools, A.R., Scheenen, W., Eilam, D., & Golani, I. 1989. Evidence that apomorphine and (+)-amphetamine produce different types of circling in rats. *Behavioral Brain Research* **34**: 111-116.
- * Eilam, D. 1994. Influence of body morphology on turning behavior in carnivores. *Journal of Motor Behavior* **26**(1): 3-12.
[This paper is notable for its comparative aspect: three different mammals were studied.]
- * Eilam, D. & Golani, I. 1988. The ontogeny of exploratory behavior in the house rat (*Rattus rattus*): the mobility gradient. *Developmental Psychobiology* **21**(7): 679-710.
- Eilam, D., Golani, I. & Szechtman, H. 1989. D₂-agonist quinpirole induces perseveration of routes and hyperactivity but not perseveration of movements. *Brain Research* **490**: 255-267.
- Eisenberg, J.F. & Golani, I. 1977. Communication in Metatheria. In: T.A. Sebeok (ed.), *How Animals Communicate*, pp. 575-599. Bloomington: Indiana University Press.

- Faulkes, Z., Paul, D.H. & Pellis, S.M. 1991. Digging by the sand crab *Blepharipoda occidentalis*. *Society for Neuroscience Abstracts* 17(2): 1245.
[First use of EW to describe an invertebrate's behaviour.]
- Fentress, J.C. 1981. Order in ontogeny: relational dynamics. In: K. Immelman, G.W. Barlow, L. Petrinovich & M. Main (eds.), *Behavioural Development: The Bielefeld Interdisciplinary Project*, pp. 338-371. Cambridge: Cambridge University Press.
- Fentress, J.C. 1984. The development of coordination. *Journal of Motor Behavior* 16(2): 99-134.
- Fentress, J.C. 1990. Organizational patterns in action: local and global issues in action pattern formation. In: G.M. Edelman, W.E. Gall & W.M. Cowan (eds.), *Local and Global Order in Perceptual Maps*, pp. 357-382. New York: John Wiley & Sons Ltd.
- Ganor, I. & Golani, I. 1980. Coordination and integration in the hindleg step cycle of the rat: kinematic synergies. *Brain Research* 195: 57-67.
- * Golani, I. 1976. Homeostatic motor processes in mammalian interactions: a choreography of display. In: P.P.G. Bateson & P.H. Klopfer (eds.), *Perspectives in Ethology, Volume 2*, pp. 69-134. New York: Plenum Press.
[Golani's seminal paper introducing EW to ethologists.]
- Golani, I. 1981. The search for invariants in motor behaviour. In: K. Immelman, G.W. Barlow, L. Petrinovich & Main, M. (eds.), *Behavioural Development: The Bielefeld Interdisciplinary Project*, pp. 372-390. Cambridge: Cambridge University Press.
- Golani, I. 1992. A mobility gradient in the organization of vertebrate movement: the perception of movement through symbolic language. *Behavioral and Brain Sciences* 15(2): 249-308.
[This paper summarizes much of the work by Ilan Golani and his colleagues since the publication of his 1976 *Perspectives in Ethology* paper. As usual for *Behavioral and Brain Sciences* papers, this reference contains a "target" article by Golani, a set of short commentary articles (which are not listed separately in this bibliography), and Golani's response to the commentaries (continued in Golani 1994). The discussion here is a useful starting point to the whys and wherefores of EW's ethological use.]
- Golani, I. 1994. Continuing commentary on "A mobility gradient in the organization of vertebrate movement: The perception of movement through symbolic language." *Behavioral and Brain Sciences* 17(4): 752-757.

- Golani, I., Bronchti, G., Moualem, D. & Teitelbaum, P. 1981. "Warm-up" along dimensions of movement in the ontogeny of exploration in rats and other infant mammals. *Proceedings of the National Academy of Science USA* 78(11): 7226-7229.
[A useful comparative paper, examining three different mammalian species.]
- * Golani, I., Eshkol, N. & Seidel, S. 1969. *The Golden Jackal*. Tel-Aviv: The Movement Notation Society.
[Out of print.]
- Golani, I. & Fentress, J.C. 1985. Early ontogeny of face grooming in mice. *Developmental Psychobiology* 18(6): 529-544.
- Golani, I. & Moran, G. 1983. A motility-immobility gradient in the behavior of the "inferior" wolf during "ritualized fighting." In: J.F. Eisenberg & D.G. Kleiman (eds.), *Advances in the Study of Mammalian Behavior*, pp. 65-94. American Society of Mammalogists, Special Publication Number 7.
- * Golani, I., Wolgin, D.L. & Teitelbaum, P. 1979. A proposed natural geometry of recovery from akinesia in the lateral hypothalamic rat. *Brain Research* 164: 237-267.
- Havkin, Z. & Fentress, J.C. 1985. The form of combative strategy in interactions among wolf pups. *Zeitschrift für Tierpsychologie* 68: 177-200.
- * Jacobs, W.J., Blackburn, J.R., Buttrick, M., Harpur, T.J., Kennedy, D., Mana, M.J., MacDonald M.A., McPherson, L.M., Paul, D. & Pfau, J.G. 1988. Observations. *Psychobiology* 16(1): 3-19.
[This paper details the difficulty of making scientific observations using ordinary language, and focuses on EW as one possible means of studying behaviour using a formal descriptive system.]
- Moran, G., Fentress, J.C. & Golani, I. 1981. A description of relational patterns of movement during 'ritualized fighting' in wolves. *Animal Behaviour* 29: 1146-1165.
- * Pellis, S.M. 1981. A description of social play in the Australian magpie *Gymnorhina tibicen* based on Eshkol-Wachman movement notation. *Bird Behaviour* 3: 61-79.
[First use of EW with a non-mammalian species.]
- * Pellis, S.M. 1982. An analysis of courtship and mating in the Cape Barren goose *Cereopsis novahollandiae* Latham based on the Eshkol-Wachman movement notation. *Bird Behaviour* 4: 30-41.

- Pellis, S.M. 1983. Development of head and foot coordination in the Australian magpie *Gymnorhina tibicen*, and the function of play. *Bird Behaviour* 4: 57-62.
- Pellis, S.M. 1984. Two aspects of play-fighting in a captive group of Oriental small-clawed otters *Amblonyx cinerea*. *Zeitschrift für Tierpsychologie* 65: 77-83.
- Pellis, S.M. 1985. What is 'fixed' in a Fixed Action Pattern? A problem of methodology. *Bird Behaviour* 6: 10-15.
- Pellis, S.M. 1989. Fighting: the problem of selecting appropriate behavior patterns. In: R.J. Blanchard, P.F. Brain, D.C. Blanchard & S. Parmigiani (eds.), *Ethoexperimental Approaches to the Study of Behavior*, pp. 361-374. Dordrecht: Kluwer Academic Publishers.
- Szechtman, H., Ornstein, K., Hofstein, R., Teitelbaum, P. & Golani, I. 1980. Apomorphine induces behavioral regression: a sequence that is the opposite of neurological recovery. In: E. Usdin, T.L. Sourkes & M.B.H. Youdim (eds), *Enzymes and Neurotransmitters in Mental Disease*, pp. 511-517. New York: John Wiley & Sons Ltd.
- * Szechtman, H., Ornstein, K., Teitelbaum, P. & Golani, I. 1985. The morphogenesis of stereotyped behavior induced by the dopamine receptor agonist apomorphine in the laboratory rat. *Neuroscience* 14(3): 783-798.
- * Wishaw, I.Q. & Pellis, S.M. 1990. The structure of skilled forelimb reaching in the rat: a proximally driven movement with a single distal rotatory component. *Behavioural Brain Research* 41: 49-59.
- Wishaw, I.Q., Pellis, S.M., Gorny, B.P. & Pellis, V.C. 1991. The impairments in reaching and the movements of compensation in rats with motor cortex lesions: an endpoint, videorecording, and movement notation analysis. *Behavioural Brain Research* 42: 77-91.
- * Yaniv, Y. & Golani, I. 1987. Superiority & inferiority: a morphological analysis of free and stimulus bound behaviour in honey badger (*Mellivora capensis*) interactions. *Ethology* 74: 89-116.

Miscellany

The Movement Notation Society is the official organization devoted to Eshkol-Wachman movement notation and is the home of Noa Eshkol's Chamber Dance Group. They publish and sell books on notation.



The Movement Notation Society
75 Arlozorov Street
Holon 58483
Israel

Appendix C: Video synchronisation

Figure C.1 is a schematic of the video/EMG synchronisation device I used to correlate simultaneous video and physiological recording. The device strips a signal from the video camera and outputs a 30 Hz square wave signal that is exactly correlated with each frame of video. The event marker turns on a light visible in the video frame and simultaneously overlays a 1 kHz square wave on the 30 Hz signal. This video-sync was designed by Roberto Racca and built by Pat Kerfoot.

Figure C.1

Schematic diagram of video synchronisation device. Drawn by Pat Kerfoot.

