

**The Characterization and Dating of Landslides  
in the Tsitika River and Schmidt Creek Watersheds,  
Northern Vancouver Island,  
British Columbia**

by

Richard H. Guthrie  
B.Sc., University of Calgary, 1992

A Thesis Submitted in Partial Fulfillment of the  
Requirements for the Degree of

Master of Science

in the School of Earth and Ocean Sciences

We accept this thesis as conforming  
to the required standard



---

Dr. Eileen Van der Flier-Keller, Supervisor (School of Earth and Ocean Sciences)



---

Dr. P. T. Bobrowsky, Departmental Member (School of Earth and Ocean Sciences)

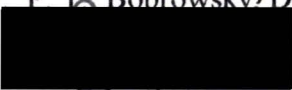

---

Dr. D. J. Smith, Outside Member (Department of Geography)



---

Doug VanDine, Outside Member (VanDine Geological Engineering)



---

Dr. O. Hungr, External Examiner (Department of Earth and Ocean Sciences, University  
of British Columbia)

© Richard H. Guthrie, 1997

University of Victoria

All rights reserved. This thesis may not be reproduced in whole or in part, by photocopy  
or other means, without the permission of the author.

Supervisor: Dr. Eileen Van der Flier-Keller

## **ABSTRACT**

Forty three natural landslide events at 31 landslide sites were examined in the Tsitika River and Schmidt Creek watersheds on Vancouver Island. The watersheds were chosen as a test case, and it is expected that the results will be applicable to similar biogeoclimatic regions on both Vancouver Island and coastal mainland British Columbia. The 365 km<sup>2</sup> study area was divided into eight subdrainages, and landslides were analyzed and compared to one another accordingly.

The landslides examined included debris slides, rockfalls, and rockfall/avalanches. They ranged in size from 7,000 m<sup>2</sup> to 600,000 m<sup>2</sup>, and in volume from 3,200 m<sup>3</sup> to 500,000 m<sup>3</sup>. Approximately 71% of landslide sites deposited sediment directly into a stream channel.

The landslides were distributed over two bedrock types; a granitic intrusive body (Island Intrusives) and layered volcanics (Karmutsen Volcanics). Debris slides were most likely to occur over the Karmutsen Volcanics, and to occur on dip slopes. Debris slides, which accounted for 84% of the landslide types, were strongly associated with morainal deposits, typically failing in the initiation zone at the till/bedrock interface.

Rockfall, excluding active rockfalls (talus buildup), accounted for three of the landslides in the study area. They occurred on steep bluffs as a result of jointed or

fractured rock. They were not associated with morainal deposits, nor did they directly affect stream channels.

Rockfall/avalanches accounted for only two of the landslides in the study area, but accounted for approximately 63% (1,000,000 m<sup>3</sup>) of the total volume.

Rockfall/avalanches in the study area have severely impacted streams.

Debris slides are the most frequent contributor of sediment to streams of the landslides examined in this study. Two drainages where this is particularly evident are Schmidt Creek and Thursday Creek.

Landslides in the study area were dated using dendrochronology, air photograph analysis, and archival information. Dates ranged from as young as 1990 to as old as 1386. The landslides examined were typically less than 100 years old.

Precipitation and seismic data were analyzed for this period, and where possible, the occurrence of landslides were correlated to severe events. Landslides were tentatively correlated to three seismic events; they were the 1946 magnitude 7.3 Vancouver Island earthquake, and two great earthquakes, 1300 +/- 130, and 1700. They occurred at similar dates as the rockfall avalanches. A reasonable correlation occurs between landslides and severe storms, where a more severe storm has a greater likelihood of triggering landslides. Specifically, six landslides occurred in 1975, the same year as a severe storm in the study area. Significant dates of other landslides, which occurred the same year as severe storms recorded at Alert Bay include: 1926, 1946, 1963, and 1977. In addition, a storm in 1990 is thought to have been locally severe and resulted in landslides.

## Examiners:

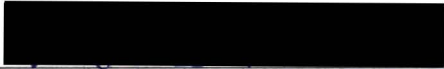

---

Dr. Eileen Van der Flier-Keller, Supervisor (School of Earth and Ocean Sciences)



---

Dr. P. T. Bobrowsky, Departmental Member (School of Earth and Ocean Sciences)



---

Dr. D. J. Smith, Outside Member (Department of Geography)



---

Doug VanDine, Outside Member (VanDine Geological Engineering)

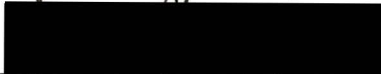

---

Dr. O. Hungr, External Examiner (Department of Earth and Ocean Sciences, University of British Columbia)

## TABLE OF CONTENTS

ABSTRACT	ii
TABLE OF CONTENTS	v
LIST OF FIGURES	viii
LIST OF TABLES	xi
ACKNOWLEDGMENTS	xii
DEDICATION	xiii
1.0 INTRODUCTION	1
1.1 Hypothesis and Objectives	3
2.0 STUDY AREA	5
2.1 Geology	9
2.1.1 Bedrock and Structural	9
2.1.2 Surficial Geology	14
2.2 Climate and Biogeoclimatic Zones	19
3.0 METHODS	23
3.1 Literature Review	23
3.2 Reconnaissance	23
3.3 Field Work	25
3.3.1 Physical Features	26
3.4 Dendrochronology	29
3.4.1 Minimum ages	30
3.4.2 Scars	34
3.4.3 Release Growth	36
3.5 Precipitation Data	36
3.6 Seismic Data	39
4.0 LITERATURE REVIEW	40
4.1 Definitions	40
4.2 Previous Work	49
4.2.1 Queen Charlotte Islands	49
4.2.2 Vancouver Island	52

4.2.3 Tsitika watershed	54
4.3 Trigger Mechanisms	56
4.4 Dendrochronology	59
5.0 RESULTS	60
5.1 Movement Type and Distribution	60
5.2 Azimuth	65
5.3 Initial Elevation	69
5.4 Gradient	71
5.5 Runout	75
5.6 Area	76
5.7 Volume	84
5.7.1 Volume to Stream	88
5.8 Precipitation	91
5.9 Seismic	93
5.10 Landslide Dates	100
5.10.1 Landslide Dates and Precipitation Events	105
5.10.2 Landslide Dates and Seismic Events	108
6.0 DISCUSSION	110
6.1 Debris Slides	110
6.2 Rockfalls	114
6.3 Rockfall/avalanches	115
6.4 Subdrainages	117
6.4.1 Schmidt Creek	117
6.4.2 Thursday Creek	118
6.4.3 Tsitika River	119
6.4.4 Catherine Creek	120
6.4.5 Claude Elliott Creek	121
6.4.6 Tsitika Lake	123
6.4.7 Mount Elliott	123
6.4.8 Russell Creek	124
6.5 Landslide Dates	124
6.5.1 Correlation of Dates with Precipitation	127
6.5.2 Seismic Activity and Dates of Landslides	129
7.0 CONCLUSIONS AND RECOMMENDATIONS	130
8.0 REFERENCES	134

APPENDIX I

148

APPENDIX II

150

## LIST OF FIGURES

Figure 2.1	Location map of the study area.	6
Figure 2.2	The Tsitika study area and its subdrainages.	7
Figure 2.3	A topographic map of the study area.	8
Figure 2.4	A bedrock geology map of the study area.	10
Figure 2.5	The Victoria Arch.	12
Figure 2.6	A surficial geology map of the study area.	15
Figure 2.7	Photograph showing morainal deposit in the study area.	17
Figure 2.8	Mean precipitation and temperature at Alert Bay.	21
Figure 3.1	A landslide as seen from an air photograph.	31
Figure 3.2	The same landslide six years later.	31
Figure 3.3	A tree core from the bark to the pith.	33
Figure 3.4	Extrapolation of a pith from a tree core.	33
Figure 3.5	Dating an event based using a tree scar.	35
Figure 3.6	Coring a tree scar correctly.	35
Figure 3.7	Identifying release growth in a tree core.	37
Figure 4.1	A model of forces acting on a particle on a slope.	42
Figure 4.2	Varnes (1978) classification of landslides.	42
Figure 4.3	Photograph of a debris slide.	45
Figure 4.4	Profile of a debris slide.	45
Figure 4.5	Photograph of a rockfall.	47

Figure 5.1	Location of landslides in the study area.	62
Figure 5.2	Location of active mass movements in the study area.	64
Figure 5.3	Distribution of landslides relative to bedrock geology.	66
Figure 5.4	Distribution of landslides relative to surficial geology.	67
Figure 5.5	Azimuths of landslides compared to geology.	68
Figure 5.6	Initial elevation vs. area of landslides.	72
Figure 5.7	Gradients of landslides.	74
Figure 5.8	Landslide areas.	77
Figure 5.9	Distribution of landslide areas in the study area.	78
Figure 5.10	Landslide areas compared with bedrock geology.	79
Figure 5.11	Landslide areas compared with surficial geology.	80
Figure 5.12	Landslide volumes.	85
Figure 5.13	Comparison between landslide areas and volumes.	86
Figure 5.14	The distribution of landslide volumes in the study area.	87
Figure 5.15	Comparison of landslide volumes to streams in the study area.	90
Figure 5.16	One day maximum annual precipitation for 73 years of record at Alert Bay.	94
Figure 5.17	Locations of earthquakes which resulted in ground movement of $10\text{cm/s}^2$ or greater in the study area.	96
Figure 5.18	Isoseismal map of the 1918 earthquake.	98
Figure 5.19	Isoseismal map of the 1946 earthquake.	99
Figure 5.20	Dates of landslides in the Tsitika study area.	101

Figure 5.21	The spatial distribution of recurring landslides.	103
Figure 5.22	Landslides coincident with the 1975 storm.	106
Figure 5.23	Landslides coincident with storms with return intervals from 1:25 - 1:50 years.	107
Figure 5.24	Landslides coincident with seismic events.	109

## LIST OF TABLES

Table 2.1	Drainage and subdrainage basin areas.	5
Table 2.2	Distribution of surficial sediments.	19
Table 3.1	List of air photographs for the Tsitika study area.	24
Table 5.1	Distribution of landslides by subdrainage.	63
Table 5.2	Landslides per 150m of elevation.	70
Table 5.3	Initial elevation of landslides compared to subdrainage.	70
Table 5.4	Distribution of landside gradients in the study area.	73
Table 5.5	Area statistics for landslide types in the study area.	76
Table 5.6	Distribution of landslide areas in the study area.	81
Table 5.7	Distribution of landslide areas relative to bedrock and surficial geology.	82
Table 5.8	Amount of sediment into stream channels.	89
Table 5.9	Distribution of landslide volumes to streams in the study area.	89
Table 5.10	Frequency analysis of precipitation at Alert Bay and Sayward.	92
Table 5.11	Return intervals at Alert Bay less than 10 years.	95
Table 5.12	Seismic activity which resulted in movements greater than $10\text{cm/s}^2$ in the Tsitika study area.	95

## ACKNOWLEDGMENTS

Numerous people have contributed to both the following thesis and to my program. I am grateful to my supervisor, Dr. Eileen Van der Flier-Keller, for her support and patience through both. I am indebted to my committee for the tremendous amount of time they put into the numerous final drafts of this product. Sound advise, comments and general ideas from Dr. Peter Bobrowsky and Doug VanDine regarding all aspects of landslides and landslide analysis, as well as patient and thorough reviews of my documents were particularly helpful.

Gratitude is extended as well to Mike Miles of M. Miles and Associates for the precipitation analysis, and to Bob Horner and Dieter Weichert at the Pacific Geoscience Centre for seismic analysis. Field work was made considerably easier by logistical support from the folks at Eve River Division of MacMillan Bloedel, and at Englewood Division of Canadian Forest Products. They provided helicopter time, air photographs, maps and archived information which made the entire project a realistic endeavor.

Funding for the project came primarily from a service contract provided by the Ministry of Forests Research Branch through Steve Chatwin, and administered by Terry Rollerson of the Vancouver Forest Region. Additional funding was provided by a National Science and Engineering Research Council grant to Dr. Eileen Van der Flier-Keller, as well as graduate grants and teaching assistant positions provided by the University of Victoria.

Finally I would like to thank Michael Vincent, for his able assistance in the field, and Jan Schuh, for her continual assistance over the entire duration of this project.

**DEDICATION**

This thesis is dedicated to my grandfather Eric L. Kenny. His honour and integrity have been, and continue to be, an inspiration to me every day.

## 1.0 INTRODUCTION

Mass movement is a term describing all the various processes that move sediment downslope under the influence of gravity. These processes include sliding, flowing, creeping, slumping, and toppling of rock and soil (Varnes, 1978). Collectively, mass movements are often generalized and called landslides. Landslides are common in the Canadian Cordillera, and range in size from less than  $10 \text{ m}^3$  to greater than  $10^6 \text{ m}^3$  (Clague, 1989). Landslides typically remove sediment from steep upper slopes, and deposit them in a more stable downslope location. In steep mountainous areas, mass movements have significant impact on both upper and lower slopes. Landslides modify slope morphology and may result in the removal of all vegetation from a site. They alter local topography often impacting rivers and lakes, and potentially have far-reaching effects on such systems (Hogan and Schwab, 1991a). Impacts on rivers and lakes may include the addition of sediment, the relocation, or complete blockage of the feature.

Landslides are considered a serious hazard in coastal British Columbia, including Vancouver Island. Glacially over-steepened slopes, poorly consolidated soils (till and colluvium) overlying relatively impermeable bedrock, and high precipitation levels contribute to the extensive mass wasting. In addition to receiving high levels of precipitation, western British Columbia is also considered one of the most seismically active regions in Canada (Cruden *et al.*, 1989, and Rogers, 1992). Besides windthrow, landslides are considered the most significant disturbance agents in coastal forest succession (Parish and Parminter, 1994). They directly and indirectly affect fish streams, availability of and access to productive timber, road networks, and people. Unfortunately,

little quantitative work has been done to document and evaluate, in terms of frequency and physical characteristics, the impact of natural landslides in a coastal temperate rainforest.

## 1.1 Hypothesis and Objectives

The physical attributes of natural landslides are important in assessing the settings and conditions under which slope instability may occur. Understanding which characteristics are most significant to instability, as well as understanding the natural contribution of mass movements to a watershed, allows the resource managers to make informed land management decisions. This is particularly important in British Columbia, where, under the current legislation of the Forest Practices Code, knowledge of slope stability, and evaluation of landslide hazard is required prior to the approval of logging and road building permits (British Columbia Ministry of Forests, 1995a, 1995b, and 1995c).

This thesis examines landslide characteristics in a typical coastal temperate rainforest region of British Columbia, and attempts to relate landslide activity with causal factors.

Landslide events can be dated with reasonable confidence using dendrochronology. The determined dates may be used to correlate landslides with a particular trigger event. The two most dominant trigger mechanisms in the coastal temperate rainforest region of Vancouver Island are expected to be precipitation and seismic activity. These two trigger mechanisms have been observed in the Pacific Northwest previously by others (Mathews, 1979, Evans 1989a, 1989b, Evans and Clague, 1989, Hogan and Schwab, 1991a, Chatwin and Smith, 1992, and VanDine and Evans, 1992 for example). Given the very steep and poorly consolidated soils in much of this region, mass movements may be triggered by either factor, but two trends are expected: (a) precipitation is likely to have a greater

effect in terms of numbers of mass movements, as it is more frequent at intensities sufficient to induce landsliding, and (b) seismic activity is likely responsible for more events that occur in competent material (e.g., bedrock as compared to moraine).

In order to test these hypotheses, the following objectives were determined:

- (a) to locate and date discrete natural hillslope failures greater than one hectare in area in a watershed in coastal temperate rainforest on Vancouver Island;
- (b) to describe the physical characteristics of landslides and determine the most significant physical factors contributing to their occurrence; and,
- (c) to determine mass-movement volumes and sediment delivery to stream channels; and,
- (d) to determine the age and frequency characteristics of landslides; and,
- (e) to determine possible trigger events using historical climatic and seismic records, and then relate these to the landslide dates.

This study should serve as a model for the occurrence of landslide activity and characteristics for other similar watersheds in the coastal temperate rainforests of British Columbia.

## 2.0 STUDY AREA

The Tsitika study area encompasses approximately 365 km<sup>2</sup> of relatively pristine forest land on northeastern Vancouver Island. It is located approximately 42 km north of Sayward and 37 km south of Port McNeill (Figure 2.1). The study area (Figure 2.2) comprises two distinct watersheds; the Tsitika River and Schmidt Creek, both of which empty directly into Johnstone Strait. The southern most portion of the Tsitika watershed is truncated by TFL boundary 37. This is not expected to affect the results as the truncated portion is physically comparable to the rest of the watershed. The Tsitika River has been divided into seven subdrainages, based on the major tributaries. They include Catherine Creek, Thursday Creek, Claude Elliott Creek and Russell Creek, in addition to an unnamed stream fed by Tsitika Lake, and another unnamed stream that drains an enclosed basin surrounded by high peaks, including Mount Elliott. Table 2.1 lists the sizes of both the drainages and the subdrainages.

Drainage	Subdrainage	Area (km <sup>2</sup> )	% of Total
Tsitika River	Tsitika River	158	43
	Thursday Creek	18	9
	Catherine Creek	50	5
	Claude Elliott Creek	47	14
	Tsitika Lake	7	13
	Mount Elliott	11	2
	Russell Creek	40	3
Schmidt Creek		34	11
Total Area		365	

Table 2.1: Drainage and subdrainage basin areas.

The study area is characterized by steep rugged terrain, ranging in elevation from sea level to more than 1,750 m (Figure 2.3). The Tsitika River follows a broad U-shaped

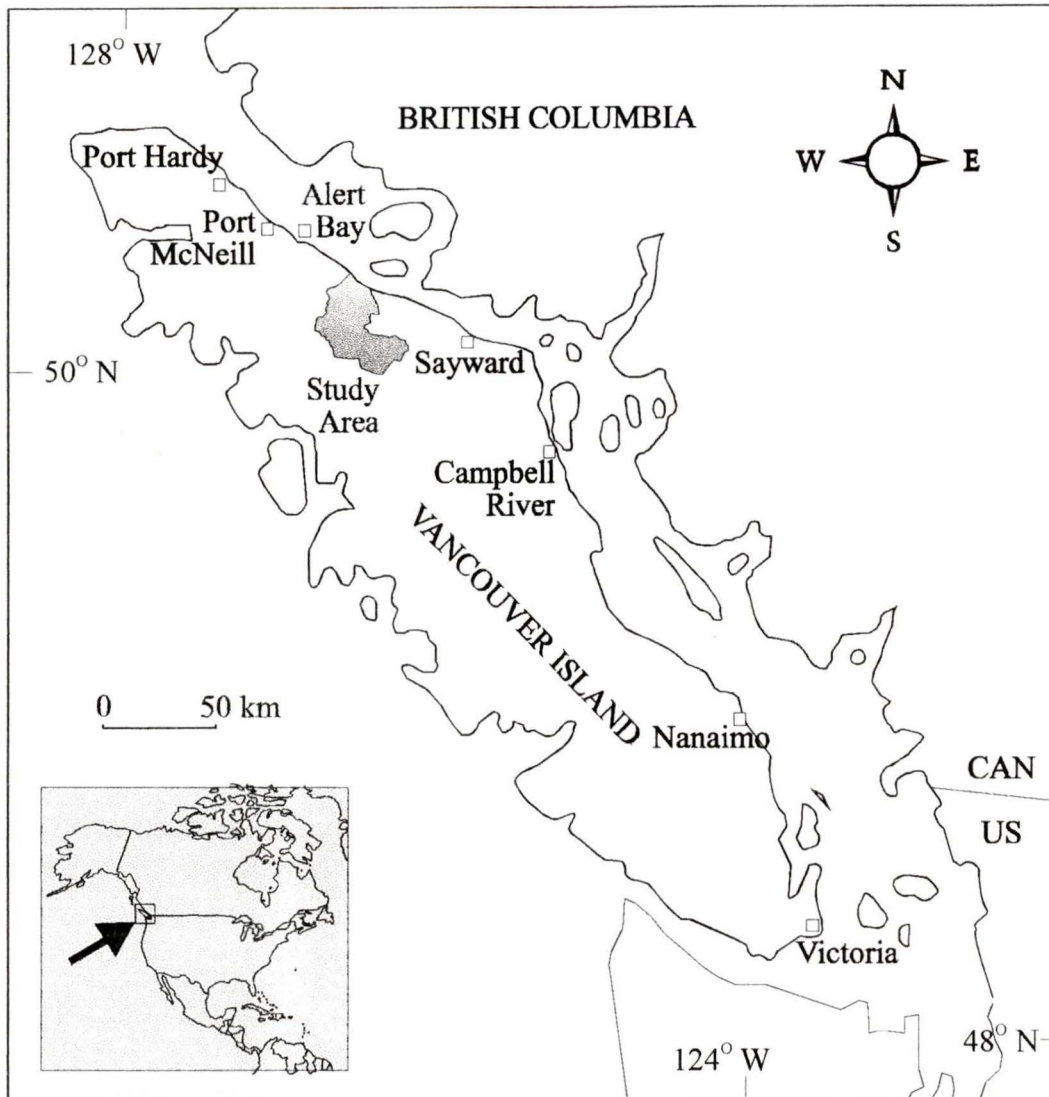

Figure 2.1: Location map of the study area.

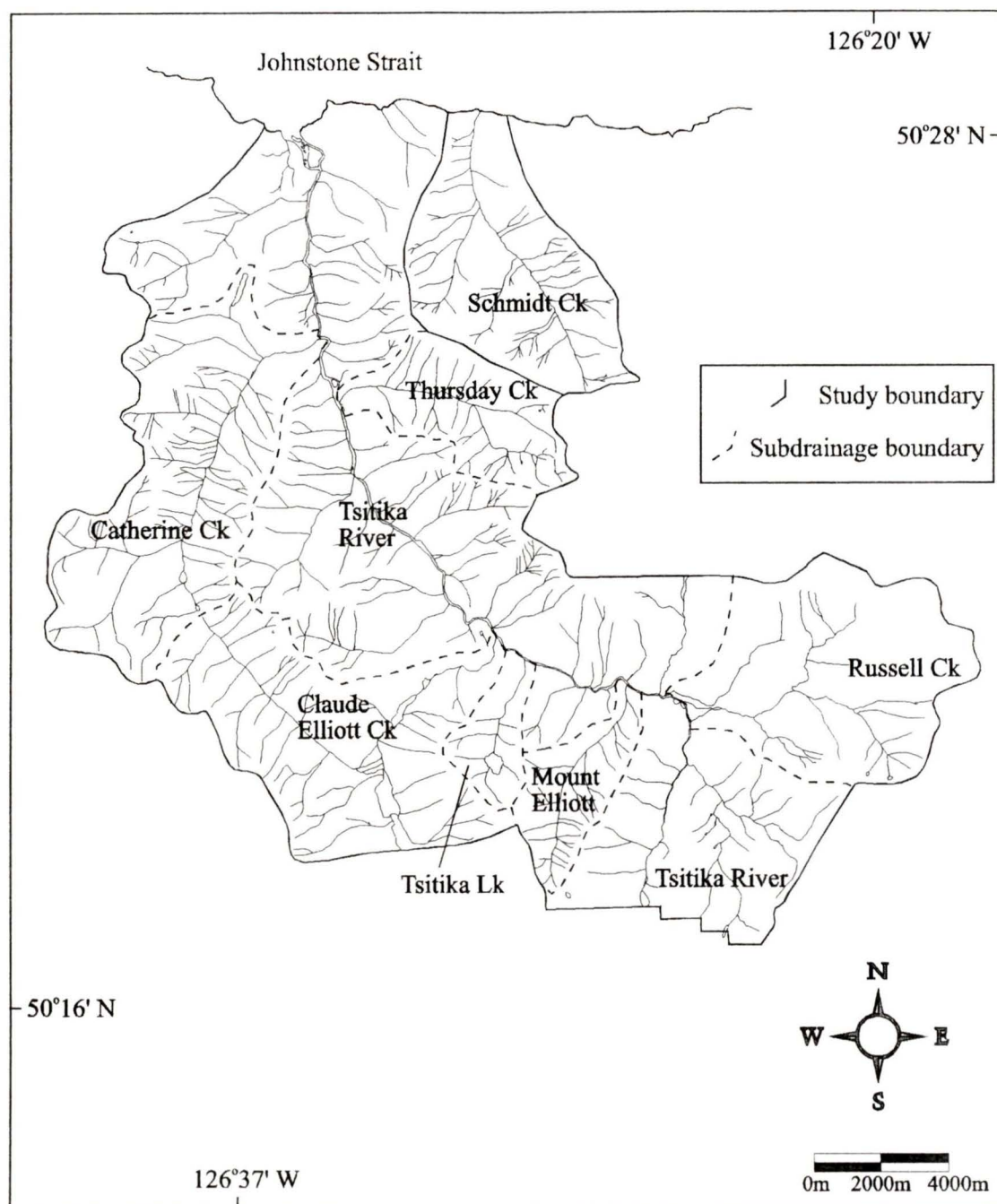

Figure 2.2: The Tsitika study area, drainages and subdrainages.

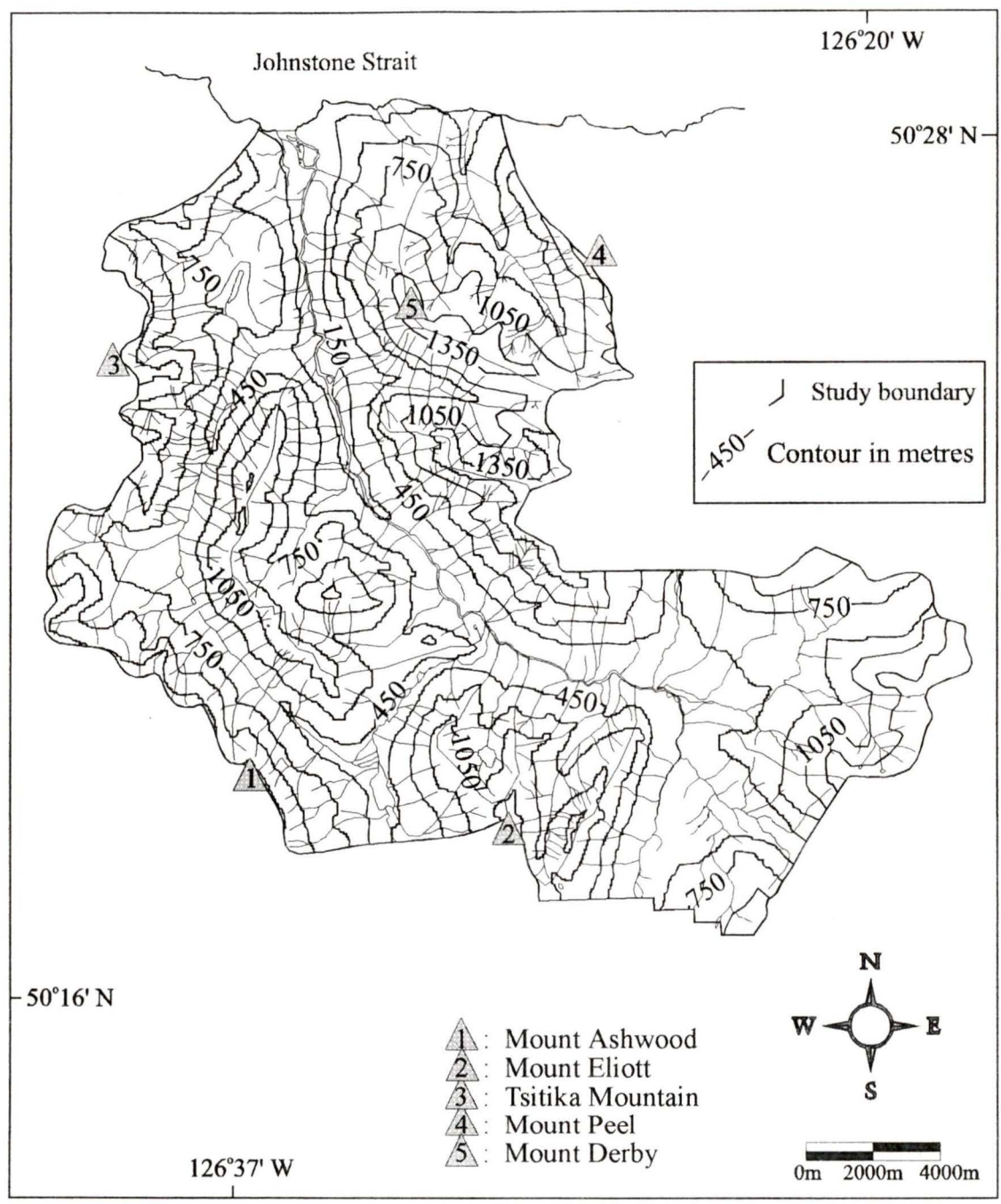

Figure 2.3: A topographic map, showing mountain peaks in and adjacent to the study area.

valley, which bisects the study area, running first north, then west-northwest, and then north-northwest. A number of prominent peaks surround the Tsitika, including Mount Ashwood (1,761 m) and the Bonanza Range to the southwest, Mount Elliott (1,584 m) to the south, Tsitika Mountain (1,667 m) to the northwest, and Mount Peel (1,554 m) and Mount Derby (1,658 m) that join to form an unnamed range that completely surrounds Schmidt Creek to the northeast.

## **2.1 Geology**

### **2.1.1 Bedrock and Structural Geology**

Bedrock geology of the Tsitika is described in Muller *et al.* (1974), Roddick (1980), Howes (1981a), and Geological Survey of Canada map 1552A (Muller and Roddick, 1983). The study area is underlain by two distinct formations; the Upper Triassic Karmutsen Volcanics, and Jurassic age Island Intrusives (Figure 2.4).

The Karmutsen Volcanics are described in detail by Carlisle (1972), Muller *et al.* (1974) and Nixon *et al.* (1994), and represent a thick (6000 m at its thickest) accumulation of both submarine and subareal flood basalts. The volcanics are the most common rock type on both Vancouver Island and the Queen Charlotte Islands and form a major portion of the Wrangellia Terrane in British Columbia (Muller *et al.*, 1974, Yorath and Nasmith, 1995). The Karmutsen Volcanics underlie 57% (209 km<sup>2</sup>) of the study area, and are divided into three main units. The lower and middle units are most common in the

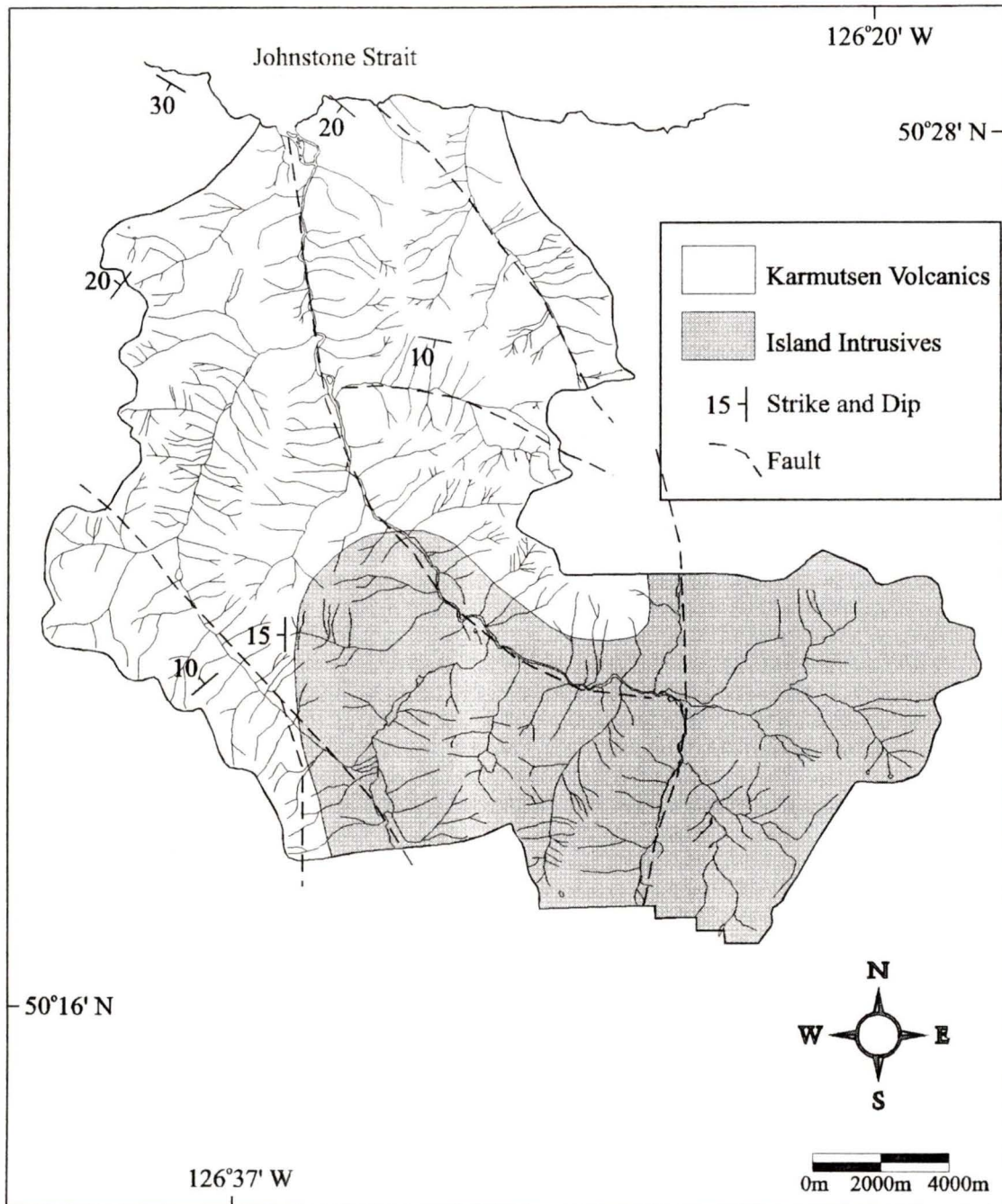

Figure 2.4: The bedrock geology of the Tsitika study area (Muller and Roddick, 1983).

study area, due to the structural uplift of the Victoria Arch (Figure 2.5) described below.

The lowermost unit consists of pillow basalts approximately 2,500 m thick.

Pillows range in shape from rough spheres, 15 cm in diameter, to irregular elongate ellipsoids, up to one and one half metres wide and half a metre high (Muller *et al.*, 1974).

The pillows often have aphanitic chill margins up to about one cm thick, and are commonly porphyritic and amygdaloidal. Intrapillow void spaces are commonly filled with quartz and to a lesser extent pumpellyite and epidote (Muller *et al.*, 1974).

The middle unit ranges in thickness from 600 -1,000 m and is composed of pillow breccias and bedded tuffs. Amygdales are common throughout and are filled with quartz, epidote, prehnite and pumpellyite (Muller *et al.*, 1974, and Nixon *et al.*, 1994). The pyroclastic matrix contains broken feldspar and augite, devitrified glass shards, and altered globules (Muller *et al.*, 1974, and Nixon *et al.*, 1994).

The uppermost unit consists primarily of volcanic flows with minor intervolcanic limestones near the top of the unit. Flows range in thickness from 1.5 - 3 m in some sections and 15 - 30 m in others (Muller *et al.*, 1974). Represented by fine grained basalt, this unit exhibits amygdaloidal piping, with a higher concentration of amygdales near the top of flows (Muller *et al.*, 1974, Nixon *et al.*, 1994).

The Island Intrusives are a Middle Jurassic plutonic complex which have intruded all Vancouver Group rocks (of which the Karmutsen Formation is a member). The Island Intrusives are described in detail by Muller *et al.* (1974), and Nixon *et al.* (1994), and consist primarily of granitic stocks and batholiths, elongated in a northwesterly direction.

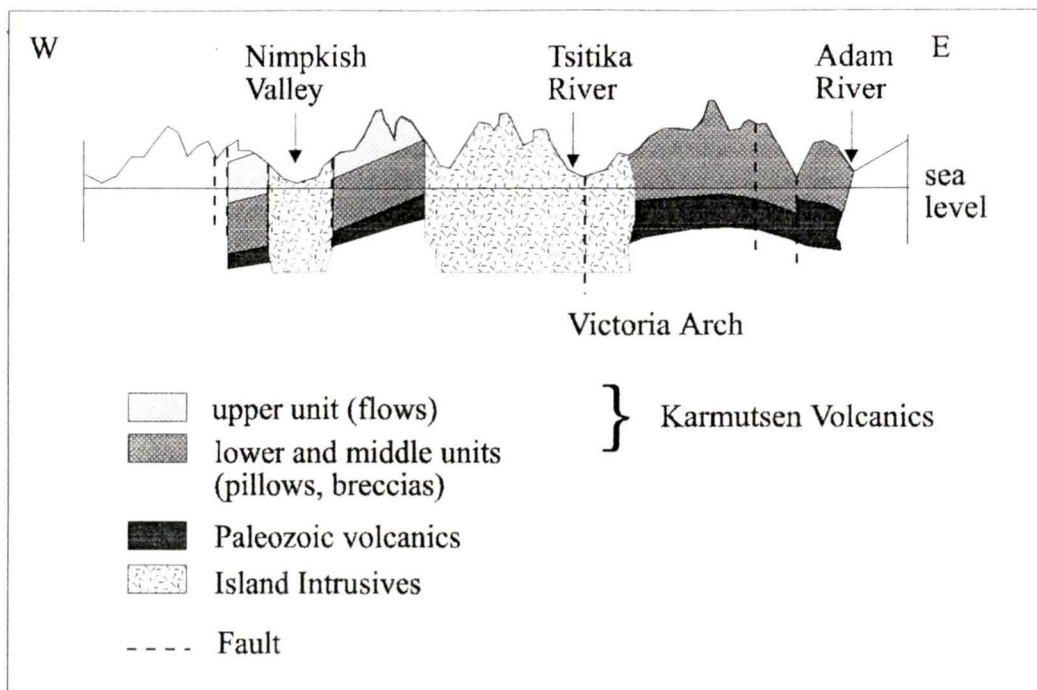

Figure 2.5: The culmination of the Victoria Arch which makes up the backbone of Vancouver Island. The layered units of the Karmutsen formation dip away from the arch on both sides. This results in a westward trending dip in the study area.

(modified from Howes, 1981a, and Muller *et al.*, 1974)

The Island Intrusives are common throughout Vancouver Island and are distributed as numerous separate and joined batholiths. Approximately 43% (156 km<sup>2</sup>) of the Tsitika study area is intruded by a portion of the Vernon Batholith, of the Island Intrusives (Figure 2.4).

The Vernon Batholith is the largest batholith of the Island Intrusives, whose northward extension reaches the headwater area of the Tsitika River (Muller *et al.*, 1974). In the study area it consists of a dark grey biotite-hornblende quartz diorite and granodiorite. The rock is described by Muller *et al.* (1974) as consisting of medium grained (2 - 4 mm) equigranular crystals of subhedral plagioclase, quartz, and lesser amounts of biotite and hornblende.

Northeast Vancouver Island is dominated by a north-northwest trending arch, (Figure 2.5) fractured by vertical block faults (Muller *et al.*, 1974, Howes, 1981a). A number of the streams in the study area are fault controlled. The faults are a result of Wrangellia, which consists of Paleozoic, Upper Triassic and Jurassic aged rocks, accreting into the North American Continent. The dominant fault direction is in a northwesterly direction (Muller *et al.*, 1974). Steep faults on Vancouver Island and the Queen Charlottes are the dominant structural discontinuities between formations.

The Victoria Arch, associated with the emplacement of the Island Intrusives, makes up the backbone of Vancouver Island and culminates directly east of the Tsitika study area (Figure 2.5). Stratigraphic units of the Karmutsen Volcanics dip away from the arch on both sides resulting in regional dip in the study area of 10 - 20 ° in a westerly direction, with local variations in strike ranging from southeast to southwest. The greatest

(mapped) deviation of strike occurs along Thursday Creek (nearly east-west), resulting in southward dipping beds. Dip angle increases regionally outside the study area to about 45° toward the northern end of Vancouver Island.

### **2.1.2 Surficial Geology**

The surficial geology of Northern Vancouver Island is described in Holland (1964), Howes (1981a, 1981b and 1983), and Bobrowsky and Meldrum (1994). For this study surficial geology of the Tsitika study area is derived from Howes (1981a), Maynard (1991), and the following maps:

- ◆ Tsitika River Watershed, Terrain Classification (British Columbia Ministry of Environment, 1978), 1:31,680.
- ◆ Terrain Geology map, NTS 92L/7 (Senyk, 1980), 1:50000
- ◆ Terrain Geology map, NTS 92L/8 (Jungen, 1980), 1:50000

The surficial geology of the Tsitika study area (Figure 2.6) is dominated by the occurrence of morainal deposits from the Fraser glaciation, and by colluvium resulting from the various forms of mass wasting. Vancouver Island was subject to at least three major glaciations during the Pleistocene; the Westlynn glaciation, the Semiahmoo glaciation, and the Fraser glaciation (Ryder and Clague, 1989, Yorath and Nasmith, 1995). In most places, however, traces of the older glaciations have been eroded by the Fraser glaciation that began about 29,000 years ago. On northern Vancouver Island,

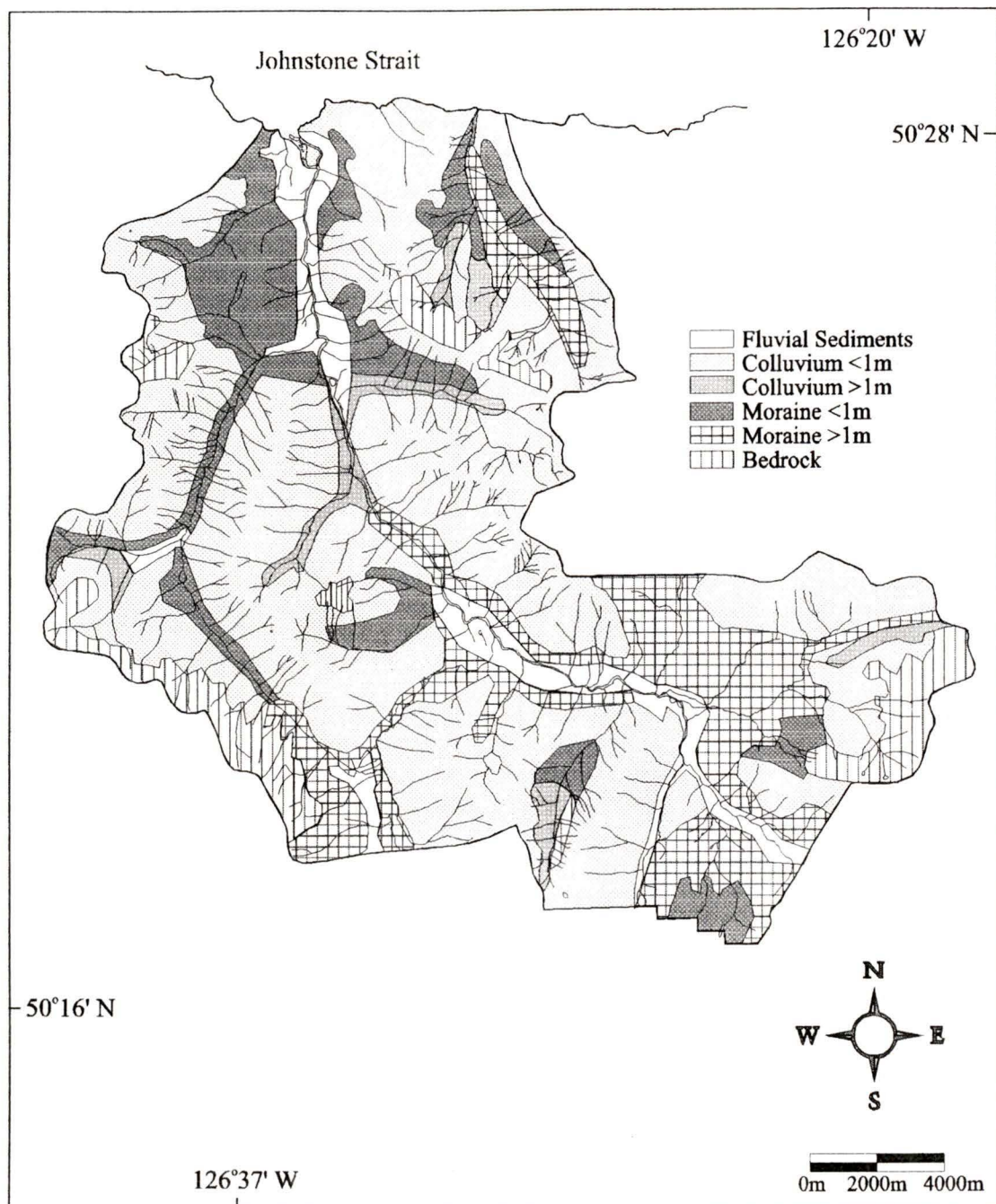

Figure 2.6: Surficial geology of the Tsitika study area (Howes, 1981a, Jungen, 1980 and Senyk, 1980).

evidence exists only for the last two glaciations (Bobrowsky and Meldrum, 1994). Ice from the last major glaciation reached its maximum and began retreating approximately 13,630 +/- 310 years BP (Bobrowsky and Meldrum, 1994). Glaciation has resulted in numerous U-shaped valleys, oversteepened slopes and morainal deposits in the Tsitika study area.

Morainal deposits in the study area are generally medium to coarse textured basal till, composed of a non-calcareous, poorly sorted diamicton of sand and cobbles in a matrix of sand and silt (Howes, 1981a, and Figure 2.7). They range in thickness from less than one metre (morainal veneer) to several metres (morainal blanket). Colour varies from reddish brown to grey in unweathered deposits.

Till in the Tsitika study area is derived from local bedrock (Howes, 1981a) and, therefore, differs somewhat in texture depending on the underlying formation. Till overlying Karmutsen Volcanics is composed of approximately equal portions of sand and silt (+/- 20%) and up to 50% coarse fraction. Till overlying Island Intrusives is typically sandier and up to 60% is coarse fraction. Clay comprises less than 5% of till in the Tsitika study area.

The distribution of morainal deposits in the Tsitika study area is generally limited to mid and lower slopes and thickness tends to decrease upslope. The largest deposition of deep morainal sediment occurs in the southeast portion of the study area, where the topography is more subdued as a result of glaciation.



Figure 2.7: Morainal deposits in the Tsitika study, are generally considered to be a medium to coarse basal till. They are composed of poorly sorted sand, and cobbles, and range in thickness from a thin veneer, to several metres.

Colluvium is the dominant surficial sediment in the Tsitika study area. It is derived from a number of mass wasting processes including frost shattering and downslope creep of bedrock, debris flows, snow avalanches, as well as debris slides, rockfalls and rockfall avalanches (for a complete discussion of these terms, refer to section 4.1). Geomorphic indicators of colluvium include large coalescing fans along the valley floor, talus cones on the upper valley walls, snow avalanche fans, and rockfall avalanche and debris slide deposits. In general, however, colluvium forms a veneer (<1 m) over most of the study area, and is typically found on mid to upper slopes. Deeper deposits are typically found on the lower slopes in the study area.

The texture of colluvial material depends largely on the parent material (bedrock and till) from which it was derived. In general, colluvium derived from Karmutsen Volcanics consists of a matrix of silty sand and a rubbly coarse fraction, whereas colluvium derived from Island Intrusives has a sandier matrix and a coarse fraction ranging from rubbly to bouldery. Colluvial fans, aprons, and cones may be composed of a greater percentage of coarse material than other colluvial deposits (Howes, 1981a).

Fluvial sediments occur along the Tsitika River and as fans at the mouths of both the Tsitika River and Catherine Creek (Figure 2.5). The sediments are typically composed of coarse gravels ranging in size from rubble to boulders, indicative of deposition during periods of high water discharge.

The spatial distribution of surficial sediments in the study area is quantified in Table 2.2.

Type	Area (km <sup>2</sup> )	% of Total
Fluvial sediments	23	6
Colluvium <1 m thick	203	56
Colluvium >1 m thick	13	4
Moraine <1 m thick	44	12
Moraine >1 m thick	56	15
Bedrock	26	7

Table 2.2: Distribution of surficial sediments.

## 2.2 Climate and Biogeoclimatic Zones

Climate in British Columbia can be grouped with soil and vegetation types to form a biogeoclimatic land classification (British Columbia Ministry of Forests, 1992). This standard method of ecological classification is discussed in detail by Klinka *et al.* (1984), and Pojar *et al.* (1987), and is outlined on the 1:500,000 map Biogeoclimatic Units of the Vancouver Forest Region (Nuszdorfer *et al.*, 1985).

The nearest long term weather station to the study area is at Alert Bay (Figure 2.1) (Environment Canada, 1993). Data are available from 1913-1990. Mean daily temperature at Alert Bay is 8.5 C° with mean daily range from 5.4 - 11.6 C°. On average, 361 days a year have maximum temperatures above 0 C°, indicating the moderating coastal influence. Precipitation is high relative to most of British Columbia and Canada, raining on average 202 days per year, mostly from mid-fall to mid-spring. Extreme rainfall

statistics suggest that storms are about five times as severe (in terms of total precipitation falling in 24 hours) as storms in the interior of British Columbia (Hogg and Carr, 1985). Total annual precipitation at Alert Bay averages 1,609.5 mm, with less than 5% measured as snowfall. Figure 2.8 shows mean monthly temperatures and precipitation at Alert Bay.

The Tsitika study area is characterized by two Biogeoclimatic zones; the Coastal Western Hemlock zone and the Mountain Hemlock zone. Both zones are widespread throughout Vancouver Island. The Coastal Western Hemlock zone is generally found at elevations lower than the Mountain Hemlock zone, although elevations depend on location. The Mountain Hemlock zone is generally found above 800 -900 m in the study area, and the Coastal Western Hemlock zone is found below this elevation range. The Coastal Western Hemlock zone is further divided into the Windward Submontane Maritime variant, and the Windward Montane Maritime variant. The Mountain Hemlock zone is divided in the study area, into the Maritime Forested subzone, and a subzone of undifferentiated Alpine Tundra and Mountain Hemlock. All four subzones exhibit a close relationship with elevation.

Coastal Western Hemlock; Windward Submontane Maritime is characterized by a climax species of coastal Western Hemlock (*Tsuga heterophylla*). Soils are often podzolic and precipitation during the driest month typically exceeds 80 mm (Klinka *et al.*, 1984). Summers are warm and winters mild. This subzone occurs up to about 600 m. The Windward Montane Maritime variant is similar to temperature regimes expected

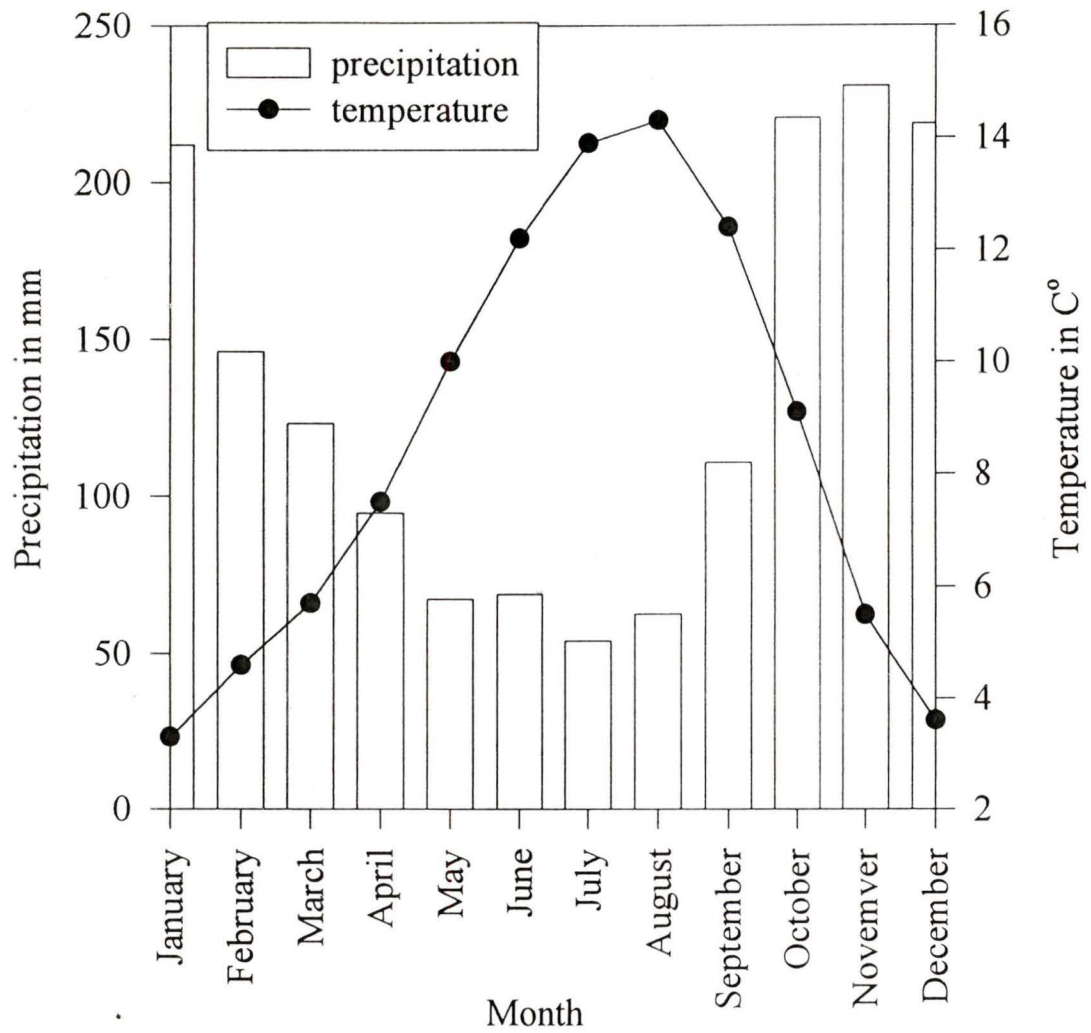

Figure 2.8: Mean monthly precipitation and temperature at Alert Bay, 1913-1990 (Environment Canada, 1993).

to be intermediate between the Submontane variant and the Mountain Hemlock; Maritime Forested subzone. It is found to occur above the Submontane variant, to 800 - 900 m.

Mountain Hemlock zone; Maritime Forested subzone is characterized by a climate climax species of Mountain Hemlock (*Tsuga mertensiana*). Soils are generally podzolic and precipitation is similar to the Coastal Western Hemlock zone, except that almost 30% of precipitation may accumulate as snow (Klinka *et al.*, 1984). Winter mean temperatures are commonly below freezing, and snow may persist into June.

The Alpine Tundra is a non-forested ecosystem found on high mountains. It is characterized by a low temperature regime, a short growing season and approximately 70% of precipitation falling as snow (Klinka *et al.*, 1984). The Alpine Tundra is generally associated with elevations of about 1,300 m and above.

## **3.0 METHODS**

### **3.1 Literature review**

A review of the literature was undertaken to evaluate the extent of background work and related topics. Topics reviewed include classification of landslides, occurrence of landslides and their impacts in Pacific Northwest, dendrochronology and its application to geomorphic events, trigger mechanisms, and factors influencing the occurrence of landslides. The results of the literature review are presented in section 4.0.

### **3.2 Reconnaissance**

Discrete open slope landslides larger than one hectare were examined for this study. Landslide size was chosen to match work in progress by Schwab (unpublished) in the Prince Rupert Forest Region. Five landslides slightly smaller than one hectare (7,000 - 9,500 m<sup>2</sup>) but with similar characteristics were also included in the study. Prior to the field work, a landslide inventory, using air photographs ranging in scale from 1:15,000 to 1:70,000 was completed. Table 3.1 lists the air photographic data sets, their scale and sources. Identification of landslides from air photographs was based on standard practice, described by Swanston and Howes (1994a). Indicative morphological features such as scarps, stream displacement, bare or newly vegetated linear tracks, fans, cones and other

Agency	Year	Approx. scale	Air photo Line and number
Maps BC	1953	1:31,680	BC1711, 103-106; BC1569, 2-5, 32-56, 87-93; BC1571, 67-79
Maps BC	1967	1:31,680	BC5260, 160-165, 185-205, 230-235
Maps BC	1972	1:63,360	BC5501, 176-182; BC5493, 157-160, 200-204, 244-248
Maps BC	1974	1:63,360	BC5631, 185-190, 233-236; BC5641, 187-192
Maps BC	1976	1:50,000	BC5749, 24-31, 73-80, 150-154
Maps BC	1978	1:20,000	BC78080, 102-112, 154-166, 205-217
Maps BC	1981	1:20,000	BC81082, 34-42, 45-53, 86-92, 95-104, 137-146; BC81091, 52-61, 66-75, 121-130, 133-141
Maps BC	1986	1:60,000	BC86079, 21-24
Maps BC	1987	1:70,000	BC87031, 212-214; BC87030, 22-27, 57-60
MacMillan Bloedel	1987 (color)	1:15,000	MB87009, 005-017, 82-106, 180-185; MB87011, 33-60, 120-156; MB87008, 252-260, 275-280
MacMillan Bloedel	1994 (color)	1:19,000	MB94011, 25-47, 110-128, 187-209, 251-268, 293-308
Canadian Forest Products	1993	1:20,000	orthophotos, 5, 6, 9, 10

Table 3.1 List of air photographs for the Tsitika study area.

deposits were all considered potential evidence for landslides.

Locations of mass movement features were initially plotted on two 1:50,000 topographic maps: NTS 92L/7 (Nimpkish) and 92L/8 (Adam River).

Reconnaissance was carried out by helicopter in June 1994. Sites of ongoing mass movement, such as snow avalanche chutes and active rockfalls and talus were differentiated from discrete debris slides, rockfalls and rockfall/avalanches based on physical attributes. Sites delineated as active and which would not be visited in the field were photographed for documentation.

### **3.3 Field work**

A field program was carried out from June to August 1994. This program involved mapping the mass movement sites identified on air photographs, characterizing them in terms of their physical attributes, and collecting tree cores and discs for dating purposes. Where possible, the following data were recorded at each site: landslide type, azimuth direction, initial elevation, aspect, gradient, runout, area, and volume.

Landslides were mapped onto 1:20,000 scale TRIM maps. Where coverage existed, landslides were mapped onto 1:5,000 topographic maps provided by MacMillan Bloedel Limited.

Eight landslides were not accessible in the field. For these landslides data were gathered from existing maps and air photographs, reconnaissance by helicopter, and extrapolated information from the nearest visited sites.

### 3.3.1 Physical features

Landslides were classified according to Varnes' (1978) classification (Table 4.2), based on morphology of the feature. Surficial material and bedrock type were described at each site.

Elevation measurements of the heads and main portions of the landslides were determined from altimeters and from the 1:5,000 maps in the field. Altimeters are considered accurate to 100 m of elevation.

Azimuth and gradient of landslides were determined using a compass and clinometer. Gradients were generalized into upper-slope, mid-slope and lower-slope. The general morphology of the slope was described (concave, convex), as well as the distribution of sediment on the slope.

Areal estimates of landslides were initially calculated using the most detailed maps, typically 1:5,000, and overlaying the mapped landslide with an area matrix grid. Maps of forested areas often lack details given the fact that the photogrammetrist is unable to observe the actual ground. Hip-chain and compass measurements were taken on site to verify the accuracy of the dimensions of the landslides calculated from the maps. The 1:5,000 scale maps were generally found to be accurate in the field. The 1:20,000 scale TRIM maps were also found to be generally accurate, but the details of some small features were absent at that scale.

The area matrix grid may introduce potential errors by smoothing out the data, based on a minimum resolution of 0.25 of a  $\text{cm}^2$ . All field estimates of landslide area were supported by planimeter measurements of the landslide. Areas are considered to be accurate within a few percent of the total area. Accuracy increases with an increase in area.

Landslide volumes were estimated in a number of ways depending on the availability of the data:

- 1) the estimated average depth of a landslide deposit was multiplied by the area of the zone of deposition;
- 2) the estimated average depth of scour, was multiplied by the area of the zone of depletion; or,
- 3) landslides with a large variation in depth of deposition were divided into smaller sections. The depths of smaller units of similar thickness were measured, multiplied by their aerial extent and added together. Depths of deposits were measured at stream or road cuts. These methods are similar to those used by others (Moore and Mathews, 1978, Chatwin and Rollerson, 1984, Evans *et al.*, 1987, 1989, Evans, 1989b)

Volumes inferred for landslides that were not accessible in the field, were based on:

- 1) air photographs and volumes of similar landslides; and/or
- 2) size of fan deposit where a landslide resulted in a debris flow.

In the case where debris from a landslide entered and crossed a stream, the volume of the landslide was determined by:

- 1) subtracting the amount of landslide debris on the slope, from the amount that moved, based on scour depths and extent, and concluding that the difference entered the stream; or,
- 2) in the case where sediment is deposited on the other side of the stream, its volume was noted (thickness x area). A volume equal to the thickness of this deposit, multiplied by the area of the section of stream crossed was calculated to be the minimum amount of sediment removed by the stream. These were summed and compared to data derived in step (1).

Recurring events were determined based on historical air photograph evidence, morphological characteristics where it was apparent that one post dated another, and on dendrochronological evidence (discussed below). Information was not available to differentiate areas or volumes for different events at a landslide site, and therefore combined maximum areas and volumes were determined for the site.

Stream (channel section) and basin orders were determined for the study area based on standard practice, as described by Hewlett (1982), and Coastal Watershed Assessment Procedure (British Columbia Ministry of Forests, 1995c).

### 3.4 Dendrochronology

In addition to air photographs, and archival information, dates of landslides were determined using dendrochronology. Cores were taken from trees on or near the landslides using a Swedish increment corer. Scars, peripheral release growth, and minimum ages were obtained where possible in accordance with methods described by Jozsa (1988) and Schweingruber (1988).

A field count of annual rings was attempted for each core. Samples were placed in plastic straws 0.6 cm in diameter. The ends were folded over and sealed with tape. Each sample was labeled by landslide and core number, and described according to location and tree type. All samples were stored in a cooler for the remainder of the field season.

In the laboratory tree cores were mounted on blocks, sanded with 250 grade sandpaper and mounted onto a moving stage beneath a dissecting microscope. Annual rings were counted from the bark to the pith or scar. Each core was counted three times each by two people. Fieldwork occurred from June - August 1994, and latewood was not yet evident for that year, therefore the first latewood ring next to the bark was considered to represent winter of 1993.

Damaged cores may have resulted in an error of missing rings, however, this error was minimized by additional collaborative samples for the same site.

Skeleton plots were made by plotting the widths of annual growth rings from peripheral cores, showing release growth.

Data were compiled for all landslides and initial dates of the landslides were derived. Tree scars were considered to represent absolute dates, minimum cores offered the youngest possible date, and peripheral cores were used to support the observations from the other two types of dating methods. Because of the different immediate reactions of the peripheral trees, peripheral cores were considered absolute dates, with an error margin of up to 3 years.

Dendrochronological dates were further calibrated against air photographs, based on the evidence for activity in a specific year, as well as anecdotal information for recent landslides. Dates for landslides not visited in the field were limited to air photograph review. This applied to eight landslides, mostly in upper Thursday Creek, and on the upper slopes of Schmidt Creek.

### **3.4.1 Minimum ages**

The removal of timber by a landslide is easily identified on air photographs (Figure 3.1). This typically leads to forest regeneration, beginning in most cases on the landslide deposit at the base of the slope (Smith *et al.*, 1986). The age of the mass movement may be assumed to be no younger than the oldest tree on the landslide deposit.

Red alder (*Alnus rubra*) is considered a pioneer species for coastal Vancouver Island and the entire Queen Charlotte Islands (Parish, 1994). Red alder is succeeded by western hemlock (*Tsuga heterophylla*) and amabilis fir (*Abies amabilis*), and at elevations



Figure 3.1: A landslide in Schmidt Creek as seen from air photograph. Note: New vegetation is beginning to grow at the base of the slide (at arrow). Original scale was 1:20,000, year was 1981.



Figure 3.2: The same landslide seen on an air photograph six years later. Note: Vegetation has now grown much further up the landslide (arrows). The oldest trees are at the base, where they were first established on the site (see Figure 3.1 above). Original scale was 1:15,000, year was 1987.

above 800 m, by mountain hemlock (*Tsuga mertensiana*) as well (Parish, 1994).

Biogeoclimatic zones in the Tsitika study area are primarily elevation driven. Schwab (1995, personal communication) has suggested that for sites in similar biogeoclimatic zones in the Queen Charlotte Islands, red alder typically begin to grow on a landslide by the first available growing season.

Samples for dendrochronology analysis of each landslide were taken in the oldest stand of trees. Selecting the oldest tree(s) for sampling was based to a large extent on experience. In accordance with observed pioneer species succession (above), stands were typically considered oldest near the base of the slide (Figure 3.2). In a case where two or more stands could fit the age criteria, samples were taken from both. Typically three or more samples were taken on each landslide. The upward limit of sample size depended on the complexity of the slide and the integrity of the cores. In a multiple event site, as many as twelve cores were taken. Minimum age values were calculated based on the oldest core(s). The number and types of cores taken at each site are given in Appendix II.

Trees used for minimum age dating were cored from the bark to the pith (Figure 3.3). Rings were identified as couplets of earlywood (light wood) and latewood (denser darkwood), and each ring represents a growth cycle of one year (Schweingruber, 1988). The pith also represents a year. Situations where the pith was not represented in the core were identified, and resulted in additional sampling. In some cases, however, the pith was still not represented in the core and the age was extrapolated based on ring curvature (Figure 3.4). Estimates were conservative, which while potentially introducing an error of missed years, allowed confidence that the core still represented a minimum age.

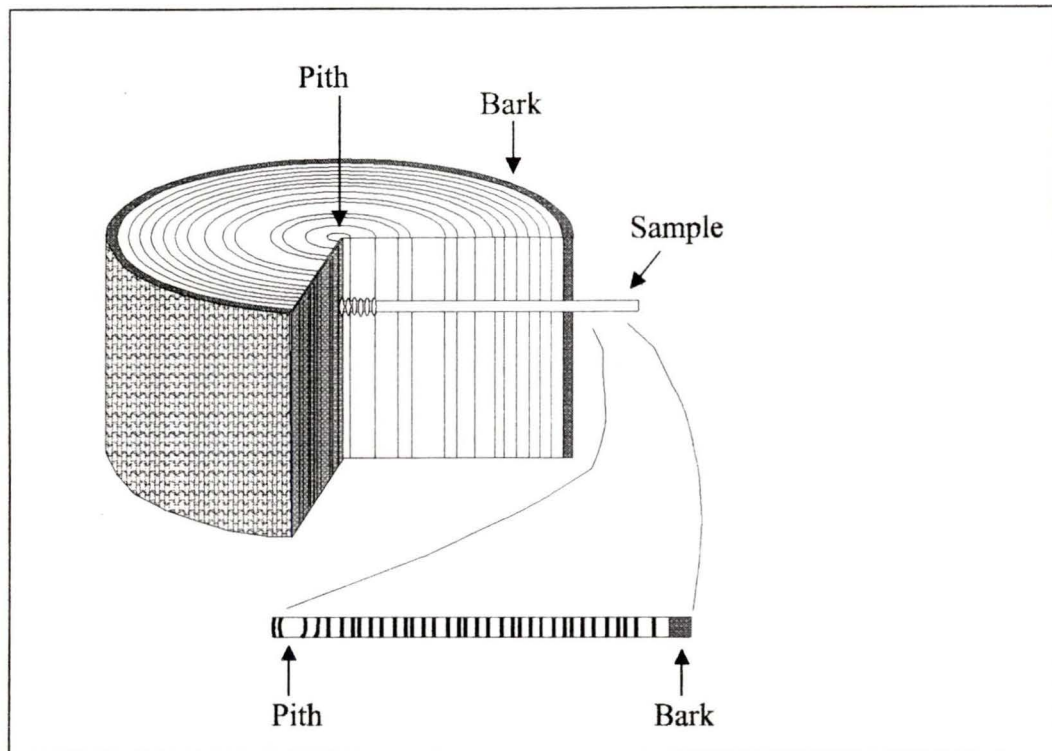

Figure 3.3: In order to correctly identify the age of a tree, the core needs to go from the bark to the pith (adapted from Jozsa, 1988)

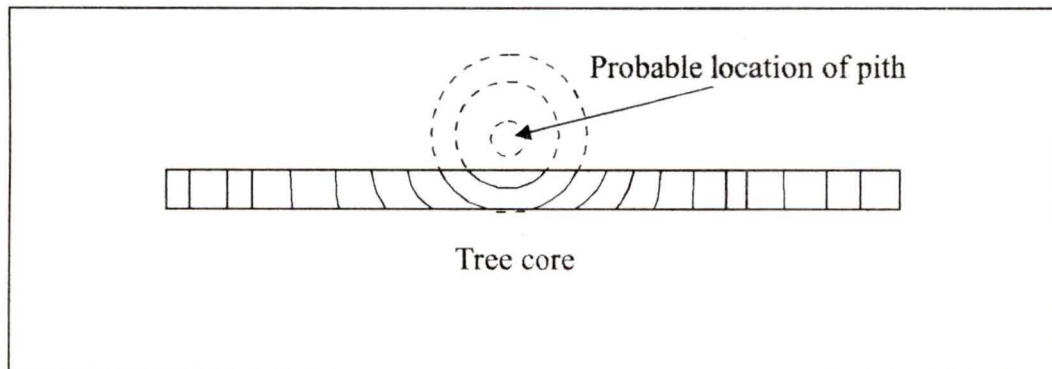

Figure 3.4: Diagram showing how the pith is extrapolated based on tree ring curvature.

Other errors include that the tree core samples may not be from the oldest trees, or that numerous years may have passed before regeneration of vegetation on the slope began.

### **3.4.2 Scars**

Landslide debris often impacts and even lodges in trees on the landslide site and/or around the periphery of the landslide track. Falling trees during a mass movement can impact trees in a similar manner. These physical impacts typically create tree scars. Tree scar dates were obtained at all sites where scars were determined to be related to a slide. Scars related to the slide often had bits of rock imbedded in them, or stones piled at the base of the tree. Scars in trees sampled were always in, or facing, the track of the landslide.

Tree scars were identified by dense compression wood, and their ages obtained by counting the number of years represented by annual ring growth since the scarring event (Figure 3.5) (Schweingruber, 1988). Samples were typically taken as far away from the focal point (of the scar) as possible to avoid missing initial rings following the scarring event (Figure 3.6). Some trees were sampled by removing a wedge or a disc of the tree that contained the scar. This permitted examination of a complete record of the annual ring growth since the time of the event, thereby, reducing potential error.

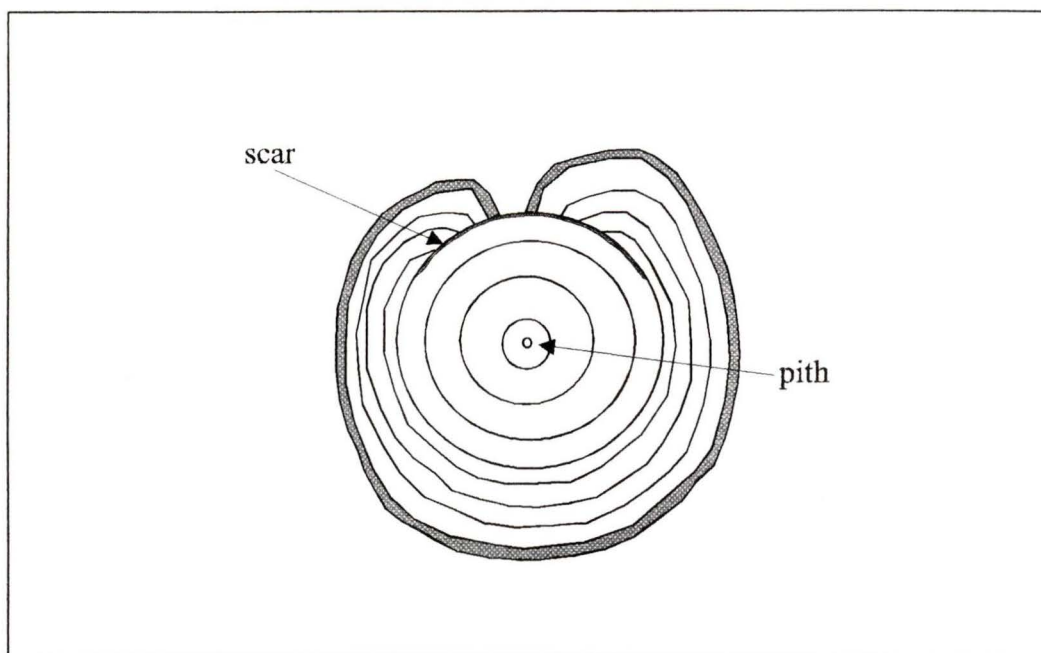

Figure 3.5: The age of an event can be discerned by counting the number of years since scarring (arrow).

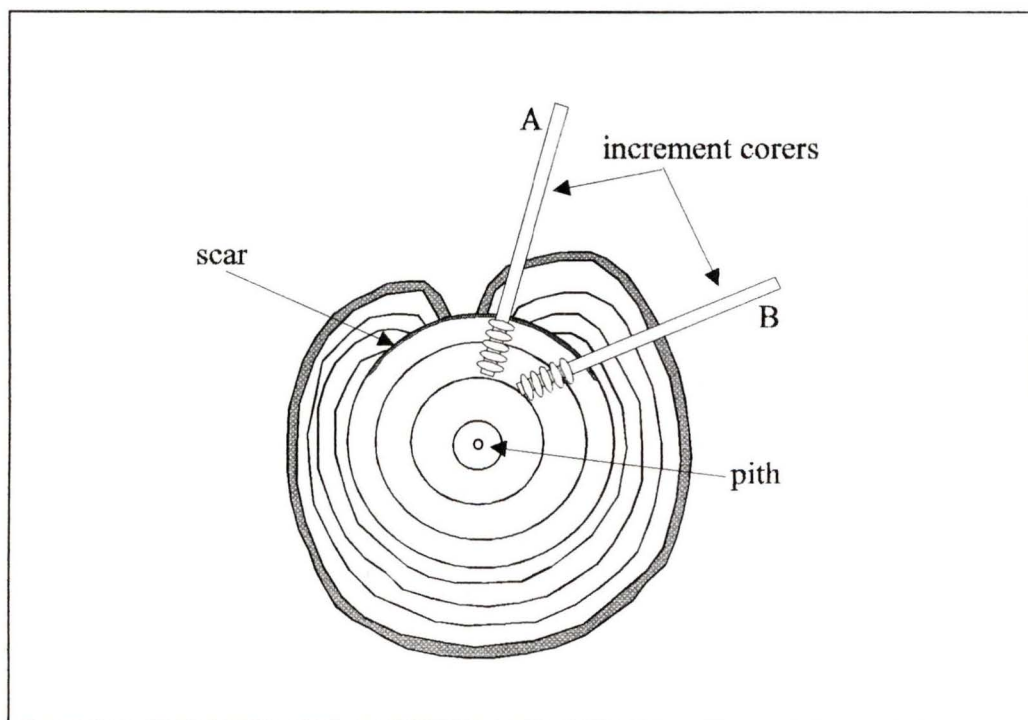

Figure 3.6: A core taken too close to the center of the scar (A) may miss years. Samples were typically taken as far away from the focal point of the scar as possible (B) to obtain accurate readings.

### **3.4.3 Release growth**

Prior to an event, trees growing on the periphery of a landslide competed with surrounding trees for light and nutrients. After a landslide occurs, adjacent trees are removed and competition for resources decreases. This may result in a discernible increase in ring-width (Figure 3.7). The increase may occur immediately, or may follow a delay of one to two years due to the initial shock of a landslide event. An analysis of this release can be used to determine when a significant disturbance occurred (Cook and Kairiukstis, 1990).

In addition to landsliding, road building or logging constitute two types of human activity that can have some effect on the pattern of release growth in trees in the field. For this study, peripheral cores were obtained at locations not likely to be affected by other changes to sources of light or nutrient disturbance.

### **3.5 Precipitation data**

Precipitation data were analyzed from Alert Bay and Sayward stations (Figure 2.1) for 73 years (1914-1916, and 1924-1993), and 18 years (1921-1928, 1974-1981, 1988-1989) of data respectively. Analysis of precipitation data was carried out using methods described by Pugsley (1981), and Hogg and Carr (1985), similar to those used by others (Coligado, 1982, Church and Miles, 1987, Hogan and Schwab, 1991a, and Environment Canada, 1993). The greatest amount of precipitation for each year was recorded for

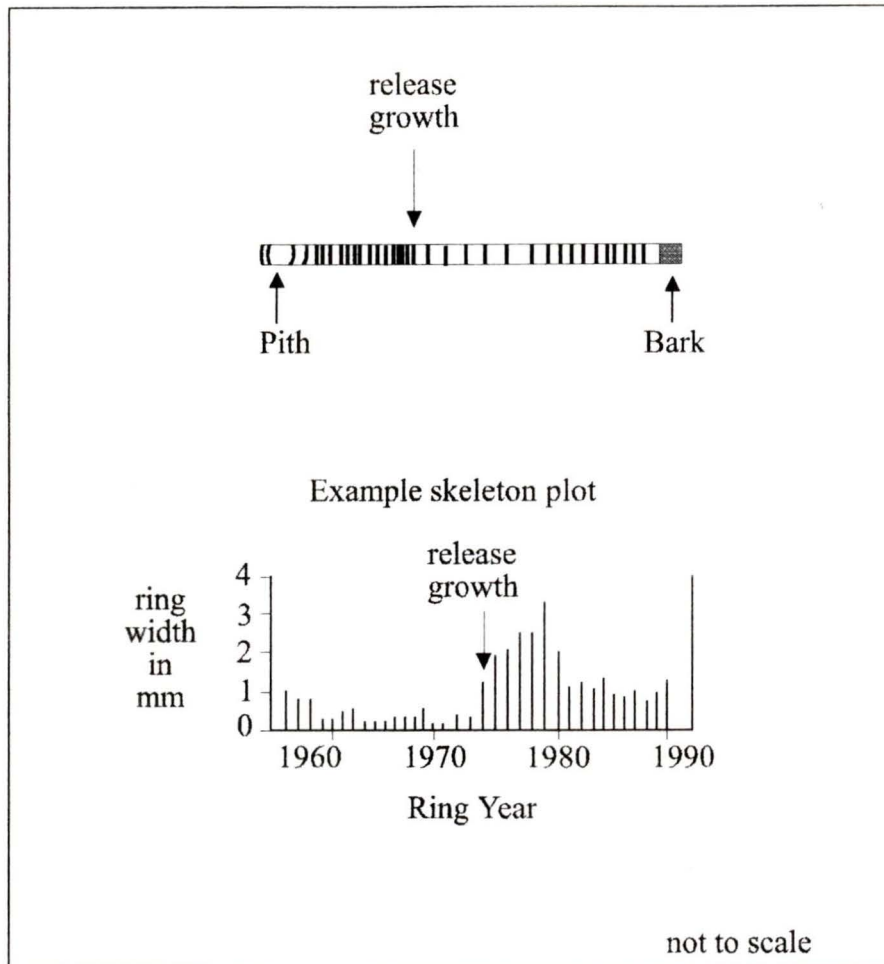

Figure 3.7: Release growth in trees may occur following landslide activity. Release growth is identified by wider annual rings. A skeleton plot is typically made by measuring the rings. This allows the viewer to better see the growth patterns.

1, 2 and 3 day intervals. Return periods of these maximum annual precipitation events were then calculated by M. Miles and Associates, based on the following formula:

$$X=x +K(T)S_x \quad (\text{Hogg and Carr, 1985})$$

where:  $x$  and  $S_x$  are the mean and standard deviation of the sample  
 $X$  is the value equaled or exceeded every  $T$  years  
 $T$  is the return period  
 $K$  is a frequency factor, expressed in terms of return period  $T$  and number of years of record. Standard tables have been derived for the value  $K$ .

Return periods were used to determine whether there was any correlation between the occurrence of large storms and landslides. A list of years was compiled for extreme precipitation events with return intervals less than 1:10 and greater than 1:25 years, less than 1:25 and greater than 1:50 years, and less than 1:50 years. The number of landslides coincident to these years was noted. Landslides coincident to years with return intervals less than 1:25 years were mapped for each year.

### 3.6 Seismic data

Seismic data were acquired from the Pacific Geoscience Centre in Sidney, B.C. All past earthquakes that could have resulted in accelerations of greater than or equal to  $10 \text{ cm/s}^2$  (1% gravity), the minimum threshold that can be felt by humans, in the study area were recorded. Ground movement values and attenuations were determined by the Pacific Geoscience Centre based on Boore *et al.* (1993, 1994).

A literature review of data on the earthquakes was also undertaken. Isoseismal maps were collected where available, and intensities were compared to calculated accelerations in the study area. Earthquakes that could have resulted in intensities greater or equal to modified Mercalli intensities of V in the study area were determined based on the results of these data.

## 4.0 LITERATURE REVIEW

### 4.1 Definitions

Landslide is the general term for the downslope movement of masses of earth, rock and material, and the resulting landforms (RIC, 1996). It is an ambiguous term, which is nevertheless widely used for a wide range of mass movements. A number of authors (Varnes, 1978, Cruden, 1991, and others) have suggested, that while efforts have been made to develop a more precise terminology, no single word or definition is better suited to the task.

The stability of a block of material is described in terms of a ratio between its shear stress (driving forces) and shear strength (resisting forces).

Shear strength ( $s$ ) is described by the Mohr-Coulomb criterion (Ritter, 1978 and Wu, 1996) which states:

$$s = c + \sigma \tan \phi$$

where

$\sigma$  = normal stress on the rupture surface

$c$  = cohesion, and

$\phi$  = angle of internal friction.

Normal ( $\sigma$ ) stress is a resisting force described as the component of stress perpendicular to the rupture surface. Figure 4.1 shows the effective normal stress as:

$$\sigma = W \cos \theta$$

where

$W$  = the weight of a particle on a slope, and

$\theta$  = the slope angle

However, the analysis of slope stability typically concerns the force acting on some plane below ground, along which movement of an overlying block occurs. Normal stress is then described as:

$$\sigma = \gamma H \cos^2 \theta$$

where

$\gamma$  = the unit specific weight, and

$H$  = the vertical distance from the plane to the ground surface.

Shear strength of soils is strongly influenced by drainage conditions. Accounting for pore pressures then, effective normal stress becomes:

$$\sigma = \gamma H \cos^2 \theta - \mu$$

where

$\mu$  = the pore pressure.

Cohesion ( $c$ ) is the portion of shear strength which is independent of effective normal stress. Particle to particle adhesion, internal rock strength and anchoring by roots are all examples of cohesive forces.

Internal friction ( $\phi$ ) is the friction produced when one grain or block slides past another along a well defined planar surface, or when particles are required to move upward and over one another. The angle of internal friction is approximated by the angle at which sliding begins.

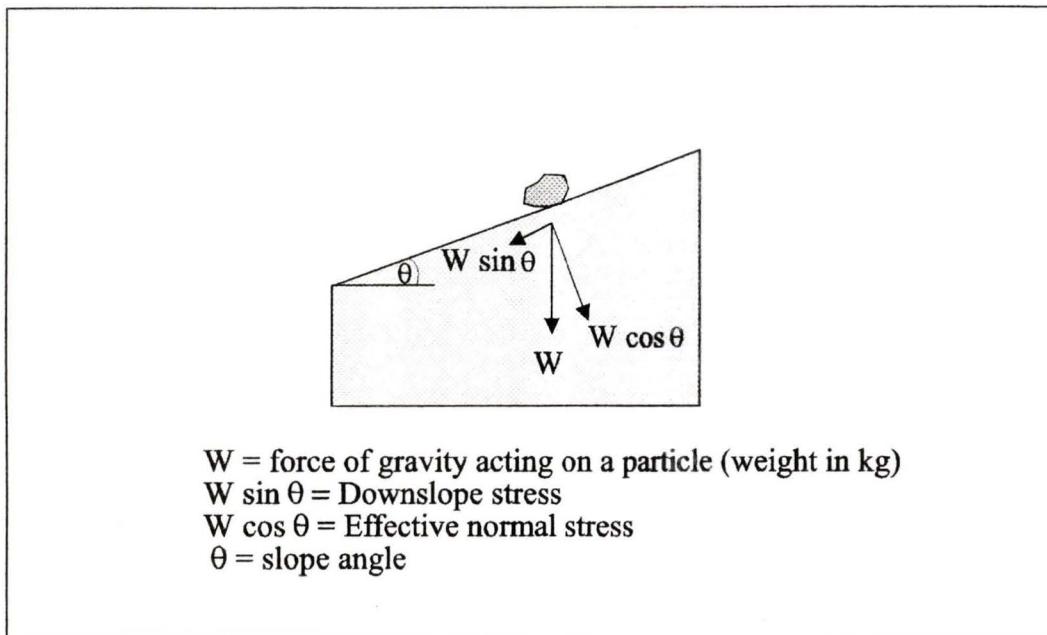

Figure 4.1: A simple model of the forces acting on a particle on a slope. An increase in slope angle translates to an increase in  $\sin \theta$ , and a decrease in  $\cos \theta$  (Ritter, 1978).

Type of Movement			Type of Material		
			Bedrock	Engineering soils	
		coarse		fine	
Falls			rock fall	debris fall	earth fall
Topples			rock topple	debris topple	earth topple
Slides	Rotational	few units many units	rock slump	debris slump	earth slump
	Translational		rock block slide	debris block slide	earth block slide
			rock slide	debris slide	earth slide
Lateral Spreads			rock spread	debris spread	earth spread
Flows			rock flow	debris flow	earth flow
Complex			combination of two or more main types of movement		

Figure 4.2: Varnes (1978) classification of landslides.

The factor of safety ( $F$ ) is defined by Ritter (1978), Swanston and Howes (1994b) and Duncan (1996) as the ratio of shear strength divided by shear stress required for slope equilibrium. It is expressed as:

$$F = \frac{\text{Shear strength}}{\text{Shear stress}} \text{ or } \frac{c + \sigma \tan \phi}{\tau}$$

where

$\tau$  = shear stress required for equilibrium

In theory, if the shear strength exceeds the shear stress, then  $F \geq 1$  and a slope is considered stable. Landslides result from changes which decrease this ratio.

Shear stress is described in Figure 4.1 as  $W \sin \theta$ . This is the driving component of the force and stems from the weight of the particle. Shear stress along a plane below the surface, along which a block of overlying material moves is expressed as:

$$\tau = \gamma H \cos \theta \sin \theta$$

Several factors can modify slope stability by either increasing shear stress, decreasing shear strength, or increasing shear strength (Ritter, 1978, Varnes, 1978, Swanston and Howes, 1994b, and Cruden and Varnes, 1996).

- ◆ Increase shear stress:
  - undercutting (natural and anthropogenic)
  - removal of lateral support (natural and anthropogenic)
  - increased mass (rain, talus, fill)
  - shocks and tilting (earthquakes, blasting)
  - lateral pressure (heaving, freezing)
  - wind stress (loosening, prying)

◆ Decreasing shear strength:

- structure changes (fracturing, downslope dip)
- increase in pore water pressure
- weathering (freeze-thaw, solution, disintegration)
- removal of vegetation

◆ Increasing shear strength: - vegetation growth (anchoring, evapotranspiration)

- engineering effects (anchoring, dewatering slope)

There are numerous classifications of landslides (Varnes, 1978, Lowe, 1979, and Cruden and Varnes, 1996). However, the most widely recognized classification scheme is Varnes' (1978) classification (Figure 4.2). Varnes classification, and modifications of it are used by geologists, engineers and terrain mappers in British Columbia (Howes and Kenk, 1988, Chatwin *et al.*, 1994, RIC, 1996). Three types of landslides identified in this study were debris slides, rockfalls, and rockfall/avalanches.

**Debris slide:** A debris slide refers to a rapid, shallow, unconsolidated mass movement on a steep hillslope. Movement begins when overburden slides along bedrock or another surface of higher strength and lower permeability than the overlying material (RIC, 1996). Debris slides typically begin on open slopes. The term debris slide is synonymous with debris avalanche as used by Howes (1981a), and Swanston and Howes (1994b).

Debris slides are easily identified by a linear, wedge shaped track, expanding toward the base of the slope (Figure 4.3). Older debris slides are identified by similar tracks, usually covered by vegetation of different species or maturity (height) than the



Figure 4.3: The wedge shaped track of a landslide in the study area.

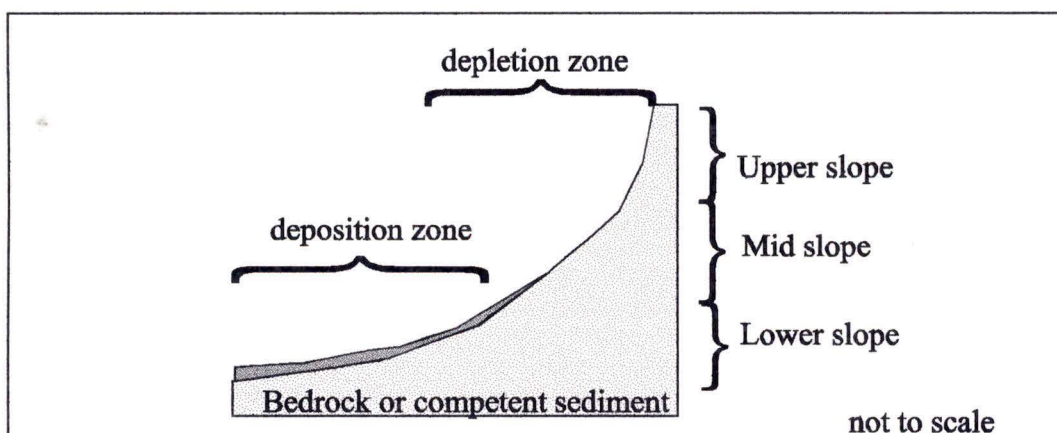

Figure 4.4: A typical profile of a debris slide.

surrounding slope. Debris slides are common on steep, mid-upper slopes of a valley wall, and can extend to a stream channel. They are typically concave in profile (Figure 4.4). The upper-slope of the debris slide is typically described as the portion with the steepest gradient, and which is represented by the zone of depletion. The lower-slope is typically described as the portion of the slope with the flattest gradient, represented by the zone of deposition. A debris pile is a common feature within the deposition zone. The mid-slope is usually of an intermediate grade and may represent a portion of slope referred to as the transportation zone, along which scour and deposition are approximately equal. The terms lower-slope, mid-slope, and upper-slope are descriptive, the absolute slope angles and length of that portion of slope are highly variable and listed in Appendix I.

**Rockfall:** A rockfall refers to relatively free falling, leaping and bounding downslope movement of a detached portion of bedrock from a cliff or other very steep slope (RIC, 1996).

Rockfalls are identified in the study by the presence of a detachment face on a steep cliff, and a track where the rock has fallen, broken up and is deposited (Figure 4.5). Active rockfalls may be identified by the presence of talus cones at the base of cliffs.

**Rockfall/avalanche:** A rockfall/avalanche refers to the rapid downslope movement of a large mass of rock fragments derived from bedrock. The rock fragments take on the character of a (dry) flow, becoming highly mobile and able to travel a great distance over a shallow gradient. The term rockfall/avalanche is synonymous with Hsu's (1975) and Carpenter and Easterbrook's (1993) use of *Sturzstrom*, Cary *et al.*'s (1992) use of mega-



Figure 4.5: A typical rockfall, showing the detachment face and deposition path.

landslide, VanDine and Evans' (1992) use of rock-fall/avalanche and RIC's (1996) use of rock avalanche.

Rockfall/avalanches are identified in the study area by their relatively large size (more than 10 times larger than discrete rockfalls or debris slides in the study), steep bedrock cliffs that represent the detachment face, and a long runout zone over a relatively flat gradient.

In addition to those described above, other types of mass movements were observed but were not recorded in detail in this study. In particular, channelized debris flows and snow avalanches were prominent in the study area. They are defined below.

**Channelized debris flow:** A channelized debris flow is defined as a rapid flow or slurry of saturated debris, down a steep, confined, pre-existing channel. The term was coined by Evans (1982) and is synonymous with debris torrent (VanDine, 1985, Swanston and Howes, 1994b, RIC, 1996) and debris flow (Varnes, 1978). Debris slides which transport sediment directly into a channel are often the cause of channelized debris flows. Channelized debris flows in the Tsitika were the subject of a study by Sterling (1996).

**Snow avalanche:** A snow avalanche refers to a large mass of snow and ice moving rapidly downslope (RIC, 1996). Snow avalanches may be accompanied by organic and inorganic debris.

Snow avalanches may be distinguished from other landslide types by linear to tapering tracks, initiating from high elevations with large catchements. Snow avalanche tracks are often vegetated with low pioneer tree species or shrubs.

## 4.2 Previous Work

Landslides are studied all over the world where steep slopes result in the potential hazard of mass movements. They are of particular concern in areas of high precipitation, seismic activity, or which have high populations. This includes the Canadian Cordillera (Cruden *et al.*, 1989, Evans and Gardner, 1989, Clague, 1991, Evans, 1992 and VanDine, 1992 for example). In the United States, landslides are studied in Washington (Cary *et al.*, 1992, Jacoby *et al.*, 1990, 1992, Carpenter and Easterbrook, 1993, Wuethrich, 1994), Oregon (Coats and Collins, 1984, Schroeder and Brown, 1984, Wuethrich, 1994), California, (Slosson and Larson, 1995), Utah, (Alard, 1980), Wyoming, (Jensen, 1983), and many other states. Landslides are also a problem in Japan (Kashiwaya *et al.*, 1989), Italy (Strunk, 1989), Brazil (Guidicini and Iwasa, 1977), New Zealand (Whitehouse and Griffiths, 1983), in addition to many other countries. A world landslide inventory has been compiled by the United States Geological Survey (Brown *et al.*, 1992a, 1992b).

### 4.2.1 Queen Charlotte Islands

Historically, investigations of landslides in coastal British Columbia have focussed to a large extent on the Queen Charlotte Islands. Severe rainstorms in the late 1970's caused numerous landslides on the Queen Charlottes (Chatwin and Smith, 1992). In response, several government agencies began investigating landslides and their implications. The main thrust of this work occurred under the Fish/Forestry Interaction Program (FFIP), initiated in 1981 (Chatwin and Smith, 1992). The overall objectives of the FFIP were (from Chatwin *et al.*, 1994):

- ◇ To study the extent and severity of mass wasting and to assess its impacts on fish habitat and forest sites.
- ◇ To investigate the feasibility of rehabilitating stream and forest sites damaged by landslides.
- ◇ To assess alternative silvicultural treatments for maintaining and improving slope stability.
- ◇ To investigate the feasibility and success of using alternative logging methods, including skylines and helicopters, and by planning to reduce logging related failures.

Results of research and investigations are published in the Land Management Report series by the British Columbia Ministry of Forests, as well as papers presented in technical journals and at symposiums and conferences. Some of these results are summarized below.

Initial work on the 1978 storm, which resulted in numerous landslides in the Queen Charlottes was done by Schwab (1983), and later by Hogan and Schwab (1990, 1991a, 1991b).

Schwab (1983) initially examined 264 mass movements following the storm, and described them in terms of type, distribution, area disturbed, and whether or not they occurred on forested or clear-cut terrain. Schwab (1983) found that slightly less than half of all landslides occurred on clear-cut terrain. The return period for the 1978 storm was estimated to be about 5-10 years. Additional work in 1990 (Hogan and Schwab, 1990), described in detail the precipitation and runoff characteristics of the Queen Charlottes, and allowed a more comprehensive regional study (Hogan and Schwab, 1991a). Hogan and

Schwab (1991a) examined 712 hillslope failures in five areas of the Queen Charlottes. Failures were based on reports for the years 1964-1984, and were analyzed in reference to meteorological conditions published in 1990. The majority of landslides (>80%) were related to two years; 1978 and 1984, with 1978 being the most important of the two (in terms of numbers of landslides). More recently Hogan and Schwab have looked at landslides affecting more than 1.0 ha that occurred regionally over the last 150 years. Landslides were dated based on dendrochronology, with ages related to severe precipitation events, where possible. Preliminary results in some areas show that as much as 85% of landslide volumes were moved during only four storms since 1891 (Hogan and Schwab, 1991b). In two locations (Graham Island and Prince Rupert area) a single storm (1917) may be responsible for more than 30% of transported sediment due to landsliding. The impact of some of these landslides on salmon spawning grounds and fish bearing streams was described by Hogan and Schwab (1991b).

Other early studies in the Queen Charlotte Islands include a regional inventory of landslides (Chatwin and Rollerson, 1984). This study examined post logging slides in detail, including visiting 114 sites, and described them in terms of type size and area disturbed, and slope angle, followed by statistical analysis. They concluded that the majority of landslides in the study area were debris slides that occurred primarily in clearcuts. Slope angle, soil moisture, or terrain type did not appear to affect the area of landslides, and landslides on lower angled slopes correlated well with saturated soil types. Natural landslides (pre-logging) were not examined in detail.

Krag *et al.* (1986) attempted to determine reasons for the occurrence of landslides on logged terrain in the Queen Charlottes. They found that yarding disturbance could not be reliably separated from natural factors such as storms and seismic activity.

Smith *et al.* (1986) looked at revegetation patterns and forest productivity on 49 landslides and compared those with revegetation patterns on logged sites. Landslide sites produced significantly less wood volume (70% less on average) than logged sites of the same age.

Regional air photograph inventories of landslides in the Queen Charlottes were undertaken by Rood (1984) and later Gimbarzevsky (1988). Gimbarzevsky identified over 8,000 large slope failures, of various types, from 1:50,000 scale air photographs.

One of the cumulative products of the work to date is the Guide for the Management of Landslide Prone Terrain in the Pacific Northwest (Chatwin *et al.*, 1994). Clearly there are significant benefits to studying landslides in this region. Further work needs to be done, however, on natural landslides, their potential causes and expected frequencies.

#### **4.2.2 Vancouver Island**

Regional reviews of landslides on Vancouver Island include an inventory of 34 large (>1,000,000 m<sup>3</sup>) and 40 smaller landslides by VanDine and Evans (1992). This inventory was carried out on air photographs, in part to assess the potential landslide response to earthquakes on the island. The majority of landslides were estimated as being older than 100 years. Twenty six percent were estimated to have occurred within the last

50 years, and six were inferred to be associated with the 1946, magnitude 7.3 earthquake on Vancouver Island.

Howes (1981a, 1981b, 1983) compiled a regional summary of slope stability on northern Vancouver Island that examined the general characteristics of mass movements in a 15,655 km<sup>2</sup> area. Surficial material, bedrock, and their textural and structural features, in addition to landforms and topography were discussed. The influence of these characteristics on land use activity and on mass movement processes was also discussed. Products included 1:50,000 and 1:250,000 terrain maps. In his final chapter, Howes (1981a) stressed that the relationship between forest harvesting on steep slopes, and its effect on sediment production was not fully understood. He stated that the lack of current understanding rests in the fact that slope processes have been occurring for the past 10,000 years, yet the environment has apparently maintained itself during that period. He recommended that natural watersheds on the island be set aside in order to study slope processes, and specifically their effect on the fluvial system. Howes also suggested the importance of determining the significance of earthquakes as a triggering mechanism in the mass movement process.

Some work on seismic triggers has been done by Mathews (1979) who related numerous landslides on Vancouver Island to the 1946 earthquake. Mathews concluded that landslides may occur on the island at modified Mercalli intensities as low as VI. His analysis was based on fresh landslide scars, evident on a review of air photographs taken between 1946 and 1957. One prominent landslide on Mount Colonel Foster, has been further corroborated by Evans (1982, 1989a) to be related to the 1946 earthquake.

### 4.2.3 Tsitika watershed

The Tsitika watershed is important as one of the few remaining natural watersheds on Vancouver Island (less than 10% logging at the time of field work). It is in addition an area of interest to various public organizations and environmental groups. The Tsitika River empties into Robson Bight, famous for its orca rubbing beaches. The river is important not only as a high value fish stream, but for the estuary as well. Both environments could be adversely affected by the addition of large quantities of sediment to the bedload. Information on the natural background sediment inputs to the Tsitika River and Schmidt Creek are critical to develop sound management guidelines for the surrounding lands.

As early as 1975, land use in this basin was being closely examined (North Island Study Group, 1975) for the potential impacts forest harvesting in the watershed would have on slope stability, and sediment generation. The Tsitika watershed continued to be a concern for environmental groups (Western Canada Wilderness Committee, 1990) who felt that too much logging had already taking place. It was also a concern for industry and government (British Columbia Ministry of Forests, 1990, Tsitika Follow Up Committee, 1991, and Forgis Resource Consultants, 1991) who addressed concerns on the impact of logging on orcas, and on the effectiveness of government regulations. The assessment of the natural contribution of sediment, and the impact which landslides have had in such a watershed, is of significant value.

Maynard (1991) undertook an inventory of all sources of sediment into the Tsitika River, other than those directly associated with channel bank erosion of the main stem.

Maynard produced 1:20,000 maps, showing terrain types along road sections, and the location of sediment sources. He concluded that most sources of eroding sediment in the watershed are associated with logging roads, but that most of these sources involve low volumes of material, not directly connected to the Tsitika River. Maynard further concluded that most direct sedimentation into the Tsitika River and its tributaries are the result of natural landsliding.

Sterling (1996) recently undertook a project that examined the impact of geology on the magnitude and frequency of channelized debris flows in the Tsitika watershed. Looking only at recent (<30 years) events, Sterling concluded that debris torrents are more likely to occur over Karmutsen Volcanics than other bedrock (Sterling, personal communication).

Fannin (1991) and Fannin *et al.* (1992) closely examined a single, large channelized debris flow in the Tsitika River basin. This debris flow is 2.5 km long from source to fan, and ranges in gradient from about 44 - 14°. Grain size analysis suggested predominantly coarse material from cobbles and boulders to sand. As part of a long term sediment monitoring program, a video camera was set up to monitor activity on the fan. Fannin (1991) and Fannin *et al.* (1992) predicted a maximum channel debris yield at this site as high as 27 m<sup>3</sup>/m. The source area for this channelized debris flow is shown as TR07 on Figure 5.1 and in appendix II.

In addition to the studies mentioned above, VanDine and Evans (1992) observed two large rockfall/avalanches in the Tsitika watershed, as part of a regional inventory of large landslides on Vancouver Island. One of the objectives of the study was to identify

landslides that may have been associated with the 1946 Vancouver Island earthquake (magnitude 7.3). Neither of the two rockfall/avalanches identified in the Tsitika were so correlated, but this may have simply been due to a lack of sufficient evidence. The authors were restricted largely to high level airphotos (VanDine and Evans, 1992). They did, however, suggest that the 1946 earthquake had the greatest effect in terms of stability, of any seismic event in the past 50 years. In addition, VanDine and Evans (1992) noted that the majority of their landslides occurred (65%) in Karmutsen Volcanics.

### **4.3 Trigger Mechanisms**

Landslides have been defined previously in this chapter (4.1) as occurring when shear strength is overcome by shear stress. Several factors that modify slope stability are also described. These factors may serve as trigger mechanisms, causing a critical change in the failure value (F), thus resulting in a landslide.

Appropriately, trigger mechanisms are given considerable attention in the literature. Many authors are concerned about the potential effects that forestry and road construction may have on stability (Chatwin and Rollerson, 1984, Sauder *et al.*, 1987, Howes and Sondheim, 1988, Rollerson, 1992, British Columbia Ministry of Forests, 1995a, 1995b for example). Less commonly recognized are trigger events such as the melting of permafrost terrain (Savigny *et al.*, 1992), the catastrophic breaching of moraines or landslide dammed lakes (Clague *et al.*, 1985, Evans, 1986) and landslides that are initiated by glaciers (Mokievsky-Zubock, 1977). In the Pacific Northwest, and

elsewhere, the two most commonly cited factors which tend to slope instability are precipitation (Church and Miles, 1987, Kashiwaya *et al.*, 1989, Hogan and Schwab, 1991a, Chatwin and Smith, 1992, Chatterton, 1994, Larson, 1995, Slosson and Larson, 1995, Septer and Schwab, 1995, Weiczorek, 1996), and seismic activity (Skermer, 1973, Keefer, 1984, 1989, Evans, 1989a, 1989b, Jacoby *et al.*, 1990, 1992, Alexander and Formichi, 1993, Weichert *et al.*, 1994, Weiczorek, 1996).

Meteorological antecedents have been considered by a number of authors. Skermer (1985) wrote that climate, specifically precipitation, could have sudden devastating effects on regional geomorphic processes, and suggested naming these climatic shocks "climequakes". Evans and Lister (1984) and Evans and Clague (1988, 1989) described numerous slides in the Cordillera that occurred as a direct result of severe rainstorms in 1983 and 1988, respectively. The 1983 storm also triggered numerous slides in nearby Washington state (Buchanan and Savigny, 1990). VanDine (1985) suggests that the most common trigger mechanism to channelized debris flows in the Cordillera is extreme water discharge, which may result from intense rainfall. As noted above, studies by Hogan and Schwab (1990, 1991a, 1991b) have attributed landslides to extreme precipitation events. Church and Miles (1987), however, observed that the prediction of specific weather conditions that may result in mass movements is very difficult. Recent attempts at prediction have been attempted by Slosson and Larson (1995) in California which experiences similar conditions to coastal British Columbia, and by Chatterton (1994), for British Columbia. Both analyses are based on observed frequencies of

landslides and precipitation values. Additional data relating precipitation and landslide frequencies may better refine our ability to predict landslides in British Columbia.

Seismic activity is also a clear contributor to the occurrence of landslides.

Mathews (1979) suggested that the 1946, magnitude 7.3 earthquake on Vancouver Island, was responsible for numerous landslides across the island (described previously), however, he recently suggested a degree of uncertainty concerning some of the landslides that he initially attributed to the earthquake (VanDine, 1995 personal communication). The study did not consider other potential trigger mechanisms, and dating of landslides. In addition, he was limited to incomplete air photograph coverage of Vancouver Island, immediately following the 1946 event. Results are uncertain as to whether or not the landslides were in fact all due to the earthquake or if some were related to a later storm event. The study has been supported to some extent by work done by VanDine and Evans (1992), and Evans (1982, 1989a).

Minimum earthquake intensity values at which landslides occur have been determined by Mathews (1979) as modified Mercalli intensity VI, and more recently by Keefer (1984) as V (albeit rarely). While it is evident that both precipitation and seismic activity have triggered landslides in British Columbia, it is not presently clear what the relative contributions to mass movements in a given area are by either mechanism.

#### 4.4 Dendrochronology

Dendrochronology as a dating technique has been developed extensively since the early 1900's. It is based on the assumption that the historical growth of trees can be recognized by the counting of annual rings. In addition, trees of different but overlapping ages may be correlated with one another based on similarities in the patterns of ringwidths. This overlapping of trees is known as crossdating and allows for the development of a chronology that exceeds the life of any individual tree (Cook and Kairiukstis, 1990, and references within).

Recently, dendrochronology has been used to address geomorphologic problems (Schroder, 1980, 1985, Hupp, 1991), varying from studies dating glacial moraines (Luckmann, 1988, Smith and Laroque, 1996) and glacier-dammed lakes (Clague *et al.*, 1982), to landslide dating (Terasmae, 1975, Moore and Mathews, 1978, Schroder, 1978, Parker and Jozsa, 1981, Jozsa, 1981, Clague and Souther, 1982, Begin and Filion, 1985, 1988, Hupp *et al.*, 1987, Evans, 1989a, Jacoby *et al.*, 1989, 1992, and Sterling, 1996). Typically these authors use minimum age dates or scars to date morphological features.

## 5.0 RESULTS

The Tsitika study area comprises two drainage basins; the Tsitika River and Schmidt Creek. Mass movement is a significant process in both drainages, resulting in a modification of the landscape. This chapter describes 43 landslide events at 31 sites. Schmidt Creek is referred to as a subdrainage for the purposes of the results and discussion, due to its size and similarity to the other subdrainages in the Tsitika watershed.

### 5.1 Movement Type and Distribution

Landslides were documented in detail at 31 sites in the study area, and fall into three categories; debris slides, rockfalls and rockfall/avalanches. The types of landslides are defined in detail in section 4.1.

Landslides frequently result in the loss of vegetation at a site which significantly reduces soil strength and the removal of water from the soil. In addition water is often diverted onto a landslide by its post-event morphology. For these reasons, landslides are likely to reoccur at a site where sufficient material remains; a situation common to debris slides. Evidence was obtained through air photographs and dendrochronology for 43 events occurring at the 31 sites. Ten events occurred over six debris slide sites. A rockfall/avalanche also failed twice. In order that the repeat events did not inadvertently skew the results and de-emphasize the physical factors that contribute to slope instability, and because of the lack of information available on older events, results focus primarily on

the 31 landslide sites. Unless otherwise specified, references to landslides, debris slides, rockfalls, or rockfall/avalanches in both the results and discussion are to the sites, not to specific events at the sites. Multiple events and their implications to the results are described in sections 5.10 and 6.5.

Debris slides are the most common landslide type, accounting for 26 (84%) of the total number of sites. Rockfalls account for another three (10%), and rockfall/avalanches for two (6%) of the landslide sites. The distribution of landslides across the study area varies considerably (Figure 5.1), and this variation is described below. The number of landslides per subdrainage is given in Table 5.1, along with the relative areas (in % of the whole) of each subdrainage.

There are a disproportionate frequency (by area) of landslides in Catherine Creek, Thursday Creek, and Schmidt Creek (17 landslides or 54%). Tsitika River has eight (26%) of the landslides. In contrast, Claude Elliott Creek, Tsitika Lake, Mount Elliott and Russell Creek together account for only six (19%) of the landslides. These are no more than the number of landslides in Thursday Creek. Of these landslides, half are bedrock failures, as opposed to failures in surficial sediment. Two are rockfall/avalanches and one is a rockfall. Only three (12%) debris slides are in this area.

Claude Elliott Creek, Mount Elliott, Russell Creek, Thursday Creek, and Catherine Creek have large areas where active mass movements such as active rockfall and snow avalanching are common. Figure 5.2 shows the generalized concentrations of active mass movements (return periods approach or exceed annual) in the study area. Discrete debris

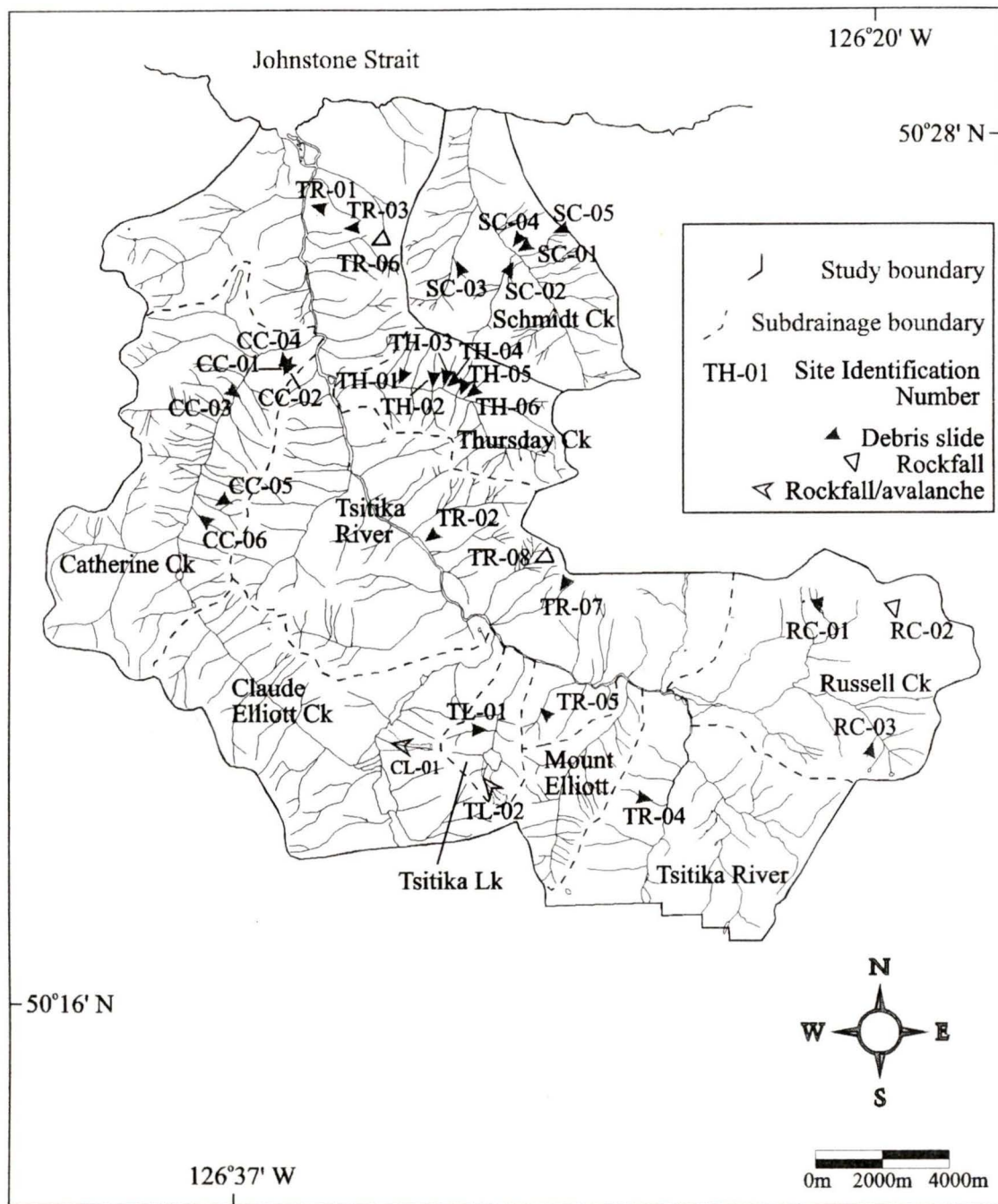

Figure 5.1: Landslide sites and identification numbers in the study area.

Subdrainage	% of study area	Debris slide (n/%)	Rockfall (n/%)	Rockfall/avalanche (n/%)	Total landslides (n/%)
Tsitika River	43	6/23	2/67	0	8/26
Schmidt Creek	9	5/19	0	0	5/16
Thursday Creek	5	6/23	0	0	6/19
Catherine Creek	14	6/23	0	0	6/19
Claude Elliott Creek	13	0	0	1/50	1/3
Tsitika Lake	2	1/4	0	1/50	2/6
Mount Elliott	3	0	0	0	0
Russell Creek	11	2/8	1/33	0	3/10
Total	100	26/100	3/100	2/100	31/100

Table 5.1: Distribution of landslides by various subdrainages of the Tsitika study area. Percent signs indicate percent of the total number, n indicates number.

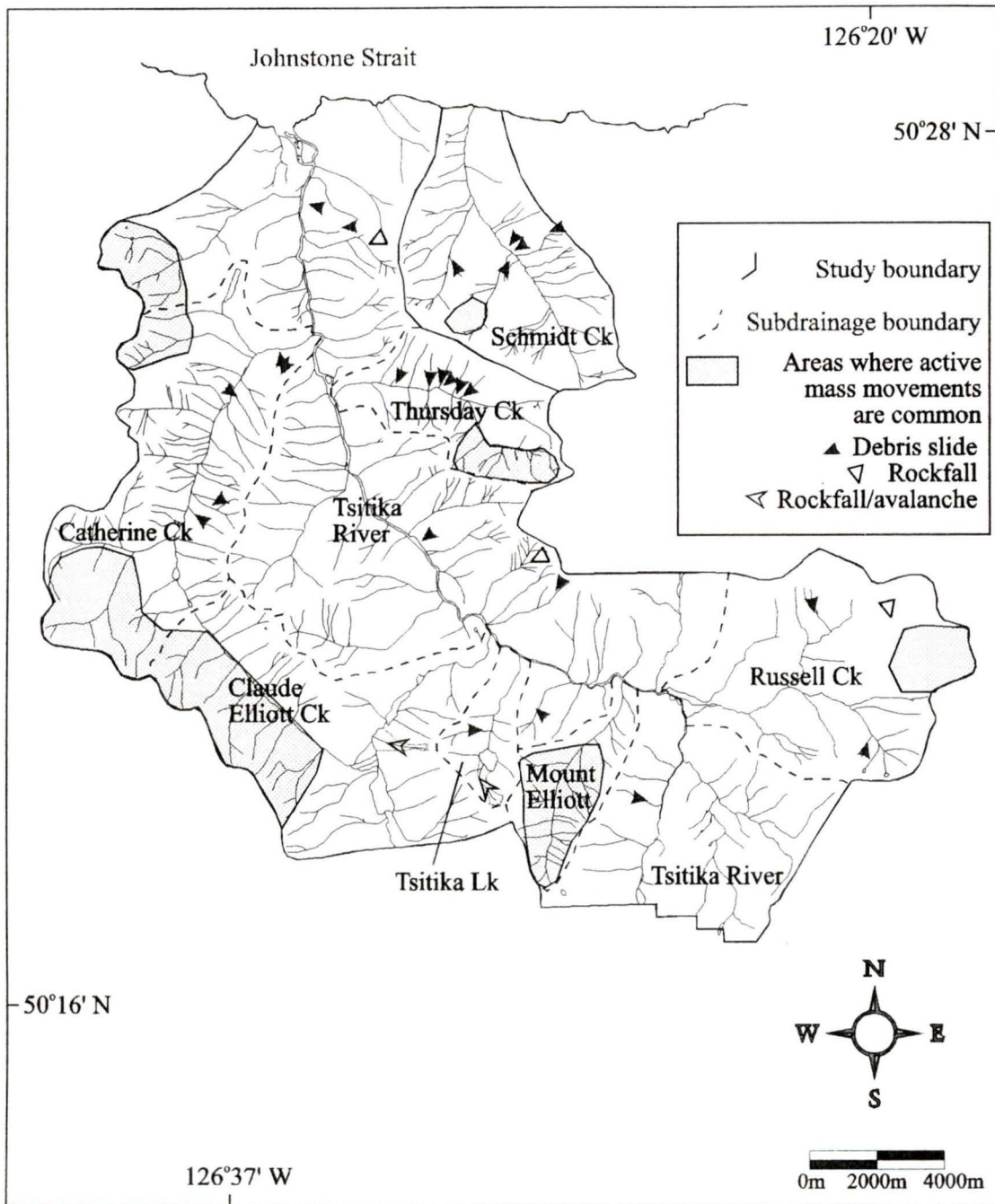

Figure 5.2: The generalized concentration of active mass movements (snow avalanching, and active rockfall) in the study area in relation to discrete events.

slides, rockfalls, and rockfall avalanches are notably lacking in these areas.

Figure 5.3 shows the distribution of landslides relative to the bedrock geology. Claude Elliott Creek, Tsitika Lake, Mount Elliott, Russell Creek subdrainages, and about half of the Tsitika River subdrainage, are underlain by Island Intrusives (the Vernon Batholith). The remainder is underlain by Karmutsen Volcanics. Seventy seven percent (20) of debris slides, and two of three rockfalls occur in areas underlain by Karmutsen Volcanics. Both rockfall/avalanches occurred in areas underlain by the Island Intrusives.

Figure 5.4 shows the distribution of landslides relative to the surficial geology. Fifteen (58%) debris slides occur in morainal deposits while the remainder occur in colluvium. In contrast, all three rockfalls and both rockfall/avalanches occur in bedrock overlain by shallow colluvial soils.

Landslides appear concentrated at three locations in the study area; Schmidt Creek, Thursday Creek, and Catherine Creek. In all three cases, landslides occur in morainal deposits, underlain by Karmutsen Volcanics.

## **5.2 Azimuth**

Azimuth directions of landslides in the Tsitika study area are shown in Figure 5.3. A summary rose diagram of azimuth direction is given in Figure 5.5 comparing landslides over the two different bedrock units. Landslides in the Karmutsen Volcanics show a strong southwesterly orientation and therefore a southwesterly aspect on slopes in the study area. In contrast, landslides over the the Island Intrusives, are distributed

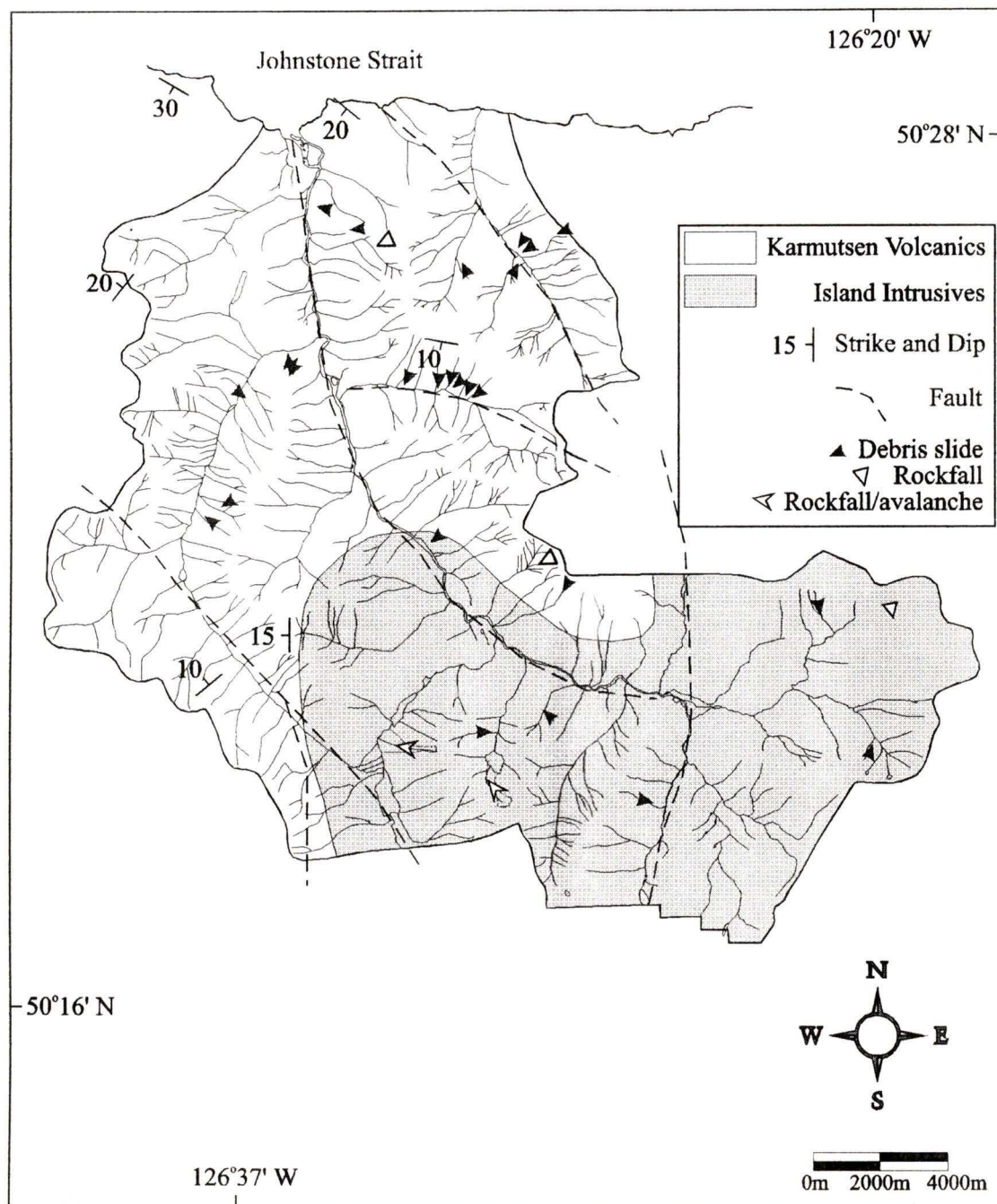

Figure 5.3: The distribution of landslides relative to bedrock geology.

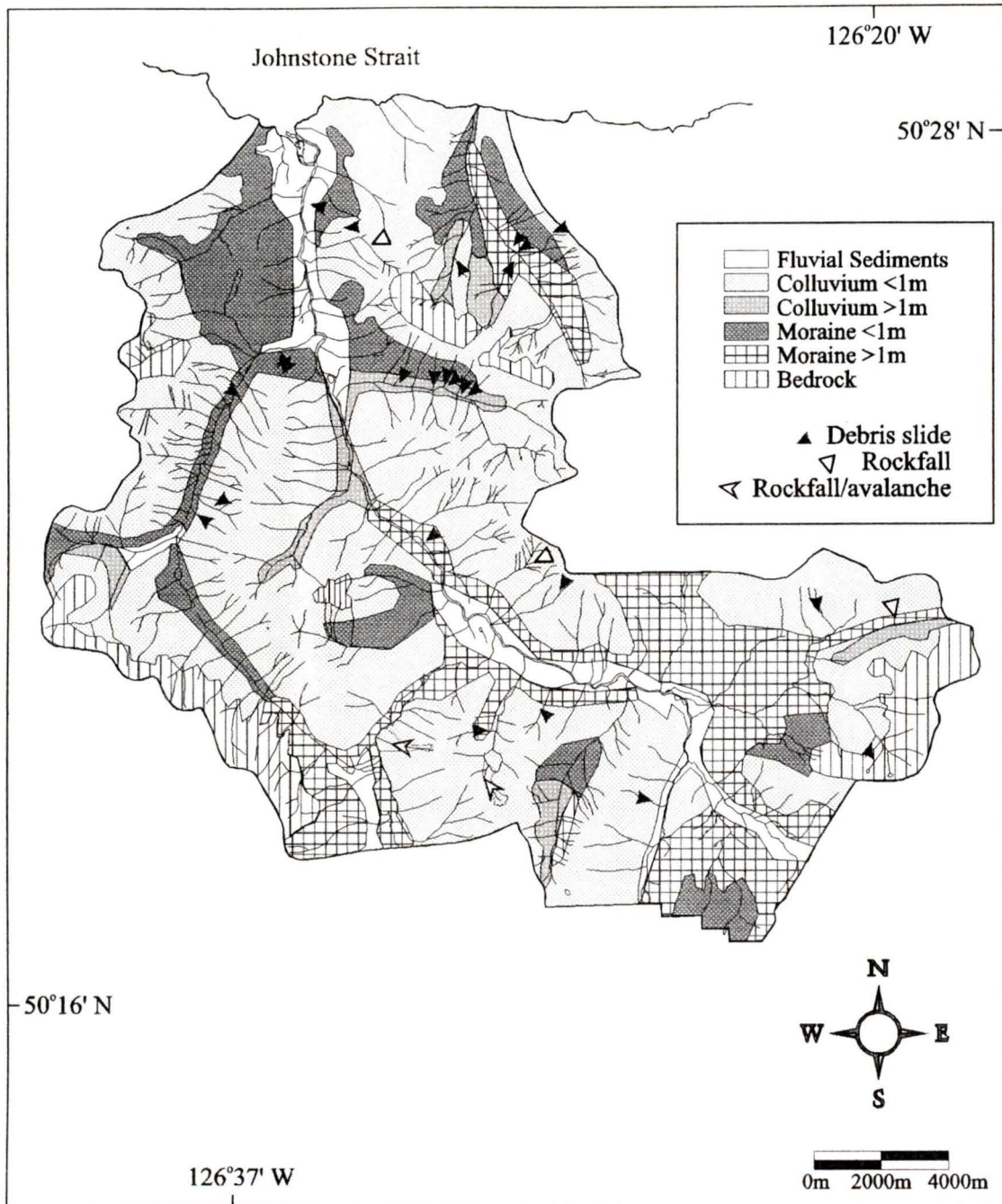

Figure 5.4: The distribution of landslides relative to surficial geology.

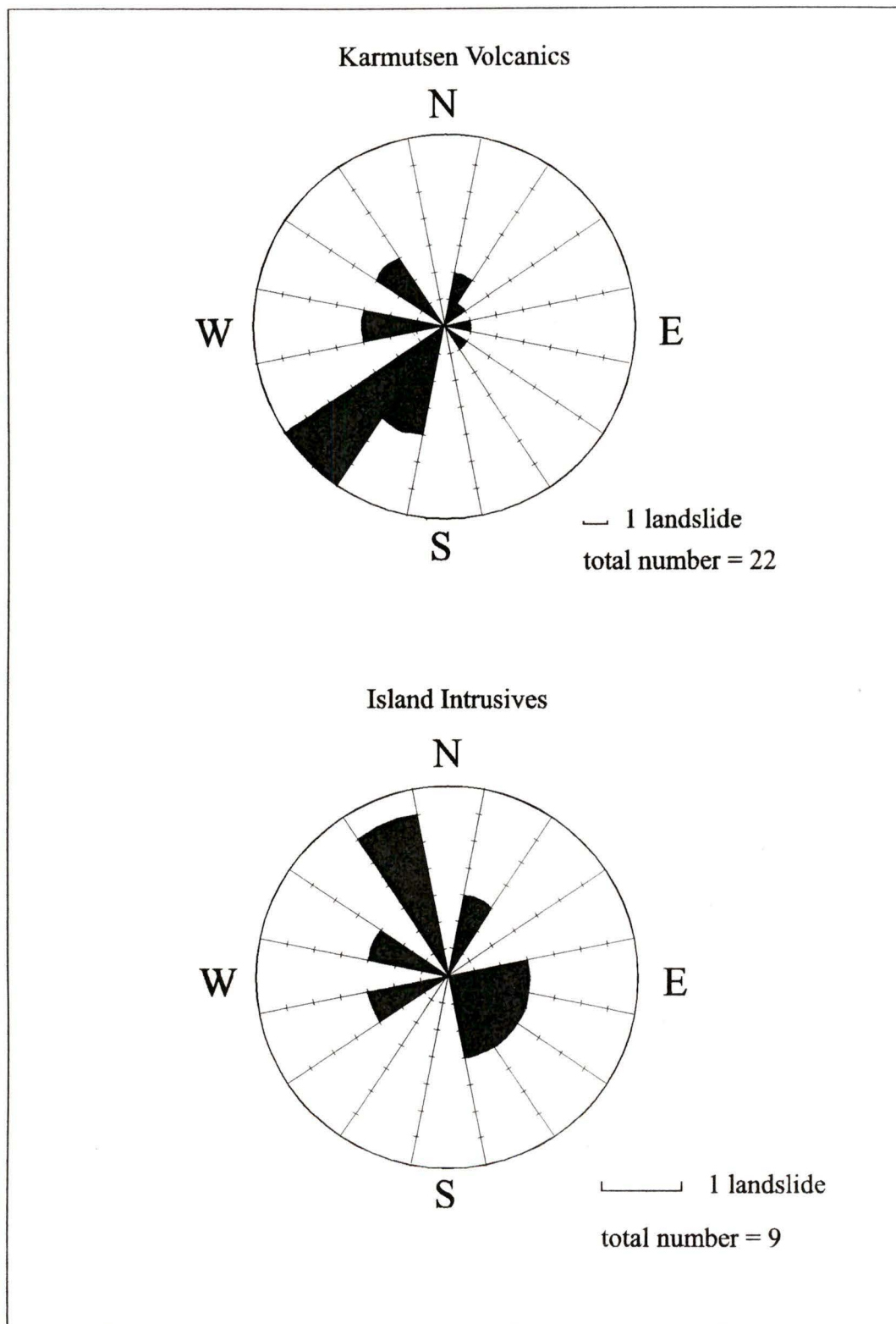

Figure 5.5: Azimuth direction of landslides in the study area compared to geology.

more evenly over 360°. Azimuth directions of landslides in the Karmutsen Volcanics, are largely coincident to dip.

### 5.3 Initial Elevation

The elevation of landslide initiation in the study area varies considerably, ranging from 150 - 1,380 m. The overall mean initiation elevation is 793 m with variations by landslide type. The initial elevations of rockfalls are 1,000 m, 1,200 m, and 1,380 m. The initial elevations of the rockfall/avalanches are 1,193 m, and 1,075 m. The mean initial elevation of debris slides is 768 m. The range of debris slide elevations far exceeds those of rockfalls and rockfall/avalanches at 150 - 1,350 m. Above 1,350 m landslides are infrequent, however, active rockfall, talus build up and snow avalanches are not uncommon. Table 5.2 compares the percentage of the study area occupied by each 300 m (after the first 150 m) of elevation, to the percentage of total number of landslides whose initiation zones are in that same range. More than 50% (16) of the landslides initiated at elevations between 750 m and 1,000 m.

Initiation elevations vary with subdrainage (Table 5.3). Tsitika River, which contains the largest area, also has the greatest range in elevation of landslides. In contrast, landslides in Thursday Creek show relatively uniform initiation heights. Landslides in Schmidt Creek, Russell Creek, Claude Elliott Creek and Tsitika Lake all have ranges on the high side of average (greater than or equal to 820 - 1350 m) whereas Catherine Creek has ranges from 310 - 860 m. The Tsitika River and Catherine Creek have been

Elevation (m)	area (km <sup>2</sup> )	area (%)	landslides (%)
0-150	15	4	3
150-450	76	21	13
450-750	105	29	13
750-1050	88	24	52
1050-1350	69	19	16
> 1350	13	4	3

Table 5.2: Landslides per 300 m of elevation (after the first 150 m).

Subdrainage	Elevation range (m)	Elevation mean (m)	Std. Dev.
Tsitika River	150-1380	836	448
Schmidt Creek	820-1280	959	193
Thursday Creek	600-920	798	115
Catherine Creek	310-860	528	221
Claude Elliott Creek	900	900	0
Tsitika Lake	920-1250	1085	233
Russell Creek	850-1350	1067	256

Table 5.3: Initial elevations of landslides compared to subdrainage.

broadened by glaciation, allowing for steep deposits of morainal material at low elevations.

Figure 5.6 compares initiation elevation to area (area is discussed in detail in section 5.6). The bulk of all landslides can be seen, as described previously, grouped between 750 and 1,000 m. There is in addition, a loose relationship whereby larger landslides occur at higher elevations. For example, all landslides greater than or equal to 37,500 m<sup>2</sup> occur at elevations of 550 m or more. Landslides greater than or equal to 60,000 m<sup>2</sup> occur at elevations of 800 m or higher, and landslides greater than 110,000 m<sup>2</sup> occur at elevations greater or equal to 900 m. The concave shape of slopes, described below and in the definitions, supports the general observation that higher elevations have steeper slopes. In addition, the likelihood of a long potential runout zone increases with elevation.

Landslide sites which produced multiple events may have included initial elevations lower than those described here. In such a situation, where a smaller event was overridden by a larger event, only data for the larger event was recorded.

#### **5.4 Gradient**

The Tsitika study area is characterized by several high peaks and glacially oversteepened valleys (see section 2.0). As a result, gradients are steep, and landslides are generally concave in profile (see section 4.1). Upper slopes are typically erosional and characterized by exposed scarps, whereas lower gentler slopes are the depositional areas.

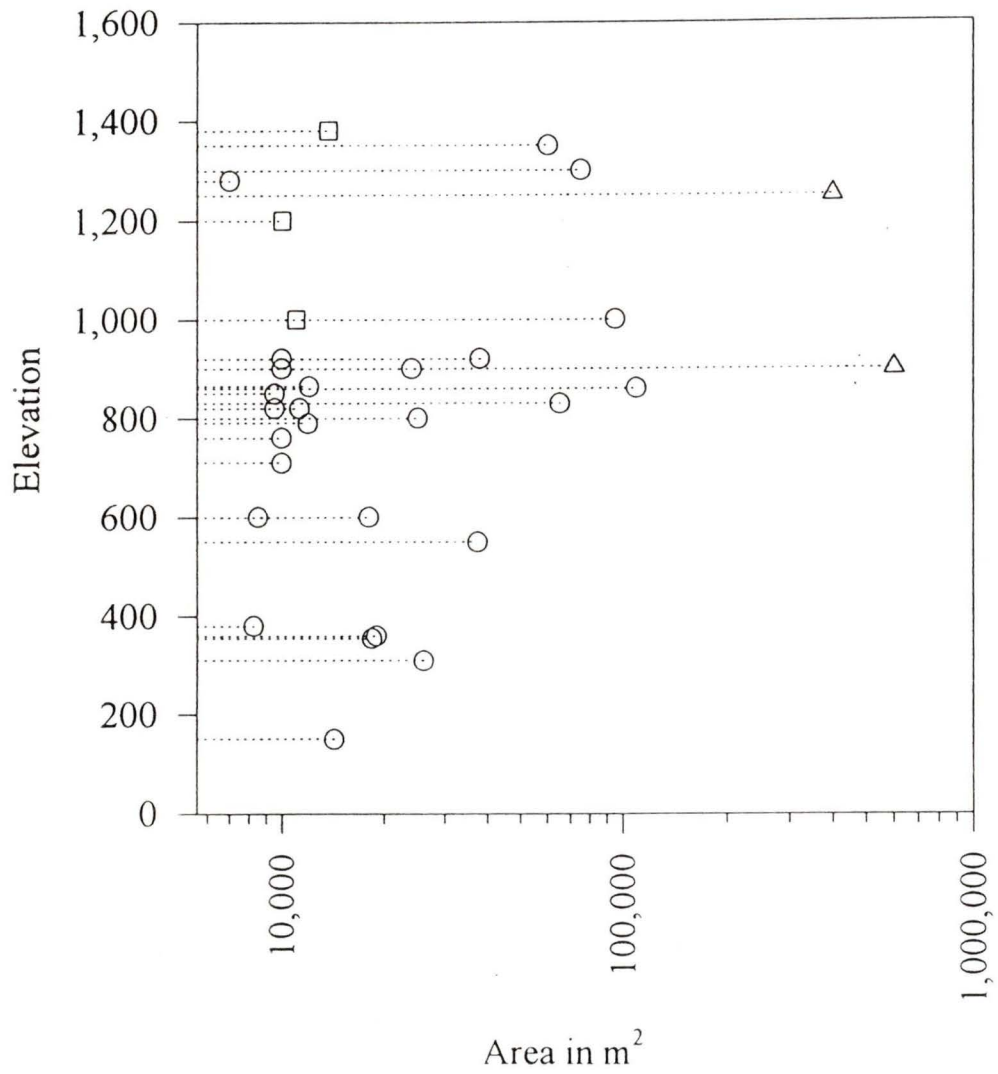

Figure 5.6: Initial elevation versus area.

Landslide gradients generally reflect the slope of the surrounding topography. Mid-slope gradients of the 31 landslides in the study area range from 21 - 45°. Upper and lower-slope gradients range from 26 - 90° and 5 - 45° respectively. Table 5.4 and Figure 5.7 describe the distribution of landslide gradients in the study area.

Subdrainage	Lower-slope			Mid-slope			Upper-slope		
	mean	range	std. dev.	mean	range	std. dev.	mean	range	std. dev.
Tsitika River	28.4	5-45	13	35.6	22-45	6.8	52	35-90	23.7
Schmidt Creek	23	19-27	3.4	33.8	31-36	1.8	39.8	34-45	5
Thursday Creek	23.8	20-27	3	31	27-32	2	34.8	34-35	0.4
Catherine Creek	20.5	15-26	4	31	24-35	7.6	37.8	26-45	8.2
Claude Elliott Creek	5	5	0	25	25	0	45	45	0
Tsitika Lake	14.5	21-25	4.9	23	21-25	2.8	62	34-90	40
Russell Creek	25.7	16-43	15	32.3	27-43	8.1	58	40-90	27.8

Table 5.4: Distribution of landslide gradients in the study area.



Figure 5.7: Gradients of landslides

Landslide gradients in Catherine Creek, Thursday Creek and Schmidt Creek, have a smaller range than those in the other subdrainages. This is indicative of uniform slopes. In Tsitika Lake and Claude Elliott Creek this is strongly biased by the rockfall/avalanches, which (see definitions section 4.1) run out a long distance over a low slope angle.

Figure 5.7 shows the difference in landslide gradients. Rockfalls in the study area occur on vertical cliffs and runout gradients remain steeper than the upper-slopes of some debris slides. Runout gradients for two rockfalls (RC02 and TR08) are steeper than would be expected ( $43^\circ$  and  $45^\circ$ ). In both cases runout is limited by a stream.

Rockfall/avalanches (TL02 and CL01) were observed to have steep upper-slopes but low mid and lower-slope gradients. Debris slides range from upper-slopes generally less than  $45^\circ$ , mid-slopes averaging about  $31^\circ$ , ranging from less than  $20^\circ$  up to  $45^\circ$ , and lower-slopes generally between  $20 - 30^\circ$ .

## 5.5 Runout

Runout was calculated as the length of the landslide from the apex to the toe. It does not describe the distance travelled by debris which may have been transported downstream by a different process (such as incorporation into a channelized debris flow). Runout ranges of the landslides in the study area from 150 - 1,800 m (Appendix I). Runout lengths are shortest in the rockfalls at 230 m, 400 m, and 500m. Debris slides average 585 m in length, and the two rockfall/avalanches are 1,800 m and 1,250 m in length. Runout is restricted geographically by streams at 71% of landslide sites.

Landslides entering a stream may trigger, or supply sediment for debris flows, thereby greatly increasing the distance of sediment transport.

## 5.6 Area

Landslide areas examined in the Tsitika study area range from 7,000 - 600,000 m<sup>2</sup> (Figure 5.8). In the case where more than one event was documented at a site, the area of the largest event was recorded. Table 5.5 shows descriptive statistics of the landslide areas relative to type of movement. Debris slides and rockfalls smaller than 7,000 m<sup>2</sup> occur within the study area but were not examined in this study. The mean area for debris slides is slightly less than 29,000 m<sup>2</sup>. Rockfall areas are significantly less than debris slide areas (table 5.5), but the sample size is very small (three). The two rockfall/avalanches are both very large, at 400,000 m<sup>2</sup> and 600,000 m<sup>2</sup> respectively.

Landslide areas vary spatially with subdrainage, bedrock and surficial geology (Figures 5.9, 5.10, and 5.11 respectively, and Tables 5.6 and 5.7).

Landslide type	number	range	mean	mode	std. dev.
Debris slide	26	7,000-109,400	28,613	10,000	28,512
Rockfall	3	10,000/11,000/13,700	n/a	n/a	n/a
Rockfall/avalanche	2	400,000/600,000	n/a	n/a	n/a
Total	31	7,000-500,000	54,150	10,000	109,715

Table 5.5: Area statistics (in m<sup>2</sup>) for landslide types in the study area.

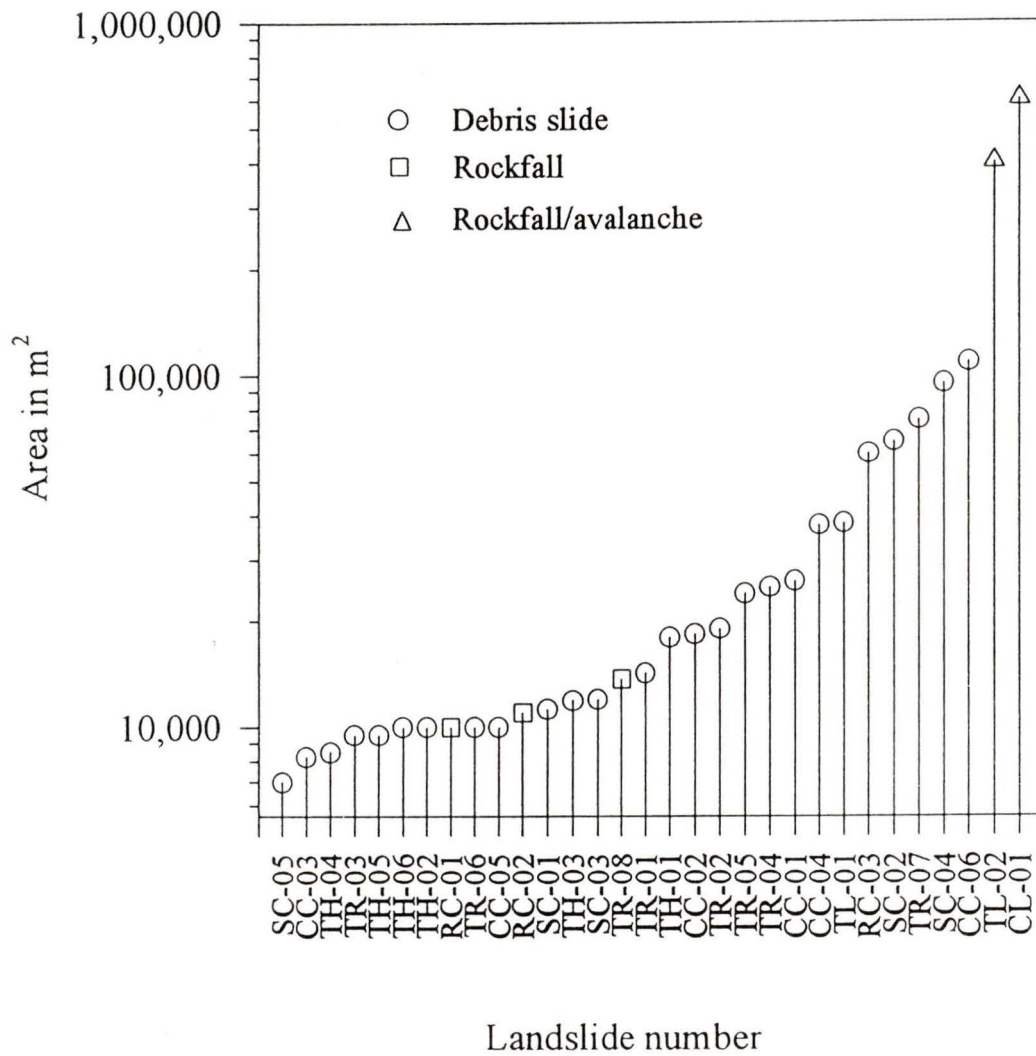

Figure 5.8: Landslide areas.

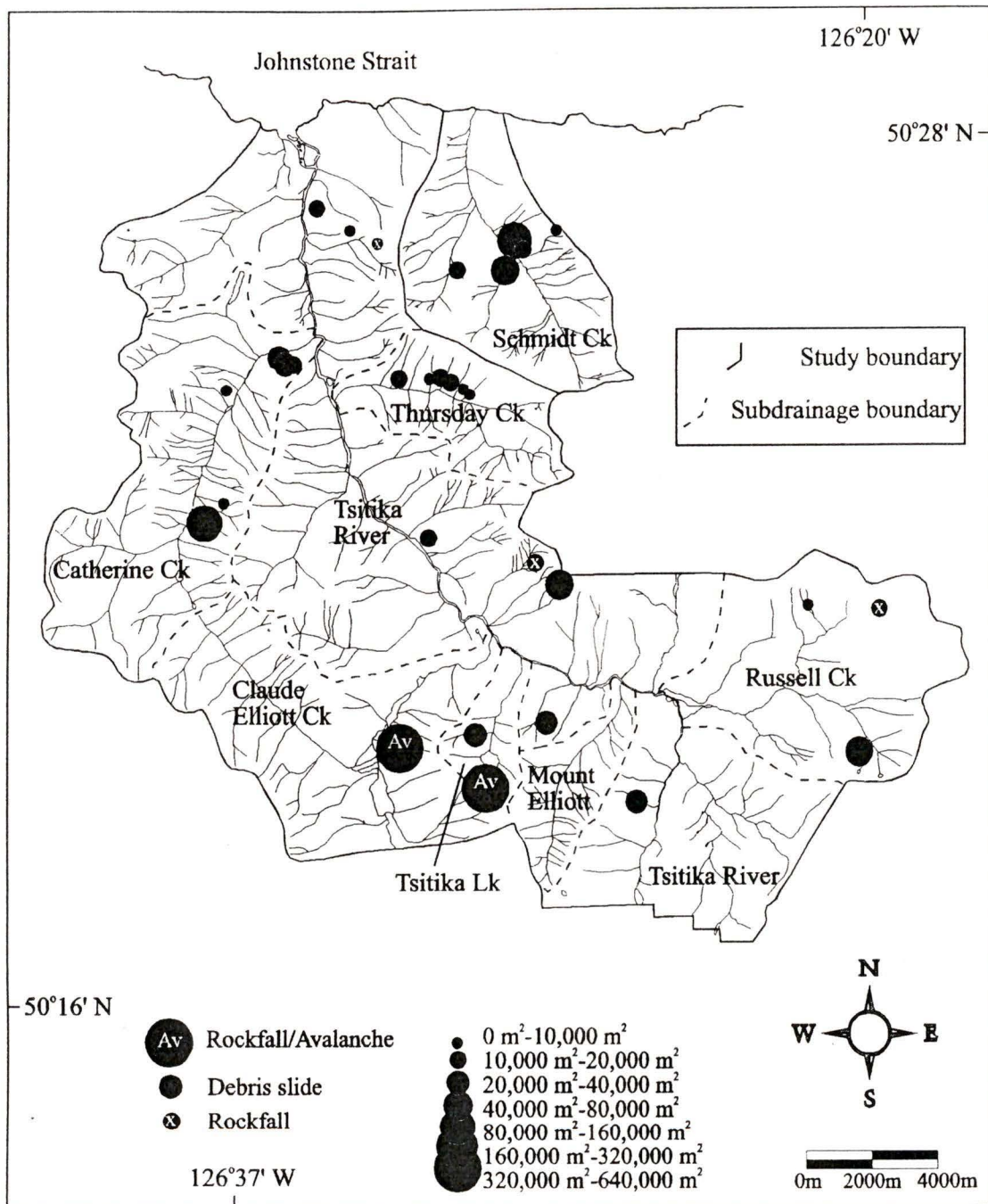

Figure 5.9: Distribution of landslide areas in the Tsitika study area.



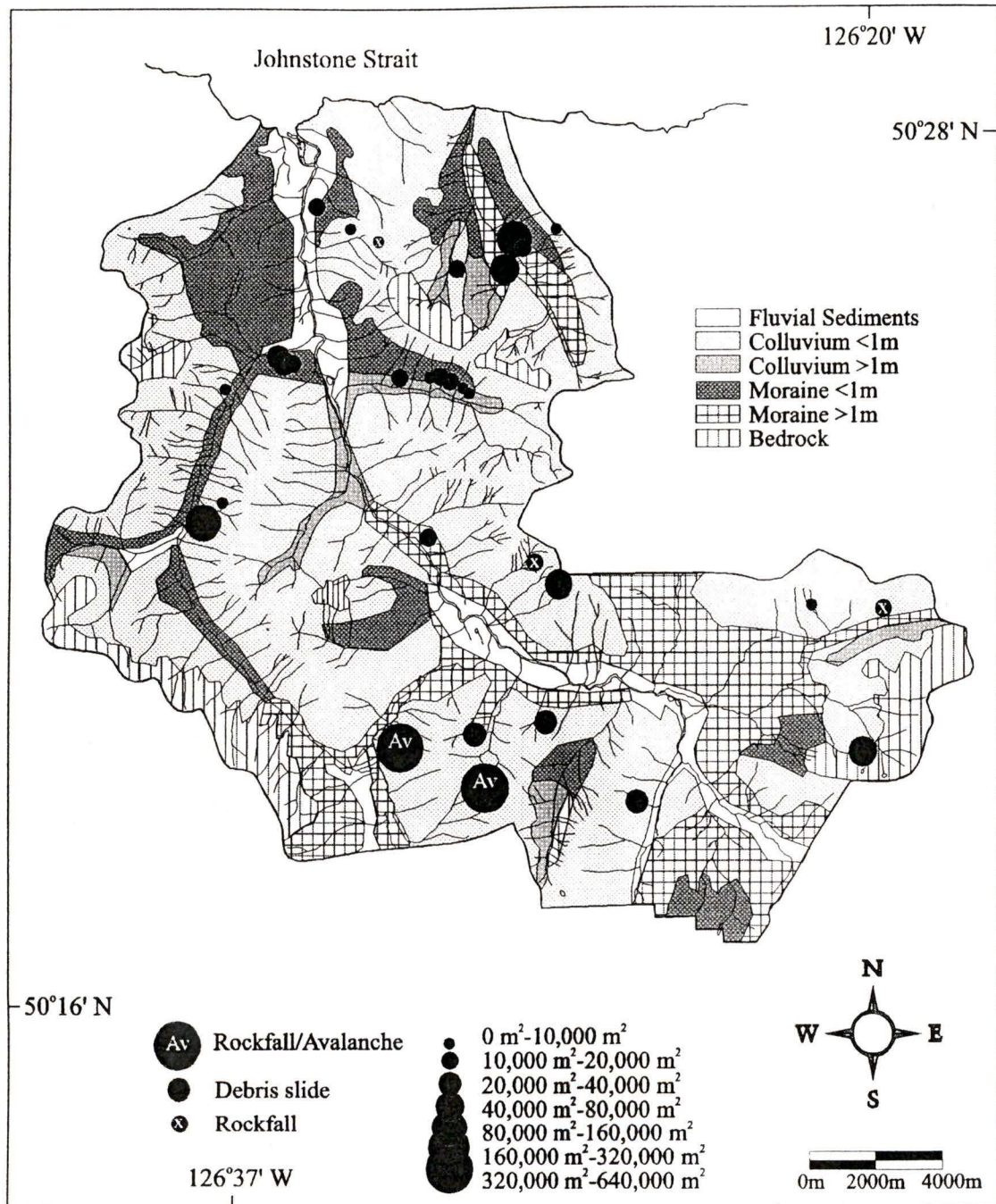

Figure 5.11: Landslide areas compared to surficial geology.

	Tsitika River	Schmidt Creek	Thursday Creek	Catherine Creek
Debris slide mean area	27,625	38,050	11,817	34,925
Debris slide range	8,500-75,000	7,000-65,000	10,000-18,000	8,250-109,400
Debris slide std. dev.	24,014	39,782	3,260	38,049
Rockfall areas	10,000/13,700	0	0	0
Rockfall/avalanche areas	0	0	0	0
	Claude Elliott Creek	Tsitika Lake	Russell Creek	Mount Elliott
Debris slide mean area	0	38,000	34,750	0
Debris slide range	0	38,000	9,500-60,000	0
Debris slide std. dev.	0	0	35,709	0
Rockfall areas	0	0	11,000	0
Rockfall/avalanche areas	600,000	400,000	0	0

Table 5.6: Distribution of landslide areas in the Tsitika study area (in m<sup>2</sup>).

	Island Intrusives	Karmutsen Volcanics	Morainal sediment	Colluvial sediment
Debris slide mean area	29,250	28,347	26,253	31,695
Debris slide range	9,500-60,000	7,000-109,400	10,000-95,000	7,000-109,400
Debris slide std. dev.	17,680	31,465	24,382	34,449
Rockfall areas	11,000	10,000/13,700	0	10,000/11,000/13,700
Rockfall/avalanche areas	400,000/600,000	0	0	400,000/600,000

Table 5.7: Distribution of landslide areas relative to bedrock and surficial geology (in m<sup>2</sup>).

Thursday Creek displays the most uniform of landslide areas, in contrast to all other subdrainages. The structural geology of Thursday Creek (Figure 5.10) indicates southward dipping bedrock (Karmutsen Volcanics) at about  $10^{\circ}$ . In addition, the surficial geology (Figure 5.11) indicates a morainal veneer overlies this slope, extending to roughly the elevation at which the slides initiate. Other influencing conditions, such as a long uniform slope are also more common in Thursday Creek.

Other subdrainages; Catherine Creek, Tsitika River, Schmidt Creek and Russell Creek exhibit wider variations in landslide areas, but they also exhibit more differences physiographically and geologically. Tsitika Lake and Claude Elliott Creek contain the two rockfall/avalanches, which occur in both cases on the Vernon Batholith. Claude Elliott Creek is otherwise lacking discrete events. This is also true for Mount Elliott. Both areas, however, are subject to active mass movement processes such as active rockfall and snow avalanching (Figure 5.2).

Six (66%) of the landslides underlain by the Island Intrusives are greater than  $20,000 \text{ m}^2$  and only one is  $9,500 \text{ m}^2$ . In contrast, only six (27%) of the landslides underlain by the Karmutsen Volcanics are over  $20,000 \text{ m}^2$ , and 8 (36%) landslides are  $10,000 \text{ m}^2$  or less. However, 20 (91%) of landslides underlain by the Karmutsen Volcanics are debris slides (Figure 5.10) versus only six (66%) of the landslides underlain by the Vernon Batholith. The range of debris slide areas is considerably greater over the Karmutsen Volcanics.

Debris slides exhibit a wide range of areas in both colluvial and morainal sediments (Table 5.7, Figure 5.11).

## 5.7 Volume

Volumes of the 31 landslides noted in the Tsitika study area range from 3,200 - 500,000 m<sup>3</sup> (Figure 5.12) and exhibit a linear relationship with area (Figure 5.13). Debris slides have the widest range of values, averaging 22,065 m<sup>3</sup>. Rockfalls and rockfall/avalanches are clustered at both ends of the scale, averaging 7,167 m<sup>3</sup> and 500,000 m<sup>3</sup> respectively. Volumes were estimated for the total amount of sediment moved on all 31 sites. Figure 5.14 shows the distribution of landslide volumes in the Tsitika study area.

Twenty three percent (seven) of the landslides in the study have area to volume ratios less than or equal to 1:1 indicating landslide thickness was greater than 1 m. Six of those landslides are debris slides and one is a rockfall/avalanche.

Seventy seven percent (24) of the landslides have area to volume ratios between 1:1 and 2:1. This includes 20 debris slides, all three rockfalls, and one of the rockfall/avalanches.

Twenty six percent (eight) of the landslides have area to volume ratios greater than 2:1, indicating landslide thicknesses less than 0.5m. All eight are debris slides.

All but one of the six debris slides with an area to volume ratio less than or equal to 1:1 occur in either the Catherine Creek (three) or Thursday Creek (two) subdrainages. The other occurs in the Tsitika River subdrainage.

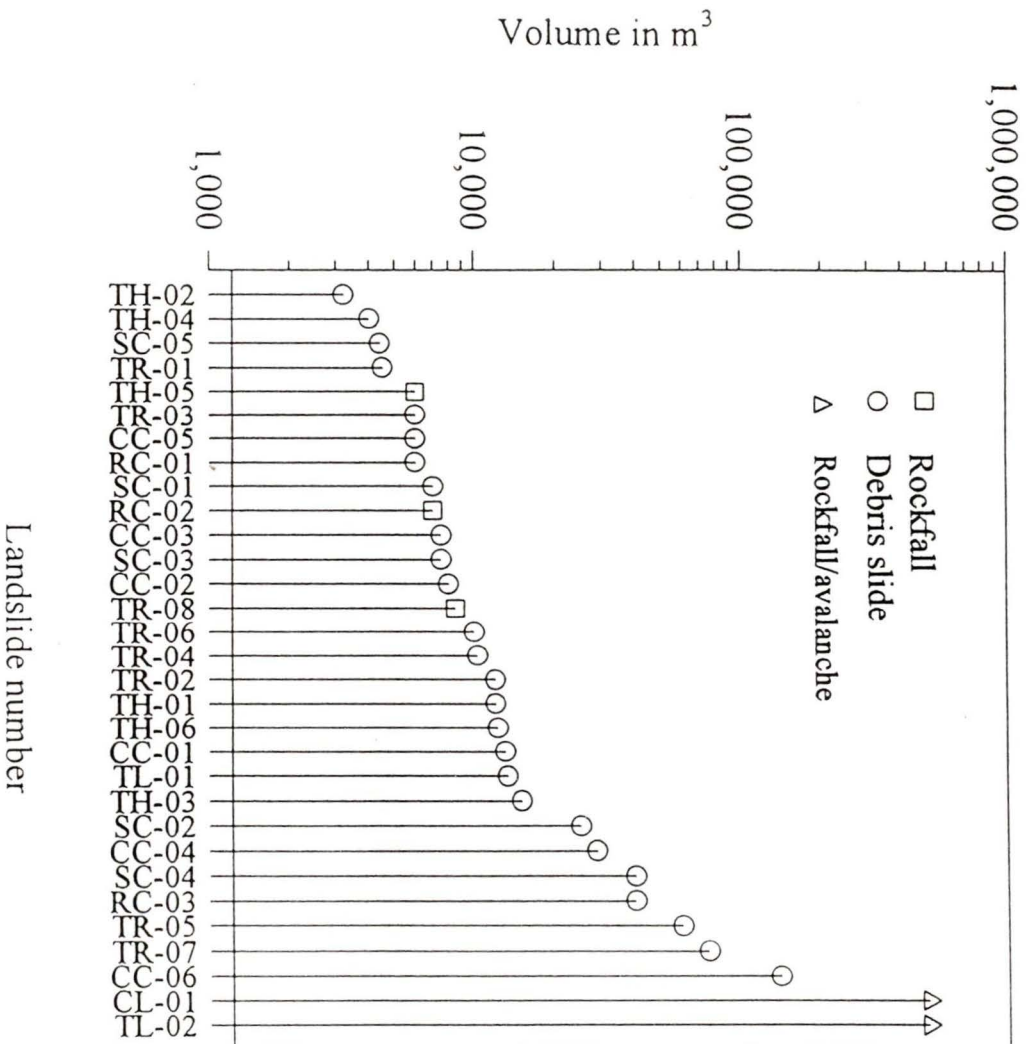

Figure 5.12: Landslide volumes.

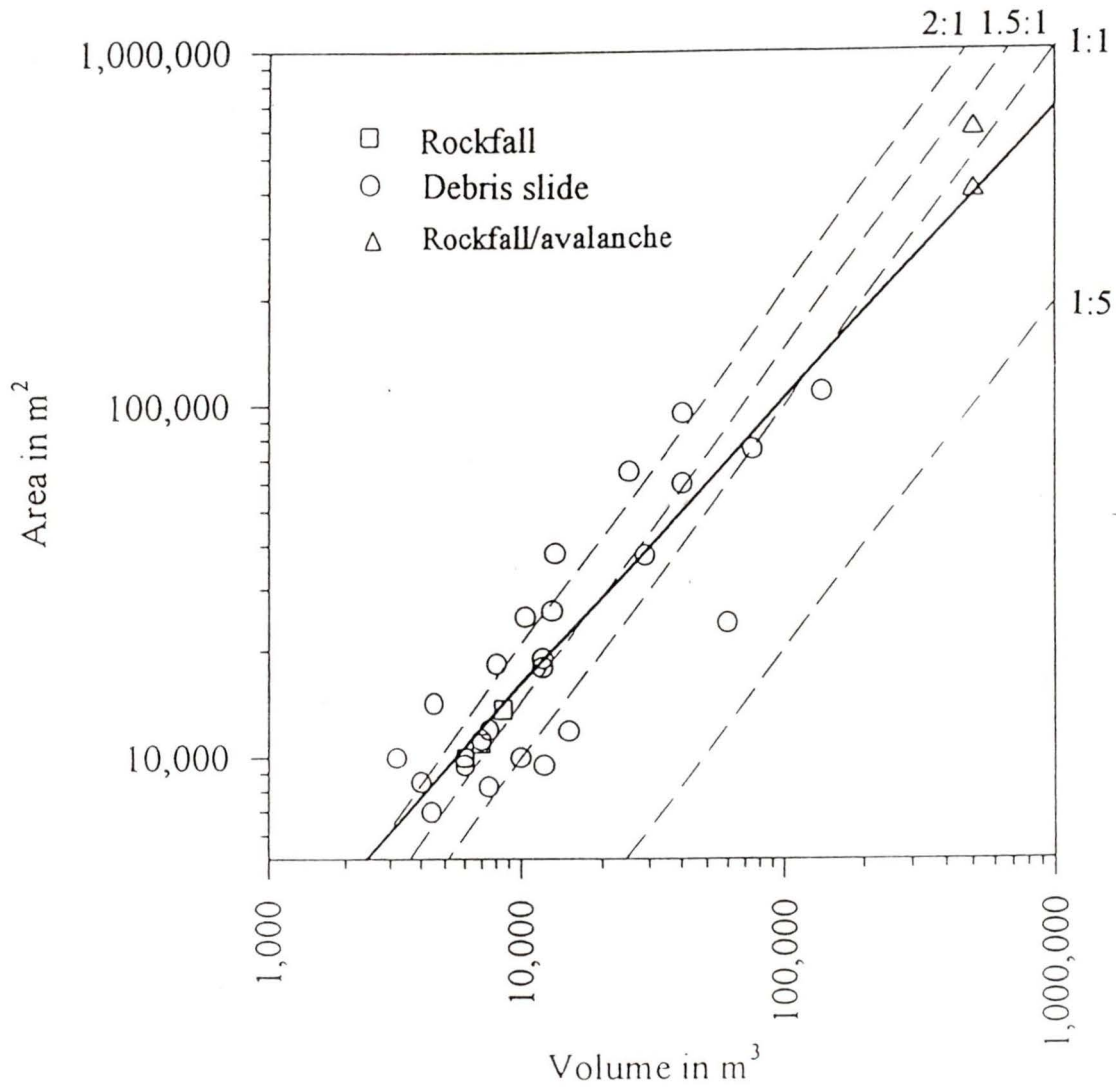

Figure 5.13: Comparison between landslide areas and volumes.

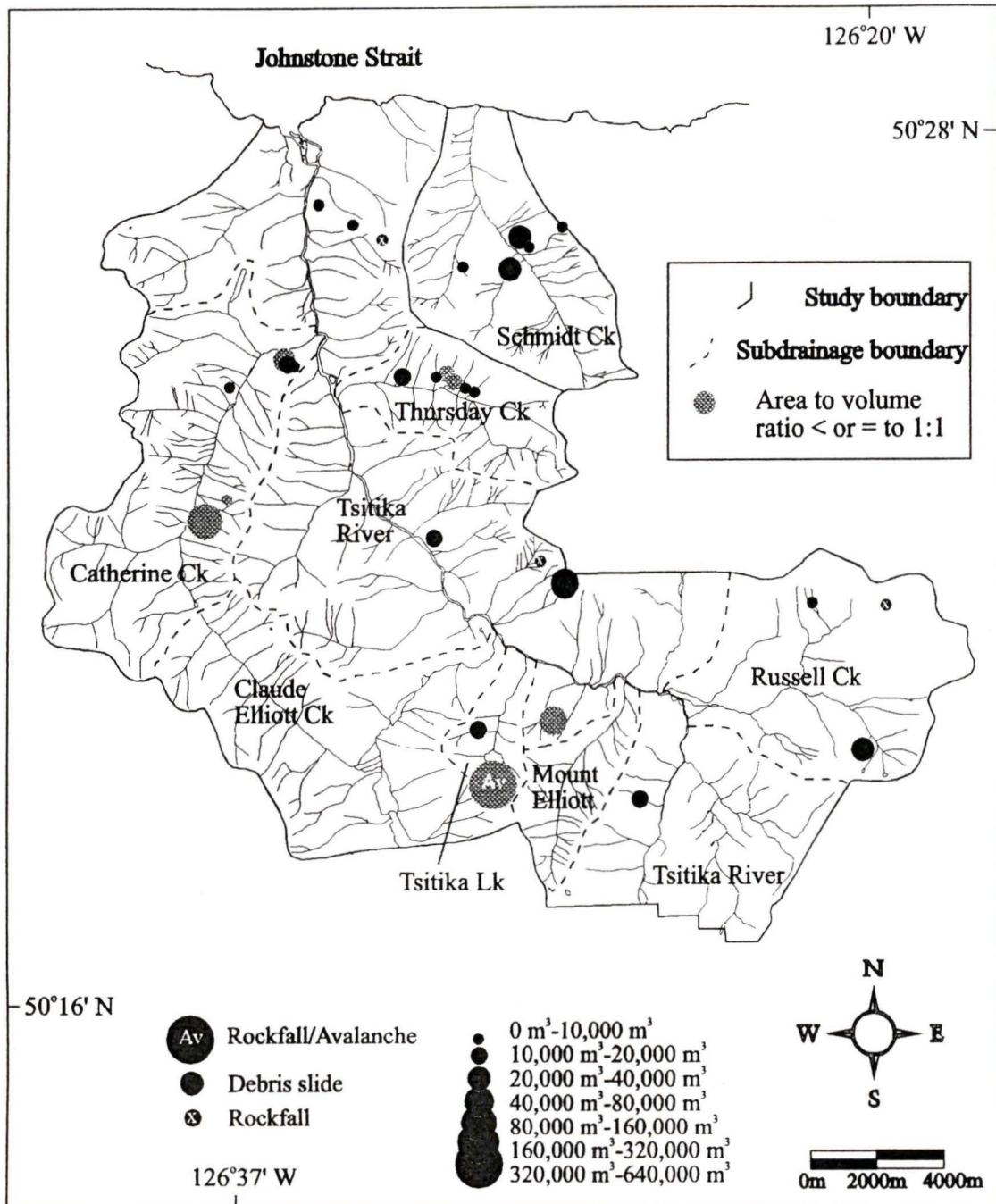

Figure 5.14: The distribution of landslide volumes in the study area.

### 5.7.1 Volume to Stream

The Tsitika River is contained by a fifth order basin and Schmidt Creek by a fourth order basin (Hewlett, 1982, British Columbia Ministry of Forests, 1995c). The majority of significant channels in the study area are of third order. Twenty three (approximately 74%) landslides in the study deposited sediment into a channel. Of these, one was deposited into a fourth order channel. Twelve of the landslides deposited sediment into third order channels, eight into second order channels, and two into first order channels. Table 5.8 shows the distribution of volumes of sediment into stream channels. Figure 5.15 and Table 5.9 describe the spatial distribution of these landslides. The volumes in Table 5.9 describe a large amount of sediment deposited in a fourth order channel at Claude Elliott Creek, and in a first order channel at Tsitika Lake. Both these results are caused by rockfall/avalanches. Rockfall/avalanches are large and uncommon in the study; features that skew the results, yet are nevertheless significant in terms of sediment input to the watershed.

Log jams and islands, blocked streams and altered drainage patterns caused by sediment and debris from landslides have occurred throughout the study area, but are especially evident in Catherine Creek, Schmidt Creek, Claude Elliott Creek, and Thursday Creek. In general, lower order channels occur on steeper grades. As a result, second and third order channels have little or no floodplain relative to fourth or fifth order channels,

Channel order	Total volume	Mean volume	number
5	0		
4	250,000	n/a	1
3	122,400	10,200	12
2	176,800	25,257	7
1	101,200	n/a	2
total	650,400	30,971	22

Table 5.8: Amount of sediment into stream channels (m<sup>3</sup>).

Subdrainage	Volume/stream order					Total Volume
	5	4	3	2	1	
Tsitika River	0	0	0	140,000	1,200	141,200
Schmidt Creek	0	0	46,000	3,500	0	49,500
Thursday Creek	0	0	26,400	0	0	26,400
Catherine Creek	0	0	50,000	10,000	0	60,000
Claude Elliott Creek	0	250,000	0	0	0	250,000
Tsitika Lake	0	0	0	13,300	100,000	113,300
Russell Creek	0	0	0	10,000	0	10,000

Table 5.9: Distribution of landslide volumes to streams in the study area (in m<sup>3</sup>)

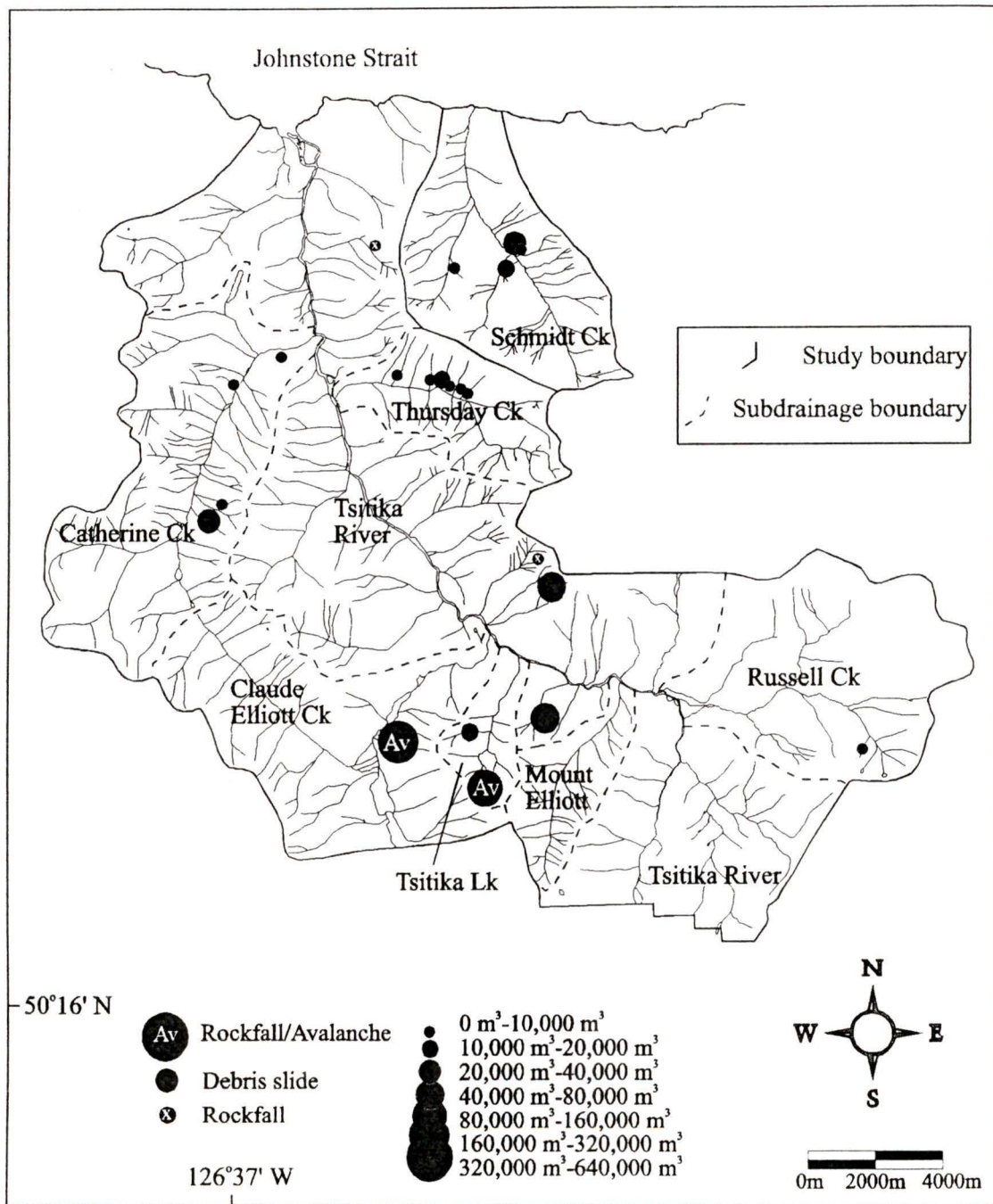

Figure 5.15: The distribution of landslide volumes to streams in the study area.

and slope breaks, if they occur, are more likely to occur nearer to the stream.

## 5.8 Precipitation

Frequency analysis of precipitation values were obtained for 73 years (1914-1915, 1924-1993) at Alert Bay, and for 18 years (1921-1928, 1974-1981, 1988-1989) at Sayward (unpublished data, Environment Canada, Climate and Environmental Applications Pacific and Yukon Region, Vancouver, British Columbia, 1994). Table 5.10 summarizes these data. Values at the Sayward station are higher than those at Alert Bay, however, mean values are well within one standard deviation of each other. Sayward precipitation data are missing several years of data. These data correspond to years of lower values at Alert Bay, and values for Sayward are, therefore, assumed to be biased toward greater amounts of precipitation and the results were not used in primary analysis.

At Alert Bay, the most precipitation typically occurs in the winter months, and specifically during the month of November. Mean monthly precipitation for that month is 230.8 mm. On average, the driest month is July, with a mean 54.1 mm of precipitation. Figure 2.8 shows the average monthly precipitation at Alert Bay. Additional information on the regional climate is given in section 2.2 of the study area.

Hogan and Schwab (1991a) found that precipitation intensity in the Queen Charlotte Islands was most intense in the first 24 hours of a storm, and intensity decreased with increased duration. Precipitation information at Alert Bay and Sayward is in agreement with this observation.

Alert Bay				
Return Period	1 Day (mm)	2 Days (mm)	3 Days (mm)	30 Days (mm)
1:2 Years	58	77.9	92.7	274.5
1:10 Years	84.5	117	141.1	393.1
1:25 Years	97.9	136.7	165.4	452.7
1:50 Years	107.8	151.3	183.5	540.9
1:100 Years	117.7	165.9	201.4	584.6
1:200 Years	127.5	180.3	219.3	796.9
Sayward				
Return Period	1 Day (mm)	2 Days (mm)	3 Days (mm)	30 Days (mm)
1:2 Years	62.8	85.4	103.9	315
1:10 Years	109.9	131.4	167.8	473.1
1:25 Years	133.6	154.6	199.9	552.6
1:50 Years	151.2	171.8	223.7	611.6
1:100 Years	168.7	188.9	247.4	670.2
1:200 Years	186.1	205.9	271	728

Table 5.10: Frequency analysis of precipitation at Alert Bay and Sayward (unpublished data from M. Miles and Associates, 1996).

Values for one day maximum annual precipitation at Alert Bay, are displayed in order of increasing amount in Figure 5.16. Maximum annual precipitation values for two and three days exhibit a linear relationship with one day maximum values. Return periods at Alert Bay less than 1:10 years are listed in Table 5.11. Seven years have a return period of 1:10 - 1:15 years, five have a return of 1:25 - 1:50 years, and one has a return interval less than 1:50 years.

## 5.9 Seismic

Seismic data was obtained from the Pacific Geoscience Centre in Sidney, British Columbia. Eleven documented seismic events in the last 100 years have resulted in ground accelerations in the study area greater than  $10 \text{ cm/s}^2$  (1%g). This is considered the minimum threshold that is felt by most humans (Bolt, 1978), but is below the threshold necessary for landslides to occur (Keefer, 1984). Table 5.12 and Figure 5.17 display these data.

Of the eleven events data from three are considered unreliable and poorly located (Rogers, personal communication, 1996). These three events include both records from 1917 as well as one from 1919.

Richter (1958) describes an empirical relationship between acceleration and the modified Mercalli intensity scale:

$$\text{Log } a = \frac{I}{3} - \frac{1}{2}$$

where:  $a$  = acceleration in  $\text{cm/s}^2$

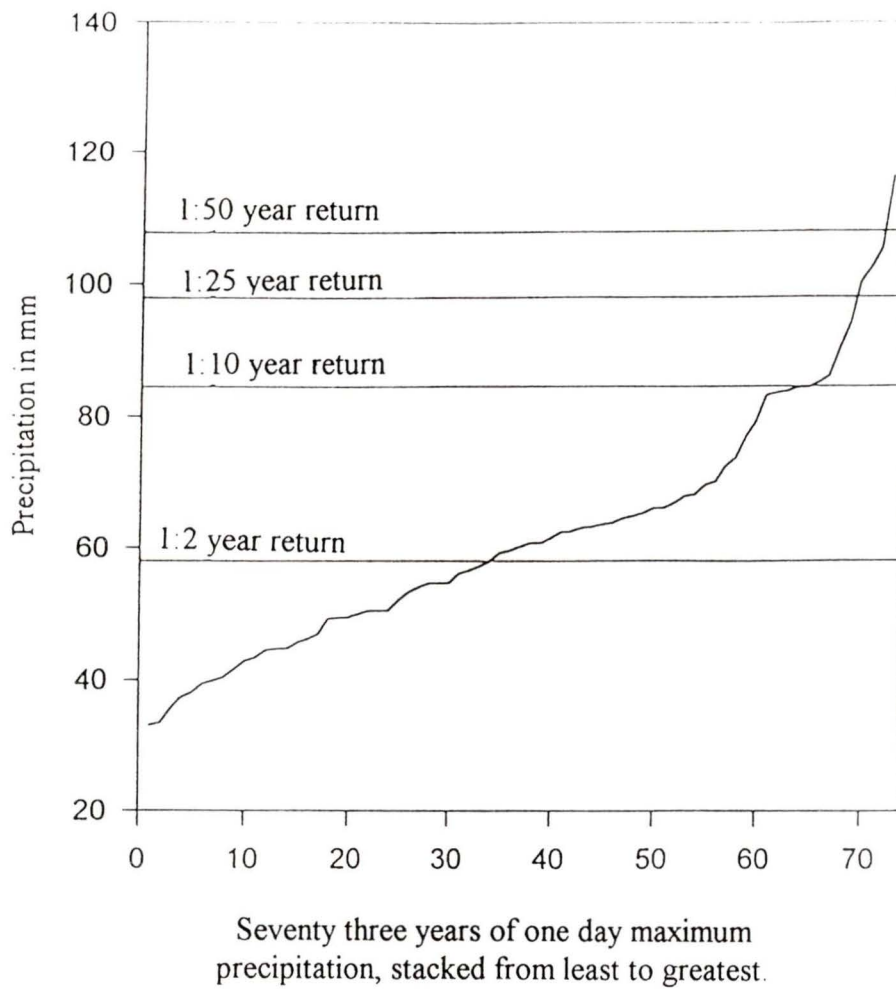

Figure 5.16: One day maximum annual precipitation for 73 years of record at Alert Bay, and return periods (from unpublished data, Environment Canada, 1994, and M. Miles and Associates, 1996).

Return Interval (years)		
1:10-1:25	1:25-1:50	<1:50
1940	1926	1975
1947	1930	
1952	1946	
1962	1963	
1968	1971	
1973	1977	
1983		

Table 5.11: Return intervals at Alert Bay less than 1:10 years (from unpublished data, Environment Canada, 1994, and M. Miles and Associates, 1996).

Year	Month	Day	Latitude (N)	Longitude (W)	Magnitude (Richter)	Acceleration (cm/s <sup>2</sup> )
1917	7	1	50.00	128.00	6.4	21.90
1917	12	23	50.00	128.00	6.5	23.09
1918	12	6	49.44	126.22	6.9	44.30
1919	7	1	50.00	128.00	5.5	13.63
1927	5	7	50.15	127.85	5.5	17.67
1939	2	8	49.14	127.71	6.5	13.90
1946	6	23	49.76	125.34	7.3	41.52
1957	12	16	49.64	127.00	5.9	31.72
1972	7	5	49.49	127.27	6	23.29
1978	6	2	50.15	127.83	5.2	15.50
1978	7	25	50.15	127.83	5.1	14.71

Table 5.12: Seismic activity which resulted in movement greater than 10 cm/s<sup>2</sup> (1% gravity) in the Tsitika study area (unpublished data from Bob Horner and Dieter Weichert, 1995 at the Pacific Geoscience Centre, Sidney, B.C.).

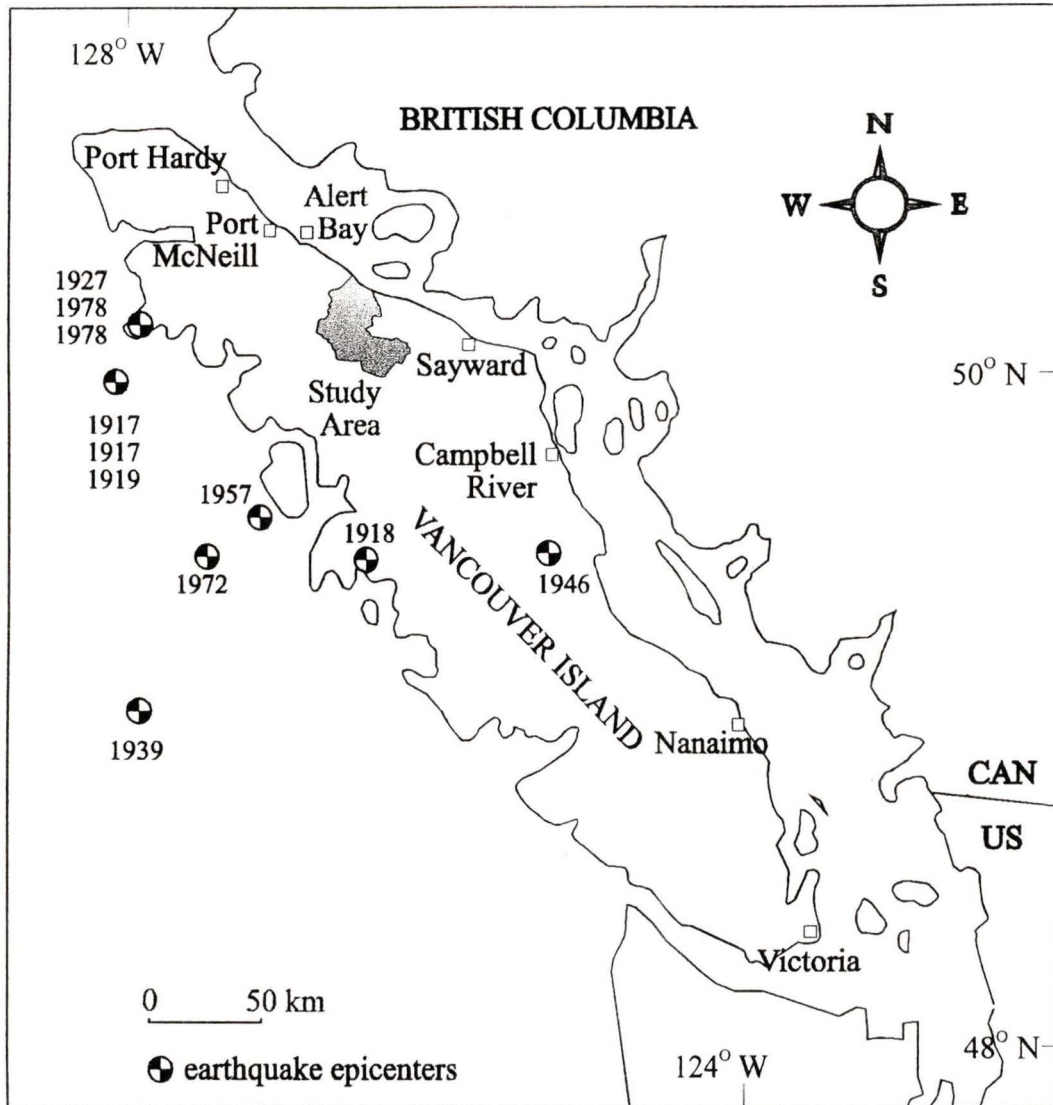

Figure 5.17: Location map of seismic events which resulted in accelerations equal to or greater than  $10 \text{ cm/s}^2$  in the study area (unpublished data from Horner and Weichert at the Pacific Geoscience Center, Sidney, B. C.).

I = intensity

Unfortunately, this formula breaks down with very low and very high accelerations, resulting in higher than expected intensities in the first case, and lower than expected intensities in the second case.

Landslides are recognized as occurring at intensities generally greater or equal to VI (Mathews, 1979), and rarely V (Keefer, 1984). Isoseismal maps are commonly derived for earthquakes of significant magnitude, showing the regional distribution of intensities. Isoseismal maps are available for the 1918 (Cassidy *et al.*, 1988), 1946 (Rogers, 1980), 1957 (Cassidy *et al.*, 1988), 1972 (Rogers, 1976), and 1978 (Spindler and Rogers, 1989) events. These isoseismal maps, except for the 1918 and 1946 earthquakes, show regional modified Mercalli intensities in the study area to be less than IV. The earthquakes in 1927 and 1939 do not have associated intensity maps. However, their accelerations are comparable to the 1957, 1972, and 1978 earthquakes. It is unlikely that either the 1927 earthquake, or the 1939 earthquake could have resulted in modified Mercalli intensities of IV or greater in the study area.

Only two recent earthquakes; 1918 and 1946, were found likely to cause intensities equal to or greater than V (Rogers, 1980, and Cassidy *et al.*, 1988). Figures 5.18 and 5.19 show isoseismal maps for the years 1918 and 1946.

Great earthquakes (magnitude greater than or equal to 8) are discussed by numerous authors (Rogers, 1988, 1987, Atwater, 1987, 1992, Adams, 1990, Clague and Bobrowsky, 1994a, 1994b, Wuethrich, 1994, Satake, 1995, Clague, 1996, and others). They are considered to be widely felt and cause large scale regional landsliding. Results of

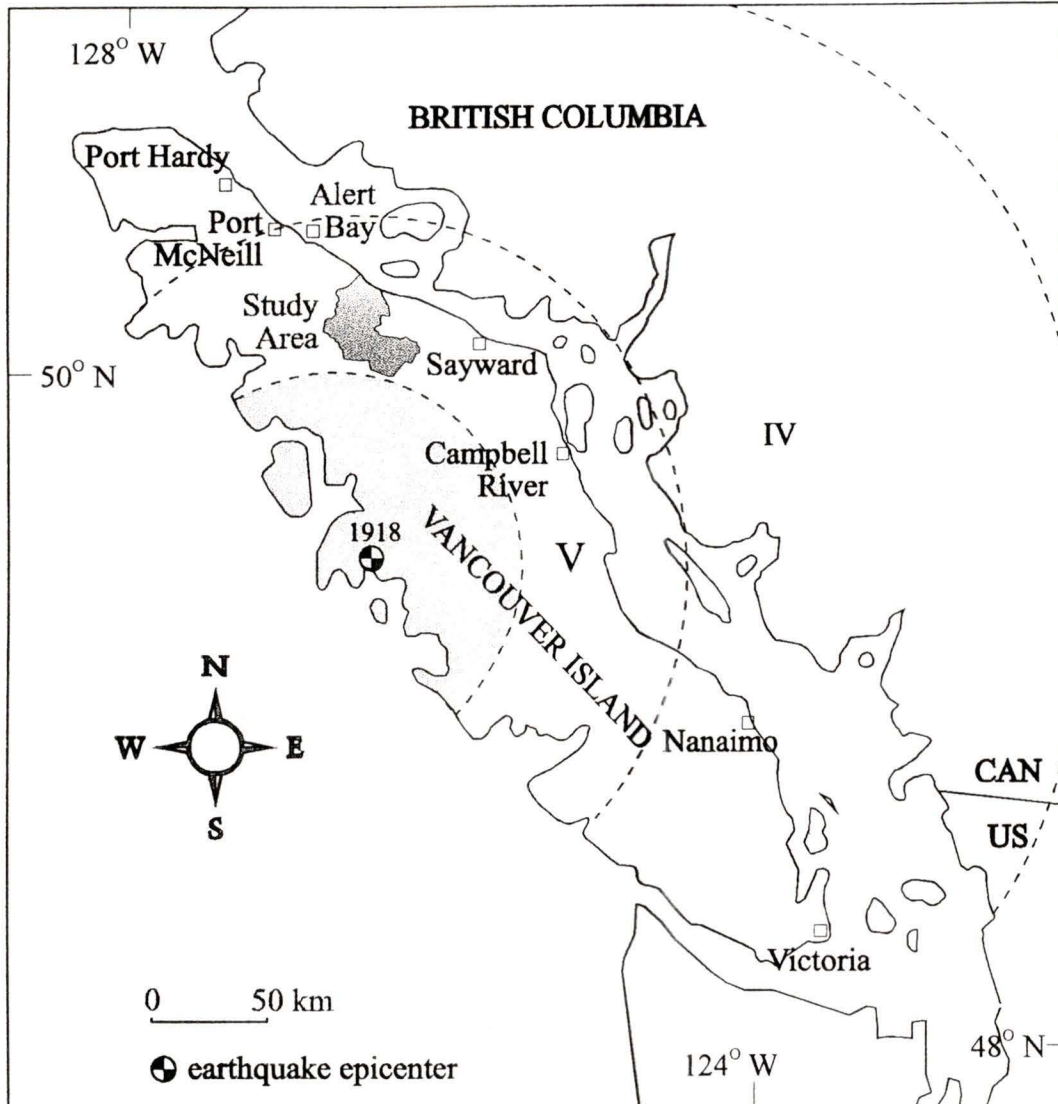

Figure 5.18: Isoseismal map of 1918 earthquake. Roman numerals represent modified Mercalli intensities. Shaded circle experienced intensities of VI and greater (from Cassidy *et al.*, 1988).

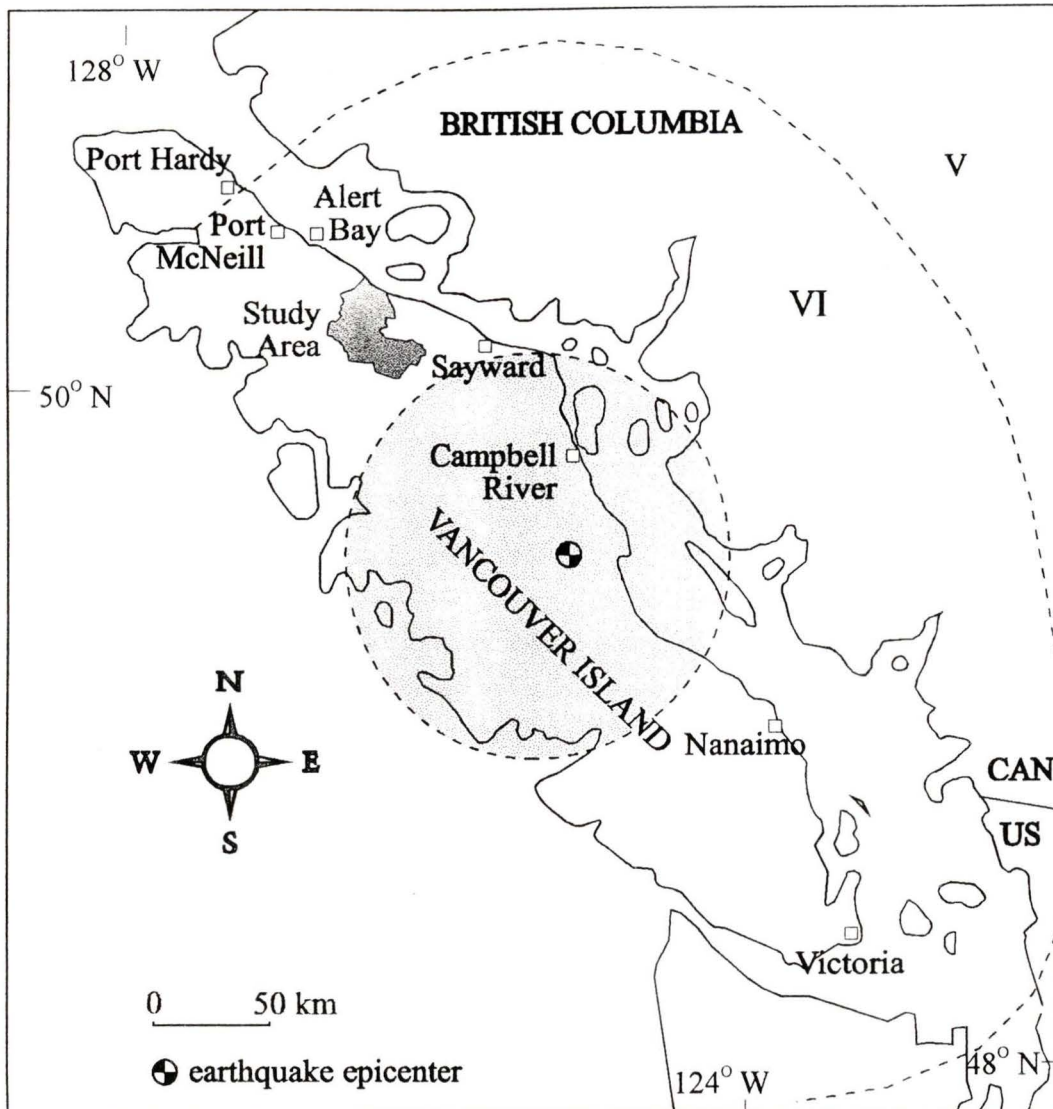

Figure 5.19: Isoseismal map of 1946 earthquake. Roman numerals represent modified Mercalli intensities. Shaded circle experienced intensities of VII and greater (from Rogers, 1980).

the recent research indicate possible dates for the last two great earthquakes as January 26 1700 AD (Satake, 1995), and 1300 +/-130 AD (Adams, 1990).

### 5.10 Landslide Dates

Years of 43 landslide events at 31 landslide sites in the Tsitika study area are given in Figure 5.20. Ages constrained by air photographs, scars or peripheral scars are indicated by brackets on either side of an error bar. Dates with fewer constraints, typically just a minimum age, are indicated by a bracket, error bar and arrow in the direction of uncertainty. In cases where the best information is only a minimum date from an air photo, the error bar is shown as a dashed line. Landslides that have failed within the last 25 years, are the best constrained. There appear to be clusters of activity around 1990, 1977, and 1975.

Landslides that failed more than one time at a given site were noted at 23% (7) of sites. All but one of the repeated events are debris slides, and occurred on a time frame from as little as two years apart, to more than 20 years. The maximum number of events was not determined, as evidence for one event, may be eliminated by another. However, Figure 5.20 shows a minimum number of events, and their relative frequencies.

In Schmidt Creek, SC02 and SC04 failed four and two times respectively. In Tsitika River TR07 failed at least five times. In Thursday Creek TH01 and TH03 both failed at least twice. Finally in Tsitika Lake, both TL01 and TL02 failed at least twice. Figure 5.21 shows the spatial distribution of these landslides.

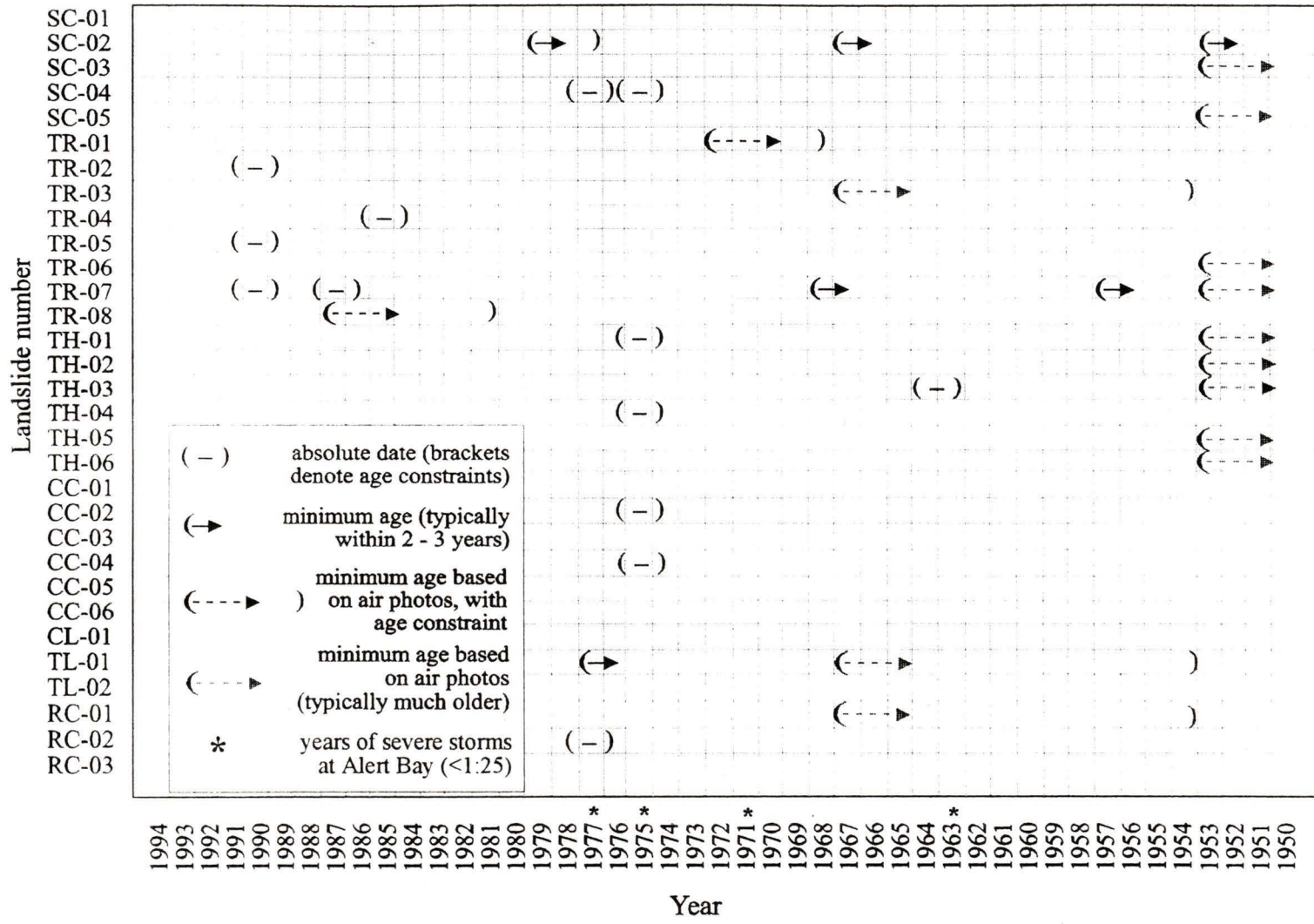

Figure 5.20: Dates of landslides in the Tsitika study area (continued next page).

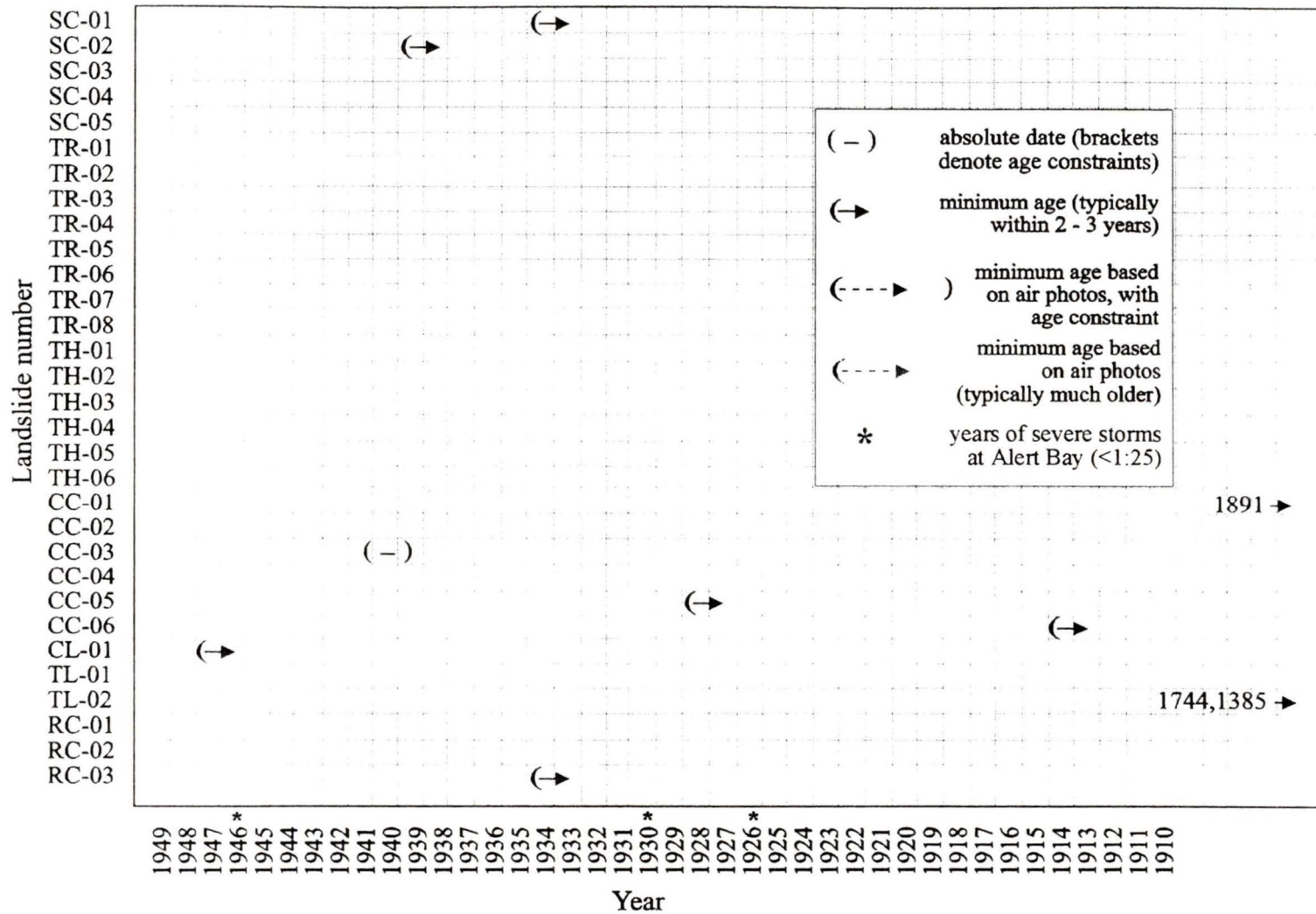

Figure 5.20: Dates of landslides in the Tsitika study area (continued from previous page).

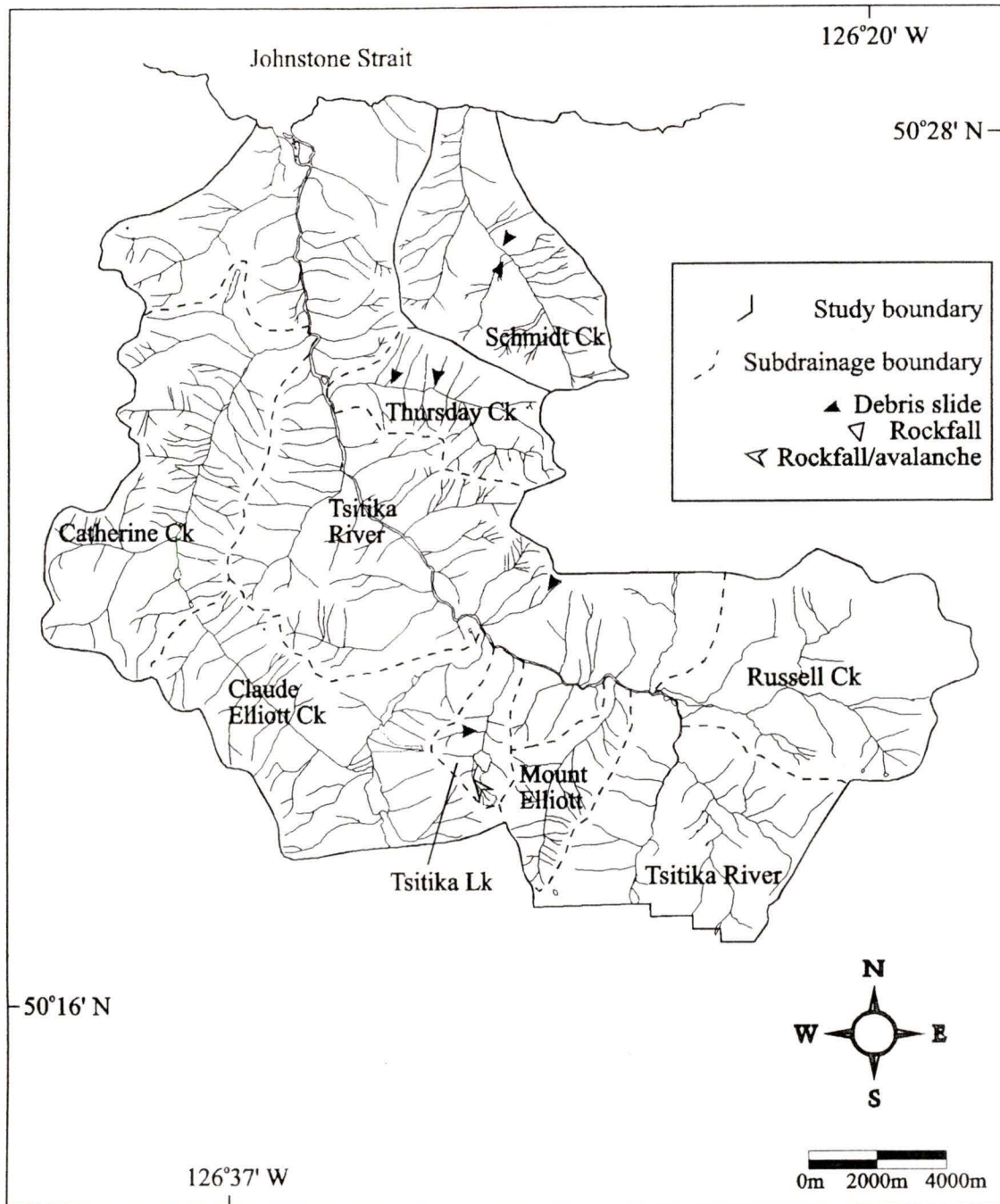

Figure 5.21: The spatial distribution of recurring landslides in the study area.

Seventy five percent of recurring landslides overlie Karmutsen Volcanics. This is proportionate to the total number of landslides that overlie Karmutsen Volcanics. However sediment sources may be site specific, and the additional events are limited to the previously mentioned seven sites. This increased emphasis may skew the results by suggesting a stronger correlation with physical features that caused the mass movement initially, than is warranted. Instead, field observations indicate that debris slides occur repeatedly where there is a continued source of poorly consolidated material and vegetation has difficulty taking root. To this end, all the repeating events occurred in morainal deposits except for TR07 and TL02. TR07, however, occurs in extensively eroded colluvium that remains very unstable.

TL02 is a rockfall/avalanche, and occurred in bedrock. The jointing and fracturing that are associated with the initial failure also likely resulted in the second event. The events occurred approximately 300 years apart. It is unique in the study area in that no other landslides of that age were recorded. In general, the landscape completely recovers from a landslide in less time than that. Nevertheless, it is probable that other landslides occurred 300 and more years ago, and it is possible that they may have been repeat events as well.

All recurring landslides reached a stream and the majority of sediment has been removed. Without doing excavations and extremely detailed cross sections of each landslide, which was beyond the scope of this project, it was not possible to determine the volume contributed by a single event. For this reason, total volumes were determined for

each landslide site, and are described previously in section 5.7. Further implications of multiple events are discussed in section 6.5.

### **5.10.1 Landslide Dates and Precipitation Events**

Only 1975 was observed to have an extreme precipitation return interval of greater than 50 years (at Alert Bay, rainfall was 116.1 mm in 24 hours). Of 31 landslide sites, movements on six (19%, including one minimum age date) were observed to occur that same year. Figure 5.22 shows the distribution and area of these landslides.

Six years (1926, 1930, 1946, 1963, 1971, 1977) were observed to have precipitation return intervals between 1:25 and 1:50. Four of those six years were coincident to landslide activity. Figure 5.23 shows the distribution and area of landslides for the years 1926, 1946, 1963, and 1977 (landslides which may be coincident to 1926 and 1946 are based on minimum age dates of 1928 and 1947, and are expected to be too young by one or two years).

Seven years (1940, 1947, 1952, 1962, 1968, 1973, 1983) were observed to have precipitation return intervals between 1:10 and 1:25. Three (43%) of these years were coincident to landslide activity. The 3 years are 1940, 1952, and 1968 (once again, the relationship between the years 1952, 1968 and year of landslide occurrence is based on minimum age dates).

Precipitation return intervals at Alert Bay greater than 10 years did not occur for 1990. However, 3 debris slides were noted to occur in that year. Anecdotal information from employees at MacMillan Bloedel, Eve River District, recalls a wet year in 1990 in the

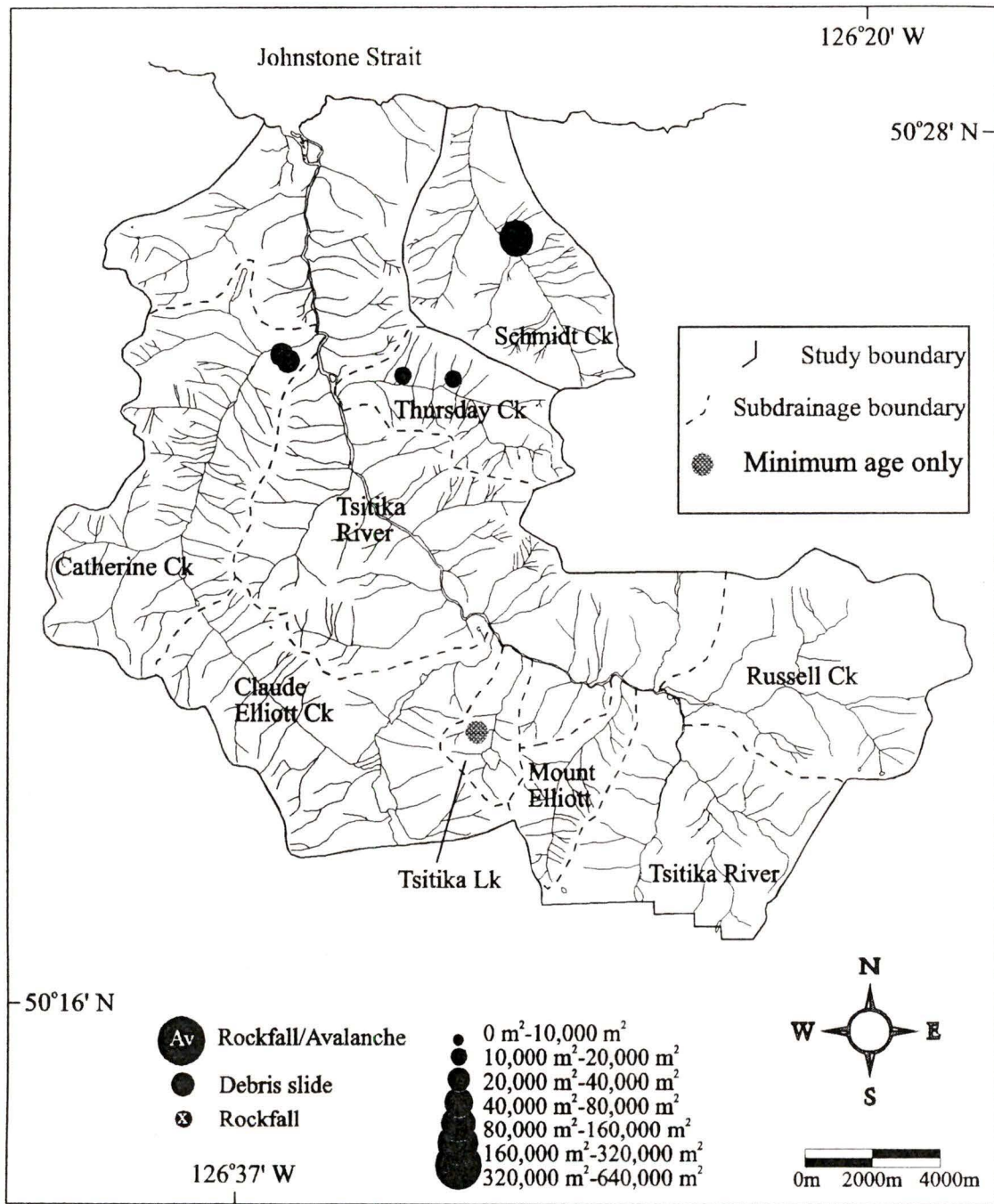

Figure 5.22: Landslides that may have been coincident to the 1975 storm (return interval < 1:50 years).

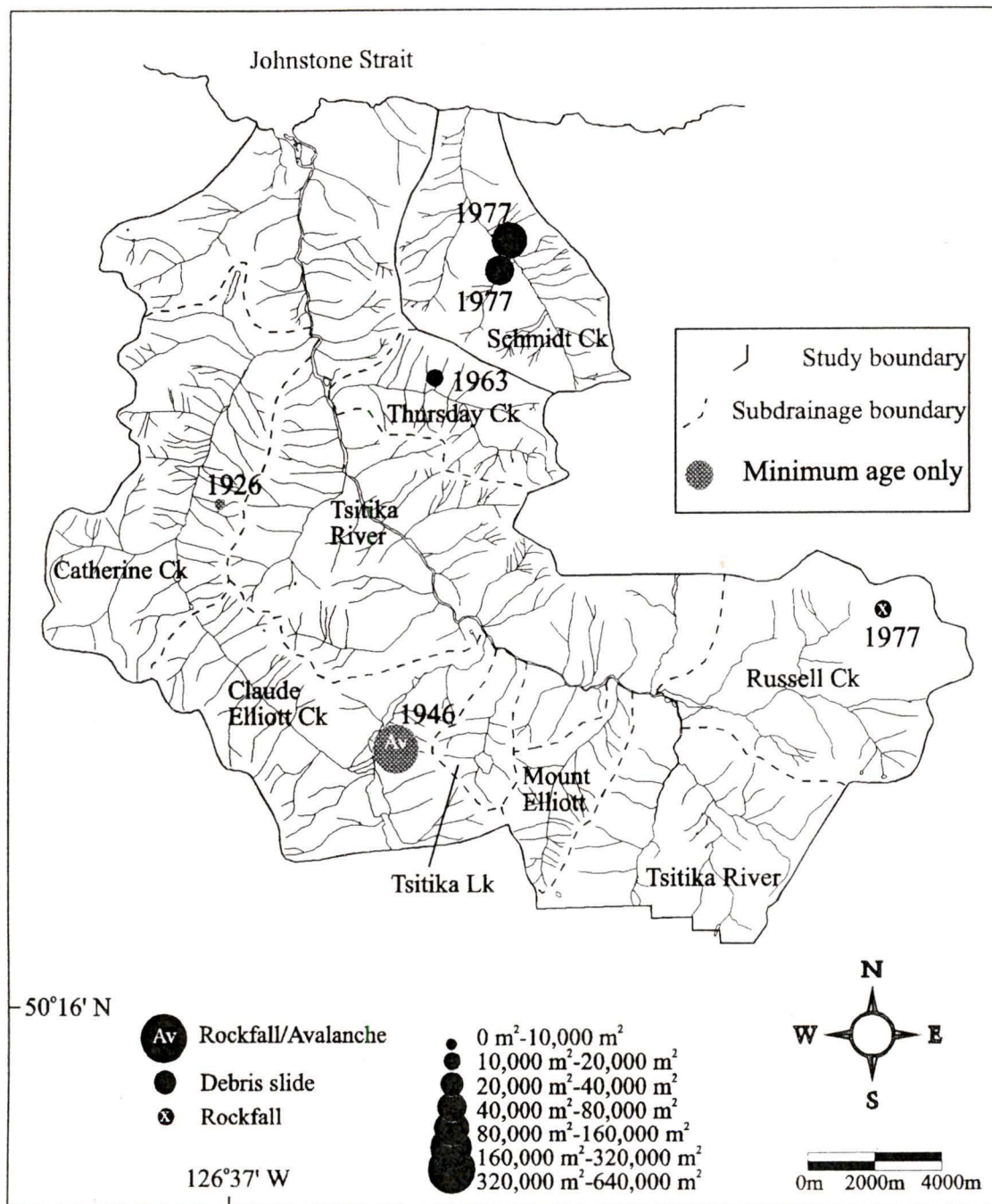

Figure 5.23: Landslides that may have been coincident to storms with return intervals from 1:25 - 1:50 years. Date of storm is beside landslide.

Tsitika indicating that there may be local variations between Alert Bay and the Tsitika study area. Two of the three debris slides were recorded as occurring during that storm (TR05 and TR07).

### **5.10.2 Landslide Dates and Seismic Events**

The years of occurrence for earthquakes that resulted in intensities great enough to potentially trigger landslides in the Tsitika study area are: 1946, 1918, 1700, 1300 +/-130. The earthquake in 1918 resulted in intensities of V in the study area, the lowest recognized threshold for causing debris slides, making the occurrence of a landslide an unlikely event (Keefer, 1984). No landslides were recorded that year. The earthquake in 1946 resulted in modified Mercalli intensities of VI in the study area. The rockfall/avalanche CL01 occurred the same year. The other rockfall/avalanche (TL02) was observed to have two minimum age dates of 1744 and 1385. There is a possibility that the events may have failed during the great earthquakes of 1700, and 1300 (+/-130). Figure 5.24 shows the distribution and areas of landslides roughly coincident to seismic activity.

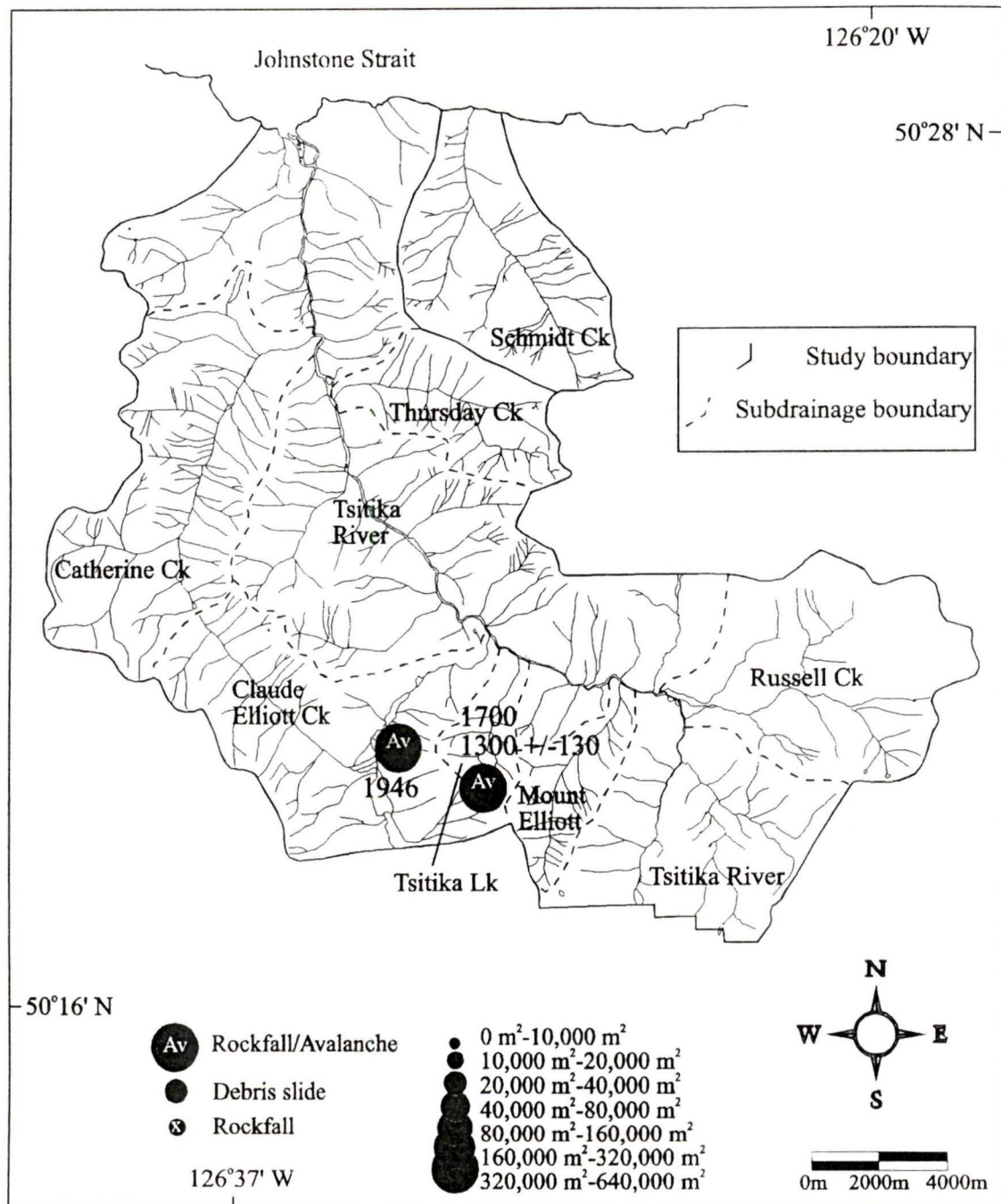

Figure 5.24: Landslides that may have been coincident to seismic events. Landslides based on minimum ages. Dates of seismic activity are beside landslide.

## 6.0 DISCUSSION

Three types of mass movements were documented in this study: debris slides, rockfalls, and rockfall/avalanches. The discussion begins with the physical characteristics and features that influenced the occurrence of landslides. The Tsitika study area is then discussed according to subdrainage. Landslide dates are examined, followed by the correlation of landslides with precipitation events, and landslides with seismic events.

### 6.1 Debris Slides

Debris slides are the most common of the three landslide types noted in the study area. The majority of debris slides occurred over volcanic rock (77%), in morainal deposits (58%), or some combination of both. Debris slides initiate typically below the tree-line, at elevations below 1,000 m, on slopes whose gradients generally range from mid 30° to low 40°.

There is a strong relationship between the occurrence of debris slides in this study and bedrock dip. The Karmutsen Formation flow beds dip primarily southwest and west. This describes the direction of 70% (14) of the debris slide sites in the Karmutsen volcanics. Rollerson (1996, personal communication) suggests that there is a perception that the Karmutsen Volcanics are roughly homogenous, and that bedding is not recorded as important information on landslides in this material. Clearly however, the flow bed dip direction is very significant with respect to slope stability. In contrast there appears to be

no dominant landslide direction overlying the Island Intrusives. Increased instability is likely on dip slopes due to a uniform impermeable surface of relatively low friction, between the bedding plane of the bedrock and the surficial material. Howes (1981a) found similar results in a regional study of northern Vancouver Island. He states that 67% of slumps and rockslides occurring in volcanics on northern Vancouver Island (Bonanza Formation and Karmutsen Formation) are on down-slope dipping beds.

Some of the debris slides in till appears to occur primarily on the weathered sediment - intact sediment interface. In such cases it seems unlikely that bedrock dip would be significant. Morainal deposits, however, are typically thinner in the initiation zones, and thickest at the base of the slope (thus the concentration of morainal blankets in lower slopes, Figure 2.6). Debris slides usually initiate on the sediment - bedrock interface, and this in turn controls the direction of movement.

The large number of debris slides underlain by Karmutsen Volcanics is not completely accounted for by dip slopes. Six debris slides occur on scarp slopes (dipping into the hill), which are expected to cause an increase in friction and therefore a decrease in number of debris slides. However, the volcanics may be subject to the weathering and alteration of the original rock into softer mineral types. This could result in a decrease in support strength for the overburden material.

The erosion and weathering of volcanics in the study area produces a finer matrix of sediment than the erosion and weathering of intrusive rock (see section 2.1.2). It is expected that unconsolidated, finer sands and silts are less stable on a steep gradient than coarser material, due to a decrease in the open pore framework of these soils (Ritter,

1978). This is especially true during periods of increased pore pressure caused by precipitation. Since both colluvium and morainal sediment types in the study area are closely associated with the underlying geology, it is likely that the surficial material overlying the Karmutsen Volcanics is inherently less stable on steep slopes and under wet conditions.

Debris slides initiate on steep slopes, usually below the tree-line. Slopes with gradients below  $30^\circ$  are not generally associated with the initiation of debris slides in the study area. Slopes greater than  $45^\circ$  are generally too steep for the accumulation of unconsolidated sediment, and therefore are also not generally associated with debris slides. Deep sediments, both morainal and colluvial, are more common on lower slopes with relatively low gradients. Debris slides are most likely to start in the shallow  $<1$  m upper-slope sediments, overlying bedrock. Observed gradients of debris slides are in agreement with Howes (1981a). The concentration of initial elevations of debris slides in the study area reflects the overall slope profile of the landscape, where gradients between  $30^\circ$  and  $45^\circ$  are most common between 750 and 1,050 m. Slopes above the tree-line, and slopes greater than  $45^\circ$  are dominated by the initiation of snow avalanches and active rockfall as evidenced by snow catchment areas, snow avalanche tracks, and talus cones. The active process of snow avalanching also transports debris down-slope and may hide evidence of minor debris sliding that can also occur at these sites.

Debris slide areas vary considerably throughout the area. The factors that influence debris slide area are local topography (elevation, steepness of slopes, drainage pattern), uniformity of slope, initiation height, and whether or not the debris slide was

interrupted by a stream. For example, large areas are favored by uniform steep slopes, a high initiation elevation, and a long runout distance before intersecting a stream. There is considerable variation in debris slide area due to topographic, and morphological variations between different subdrainages. Overall, the type of bedrock and surficial geology do not appear to be critical factors in determining the area of debris slides.

The volume of a landslide is primarily driven by its areal extent. Five debris slides had area to volume ratios less than or equal to 1:1. These debris slides all occurred over morainal sediments >1 m which in turn contributed to the depth of the landslide. Morainal deposits were in fact critical to the occurrence and strongly influenced the volume on almost 60% of debris slides in the study.

Seventy one percent (22) of debris slides deposited sediment into a stream channel. High order streams (three and greater) provide spawning grounds and transportation corridors for fish, and are considered a high value resource in British Columbia (British Columbia Ministry of Forests, 1995d). In addition, high order streams develop complex ecosystems and riparian zones. Riparian zones contain many of the highest value resources in British Columbia other than timber, including critical habitat and travel corridors for wildlife (British Columbia Ministry of Forests, 1995d). A landslide may impact a stream by adding sediment to the bedload, potentially changing temperature and biomass characteristics, by blocking and/or relocating a stream, by providing barriers to fish by way of log jams and sediment, or by scouring out streams entirely (Hogan and Schwab, 1991b). In addition landslides may severely alter sections of the riparian zone. Hogan and Schwab (1991b) estimate recovery times for salmon bearing streams following

landslide debris input to be about 30 years. In general, a landslide has greater potential impact on a higher order stream than a lower order stream. Debris slides have contributed a total of about 122,400 m<sup>3</sup> of sediment to third order channel segments in Schmidt Creek, Thursday Creek, and Catherine Creek. Debris slides have impacted streams more frequently than either rockfalls or rockfall/avalanches.

## 6.2 Rockfalls

Three rockfalls were described in detail in this study. They all detached from cliffs above steep slopes and had very short (<500 m) runouts. It is unrealistic to make generalizations about rockfalls based on the distribution of only three events, however, some observations are discussed here.

Two rockfalls occurred in Karmutsen Volcanics, and one in Island Intrusives. While it is not statistically valid to comment on probability of occurrence with so few samples, it is informative to note that Howes (1981a) observed a higher frequency of rockfalls in the Karmutsen Volcanics versus the Island Intrusives on a regional scale. The rockfalls occurred in bedrock and were not associated with surficial deposits. Both rockfalls in Karmutsen Volcanics occurred on dip slopes. Dip slopes may have contributed to the events by decreasing support to fractured bedrock. The rockfall in Island Intrusives revealed a smooth flat cliff face, inferred to be a result of bedrock jointing or fracture. Major faults in the study area exist primarily beneath the riverbeds and are not directly associated with any landslides. Rockfall gradients are steep,

beginning in vertical or nearly vertical cliffs, and terminating at slopes as steep as 45°.

Rockfalls occur at upper elevations (1,000 m +), where the slope profile is generally at its steepest.

The three rockfalls are very similar in size (10,000 m<sup>2</sup> - 13,700 m<sup>2</sup>) and do not exhibit the wide range of areas seen in debris slides. This could however, be due to the fewer numbers of rockfalls recorded. Similarly the volumes of rockfalls are low (<10,000 m<sup>3</sup>). Two of the rockfalls deposited sediment into first and second order stream channel segments respectively. These rockfalls may contribute sediment to channelized debris flows, increasing their potential impact.

### **6.3 Rockfall/avalanche**

Two rockfall/avalanches occur in the study area. It is again difficult to make generalizations based on so few a number, but the observations are discussed below.

Both rockfall/avalanches occur in Island Intrusives. Both Island Intrusives and Karmutsen Volcanics are heavily fractured and jointed, an observation also noted by Muller *et al.* (1974) and Howes (1981a). It is doubtful that the occurrence of these two landslides in Island Intrusives is in itself significant, as similar landslides in other areas have been documented in both the Intrusives, and in Karmutsen Volcanics by Howes (1981a) and VanDine and Evans (1992). In fact, both publications suggest that large landslides occur more frequently in Karmutsen Volcanics. Unfortunately no comparisons are made between the number of large landslides and the total area each formation occupies.

Gradients are steep in the upper slope portion of the profile, and very flat ( $5^{\circ}$  -  $11^{\circ}$ ) at the base. Runouts of both rockfall/avalanches are 1.5 and 1.8 km respectively, and the two landslides are about  $500,000 \text{ m}^2$  in size. The greatest difference between them is that one (CL01) occurs on a glacially oversteepened wall of a broad valley, and the other (TL02) begins at the head of a smaller and narrower hanging valley.

Rockfall/avalanches, because of their size, result in a skewed picture of landslide activity in the study area, when looking at total impacts. Rockfall/avalanches are comparatively infrequent events that have immediate and permanent impact on the landscape. They belong as part of the overall picture of mass movement within the study area, but are nevertheless relatively unique. Both rockfall/avalanches are large, and both have contributed at least  $100,000 \text{ m}^3$  of sediment to a stream channel segment.

CL01 has resulted in the greatest single impact of any landslide in the study area. This rockfall/avalanche blocked and relocated a major (fourth order) channel by forming a landslide dam, to the extent that the change is clearly evident on regional small scale maps (British Columbia, Lands and Forests, Northerly Portion of Vancouver Island, Map 2C, 1929 and 1948). The amount of sediment that entered the stream is in the order of  $250,000 \text{ m}^3$  (approximately half the total volume). Clearly this would have a major impact on the stream and riparian zone, as discussed in section 6.1.

TL02 deposited about  $125,000 \text{ m}^3$  into a second order channel segment. A lake at the base of this rockfall/avalanche acted as a buffer to sediment, and therefore reduced the impact to the watershed. Nevertheless, approximately  $400,000 \text{ km}^2$  of land was disturbed,

and has not fully recovered 600 years later (it failed initially prior to 1385). Evidently both rockfall/avalanches have had substantial physical impact on the Tsitika study area.

## **6.4 Subdrainages**

### **6.4.1 Schmidt Creek**

Schmidt Creek is a relatively small basin, bounded on all sides by high peaks, except for the mouth of the stream that flows into the ocean. The valley has been glacially oversteepened, and is primarily till covered, except for its uppermost slopes. The till varies in thickness from a thin veneer on upper-slopes, to a thick blanket on lower-slopes.

Nine events occurred at five sites in Schmidt Creek. SC02 and SC04, both occurred more than once. All of the landslides were debris slides. There are considerably more landslides per unit area in Schmidt Creek than occur in the study area as a whole.

In the Tsitika study area, morainal deposits, which cover approximately 27% of the ground, occur to a large degree on glacially subdued topography at lower gradients. In some subdrainages however, specifically in Schmidt Creek and Thursday Creek, more till has accumulated on steeper slopes. The weathering of this till in addition to the uniform slopes in Schmidt Creek contributes to the evident increased instability on these slopes. In addition, the inferred dip of the bedrock is probably critical to SC01, SC04, and SC05. All three landslides initiate at high elevations, and have a section of exposed bedrock in their initiation zone.

Schmidt Creek is steep and flows a relatively short distance to the ocean.

Sediment that enters a main channel segment is likely to be transported through the drainage basin and may impact the shoreline environment as well. This impact may include the aggradation of coarse materials onto Orca rubbing beaches. It is not currently known what the significance of such an impact would be.

#### **6.4.2 Thursday Creek**

Thursday Creek is a steep narrow tributary to Tsitika River. Like Schmidt Creek, it contains a high number of landslides relative to its area, more so in fact than any other subdrainage. The landslides are all debris slides, and two of the six landslides have had recurring events. The total number of recorded events are eight.

All the landslides are located on the south facing slope. All are similar in size, gradient and initiation elevation. Tree patterns on air photographs are thinner on this slope suggesting less stable growing conditions than adjacent areas, and once again morainal deposits are found on moderately steep slopes. The overall stability of surficial material on the slope on which these debris slides occur is low. This is the portion of the slope covered by till, that begins at a slope break at 600 m, and rises with the main creek to about 950 m. Further, the bedrock dips down-slope here, resulting in lower strengths in the initiation zone. The absence of landslides on the opposing slope is probably due to increased friction of beds dipping into the hill, and a lack of overlying till.

Thursday Creek has been severely disturbed by landslide sediments deposited in its channel. Log jams and islands were noted in the main stream, into which all landslides in this drainage directly deposit. There is potential for at least two of the debris slides (TH01, TH04) to slide again, based on a portion of unconsolidated sediment that accumulated on the slope but remains only marginally stable. Considering the past instability of the south facing slope overall, new debris slides should be expected in Thursday Creek.

### **6.4.3 Tsitika River**

The Tsitika River subdrainage comprises 43% of the total study area, and is the main repository for the other subdrainages (except for Schmidt Creek which flows directly into the ocean). The Tsitika River subdrainage contains 26% (8) of the landslides over 43% of the total area in the study. At least three factors account for the fewer numbers of landslides. The first is that about half the drainage is underlain by Island Intrusives which have fewer landslides in the study area than Karmutsen Volcanics (Figure 5.3). The second is that a portion of the basin, at the elbow of the river has been topographically subdued by the last glaciation. This has resulted in deep morainal deposits (>1 m), however, there are fewer steep slopes. In addition, slopes that might otherwise be expected to be less stable are underlain by bedrock dipping into or across the slope. This results in higher shear strengths relative to downslope dipping bedrock.

Strong variations in topography are clearly indicated by the widest range of elevations and gradients at which landslides occurred in the study area. Landslide elevations reflect the wide range of elevations present in the subdrainage itself. However, the range of landslide areas is similar to ranges everywhere except Thursday Creek, Tsitika Lake and Claude Elliott Creek, including ranges determined by geology. Tsitika Lake and Claude Elliott Creek contained too few events to provide any statistical basis for comparison. In addition, rockfall/avalanches occurred in both these subdrainages, greatly disrupting the area statistics. Landslide areas then are typical despite the varied conditions.

The direct contribution of landslide debris to high order stream channel segments in the Tsitika River subdrainage is low relative to other subdrainages such as Thursday Creek, Schmidt Creek or Claude Elliott Creek. However, debris slides and rockfalls may deposit sediment in low order streams. That sediment may be incorporated in channelized debris flows, increasing the potential to carry sediment farther downstream.

#### **6.4.4 Catherine Creek**

Catherine Creek contains landslides in about the same proportion to the total, as its area (19%, or six of the landslides for approximately 14% of the total area). The landslides are fairly typical in size and gradient, but have lower than normal initial elevations and a wider than expected range of azimuth directions. Initial elevations are lower because of the nearness to the mouth of the Tsitika River (sea level), and the

relatively shallow initial gradient of Catherine Creek (relative to Thursday and Schmidt creeks). The variation in landslide directions is accounted for to a large degree by three landslides occurring in close proximity to one another. CC01, CC02, and CC04 all occur in weathered till and occur very close together. The fact that a relatively small area generated three distinct landslides suggests that the overall deposit may be particularly unstable, or that the occurrence of one debris slide (CC02) altered the drainage pattern, or removed support such that the other two events were more likely.

Two debris slides contributed significant quantities of debris to Catherine Creek. CC06 is a large debris slide, which contributed almost 40,000 m<sup>3</sup> of sediment to the stream. CC04 has contributed 10,000 m<sup>3</sup> of sediment. Both debris slides blocked and caused lasting changes to a high order stream. Hogan and Schwab (1991b) estimated recovery times of blocked and altered streams in the Pacific Northwest to be on the order of 30 or more years. That estimate is likely too low for CC06. These debris slides have equivalent analogs in the other subdrainages. It is once again probable that volcanic flow beds dipping down-slope in the initiation zone of CC06 contributed to its occurrence.

#### **6.4.5 Claude Elliott Creek**

Claude Elliott Creek is the third largest subdrainage delineated in the study area (Table 5.1, Figure 5.1). Only one landslide, a rockfall/avalanche, was noted in this basin. This is few relative to the rest of the study area, and is a probable result of numerous factors:

Close to two thirds of the basin is underlain by Island Intrusives, and the remaining slopes (those underlain by Karmutsen Volcanics) are at right angles to dip (Figure 5.3). Given the correlation between dip direction and debris slides, and lack of debris slides over Island Intrusives observed previously, one would expect fewer debris slides in this subdrainage.

The north-east facing side of the drainage culminates in a ridge with peaks that reach above the tree-line, and large snow catchments. Less solar radiation allows for deeper accumulation of snow, and as a result, this area is frequently dominated by snow avalanching. The high peaks are also subject to active rockfall.

In addition, while the valley floor is broad and flat and covered in a morainal blanket (>1 m), the west facing slope is almost devoid of any fine sediments. The colluvium overlying the bedrock is primarily formed of blocks and boulders, not conducive to debris slides. The colluvium is inferred to be a result of past rockfall activity, including the falling of large individual boulders. Some of these rockfalls have resulted in massive boulders being transported into Claude Elliott Creek. The dating of these boulders is beyond the scope of this project.

The rockfall/avalanche CL01 is, however, the largest single event in the Tsitika study area, and is more significant for the fact that it resulted in a landslide dam that blocked a fourth order channel segment. It was discussed previously in section 6.3.

#### **6.4.6 Tsitika Lake**

Tsitika Lake is the smallest subdrainage but contains two landslides; a debris slide (TL01) and a rockfall/avalanche (TL02). Generalizations stating that Tsitika Lake is particularly less stable than adjacent sub-basins, or that it is more prone to rockfall/avalanches, would be inaccurate given the sample size. However, the rockfall/avalanche does result in a very high overall impact on this sub-basin.

The rockfall/avalanche fills the floor of a hanging valley and terminates at a lake. The lake behaves as a buffer and prevents the sediment from being incorporated into the rest of the watershed. The large size of the landslide however, has had a lasting impact on the hanging valley and the lake, which show evidence of its initial occurrence approximately 600 years ago.

The debris slide occurs primarily in weathered till, below the hanging valley. This debris slide has been triggered more than once, and is inferred to be the result of the repeated weathering of exposed till. The importance of weathering is also noted regionally by Howes (1981a).

#### **6.4.7 Mount Elliott**

The Mount Elliott subdrainage is only marginally larger than the Tsitika Lake subdrainage. It is a narrow valley characterized by a number of peaks connected by a ridge. The valley is small and steep, providing its own shade, and therefore accumulating

snow which may last well into summer. As a result, snow avalanching is the dominant mass wasting process in this basin, and is common throughout. Rockfall also occurs as an active process on most of the exposed steep upper slopes. Discrete landslides were not noted in this basin.

#### **6.4.8 Russell Creek**

The Russell Creek subdrainage contains an average number of landslides in proportion to its size. Landslides observed are two debris slides (RC01 and RC03) and a rockfall (RC02) on steep walls of a glacially broadened valley.

Active rockfall and talus buildup occur off exposed peaks to the south and east, and snow avalanching is also prominent where large catchment areas are available. The lower part of the drainage, along Russell Creek has been heavily eroded by glaciers, resulting in a broad moraine covered valley floor and lower slopes.

#### **6.5 Landslide Dates**

Forty three landslide dates across 31 sites were recorded in the Tsitika study area. Landslide dates were primarily derived using dendrochronology, air photographs, and 1:50,000 terrain maps. Landslide records at MacMillan Bloedel provided dates for TR02, TR05, and TR07, which all occurred in 1990.

The following landslides; SC03, SC05, TR06, TH02, TH05 and TH06 are known only to be older than the earliest air photographs, taken in 1953. The accuracy of landslide dates is highest for any landslide occurring since 1970. Almost all landslides occurred in the last 100 years. This should not imply that landslides did not occur prior to 100 years ago, but earlier landslides have been over-ridden by the more recent events, or they are no longer discernible from the surrounding landscape.

A greater number of landslides were recorded in the last 50 years, than the previous 50. A number of reasons could explain this. One reason is simply a recording error that increases with time. However, increased precipitation may also be the cause. Ninety percent of storms at Alert Bay with return periods of 1:10-1:25 were recorded since 1945. Sixty seven percent of storms with 1:25-1:50 returns were also recorded in that same period, as was the only storm with a return period less than 1:50. Some of the largest storms were also recorded during the mid-seventies. The largest concentration of landslides occurred over this same period.

At least six debris slides (SC02, SC04, TH01, TH03, TR07 and TL01) occurred more than once. All debris slides, except TR07, which were recorded as repeat events, occurred in morainal deposits on steep slopes. The two subdrainages most heavily affected by recurring events are Schmidt Creek and Thursday Creek. All recurring landslides reached a stream. In both subdrainages the sediment was deposited into third order streams. Both contain debris and log jams, and probably suffered increased erosion and gravel bar aggradation as a result. It is difficult to say what the volumes of past

events were, but certainly the frequency of impact on relatively small areas is greatest in these two subdrainages.

TR07 was recorded as having occurred at least five times. Those dates were derived using dendrochronology, air photographs, and MacMillan Bloedel records. TR07 occurred in colluvial deposits on the steep upper slopes of a tributary to the Tsitika River. These upper slopes remain unstable, and devoid of any vegetation other than small shrubs. The debris slide provides large amounts of sediment to the tributary, which becomes incorporated as a channelized debris flow and which in turn deposits sediment on a fan only slightly upslope and perpendicular to the Tsitika River. These channelized debris flows may or may not have occurred simultaneously to the debris slides up-slope. The dates for TR07 were nevertheless taken from the fan, and represent the discharge of accumulated sediment in the channel. Based on the continued bare slopes, it is likely that TR07 experiences small failures on its exposed surface with even more regularity than recorded by the dates; and that it will continue to do so until all the colluvium has been removed.

TL02 is a rockfall/avalanche, and is also recorded as occurring twice. TL02 occurs in bedrock, and bedrock jointing and fracturing are inferred to contribute to both events. It is relatively unique in the study not only because of its type and size, but also in that it is the only landslide recorded to have occurred before 1744 and 1385. Both years are represent a minimum age when the rockfall/avalanche may have occurred. Further dendrochronology work is needed to better date these two events.

### 6.5.1 Correlation of Dates with Precipitation

Precipitation over a period of time may saturate the soil, causing an increase in pore pressure and a decrease in slope strength. Precipitation has been shown to be a trigger mechanism for landslides by numerous authors (Church and Miles, 1987, Hogan and Schwab, 1990, 1991a, Fannin, 1991, Bovis and Millard, 1992, Chatterton, 1994, Swanston and Howes, 1994b, Septer and Schwab, 1995, Wieczorek, 1996). A tentative relationship between landslides and precipitation has previously been observed, whereby the number of landslides has increased with increased intense precipitation in the last 50 years. Anecdotal information at MacMillan Bloedel recalls that TR05, and TR07 failed during a large storm in November, 1990. Further analyses of landslide dates suggest a possible correlation with storm events.

Six debris slides were recorded for the year 1975. This is the greatest number of events recorded in the study area for a single year. It is also the year of the only storm whose return interval at Alert Bay is less than 1:50 years. Landslides also occurred during four of the six years that were recorded as having storms with return periods between 1:25-1:50 years. The four years are 1926, 1946, 1963, and 1977. All landslides were debris slides except for CL01, a rockfall/avalanche that occurred in 1946. CL01 will be discussed further in the next sub-section. Three of the seven years with storm return intervals from 1:10-1:25 had landslides occur the same year.

Local orographic effects affect precipitation conditions. A large storm in the Tsitika was noted by MacMillan Bloedel employees in 1990, but did not register at Alert

Bay as having a return period less than 1:10 years. Nevertheless, three debris slides in the study area occurred the same year, two of which were recorded as occurring during that storm (TR05 and TR07).

It is suggested that these large precipitation events are the triggering mechanisms for the landslides that occur coincident to them. It is further reasonable to project that a future storm, whose return interval is between 10 - 25 years, is likely to trigger at least one landslide in the study area. A future storm with a return of greater than 50 years stands an excellent chance of triggering more than one landslide in the study area.

#### **6.5.2 Seismic activity and dates of landslides**

Only two recorded seismic events (1918 and 1946), occurring in the past 100 years resulted in intensities in the study area, strong enough to result in landsliding.

The event in 1918 resulted in intensities of V in the study area, however, no landslides were recorded in 1918.

The 1946 magnitude 7.3 Vancouver Island earthquake has been related to landslides on Vancouver Island by Rogers and Hasegawa (1978), Mathews (1979), Rogers (1980), Evans (1989a, 1989b), and VanDine and Evans (1992). It resulted in intensities of VI I in the study area. These intensities are considered sufficient to trigger a landslide. The rockfall/avalanche CL01 occurred that same year. In addition to seismic activity in 1946 however, there was also a storm with a return interval between 1:25-1:50. While there is occasionally some controversy regarding the causes of rockfall/avalanches

(Cruden, 1977, Wetmiller and Evans, 1989, and Weichert *et al.* 1994), most rockfall/avalanches are historically associated with seismic activity (Keefer, 1981, 1984, 1989, Cary *et al.*, 1992, Jacoby *et al.*, 1992, VanDine and Evans, 1992, Carpenter and Easterbrook, 1993, Wieczorek, 1996, and others). A rockfall/avalanche fails in bedrock as opposed to surficial material and typically requires a formidable trigger mechanism to reduce the rock strength sufficiently to initiate failure. The 1946 earthquake is the most likely trigger mechanism for CL01.

It is expected that seismic activity would be required to trigger the rockfall/avalanche TL02 as well. Interestingly, the two minimum age dates (1744 and 1385) derived for this event are crudely coincident to the dates of two past great earthquakes (1700, and 1300 +/- 130). Great earthquakes such as these are expected to result in rockfall/avalanches and other large landslides over a region of considerable distance (Adams, 1990, Atwater, 1992, Cary *et al.*, 1992, Jacoby *et al.*, 1992, and others). While far from conclusive, it is certainly possible that these earthquakes resulted in the rockfall/avalanches at TL02. A more intensive dendrochronological study on TL02 may provide collaborative data for both seismic events.

## 7.0 CONCLUSIONS AND RECOMMENDATIONS

The steep, mountainous areas of coastal British Columbia are subject to landsliding. Landslides modify slope morphology, and are considered a serious hazard in these areas. Understanding the physical characteristics of natural landslides is important in assessing the settings and conditions under which slope instability may occur. This knowledge in turn, provides useful data for land management.

Thirty one natural landslide sites and 43 landsliding events were documented in the Tsitika River and Schmidt Creek watersheds on Vancouver Island. These watersheds were chosen as a natural laboratory, and it is expected that the results will be applicable to similar locations on both Vancouver Island and coastal mainland British Columbia. The 365 km<sup>2</sup> study area was divided into eight subdrainages, and landslides were analyzed and compared to one another.

The 31 landslide sites examined included debris slides, rockfalls, and rockfall avalanches. They ranged in size from 7,000 to 600,000 m<sup>2</sup>, and in volume from 3,200 to 500,000 m<sup>3</sup>. Approximately 71% of landslide sites deposited sediment directly into a stream channel.

The landslides were distributed across two bedrock types; a granitic intrusive body (Island Intrusives) and layered volcanics (Karmutsen Volcanics). Debris slides occurred primarily over the Karmutsen Volcanics, and on dip slopes. Debris slides, which accounted for 84% of the landslide types, were also strongly associated with morainal deposits, typically failing in the initiation zone at the till/bedrock interface. Smooth, till

covered, uniform slopes in the study area, are likely to be unstable and prone to debris slides. Clusters of debris slides or repeat events are more likely to occur in moraine than in colluvium.

Rockfall, excluding active rockfalls (talus buildup), accounted for three of the landslides in the study area. They occurred on steep bluffs as a result of jointed or fractured rock. They were not associated with morainal deposits, nor did they directly impact stream channels.

Rockfall/avalanches accounted for only two of the landslides in the study area, but accounted for approximately 63% (1,000,000 m<sup>3</sup>) of the total volume. Rockfall avalanches run long distances over low slopes and have blocked and altered streams in the study area.

Debris slides are the most frequent contributor of sediment to streams of the landslides examined in this study. Two drainages where this is particularly evident are Schmidt Creek and Thursday Creek which have morainal deposits overlying long uniform slopes, terminating in steep stream channels.

Forty three events at 31 sites were dated using dendrochronology, air photographs, maps and recorded information from MacMillan Bloedel. The resultant ages range from as young as 1990 to likely older than 1386, however, most were less than 100 years old.

Precipitation and seismic data were analyzed for approximately the last 100 years, and where possible, the year of severe events correlated to the year of landslide occurrence. A reasonable correlation occurs between severe storms and landslides. Six

debris slides occurred the same year as a storm with a return interval less than 1:50. Four of six storms with return intervals between 1:25-1:50 occurred during the same year as landslides in the study, however, at least one of them, the rockfall/avalanche CL01, which occurred in 1946 is unlikely to be related. Three of seven storms with return intervals between 1:10-1:25 years occurred during the same year as a landslide. In addition, two severe storms in 1990 are known to have occurred at the same time as a debris slide (TR05 and TR07). Two other debris slides occurred that same year.

An attempt was made to correlate seismic events with the occurrence of landslides. The 1946 earthquake is a reasonable trigger mechanism for a rockfall/avalanche such as CL01 or TL02. CL01 occurred that same year. Two great earthquakes, 1700, and 1300 +/- 130, may have been the cause of the rockfall/avalanches that occurred at TL02. No debris slides or rockfalls in the study were found to be related to earthquakes.

This study has attempted to characterize and date landslides in the Tsitika River and Schmidt Creek watersheds, in an effort to better understand and document their occurrences. The results are expected to be applicable to other areas of similar biogeoclimatic characteristics that occur on both Vancouver Island and on coastal mainland British Columbia.

Recommendations for further work include:

- ◇ Channelized debris flows occur more frequently than debris slides, rockfalls and rockfall/avalanches, but typically include less sediment. A comparison would be useful, between the contribution of debris slides, rockfalls and rockfall/avalanches, and

the contribution of channelized debris flows, to sediment in major channels in the study area.

- ◇ A comparison of landslide recovery rates, based on material type, depth of landslide, and size of event would further contribute to the understanding of the various impacts of an event over time.
- ◇ A comparison of landslide recovery rates in the study area to landslide recovery rates in clear-cut forests in similar biogeoclimatic zones would help to determine the impact of clear-cutting on slope recovery.
- ◇ Landslides have an important impact on the stream environment. An evaluation of stream recovery rates from landslide debris that has entered and altered the morphology of, or blocked a channel would be useful to assess the size of that impact.
- ◇ An overall hazard assessment of naturally occurring landslides, and its application to other biogeoclimatically similar areas could be developed from data such as this, and used to make sound land management decisions.

## 8.0 REFERENCES

- Adams, J. 1990. Paleoseismicity of the Cascadia subduction zone: Evidence from turbidites off the Oregon-Washington margin. *Tectonics*, **9**: 569-583.
- Alard, S. S. 1980. Effects of mass movement on tree growth: An example from the Manti landslide, Utah. Abstracts with programs, south-central section of the Geological Society of America, 14th Annual Meeting, **12**: 265.
- Alexander, D., and Formichi, R. 1993. Tectonic causes of landslides. *Earth Surface Processes and Landforms*, **18**: 311-338.
- Atwater, B. F. 1987. Evidence for great Holocene earthquakes along the outer coast of Washington. *Science*, **236**: 942-944.
- Atwater, B. F. 1992. Geological evidence for earthquakes during the past 2000 years along the Copalis River, southern coastal Washington. *Journal of Geophysical Research*, **97**: 1901-1919.
- Begin, C., and Filion, L. 1985. Analyse dendrochronologique d'un glissement de terrain de la region du Lac à L'Eau Claire (Quebec Nordique). *Canadian Journal of Earth Sciences*, **22**: 175-182.
- Begin, C., and Filion, L. 1988. Age of landslides along the Grandes Rivière de la Baleine estuary, eastern coast of Hudson Bay, Quebec (Canada). *Boreas*, **17**: 289-299.
- Bobrowsky, P. T., and Meldrum, D. 1994. Preliminary drift exploration studies, northern Vancouver Island (92L/6, 92L/11). *In* British Columbia Geological Survey Branch, Geological Fieldwork 1993, Paper, 1994-1, p. 87-99.
- Bolt, B. A. 1978. *Earthquakes, a primer*. W. H. Freeman and Company, 241 p.
- Boore, D. M., Joyner, W. B., and Thomas, E. 1993. The estimation of response spectra and peak acceleration from western North American earthquakes: An interim report. United States Geological Survey, Open File 93-509.
- Boore, D. M., Joyner, W. B., and Thomas, E. 1994. The estimation of response spectra and peak acceleration from western North American earthquakes: An interim report, Part II. United States Geological Survey, Open File 94-127.
- Bovis, M. J., and Millard, T. H. 1992. Precipitation thresholds for debris flow initiation in the southern Coast Mountains of British Columbia. *In* Geotechnique and Natural Hazards, Proceedings of the 1992 Symposium, p. 309.

- British Columbia Department of Lands and Forests 1929. The northerly portion of Vancouver Island, Map 2C (1:253,440 scale map).
- British Columbia Department of Lands and Forests 1948. The northerly portion of Vancouver Island, Map 2C (1:253,440 scale map).
- British Columbia Ministry of Environment 1978. Tsitika River watershed, terrain classification (1:31,680 scale map). Resource Analysis Branch, British Columbia Ministry of Environment.
- British Columbia Ministry of Forests 1990. Richmond outlines plans for Tsitika/Robson Bight. British Columbia Ministry of Forests news release, 3 p.
- British Columbia Ministry of Forests 1992. Biogeoclimatic zones of British Columbia (1:7,500,000 scale map). British Columbia Ministry of Forests Research Branch, Victoria British Columbia.
- British Columbia Ministry of Forests 1995a. Gully assessment procedure guidebook. Government of British Columbia, Victoria, British Columbia.
- British Columbia Ministry of Forests 1995b. Mapping and assessing terrain stability guidebook. Government of British Columbia, Victoria, British Columbia.
- British Columbia Ministry of Forests 1995c. Coastal watershed assessment procedure guidebook. Government of British Columbia, Victoria, British Columbia.
- British Columbia Ministry of Forests 1995d. Riparian management area guidebook. Government of British Columbia, Victoria British Columbia.
- Brown, W. M., Cruden, D. M., and Denison, J. S. 1992a. The directory of the world landslide inventory. United States Geological Survey, Open File Report, 92-0427-A, 239 p.
- Brown, W. M., Cruden, D. M., and Denison, J. S. 1992b. The directory of the world landslide inventory. United States Geological Survey, Open File Report, 92-0427-B, 21 p.
- Buchanan, P., and Savigny, K. W. 1990. Factors controlling debris avalanche initiation. Canadian Geotechnical Journal, **27**: 659-675.
- Carlisle, D. 1972. Late Paleozoic to mid-Triassic sedimentary-volcanic sequence on northeastern Vancouver Island. *In* Report of Activities. Geological Survey of Canada, Paper 72-1, Part B, p. 24-30.

- Carpenter, M. R., and Easterbrook, D. J. 1993. The Church Mountain sturzstrom (mega-landslide), Glacier, Washington. Abstracts with Programs, Geological Society of America, **25**: 18.
- Cary, C. M., Easterbrook, D. J., and Carpenter, M. R. 1992. Post glacial mega-landslides in the North Cascades near Mt. Baker, Washington. Abstracts with Programs, Geological Society of America, **24**: 13.
- Cassidy, J. F., Ellis, R. M., and Rogers, G. C. 1988. The 1918 and 1957 Vancouver Island earthquakes. Bulletin of the Seismological Society of America, **78**: 617-635.
- Chatterton, A. N. 1994. Operational shutdown guidelines for Vancouver Island and the Lower Mainland. British Columbia Ministry of Forests, Working Committee on Precipitation Related Operational Shutdown Guidelines for Coastal Regions.
- Chatwin, S. C., and Rollerson, T. P. 1984. Landslide study, TFL 39, block 6. Landuse Planning and Advisory Team, Woodland Services Division, MacMillan Bloedel Limited.
- Chatwin, S. C., and Smith, R. B. 1992. Reducing soil erosion associated with forestry operations through intergrated research: An example from coastal British Columbia, Canada. *In* Erosion, Debris Flows and Environment in Mountain Regions: Proceedings of International Symposium Held at Chengdu, China, 5-9 July 1992. *Edited by* D. E. Walling, T. R. Davies, and B. Hasholt, p. 377-385.
- Chatwin, S. C., Howes, D. E., Schwab, J. W., and Swanston, D. N. 1994. A guide for management of landslide-prone terrain in the Pacific Northwest. British Columbia Ministry of Forests, Land Management Handbook no. 18.
- Church, M. and Miles, M. J. 1987. Meterological antecedents to debris flow in southwestern British Columbia; some case studies. *In* Debris Flows/Avalanches: Process, Recognition, and Mitigation. *Edited by* J. E. Costa and G. F. Wieczorck. Geological Society of America, Reviews in Engineering Geology, **7**: 63-79.
- Clague, J. J., 1989. Economic Implications of Quaternary Geology (Canadian Cordillera). *In* Chapter 1 of Quaternary Geology of Canada and Greenland. *Edited by* R. J. Fulton. Geological Survey of Canada, Geology of Canada, No. 1, p. 17-22.
- Clague, J. J. 1991. Natural hazards. Chapter 21 *In* Geology of the Cordilleran orogen in Canada. *Edited by* H. Gabrielse and C. J., Yorath. Geological Survey of Canada, Geology of Canada, no. 4, p. 803-815.
- Clague, J. J. 1996. Paleoseismology and seismic hazards, southwestern British Columbia. Geological Survey of Canada Bulletin 494, 88 p.

- Clague, J. J., and Souther, J. G. 1982. The Dusty Creek landslide on Mount Cayley, British Columbia. *Canadian Journal of Earth Sciences*, **19**: 524-539.
- Clague J. J., and Bobrowsky, P. T. 1994a. Evidence for a large earthquake and tsunami 100-400 years ago on western Vancouver Island, British Columbia. *Quaternary Research*, **41**: 176-184.
- Clague, J. J., and Bobrowsky, P. T. 1994b. Tsunami deposits beneath tidal marshes on Vancouver Island, British Columbia. *Geological Society of America Bulletin*, **106**: 1293-1303.
- Clague, J. J., Jozsa, L. A., and Parker, M. L. 1982. Dendrochronological dating of glacier dammed lakes: An example from Yukon Territory, Canada. *Arctic and Alpine Research*, **14**: 301-310.
- Clague, J. J., Evans, S. G., and Blown, I. 1985. A debris flow triggered by the breaching of a moraine-dammed lake, Klattasine Creek, British Columbia. *Canadian Journal of Earth Sciences*, **22**: 1492-1502.
- Coats, R., and Collins, L. 1984. Streamside landsliding and channel change in a suburban forested watershed: Effects of an extreme event. *In Symposium on Effects of Forest Land Use on Erosion and Slope Stability. Edited by O. Loughlin and C. L. Pearce. University of Hawaii*, p. 165-175.
- Coligado, M. C. 1982. Multi-day extreme precipitation amounts of various return periods for selected stations on Vancouver Island and the Lower Mainland, British Columbia. *Climatological Digest No. 2. British Columbia Ministry of Environment, Waste Management Branch, working report.*
- Cook, E. R., and Kairiukstis (*editors*) 1990. *Methods of dendrochronology, applications in the environmental sciences.* Kluwer Academic Publishers, Dordrecht, 394p.
- Cruden, D. M. 1977. The dynamics of the Hope Slide. *Bulletin of the International Association of Engineering Geology*, **16**: 94-98.
- Cruden, D. M. 1991. A simple definition of a landslide. *Bulletin of the International Association for Engineering Geology*, **43**: 27-29.
- Cruden, D. M., and Varnes, D. J. 1996. Landslide types and processes. Chapter 3 *In Landslides, investigation and mitigation. Edited by A. K. Turner and R. L. Schuster. Transportation Research Board, National Research Council, Special Report 247, Washington DC.*
- Cruden, D. M., Thomson, S., Bornhold, B. D., Chagnon, J. Y., Locat, J., Evans, S. G., Heginbottom, J. A., Morgan, K., Piper, D. J. W., Powell, R., Prior, D., and Quigley, R.

- M. 1989. Landslides: Extent and Economic Significance; *In Proceedings of the 28th International Geological Congress: Symposium on Landslides. Edited by E. E. Brabb and B. L. Harrod. United States Geological Survey, Washington, DC, p. 1-12.*
- Duncan, J. M. 1996. Soil slope stability analysis. Chapter 13 *In Landslides, investigation and mitigation. Edited by A. K. Turner and R. L. Schuster. Transportation Research Board, National Research Council, Special Report 247, Washington DC.*
- Environment Canada 1993. Canadian climate normals, 1961-90, British Columbia. Environment Canada Atmospheric Environment Service.
- Evans, S. G. 1982. Landslides and surficial deposits in urban areas of British Columbia: A review. *Canadian Geotechnical Journal*, **19**: 269-288.
- Evans, S. G. 1986. Landslide damming in the Cordillera of western Canada. *In Landslide dams: Processes, risk, and mitigation. Edited by R. L. Schuster. American Society of Civil Engineers, Geotechnical Special Publication*, **3**: 111-130.
- Evans, S. G. 1989a. The Mount Colonel Foster rock avalanche and associated displacement wave, Vancouver Island, British Columbia. *Canadian Geotechnical Journal*, **26**: 452-477.
- Evans, S. G. 1989b. Earthquake-induced landslides in the Canadian Cordillera. Abstracts with Programs, Geological Society of America, **21**: 77.
- Evans, S. G. 1992. High magnitude-low frequency catastrophic landslides in British Columbia. *In Geologic Hazards in British Columbia. Proceedings of the 1991 Geologic Hazards Workshop, Open File 1992-15, p. 71-98.*
- Evans, S. G., and Lister, D. R. 1984. The geomorphic effect of the July 1983 rainstorms in the southern Cordillera and their impact on transportation facilities. *In Current Research, Part B. Geological Survey of Canada, Paper 84-1B, p. 223-235.*
- Evans, S. G., and Clague, J. J. 1988. Destructive landslides in the Canadian Cordillera; 1850-1957. Geological Survey of Canada, Paper 84-19.
- Evans, S. G., and Clague, J. J. 1989. Rain-induced landslides in the Canadian Cordillera, July 1988. *Geoscience Canada*, **16**: 193-200.
- Evans, S. G., and Gardner, J. S. 1989. Geological hazards in the Canadian Cordillera. *In Chapter 12 of Quaternary Geology of Canada and Greenland. Edited by R. J. Fulton. Geological Survey of Canada, Geology of Canada, No. 1.*

- Evans, S. G., Aitken, J. D., Wetmiller, R. J., and Horner, R. B. 1987. A rock avalanche triggered by the October 1985 North Nahanni earthquake, District of Mackenzie, N.W.T.. *Canadian Journal of Earth Science*, **25**: 176-184.
- Evans, S. G., Clague, J. J., Woodsworth, G. J. and Hungr, O. 1989. The Pandemonium Creek rock avalanche, British Columbia. *Canadian Geotechnical Journal*, **26**: 427-446.
- Fannin, R. J. 1991. Sediment transport in the Tsitika watershed - the large debris fan. British Columbia Ministry of Forests, Forest Service Research Branch (unpublished).
- Fannin, R. J., Rollerson, T., Hogan, D., and Daust, D. 1992. Characteristics of a large debris flow channel. *In Geotechnique and Natural Hazards. Proceedings of the 1992 Symposium*, p. 311-318.
- Forgis Resource Consultants Ltd. 1991. A review of the report entitled Lower Tsitika valley, a case for preservation "Changing forest values". British Columbia Ministry of Forests, 9 p.
- Gimbarzevsky, P. 1988. Mass wasting on the Queen Charlotte Islands - A regional inventory, British Columbia. British Columbia Ministry of Forests, Land Management Report, **29**.
- Guidicini, G., and Iwasa, O. Y. 1977. Tentative correlation between rainfall and landslide in a humid tropical environment. *Bulletin of the International Association of Engineering Geology*, **16**: 13-20.
- Hewlett, J. D. 1982. Principles of forest hydrology. University of Georgia Press, Athens.
- Hogan, D. L., and Schwab, J. W. 1990. Precipitation and runoff characteristics, Queen Charlotte Islands, British Columbia Ministry of Forests. Land Management Report, **60**.
- Hogan, D. L., and Schwab, J. W. 1991a. Meteorological conditions associated with hillslope failures on the Queen Charlotte Islands. British Columbia Ministry of Forests, Land Management Report **73**.
- Hogan, D. L., and Schwab, J. W. 1991b. Stream channel response to landslides in the Queen Charlotte Islands, B.C.. Changes affecting Pink and Chum Salmon Workshop, Pacific Salmon Commission.
- Hogg, W. D., and Carr, D. A. 1985. Rainfall frequency atlas for Canada, Atmospheric Environment Service, Environment Canada.
- Holland, S. S. 1964. Landforms of British Columbia, a physiographic outline. British Columbia, Geological Survey of Canada, Memoir 272.

- Howes, D. E. 1981a. Terrain inventory and geological hazards: Northern Vancouver Island. British Columbia Ministry of Environment, Assessment and Planning Division, APD Bulletin 5.
- Howes, D. E. 1981b. Late Quaternary sediments and geomorphic history of North-Central Vancouver Island. *Canadian Journal of Earth Science*, **18**: 1-12.
- Howes, D. E. 1983. Late Quaternary sediments and geomorphic history of Northern Vancouver Island, British Columbia. *Canadian Journal of Earth Science*, **20**: 57-65.
- Howes, D. E., and Kenk, E. (*Editors*) 1988. Terrain classification system for British Columbia (revised edition). British Columbia, Recreational Fisheries Branch, Ministry of Environment, Surveys and Resource Mapping Branch, and Ministry of Crown Lands. Ministry of Environment Manual 10.
- Howes, D. E., and Sondheim, M. 1988. Quantitative definitions of stability classes as related to post-logging clearcut landslide occurrence. *In Part II, Proceedings of the 10th B. C. Soil Science Workshop*. British Columbia Ministry of Forests Land Management Report **56**: 167-184.
- Hsu, K. J. 1975. Catastrophic debris streams (sturzstroms) generated by rockfalls. *Geological Society of America Bulletin*, **86**: 129-140.
- Hupp, C. R. 1991. An overview of tree-ring and plant ecological applications in geomorphology, *Eos Transactions, American Geophysical Union*, **72**: 137.
- Hupp, C. R., Osterkamp, W. R., and Thorton, J. L. 1987. Dendrogeomorphic evidence and dating of recent debris flows on Mount Shasta, Northern California. United States Geological Survey Professional Paper 1369-B.
- Jacoby, G. C., Sheppard, P. R., and Carver, G. A. 1989. Dating of earthquake-induced landslides using tree-ring analysis. *Abstracts with Programs, Geological Society of America*, **21**: 97.
- Jacoby, G. C., Williams, P. L., and Buckley, B. M. 1990. Timing and distribution of landslides in Lake Washington, Seattle: Geohazards of possible seismic origin. *Eos Transactions, American Geophysical Union*, **71**: 1560.
- Jacoby, G. C., Williams, P. L., and Buckley, B. M. 1992. Tree ring correlation between prehistoric landslides and abrupt tectonic events in Seattle, Washington. *Science*, **258**: 1621-1623.
- Jensen, J. M. 1983. The Upper Gros Ventre Landslide of Wyoming: A dendrochronology of landslide events and the possible mechanics of failure. *Abstracts*

with Programs, South-Central Section of the Geological Society of America, 17th Annual Meeting, **15**: 387.

Jozsa, L. A. 1981. Dating a landslide in the Mt. Cayley area by analysis of tree-rings. Report to the Geological Survey of Canada by Fornitek Canada Corporation.

Jozsa, L. A. 1988. Increment core sampling techniques for high quality cores. Wood Science Department, Fornitek Canada Corporation, SP-30.

Jungen, J. 1980. Terrain classification map of Adam River, British Columbia, 92L8 (1:50,000 scale map). Resource Analysis Branch, British Columbia Ministry of Environment.

Kashiwaya, K., Okimura, T., and Kawatani, T. 1989. Tree ring information and rainfall characteristic for landslide in the Kobe district, Japan. *Earth Surface Processes and Landforms*, **14**: 63-71.

Keefer, D. K. 1981. Catastrophic rock avalanches triggered by earthquakes. Programs with Abstracts, Geological Society of America, 94th Annual Meeting, **13**: 484.

Keefer, D. K. 1984. Landslides caused by earthquakes. *Geological Society of America Bulletin*, **95**: 406-421.

Keefer, D. K. 1989. Characteristics of earthquake-induced landslides. Abstracts with Programs, Geological Society of America, Cordillera Section, 85th Annual Meeting, **21**: p. 100.

Klinka, K., Green, R. N., and Courtin, P. J. 1984. Site diagnosis, tree species selection, and slashburning guidelines for the Vancouver Forest Region. British Columbia Ministry of Forests, Land Management Report, **25**.

Krag, R. K., Sauder, E. A., and Wellburn, G. V. 1986. Forest engineering analysis of landslides in logged areas on the Queen Charlotte Islands. British Columbia Ministry of Forests, Land Management Report, **43**.

Larson, R. A. 1995. Slope failures in Southern California: Rainfall threshold, prediction and human causes. *Environmental and Engineering Geoscience*, **1**: 393-401.

Lowe, D. R. 1979. Sediment gravity flows; their classification and some problems of application to natural flows and deposits. *In* *Geology of Continental Slopes*. Edited by L. J. Doyle, and O. H. Pilkey. Society of Economic Paleontologists and Mineralogists Special Publication **27**: 75-82.

Luckman, B. H. 1988. Dating the moraines and recession of the Athabasca and Dome Glaciers, Alberta, Canada. *Arctic and Alpine Research*, **20**: 40-54.

- Mathews, W. H. 1979. Landslides of Central Vancouver Island and the 1946 earthquake. *Seismological Society of America, Bulletin*, **69**: 445-450.
- Maynard, D. 1991 (unpublished). Tsitika River watershed: Sediment source inventory. British Columbia Ministry of Forests, Research Branch.
- Mokievsky-Zubock, O. 1977. Glacier-caused slide near Pylon Peak, British Columbia. *Canadian Journal of Earth Sciences*, **14**: 2657-2662.
- Moore, D. P. and Mathews, W. H. 1978. The Rubble Creek landslide, Southwestern British Columbia. *Canadian Journal of Earth Sciences*, **15**: 1039-1052.
- Muller, J. E., and Roddick, J. A. 1983. Map 1552A, Geology; Alert Bay - Cape Scott British Columbia. Geological Survey of Canada.
- Muller, J. E., Northcote, K. E., and Carlisle, D. 1974. Geology and mineral deposits of Alert Bay - Cape Scott map area (92L-1021) Vancouver Island. British Columbia Geological Survey of Canada Paper 74-8.
- Nixon, G. T., Hammack, J. L., Koyanagi, V. M., Payie, G. J., Panteleyev, A., Massey, N. W. D., Hamilton, J. V., and Haggart, J. W. 1994. Preliminary geology of the Quatsino - Port McNeill map areas, Northern Vancouver Island (92L/12, 11). British Columbia Geological Survey Branch, Geological Fieldwork 1993, Paper, 1994-1, p. 63-85.
- North Island Study Group 1975. Tsitika-Schoen resources study. Technical report v. 1, Environment and Land Use Committee, Province of British Columbia, 48 p.
- Nuszdorfer, F. C., Kassay, K. L., and Scagel, A. M. 1985. Biogeoclimatic units of the Vancouver forest region (1:500,000 scale map). Province of British Columbia Ministry of Forests, Research Branch, Victoria British Columbia.
- Parish, R. 1994. Tree book: Learning to recognize trees of British Columbia. British Columbia Ministry of Forests, 183 p.
- Parish, R., and Parminter, J. 1994. Role of disturbance in British Columbia's forests. Preliminary unpublished Ministry of Forests report. British Columbia, Ministry of Forests.
- Parker, M. L., and Jozsa, L. A. 1981. Dendrochronological investigations along the MacKenzie, Liard and South Nahanni rivers, Northwest Territories. Part I: Using tree damage to date landslides, ice jamming, and flooding. *In* Hydrologic aspects of northern pipeline development. Environmental-Social Committee, Northern Pipelines, Task Force on Northern Oil Development, Report No. 73-3, Technical Report 10, p. 313-324.

- Pierson, T. C., and Costa, J. E. 1987. A rheologic classification of subaerial sediment-water flows. *In* Debris flows/avalanches: Process, recognition and mitigation. *Edited by* J. E. Costa and G. F. Wieczorek. Geological Society of America, Reviews in Engineering Geology, Volume VII, p. 1-12.
- Pojar, J., Klinka, K., and Meidinger, D. V. 1987. Biogeoclimatic ecosystem classification in British Columbia. *Forest Ecology and Management*, **23**: 119-154.
- Pugsley, W. I. 1981. Flood hydrology guide for Canada; hydrometeorological design techniques. Atmospheric Environment Service, Environment Canada.
- Resource Inventory Committee (RIC) 1996. Guidelines and standards to terrain geology mapping in British Columbia. Terrain Geology Task Group, Earth Science Task Force, Resource Inventory Committee, British Columbia.
- Richter, C. F. 1958. Elementary Seismology. W. H. Freeman Co., San Francisco, CA, 768 p.
- Ritter, D. F. 1978. Process geomorphology. Wm. C. Brown Publishers, Dubuque, Iowa, 603 p.
- Roddick, J. A. 1980. Geology of Northeast Alert Bay map area. British Columbia, Geological Survey of Canada, Open File 722,
- Rogers, G. C. 1976. The Vancouver Island earthquake of 5 July 1972. *Canadian Journal Earth Sciences*, **13**: 92-101.
- Rogers, G. C. 1980. A documentation of soil failure during the British Columbia earthquake of 23 June, 1946. *Canadian Geotechnical Journal*, **17**: 122-127.
- Rogers, G. C. 1987. Vertical motions in the Vancouver Island region: Possible evidence for a megathrust earthquake environment. *Eos Transactions, American Geophysical Union*, **68**: 1468.
- Rogers, G. C. 1988. An assessment of the megathrust earthquake potential of the Cascadia subduction zone. *Canadian Journal of Earth Sciences*, **25**: 844-852.
- Rogers, G. C. 1992. Earthquake hazard in British Columbia. *In* Geologic Hazards in British Columbia. Proceedings of the 1991 Geologic Hazards Workshop, Open File 1992-15, p. 127-130.
- Rogers, G. C., and Hasegawa, H. S. 1978. A second look at the British Columbia earthquake of June 23, 1946. *Bulletin of the Seismological Society of America*, **68**: 653-675.

Rollerson, T. P. 1992. Relationships between landscape attributes and landslide frequencies after logging: Skidegate Plateau, Queen Charlotte Islands. British Columbia Land Management Report, 76.

Rood, K. M. 1984. An aerial photograph inventory of the frequency and yield of mass wasting on the Queen Charlotte Islands, British Columbia. British Columbia Ministry of Forests, Land Management Report, 34.

Ryder, J. M., and Clague, J. J. 1989. British Columbia (Quaternary stratigraphy and history, Cordilleran Ice Sheet). *In* Chapter 1 of Quaternary Geology of Canada and Greenland. *Edited by* R. J. Fulton. Geological Survey of Canada, Geology of Canada, No. 1, p. 48-53.

Satake, K. 1995. A possible Cascadia earthquake of January 26, 1700 as inferred from tsunami records in Japan. Program and Abstracts of the 1995 Geological Association of Canada/ Mineralogical Association of Canada Annual Meeting, p. A-93.

Sauder, E. A., Krag, R. K., and Wellburn, G. V. 1987. Logging and mass wasting in the Pacific Northwest with application to the Queen Charlotte Islands, B.C. Ministry of Forests Land Management Report, no. 53.

Savigny, W. K., Sego, D. C., and MacInnes, K. L. 1992. The Little Doctor Lake landslide, an example of coseismic reactivation of a landslide in permafrost terrain. *In* Geotechnique and Natural Hazards, Proceedings of the 1992 Symposium, p. 203-209.

Schwab, J. W. 1983. Mass wasting: October-November 1978 storm, Rennell Sound, Queen Charlotte Islands, British Columbia. British Columbia Ministry of Forests Research Note, No. 91.

Schweingruber, F. H. 1988. Tree rings: Basics and applications of dendrochronology. Kluwer Academic Publishers, Dordrecht.

Septer, D., and Schwab, J. W. 1995. Rainstorm and flood damage: Northwest British Columbia 1891-1991. British Columbia, Ministry of Forests Land Management Handbook, 31.

Senyk, J. 1980. Terrain classification map of Nimpkish, British Columbia; 92L8 (1:50,000 scale map). Resource Analysis Branch, British Columbia Ministry of Environment.

Shroder, J. F. Jr. 1978. Dendrogeomorphological analysis of mass movement on Table Cliffs Plateau, Utah. *Quaternary Research*, 9: 168-185.

Shroder, J. F. Jr. 1980. Dendrogeomorphology: Review and new techniques in tree-ring dating. *Progress in Physical Geography*, 4: 161-188.

- Shroder, J. F. Jr. 1985. Dendrochronologic applications in geomorphology. *Bulletin of the Ecological Society of America, Program Issue with Abstracts*, p. 271-272.
- Shroeder, W. L., and Brown, G. W. 1984. Debris torrents, precipitation, and roads in two coastal Oregon watersheds. *Symposium on effects of forest land use on erosion and slope stability. Edited by O. Loughlin and C. L. Pearce, University of Hawaii*, p. 117-222.
- Skermer, N. A. 1973. Earthquakes, avalanches, landslides. *The B.C. Professional Engineer*, **24**: 5-8.
- Skermer, N. A. 1985. Climequakes. *The B.C. Professional Engineer*, **36**: 7-8.
- Slosson, J. E., and Larson, R. A. 1995. Slope failure in Southern California, rainfall threshold, prediction and human causes. *Environmental and Engineering GeoScience*, **1**: 393-401.
- Smith, D. J., and Laroque, C. P. 1996. Dendroglaciological dating of a Little Ice Age glacial advance at Moving Glacier, Vancouver Island, British Columbia. *Geographie physique et Quaternaire*, **50**: 47-55.
- Smith R. B., Commandeur, P. R., and Ryan, M. W. 1986. Soils, vegetation, and forest growth on landslides and surrounding logged and old-growth areas on the Queen Charlotte Islands, British Columbia. *British Columbia Ministry of Forests, Land Management Report*, **41**.
- Spindler, C., and Rogers, G. C. 1989. The 1978 Brooks Peninsula, Vancouver Island earthquakes. *Seismological Research Letters*, **60**: 7.
- Sterling, S. 1996. The effect of geology on magnitude and frequency of debris torrents on the Tsitika watershed. Unpublished M.Sc. Thesis, University of British Columbia.
- Strunk, H. 1989. Dendrogeomorphology of debris flows. *Dendrochronologia*, **7**: 15-25.
- Swanston, D. N., and Howes, D. E. 1994a. A technique for stability hazard assessment. Chapter 2 *In A Guide for Management of Landslide Prone Terrain in the Pacific Northwest. Edited by S. C. Chatwin, D. E., Howes, J. W. Schwab, and D. N. Swanston. British Columbia Ministry of Forests, Land Management Handbook*, **18**.
- Swanston, D. N., and Howes, D. E. 1994b. Slope movement processes and characteristics. Chapter 1 *In A Guide for Management of Landslide Prone Terrain in the Pacific Northwest. Edited by S. C. Chatwin, D. E., Howes, J. W. Schwab, and D. N. Swanston. British Columbia Ministry of Forests, Land Management Handbook*, **18**.

- Terasmae, J. 1975. Dating of landslides in the Ottawa River valley by dendrochronology - a brief comment. *In Mass Wasting, 4th Guelph Symposium on Geomorphology. Edited by E. Yatsu, A. J. Ward, and F. Dahms. Geoabstracts, Norwich, p. 153-158.*
- Tsitika Follow-up Committee 1991. Results of a survey conducted in November 1990, Volume 1 - summary of results. Campbell River Forest District Office, 17 p.
- VanDine, D. F. 1985. Debris flows and debris torrents in the southern Canadian Cordillera, *Canadian Geotechnical Journal*, **22**: 44-68.
- VanDine, D. F. 1992. Low magnitude/high frequency mass movements. *In Geologic Hazards in British Columbia. Proceedings of the 1991 Geologic Hazards Workshop, Open File 1992-15, p. 99-104.*
- VanDine, D. F., and Evans, S. G. 1992. Large landslides on Vancouver Island, British Columbia. *In Geotechnique and Natural Hazards, Proceedings of the 1991 Symposium, p. 193-201.*
- Varnes, D. J. 1978. Slope movement types and processes. *In Landslides; analysis and control. Edited by R. L. Schuster and R. J. Krizck. Transportation Research Board National Academy of Sciences, Washington, DC, Special Report 176, p. 11-33.*
- Weichert, D., Horner, R. B., and Evans, S. G. 1994. Seismic signatures of landslides: The 1990 Brenda Mine collapse and the 1965 Hope rockslides. *Bulletin of the Seismological Society of America*, **84**: 1523-1532.
- Wetmiller, R. J., and Evans, S. G. 1989. Analysis of the earthquakes associated with the 1965 Hope landslide and their effects on slope stability at the site. *Canadian Geotechnical Journal*, **26**: 484-490.
- Western Canada Wilderness Committee 1990. Lower Tsitika valley, a case for preservation, a report and critique to the Tsitika follow-up committee. Victoria British Columbia, 14 p.
- Whitehouse, I. E., and Griffiths, G. A., 1983, Frequency and Hazard of Large Rock Avalanches in the Central Southern Alps, New Zealand, *Geology*, 11, p. 331-334.
- Wieczorek, G. F. 1996. Landslide triggering mechanisms. Chapter 4 *In Landslides, investigation and mitigation. Edited by A. K. Turner and R. L. Schuster. Transportation Research Board, National Research Council, Special Report 247, Washington DC.*
- Wu, T. H. 1996. Soil strength properties and their measurement. Chapter 12 *In Landslides, investigation and mitigation. Edited by A. K. Turner and R. L. Schuster. Transportation Research Board, National Research Council, Special Report 247, Washington DC.*

Wuethrich, B. 1994. It's official: Quake danger in northwest rivals California's. *Science*, **256**: 1802-1803.

Yorath, C. J., and Nasmith, H. W. 1995. *The geology of Southern Vancouver Island, a field guide*. Orca Book Publishers, Victoria, British Columbia, 172 p.

ID #	Type	Easting	Northing	Azimuth	Upper-slope	Mid-slope	Lower-slope	Area in m2
SC-01	Debris slide	678400	5591100	SW	34	31	27	11250
SC-02	Debris slide	678300	5590700	NNE	37	34	22	65000
SC-03	Debris slide	676500	5591500	NW	45	34	26	12000
SC-04	Debris slide	678200	5591200	SW	38	34	19	95000
SC-05	Debris slide	679800	5591100	SW	45	36	21	7000
TR-01	Debris slide	672400	5592800	W	35	22	5	14250
TR-02	Debris slide	675800	5584200	WSW	36	36	16	19000
TR-03	Debris slide	673250	5592250	W	45	36	34	8500
TR-04	Debris slide	678200	5575300	ESE	43	31	26	25000
TR-05	Debris slide	678300	5577500	NNW	37	39	34	24000
TR-06	Rockfall	674400	5591000	W	90	36	27	10000
TR-07	Debris slide	679500	5581300	SW	40	40	40	75000
TR-08	Rockfall	678800	5581900	SW	90	45	45	13700
TH-01	Debris slide	674700	5587500	SSW	34	27	24	18000
TH-02	Debris slide	675700	5587500	SSW	35	32	26	10000
TH-03	Debris slide	675900	5587200	SSW	35	32	26	11900
TH-04	Debris slide	676100	5587200	SSW	35	32	27	9500
TH-05	Debris slide	676700	5587000	SW	35	32	20	10000
TH-06	Debris slide	676800	5587000	SW	35	32	20	10000
CC-01	Debris slide	671500	5587800	NE	29	24	15	26000
CC-02	Debris slide	671500	5587700	E	26	24	22	18400
CC-03	Debris slide	669800	5587000	SE	45	35	23	8250
CC-04	Debris slide	671400	5588000	NNE	40	29	20	37500
CC-05	Debris slide	669200	5583700	NW	44	44	26	10000
CC-06	Debris slide	668800	5583600	NW	43	32	17	109400
CL-01	Rockfall/Avalanche	674000	5577000	WNW	45	25	5	600000
TL-01	Debris slide	677400	5577100	E	34	25	18	38000
TL-02	Rockfall/Avalanche	677300	5575800	NNW	90	21	11	400000
RC-01	Debris slide	687300	5580500	SE	44	27	16	9500
RC-02	Rockfall	689300	5581000	SSE	90	43	43	11000
RC-03	Debris slide	688750	5576800	NNE	40	37	18	60000

Appendix 1: Tabled landslide data.

ID #	Volume in m3	Volume to stream	Vol. inferred	Stream Order	Initial Elev.	Runout (m)
SC-01	7000	5000		3	820	750
SC-02	25000	15000		3	830	1050
SC-03	7500	3500	X	2	865	400
SC-04	40000	26000		3	1000	1300
SC-05	4400	0	X	n/a	1280	450
TR-01	4500	0		n/a	150	300
TR-02	12000	0		n/a	360	350
TR-03	4000	0	X	n/a	600	160
TR-04	10300	0		n/a	800	800
TR-05	60000	60000		2	900	600
TR-06	6000	1200	X	1	1200	230
TR-07	75000	75000	X	2	1300	900
TR-08	8500	5000	X	2	1380	500
TH-01	12000	1200		3	600	450
TH-02	3200	1000		3	760	460
TH-03	15000	15000		3	790	450
TH-04	12250	5000		3	820	400
TH-05	6000	1000	X	3	900	500
TH-06	6000	1200	X	3	920	500
CC-01	13000	0		n/a	310	650
CC-02	8000	0		n/a	355	300
CC-03	7500	1250		3	380	150
CC-04	28750	10000		3	550	900
CC-05	10000	10000		2	710	230
CC-06	139000	38750		3	860	1000
CL-01	500000	250000		4	900	1800
TL-01	13300	13300		2	920	800
TL-02	500000	>100000		1	1250	1500
RC-01	6000	0	X	n/a	850	450
RC-02	7000	0		n/a	1000	400
RC-03	40000	10000	X	2	1350	900

Appendix 1 continued: Tabled landslide data.

**Appendix II**  
**Landslide maps**

### Legend for site maps

**TR05**

Site identification number



Tree core sampling site



Gully/ ephemeral stream



Road/ mainline



Contour interval in m



Headscarp



Area of deposition



Area not removed by landslide (mature timber)

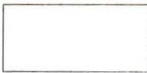

Area of scour

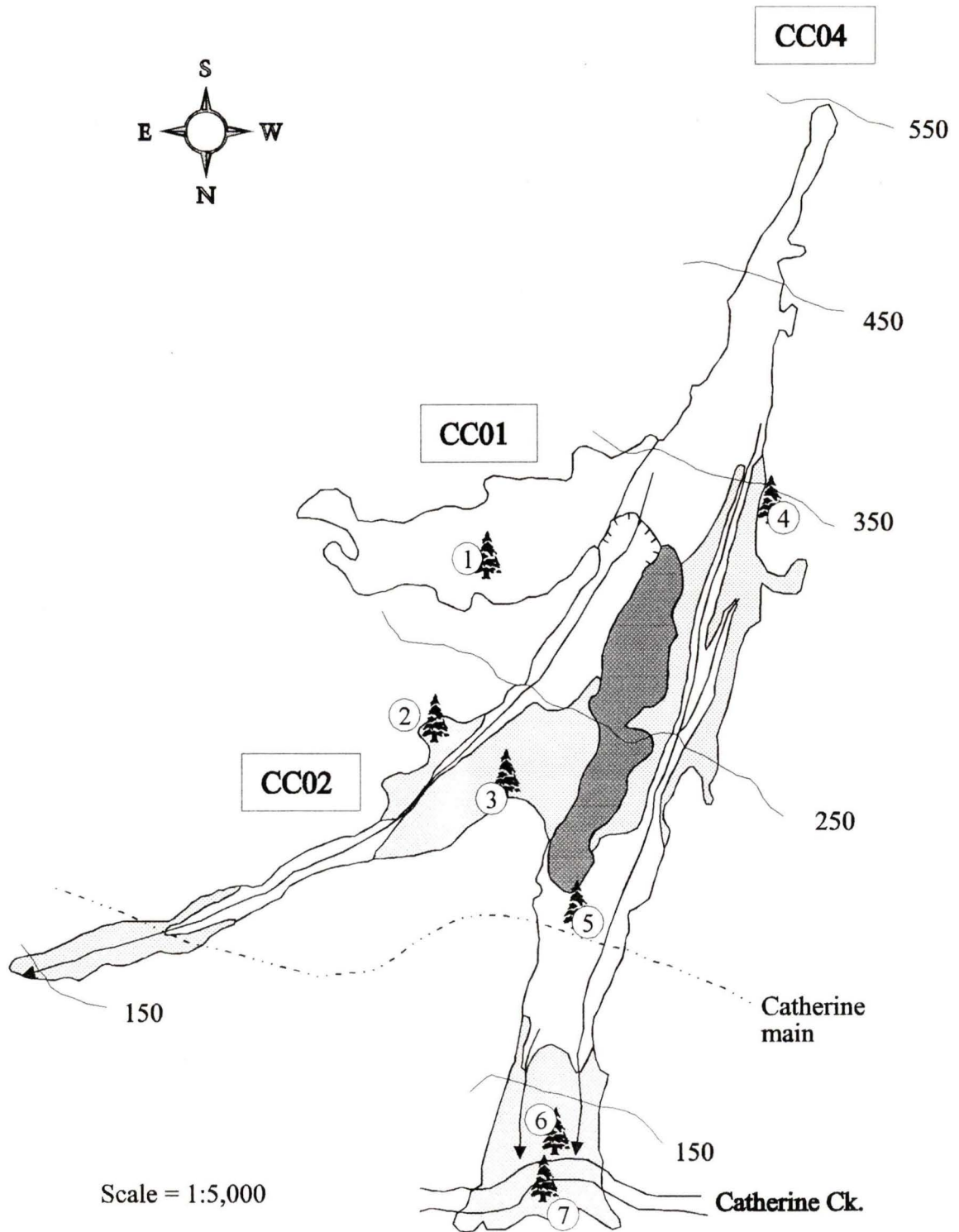

Tree core dates on the following page.

Tree cores from previous page.

CC01

Tree Cores

Tree/ Core Type/ Age (years before 1994)

1. 2 Hemlock/ Minimum/ 104, 81

CC02

Tree Cores

Tree/ Core Type/ Age (years before 1994)

2. 1 Alder/ Peripheral/ 18
3. 1 Alder/ Minimum/ 13

Other evidence: Landslide on 1976 airphotos, and absent on 1974 airphotos.

CC04

Tree Cores

Tree/ Core Type/ Age (years before 1994)

4. 1 Hemlock/ Peripheral/ 18
5. 1 Alder/ Minimum/ 15
6. 1 Alder, 1 Hemlock/ 2 Minimum/ 16, 18
7. 1 Alder/ Minimum/ 15

Other evidence: Landslide on 1976 airphotos, and absent on 1974 airphotos.

CC03

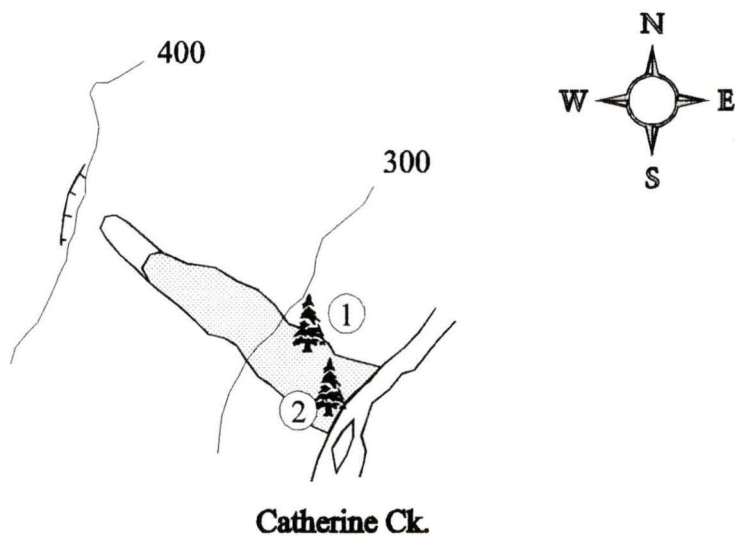

Scale = 1:5,000

## Tree Cores

Tree/ Core Type/ Age (years before 1994)

1. 1 Hemlock/ Peripheral/ 53
2. 1 Alder, 1 Hemlock/ 1 Minimum, 1 Scar/ 49, 54

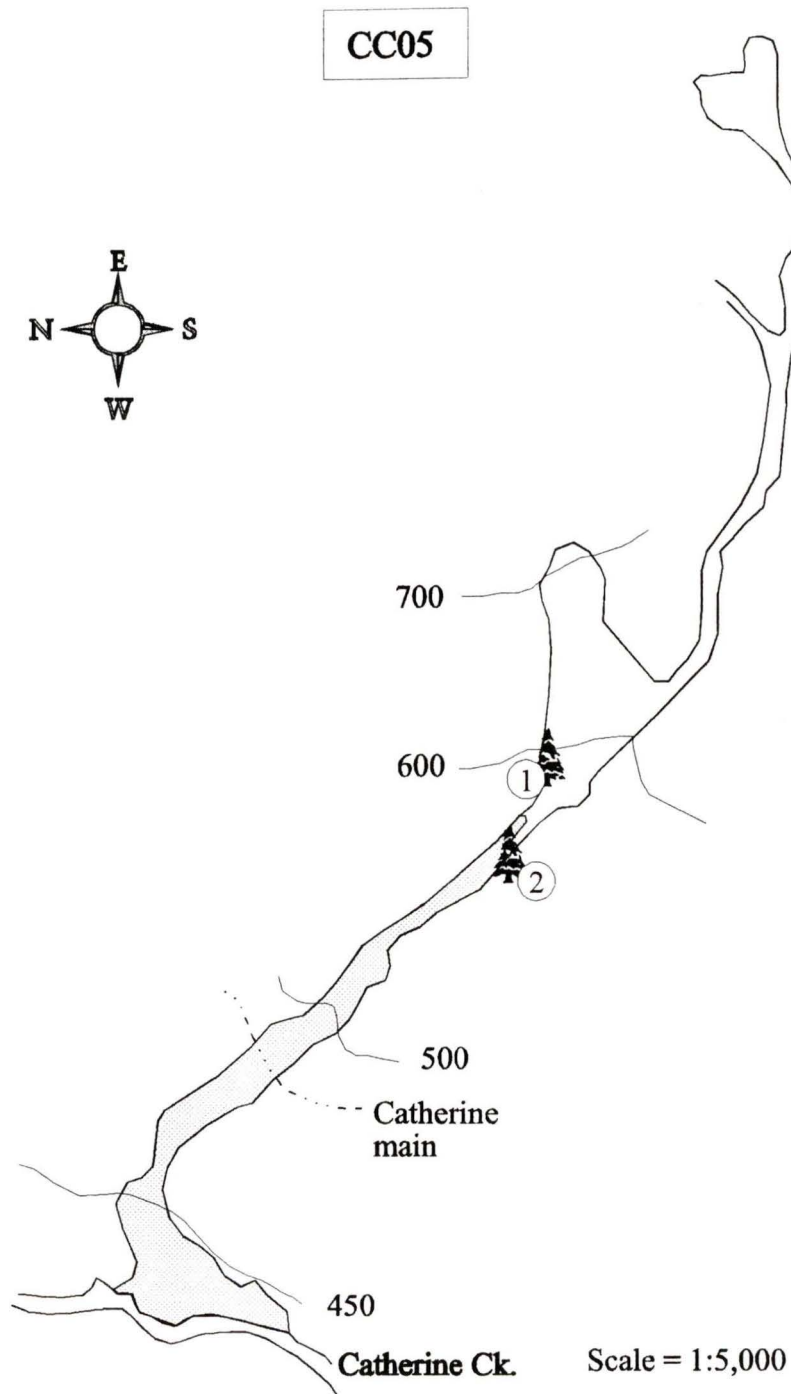

Tree Cores  
 Tree/ Core Type/ Age (years before 1994)

1. 2 Alder/ Minimum/ 58, 60
2. 1 Hemlock/ Minimum/ 66

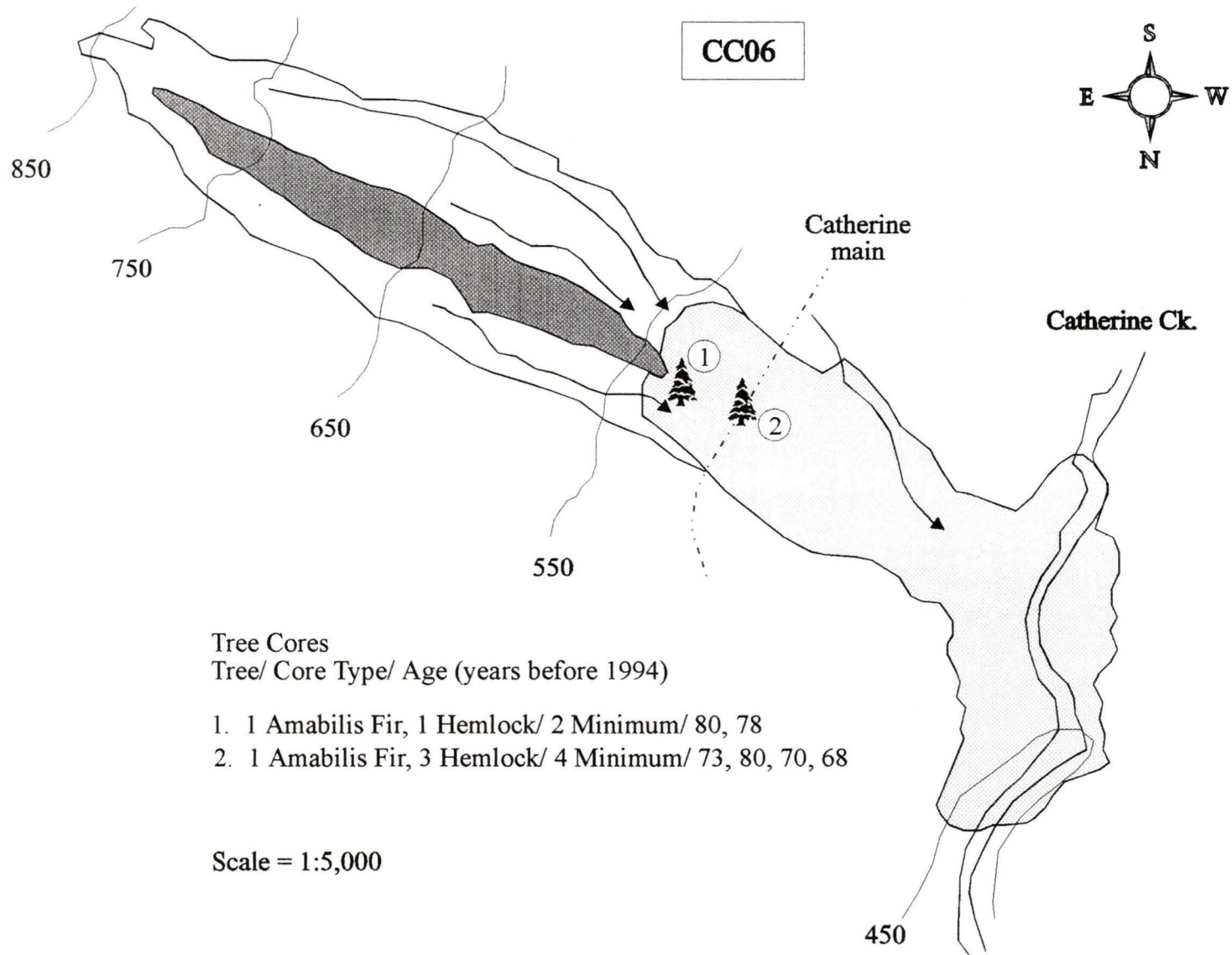

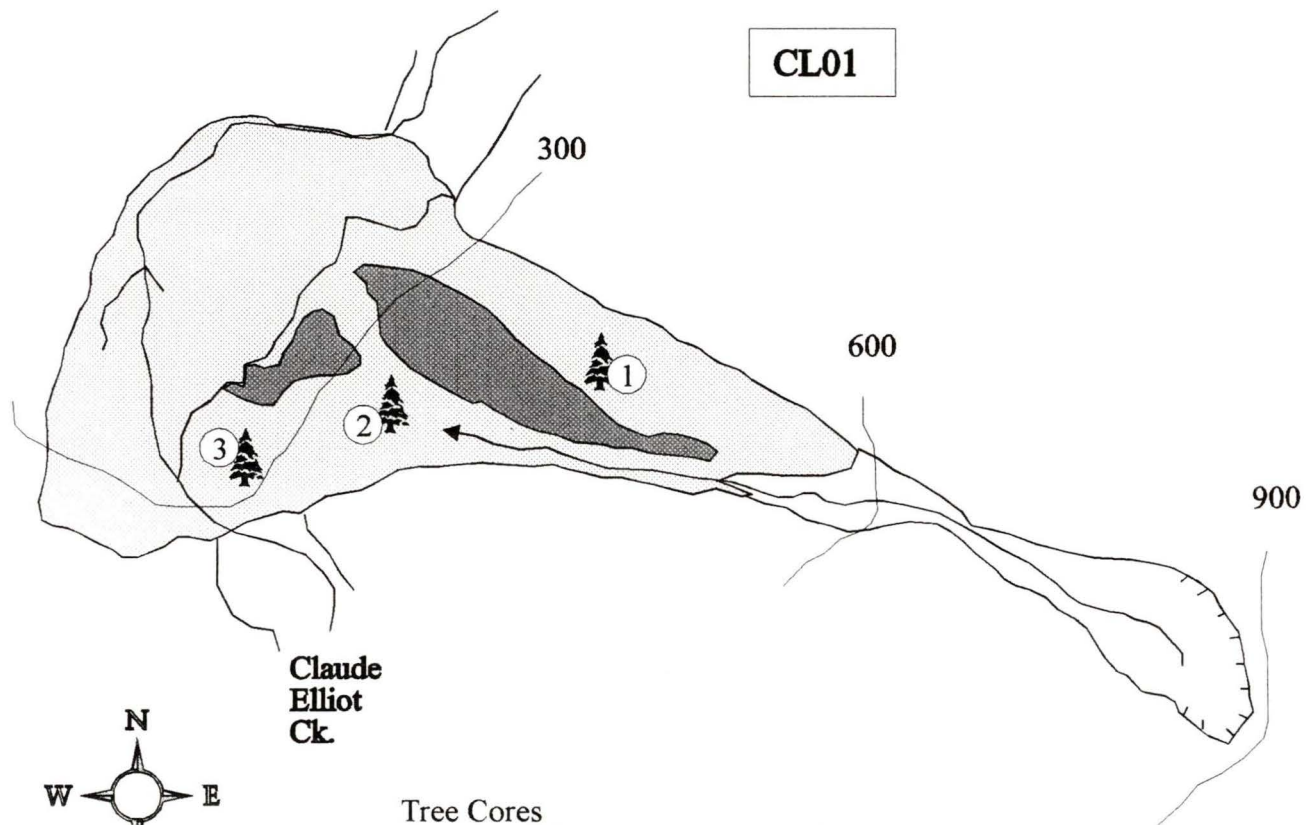

Claude  
Elliot  
Ck.

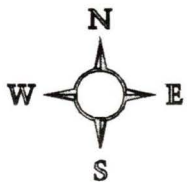

Tree Cores  
Tree/ Core Type/ Age (years before 1994)

- 1. 2 Alder/ 2 Minimum/ 42, 43
- 2. 1 Alder/ Minimum/ 42
- 3. 1 Alder/ Minimum/ 47

Scale = 1:10,000

Other evidence: Absent on BC Dept. of Lands 1929 map,  
present on same map in 1948. Fieldwork for map took place  
in 1947.

RC02

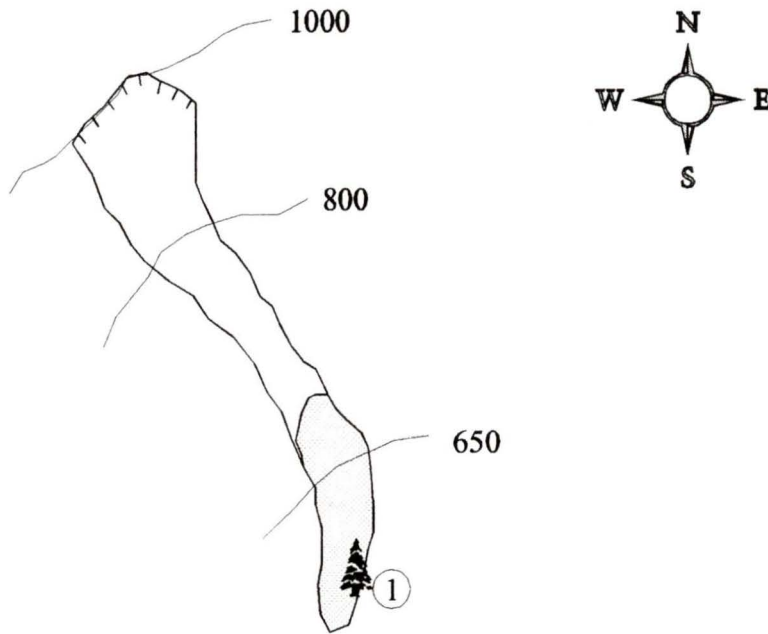

Scale = 1:5,000

**Tree Cores**

Tree/ Core Type/ Age (years before 1994)

1. 2 Hemlock/ 1 Minimum, 1 Scar/ 15, 17

Other evidence: Landslide absent on 1976 air photos.

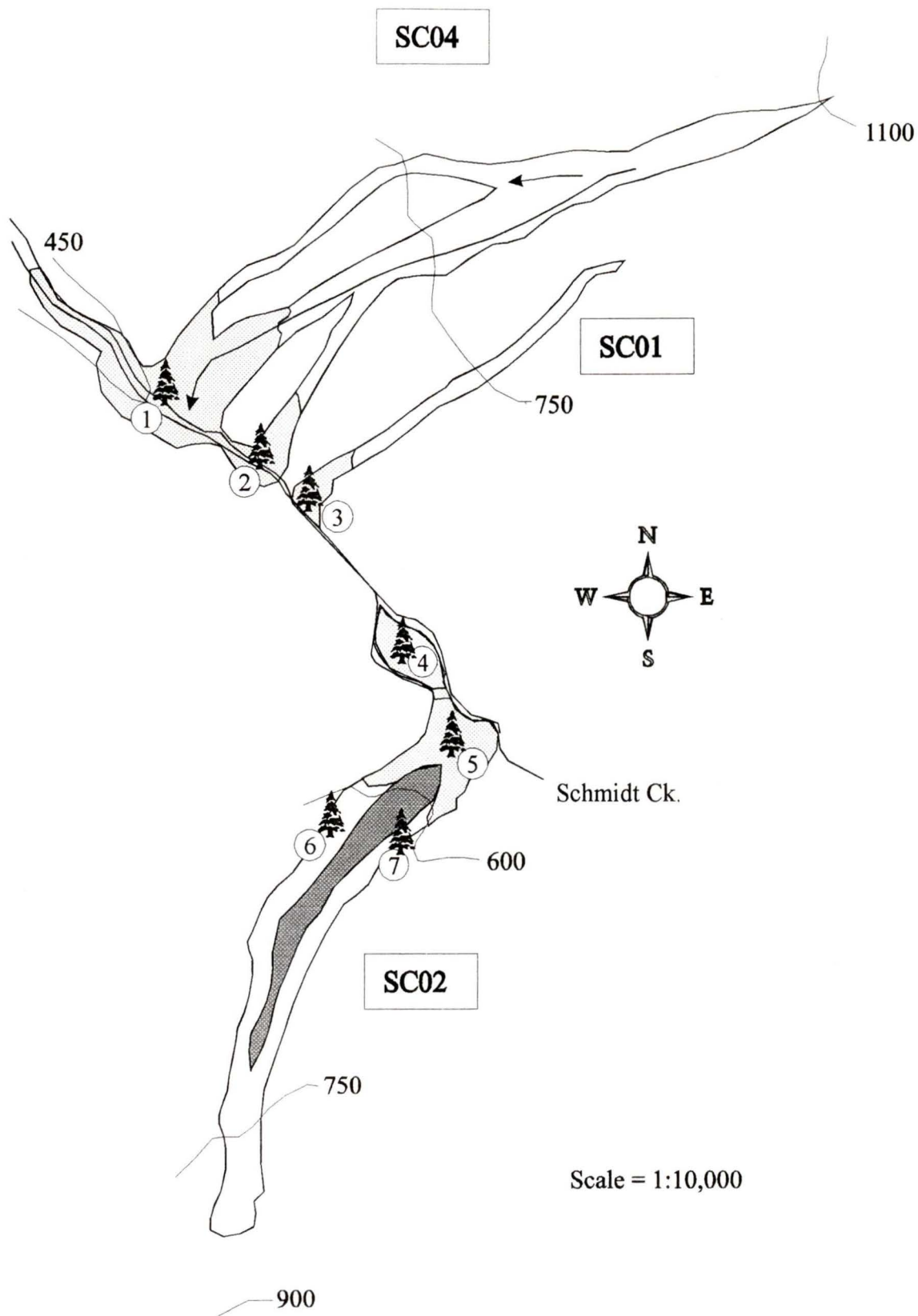

Tree core dates on following page.

Tree cores from previous page.

#### SC01

##### Tree Cores

Tree/ Core Type/ Age (years before 1994)

3. 1 Alder/ Minimum/ 60

#### SC02

##### Tree Cores

Tree/ Core Type/ Age (years before 1994)

4. 3 Alder/ Minimum/ 55, 55, 52

5. 2 Alder/ Minimum/ 38

6. 2 Alder, 1 Hemlock/ 2 Minimum, 1 Peripheral/ 25, 27, 34

7. 5 Alder, 5 Minimum (2 locations)/ 15, 15, 39, 40, 41

Other evidence: landslide SC02 is not active on 1976 air photographs.

#### SC04

##### Tree Cores

Tree/ Core Type/ Age (years before 1994)

1. 3 Alder/ Minimum/ 15, 16, 16

2. 1 Alder, 1 Hemlock/ Minimum, Scar/ 17, 16

Other evidence: landslide SC04 is not on the 1974 air photographs.

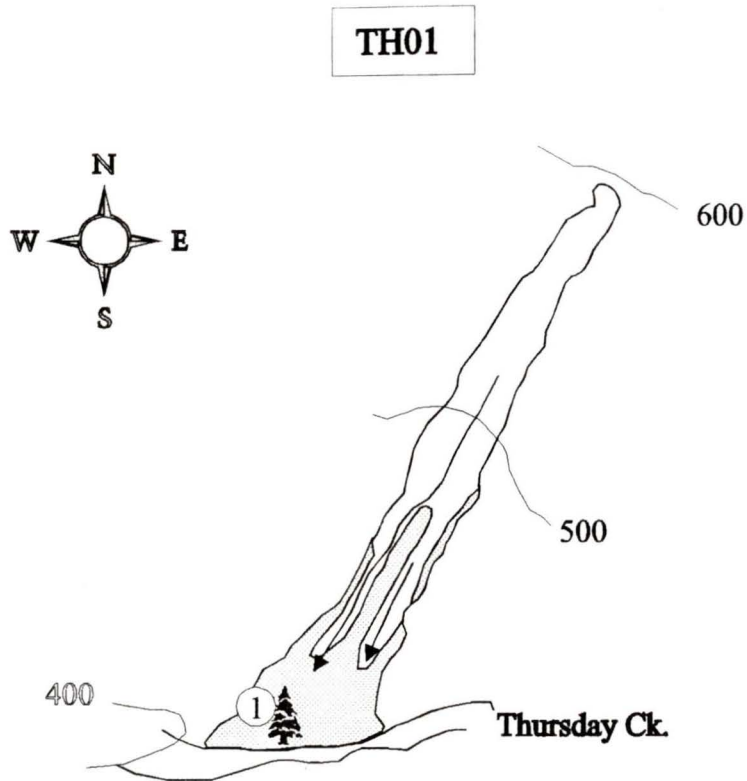

Scale = 1:5,000

#### Tree Cores

Tree/ Core Type/ Age (years before 1994)

1. 1 Hemlock, 2 Alder/ 1 Peripheral, 2 Minimum/ 18, 17, 16

Other evidence: Landslide on 1976 air photos, and absent on 1974 air photos, landslide remnant on 1953 air photos.

TH02

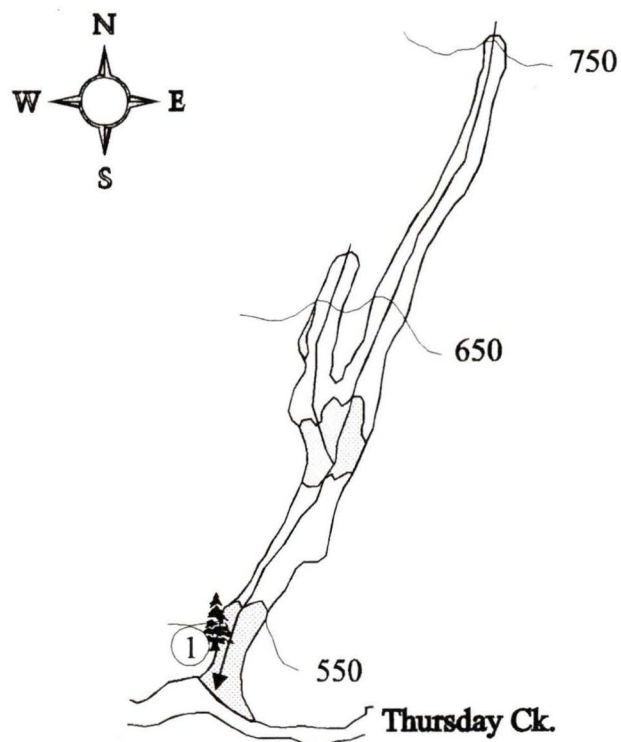

Scale = 1:5,000

Tree Cores

Tree/ Core Type/ Age (years before 1994)

1. 1 Alder/ Minimum/ 36

Other evidence: Landslide on 1953 air photos.

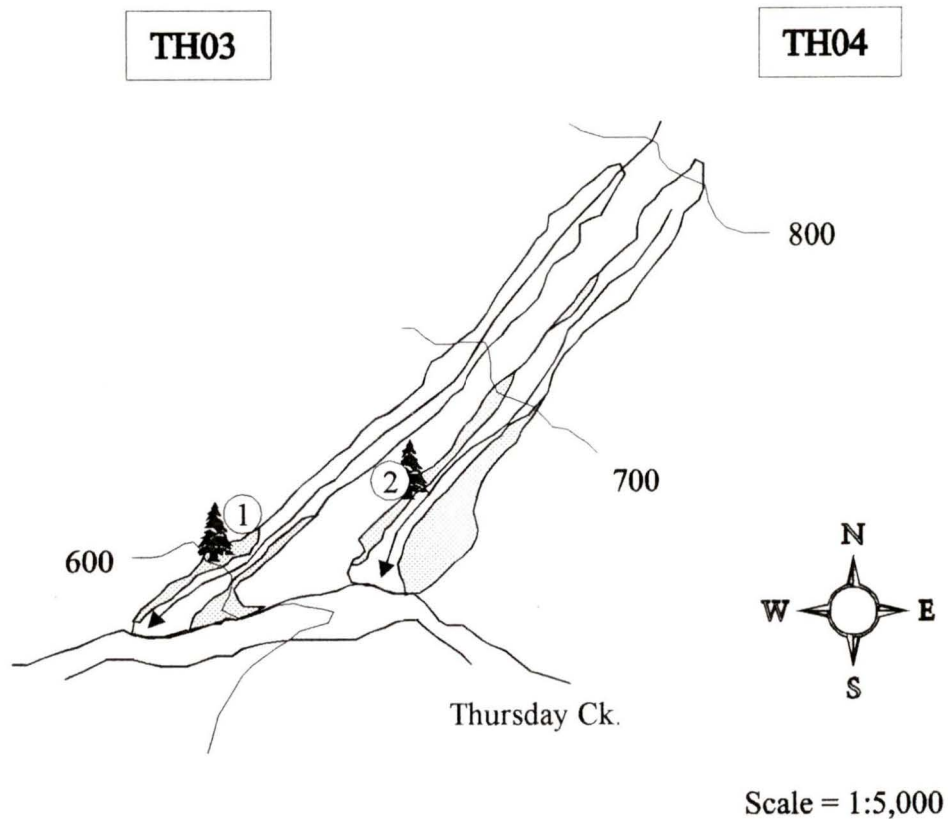

#### Tree Cores

Tree/ Core Type/ Age (years before 1994)

1. 3 Alder/ 2 Minimum, 1 Peripheral/ 30, 28, 30
2. 1 Alder/ Minimum/ 11

Other evidence: TH01 appears old on 1967 air photos and is absent on 1953 air photos. Landslide TH04 on 1976 air photos, and absent on 1974 air photos.

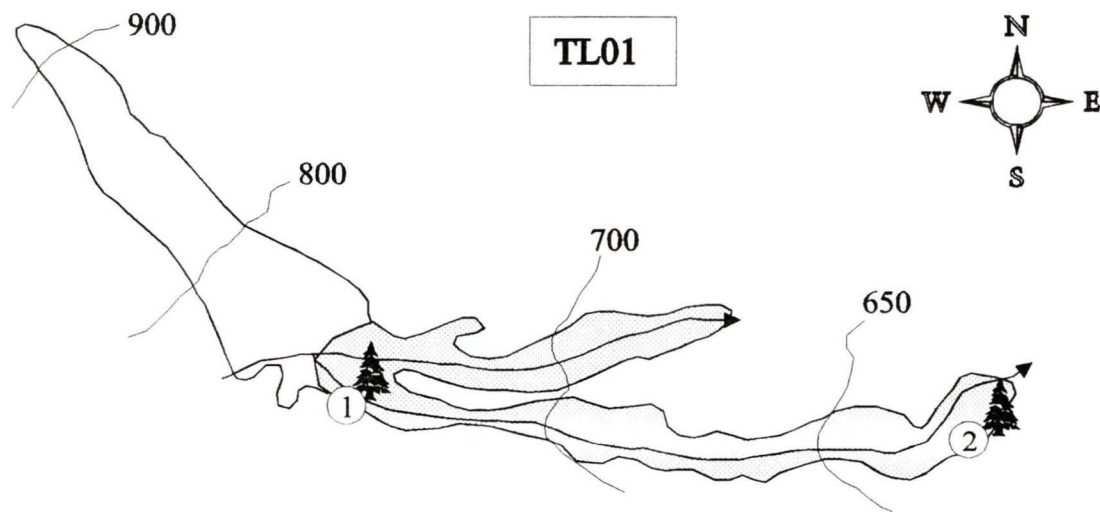

Tree Cores

Tree/ Core Type/ Age (years before 1994)

- 1. 1 Hemlock/ Minimum/ 15
- 2. 1 Hemlock/ Minimum/ 17

Other evidence: Landslide on 1967 Air photos, and absent on 1953 air photos.

Scale = 1:5,000

TL02

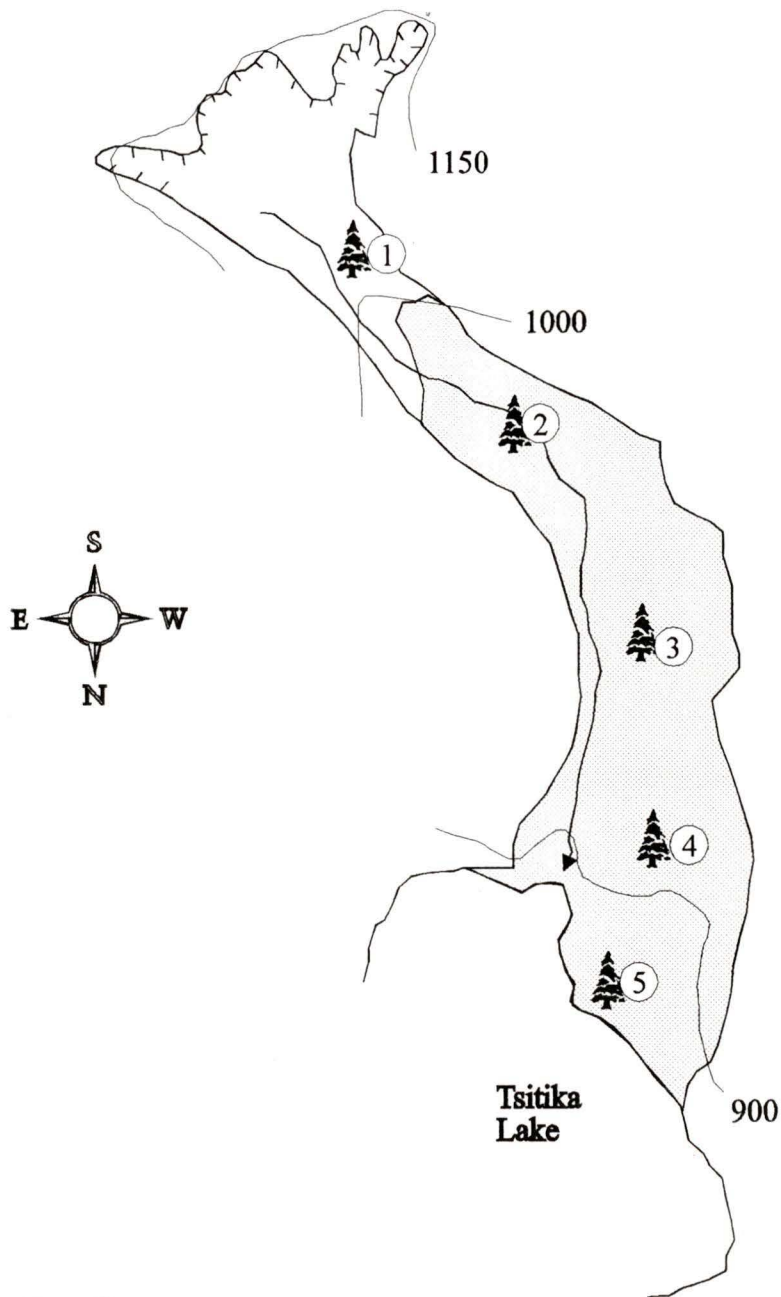

Tree Cores  
Tree/ Core Type/ Age (years before 1994)

1. 2 Hemlock/ Minimum/ 90, 59
2. 1 Hemlock/ Minimum/ 165
3. 1 Hemlock/ Minimum/ 250
4. 1 Hemlock/ Minimum/ 533
5. 1 Hemlock/ Minimum/ 609

Scale = 10,000

TR01

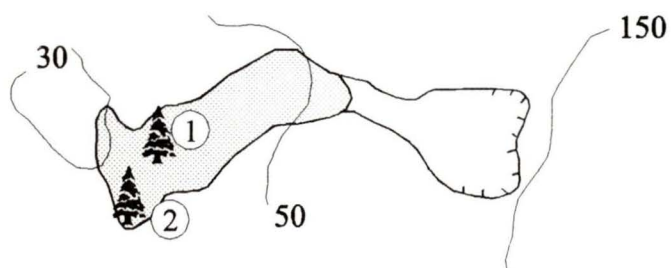

Tree Cores  
Tree/ Core Type/ Age (years before 1994)

1. 1 Alder/ Minimum/ 17
2. 1 Alder/ Minimum/ 18

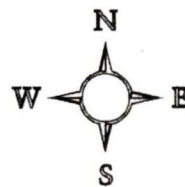

Scale = 1:5,000

Other evidence: Landslide on 1972 air photos, and absent on 1967 air photos.

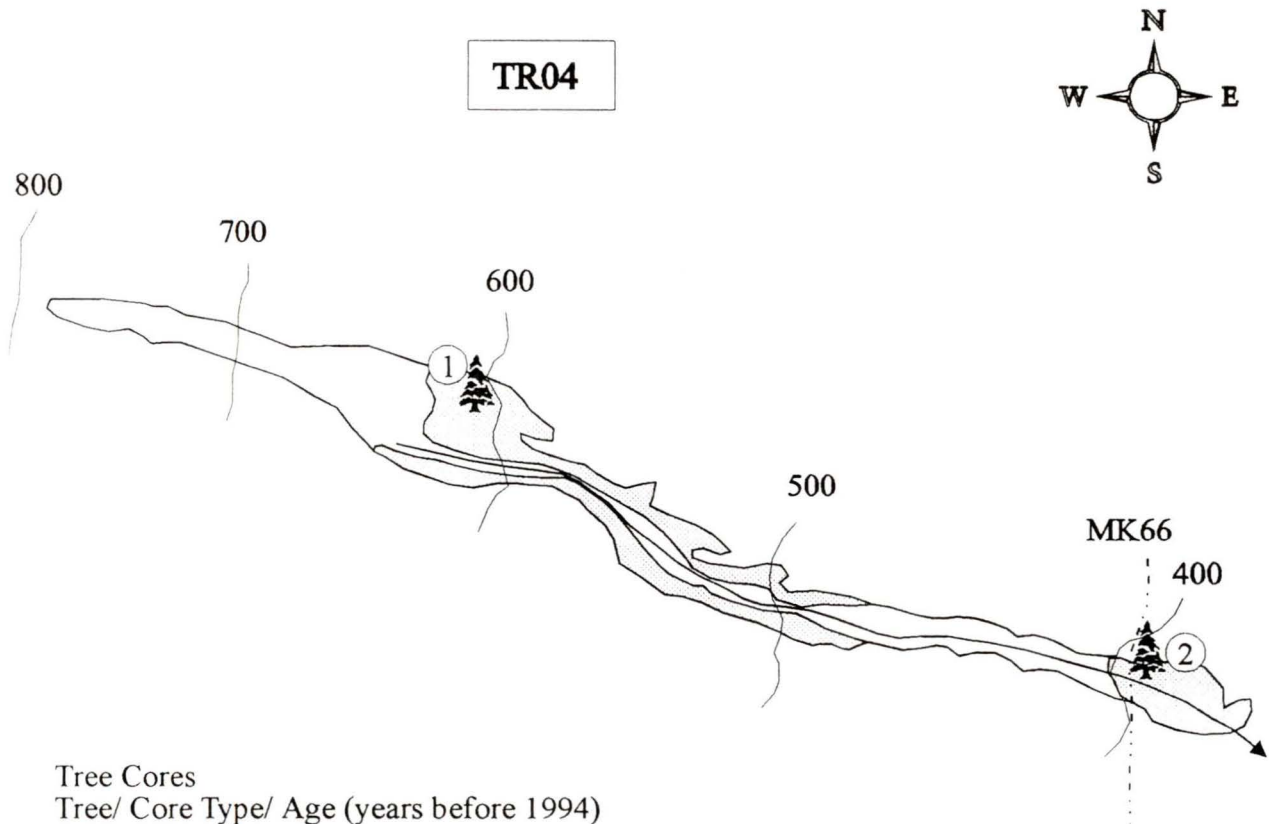

Tree Cores  
 Tree/ Core Type/ Age (years before 1994)

1. 1 Hemlock/ Minimum/ 8
2. 1 Alder/ Minimum/ 8  
 2 Hemlock/ Scar, Peripheral/ 9, 9

Scale = 1:5,000

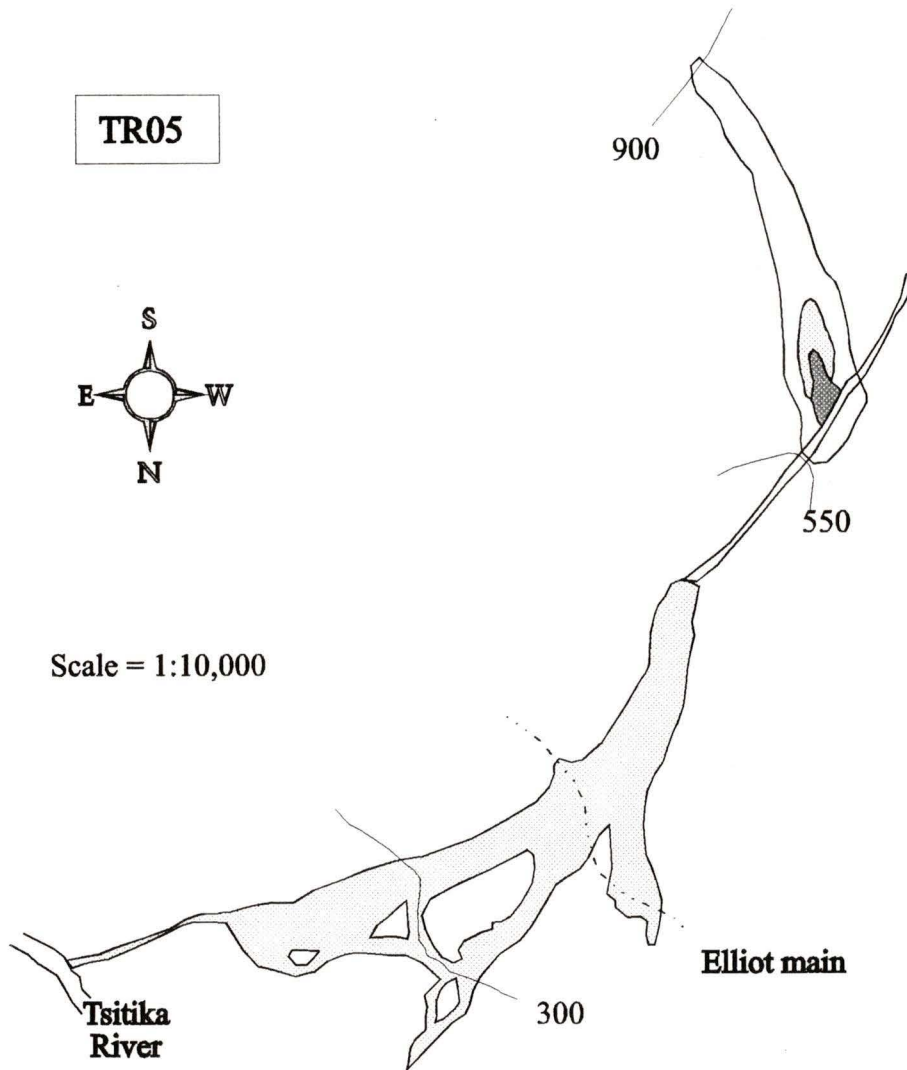

Anecdotal evidence records this event as occurring in 1990. It is on 1994 air photos, and absent on 1987 air photos.

Tree Cores  
Tree/ Core Type/ Age (years before 1994)

1. 2 Alder/ Minimum/ 37,35
2. 2 Alder/ Minimum, Scar/ 26, 7
3. 1 Hemlock/ Minimum/ 23
4. 1 Hemlock/ Minimum/ 17
5. 2 Alder/ Minimum, Scar/ 7, 4
6. 1 Alder/ Minimum/ 4

Other evidence: Landslide present on 1953  
air photographs.

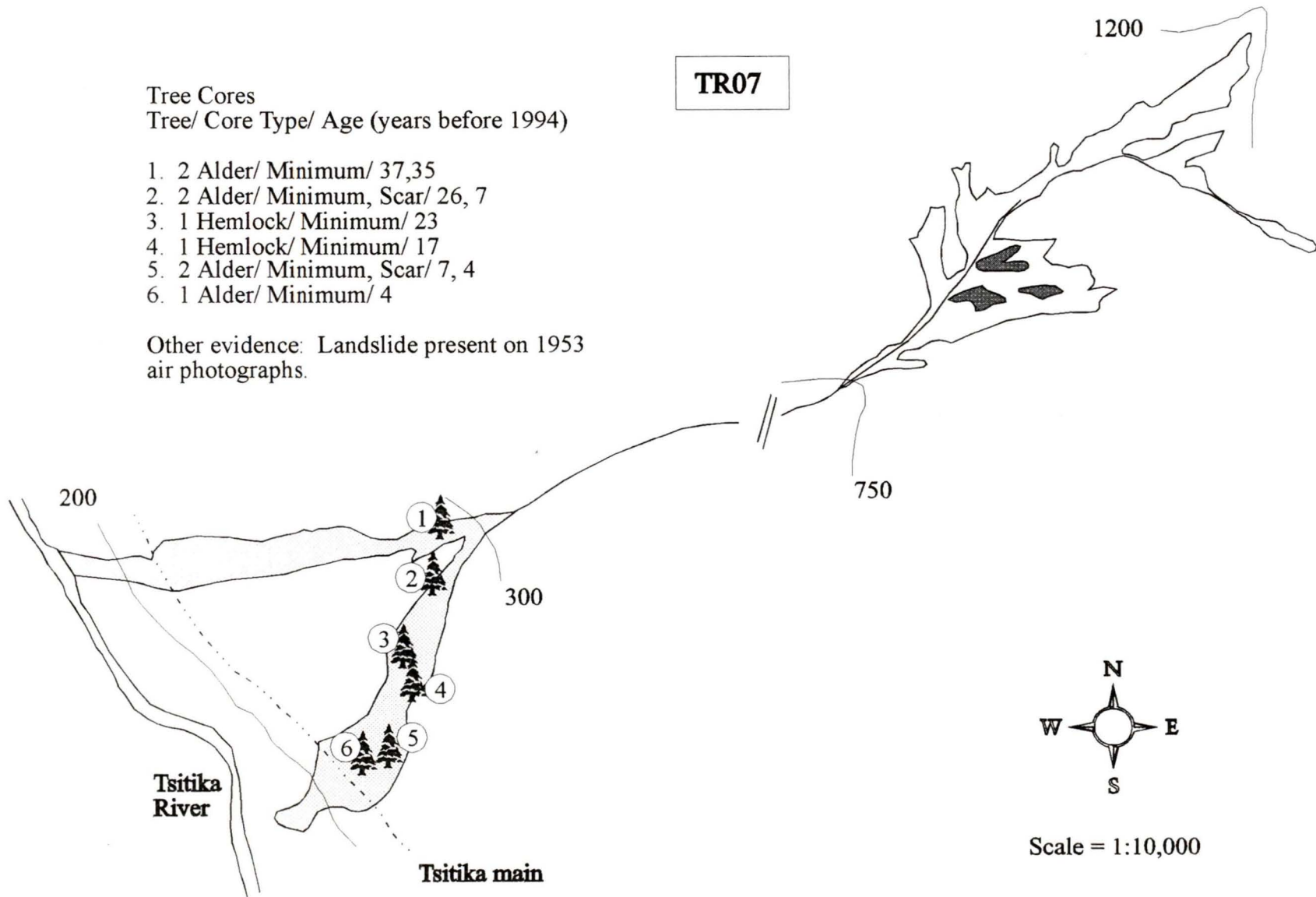

**RC01**

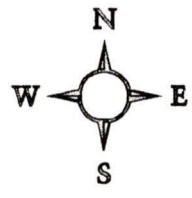
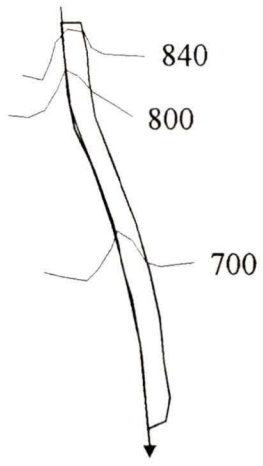

\*No deposit information available for RC01.

**RC03**

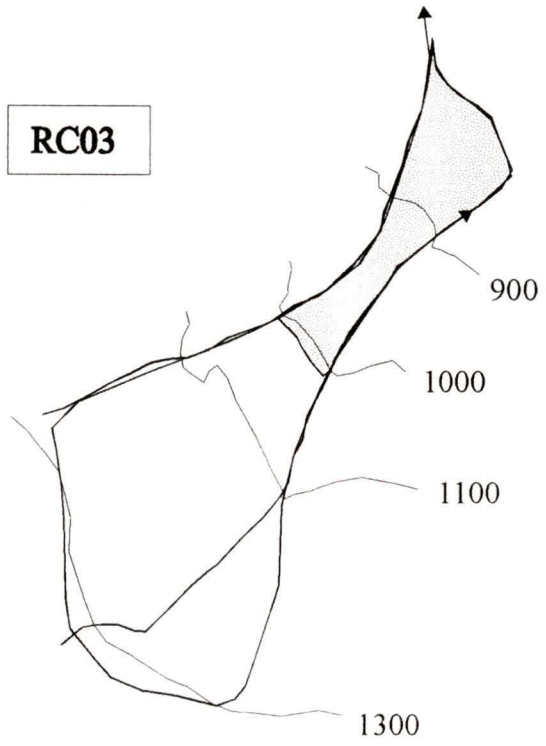

Scale = 1:10,000

**SC03**

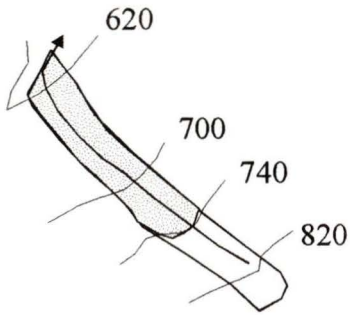

**SC05**

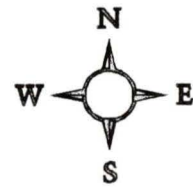
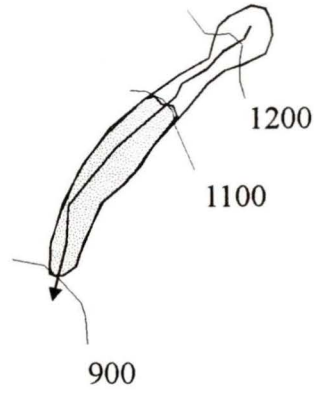

**TH05**

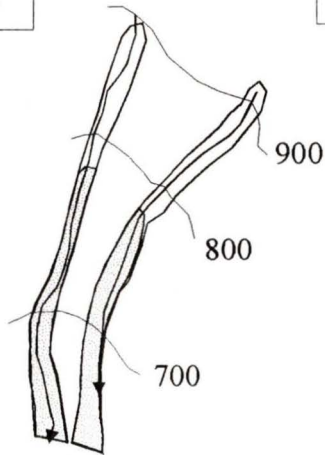

**TH06**

Scale = 1:10,000

\*Deposit locations for landslides derived from air photographs.

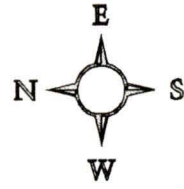

**TR02**

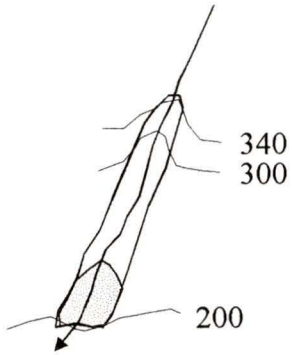

**TR03**

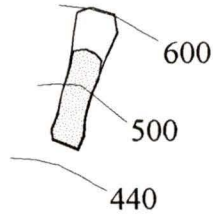

**TR06**

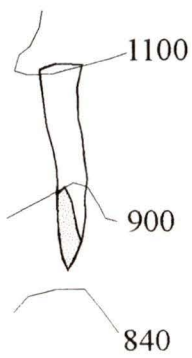

**TR08**

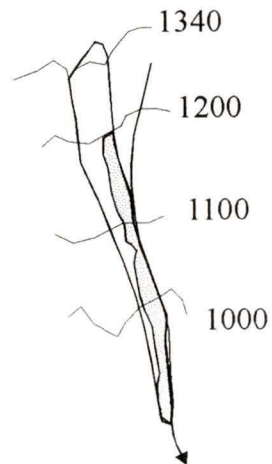

Scale = 1:10,000

\*Deposit information derived from air photographs except for TR02.

## VITA

Surname: Guthrie

Given Names: Richard Hamilton III

Place of Birth: St. Jean, Quebec, Canada

### Educational Institutions Attended:

University of Calgary 1987 to 1992

### Degrees Awarded:

B.Sc. (Honours) University of Victoria 1992

### Honours and Awards:

University of Victoria graduate and teaching grants 1993 to 1997

### Publications:

Chung, C., Bobrowsky, P., Guthrie, R.H., and Van der Flier-Keller, E. 1997. Quantitative predictive models for landslide hazard mapping, northern Vancouver Island, British Columbia, Canada. Geological Association of Canada/Mineralogical Association of Canada annual meeting, Program and Abstracts, v. 22, p. A-26.

Guthrie, R.H. (in press). The characterization and dating of landslides in the Schmidt Creek and Tsitika River watersheds; Northern Vancouver Island, British Columbia. Ministry of Forests Land Management Report.

Guthrie, R.H. 1995. Characterizing and dating mass movements in the Tsitika watershed, Vancouver Island, British Columbia. Geological Association of Canada/Mineralogical Association of Canada annual meeting, Program and Abstracts, v. 20, p. A40.

Guthrie, R.H. 1995. Mass Movements in the Tsitika Watershed, Vancouver Island, British Columbia. Western Inter-University Geological Conference, Program and Abstracts.

Guthrie, R.H. and Van der Flier-Keller, E. 1997. The contribution of underlying geology to the occurrence of landslides on Vancouver Island, British Columbia. Geological Association of Canada/Mineralogical Association of Canada annual meeting, Program and Abstracts, v. 22, p. A-60.

Guthrie, R.H. and Van der Flier-Keller, E. 1997. The use and resolution of dendrochronology as a dating tool on landslides. Canadian Quaternary Association 8th biennial meeting, Program and Abstracts, p. 29.

PARTIAL COPYRIGHT LICENSE

I hereby grant the right to lend my thesis to users of the University of Victoria Library, and to make single copies only for such users or in response to a request from the Library of any other university, or similar institution, on its behalf or for one of its users. I further agree that permission for extensive copying of this thesis for scholarly purposes may be granted by me or a member of the University designated by me. It is understood that copying or publication of this thesis for financial gain shall not be allowed without my written permission.

Title of Thesis:

The characterization and dating of landslides in the Schmidt Creek and Tsitika River watersheds; Northern Vancouver Island, British Columbia.

Author



Rick Guthrie  
August 21, 1997

Johnstone Strait

126°20' W

50°28' N

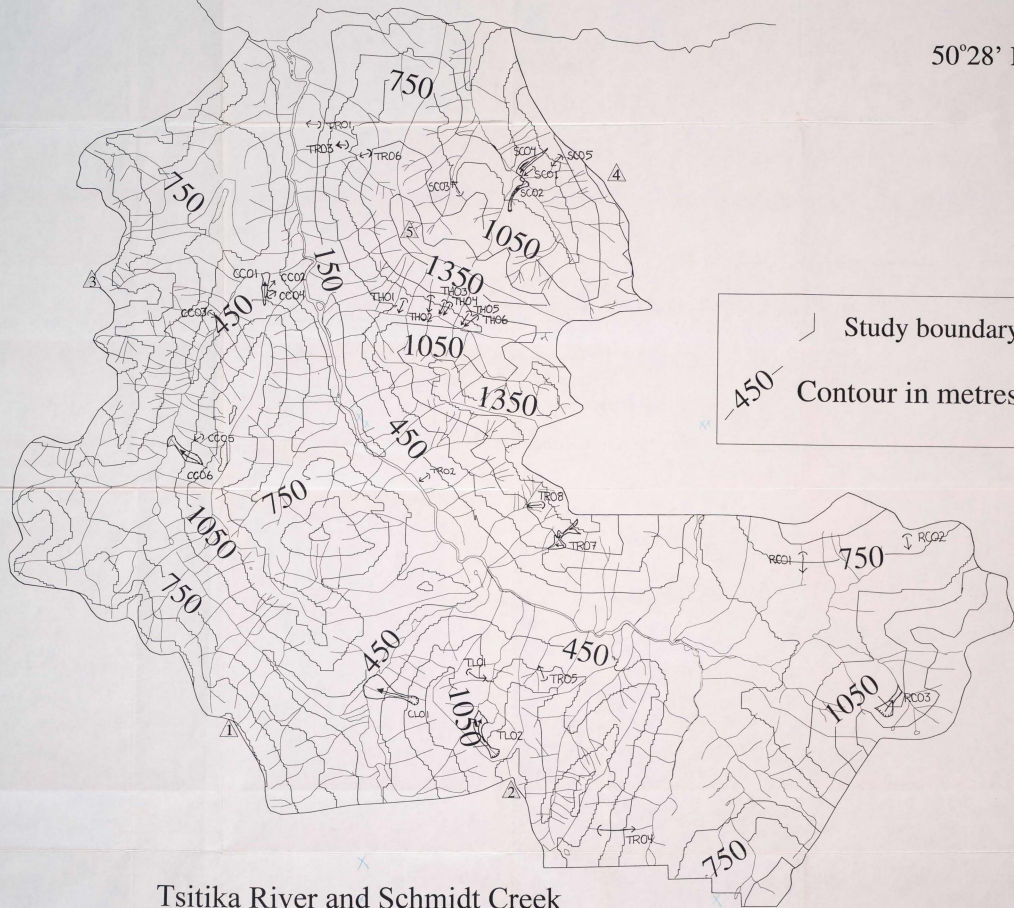

Tsitika River and Schmidt Creek  
Landslide Location Map

50°16' N

126°37' W



Landslide symbols

CC02

Landslide numbers



Mount Ashwood



Mount Elliott



Tsitika Mountain



Mount Peel



Mount Derby

