Faculty of Science

Faculty Publications

This is a post-review version of the following article:

Mechanism and equivalent circuits in electrochemical impedance spectroscopy

David A. Harrington, P. van den Driessche

September 2011

The final published version of this article can be found at:

<https://doi.org/10.1016/j.electacta.2011.01.067>

Citation for this paper:

Harrington, D.A. & Driessche, P. (2011). Mechanism and equivalent circuits in electrochemical impedance spectroscopy. *Electrochimica Acta*, 56(23), 8005-8013.

<https://doi.org/10.1016/j.electacta.2011.01.067>

© 2011. This manuscript version is made available under the CC-BY-NC-ND 4.0 license
<http://creativecommons.org/licenses/by-nc-nd/4.0/>

Mechanism and equivalent circuits in electrochemical impedance spectroscopy

David A. Harrington^{*,a}, P. van den Driessche^b

^a*Department of Chemistry, University of Victoria, Victoria, British Columbia, V8W 3V6, Canada.*

^b*Department of Mathematics and Statistics, University of Victoria, Victoria, British Columbia, V8W 3R4, Canada.*

Abstract

The utility and limitations of using equivalent circuits to analyse electrochemical impedance spectroscopy (EIS) data for electrochemical reaction mechanism are reviewed. The difficulty of assigning physical meaning to elements is discussed. The utility of equivalent circuits as measurement models is emphasized, and ways to use them to find mechanistic information are discussed. The rules about which mechanisms can show inductive behaviour are of interest, since this is a visually obvious feature. We review our previous rules for mechanisms that can show inductive behavior, and show that inductive behaviour is more common for mechanisms with two adsorbed species. We discuss two variations of a simple cycle mechanism ($A \rightarrow B \rightarrow C \rightarrow A$) in more detail.

The interpretation of the charge-transfer resistance and the polarization resistance has some subtleties. Transfer coefficients extracted from Tafel plots of steady-state current-potential measurements are often used to determine where in the mechanism the rate-determining step is. We show that transfer coefficients from Tafel plots of the charge-transfer resistance do not have the same mechanistic significance. The polarization resistance is simply related to the slope of the polarization curve. We discuss the validity of this relationship and its utility in interpreting spectra.

Key words: equivalent circuit, mechanism, charge-transfer resistance,

*Corresponding author. Tel.: +1-250-7217166

Email addresses: dharr@uvic.ca (David A. Harrington), pvdd@math.uvic.ca (P. van den Driessche)

1. Introduction

Electrochemical Impedance Spectroscopy (EIS) is widely used as a mechanistic tool, i.e., as a technique to deduce the constituent elementary reaction steps of an overall electrochemical reaction, and to extract the numerical values of the rate constants and other kinetic parameters characterizing those reaction steps. It is possible to proceed toward this goal without using equivalent circuits: a mechanism is proposed, the impedance corresponding to this mechanism is derived as a function of the kinetic parameters, and the data are then compared with this prediction. The way to derive the impedances for a given mechanism has been known from the earliest days of EIS, and has been reviewed, e.g., [1, 2]. It has been generalized for arbitrary mechanistic schemes [3–6], and software has been developed for automation, e.g., CASIDIE [7], PIRoDE [8, 9]. The comparison with the data may be visual, through comparison of plots of the derived impedance with the data, though occasionally more rigorous least squares fitting to the data has been used, e.g., [10, 11].

Despite this, the use of equivalent circuits is entrenched in EIS. The easy availability of commercial software to automate the least-squares fitting of data to circuits is likely the main reason for this. However, the interpretation of the elements, and the utility of equivalent circuits in deducing mechanistic information is controversial. There appears to be a dichotomy in the field: some study mechanisms and do not use equivalent circuits; others use equivalent circuits but do not interpret the parameters mechanistically. There is a middle ground in which fitting to equivalent circuits is a first step in mechanistic analysis, and this forms the topic of this paper. We review here some key issues about interpretation of equivalent circuit elements for reaction mechanisms. Many of these are known to the practitioners in the field, but they have not all become well known to the average EIS user and are the cause of common misconceptions. Since the focus is on interpretation, it is outside the scope of this article to discuss the fitting process at the level of data manipulation; the assumption is that the reader understands how to find and fit an equivalent circuit to real impedance data.

We begin by making some observations about the difficulty of finding equivalent circuits that are simply related to the underlying mechanism, and

show that except for some isolated cases, circuit structure is not obviously related to mechanism. The related issue of non-uniqueness is touched upon, but has been well discussed previously [12]. We suggest that for extracting kinetic parameters, the ladder circuit has benefits. Aspects of the underlying mechanism can be deduced from the numbers of capacitances, inductors and resistors, the presence or absence of a dc path, and the presence or absence of inductive behavior. These aspects aid in the selection of candidate mechanisms. We illustrate these ideas for a simple cycle mechanism with two adsorbed intermediates, and derive a criterion for inductive behavior for it. A special case of this mechanism is used to show that a circuit that is blocking to dc need not correspond to a mechanism with zero reaction rate.

We finish with some observations on the nature of inductive behavior and the meaning of the charge-transfer resistance, R_{ct} , and the polarization resistance, R_p . In particular, we show that the Tafel plots of the charge-transfer resistance (potential vs $-\log R_{ct}$) are not useful for distinguishing reaction mechanisms.

2. Results and discussion

2.1. Uses and limitations of equivalent circuits

2.1.1. Correspondence between circuits and physical processes

The simplest equivalent circuit, Fig 1a (henceforth "circuit 1a") demonstrates the desirable correspondence between elements of a circuit and physical processes. This circuit applies for example for reaction (1) where mass transport of reactant A and product A^+ maintains constant concentrations at the interface, and there is no complication due to adsorption. The potentials at points X and Y represent the potentials on the metal and solution sides of the double layer, and the potential difference between these points drives the reaction modeled by the charge-transfer resistance R_{ct} . Point Z represents the potential at the reference electrode. The physical significances of each of the three circuit elements are clear and generally accepted. Their values separately characterize the interface (C_{dl}), the reaction (R_{ct}) and the solution (R_s).



Circuit 1b can equally well fit data that fits circuit 1a, but the parameters here are mixtures of the basic parameters of the model, e.g., $R_1 = R_{ct} + R_s$

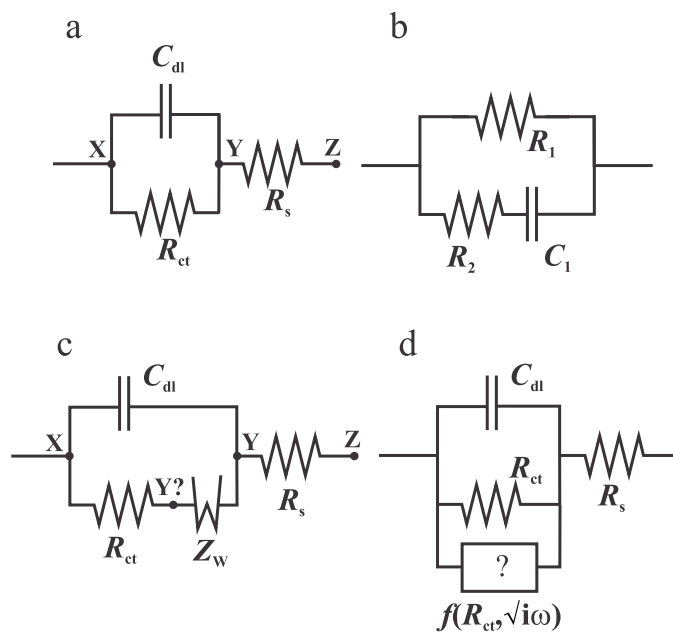

Figure 1: Some simple equivalent circuits. (a) for a simple redox reaction, (b) equivalent form to (a), (c) Randles circuit for redox reaction with diffusion, (d) alternate form for (c).

mixes reaction rate parameters with solution parameters. Additionally, no point in the circuit corresponds to the point Y just outside the double layer. This is evidently not a good choice. However, one needs only add diffusion of one or both solution species in reaction (1) to find that the relevant model, the classical Randles circuit (circuit 1c), suffers the same problem. The point Y representing the solution side of the double layer is not clear – it seems that the potential across the double layer no longer drives the charge transfer. An attempt to solve this by having the charge-transfer resistance parallel to the double-layer capacitance (circuit 1d), leads to a new boxed "diffusion" element. This unfortunately does not solve the problem, because the boxed element depends on kinetic parameters as well as diffusion parameters. This is no better or worse than the fact that the Warburg element representing diffusion is characterized by the parameter σ which contains both diffusion and reaction parameters: σ is the product of R_{ct} and solution parameters. The point here is that there is rarely a simple correspondence between circuit elements and reaction steps or physical processes. Nonetheless, this Randles circuit is acceptable as an equivalent circuit because we can use it to extract parameters relating to the physical processes. As is generally true, individual physical parameters are not measurable, but only certain combinations of them are measurable. Parameters from different processes (kinetics and diffusion in this case) are typically mixed.

2.1.2. Non-uniqueness and fitting choices

Accepting that coupling of parameters is inevitable, can we minimize the complexity of this coupling? How can equivalent circuits be useful? We discuss this general issue and then present a specific mechanism to emphasize these points. We assume henceforth that the underlying mechanisms have fast mass transport and possibly adsorption. We omit the solution resistance from circuits and equations. This means that the circuit will be composed of resistors, capacitors and inductors, and idealised Nyquist (complex plane) plots of the impedance will consist of semicircular arcs above the real axis (capacitive) or below (inductive). As a practical matter, these features may not always be well resolved. Consider an impedance spectrum showing three capacitive semicircles that has zero impedance at infinite frequency and is resistive at zero frequency (Fig. 2a). This will fit to an RC circuit with three capacitors and three resistors and Figs. 2b-d give three possibilities, which

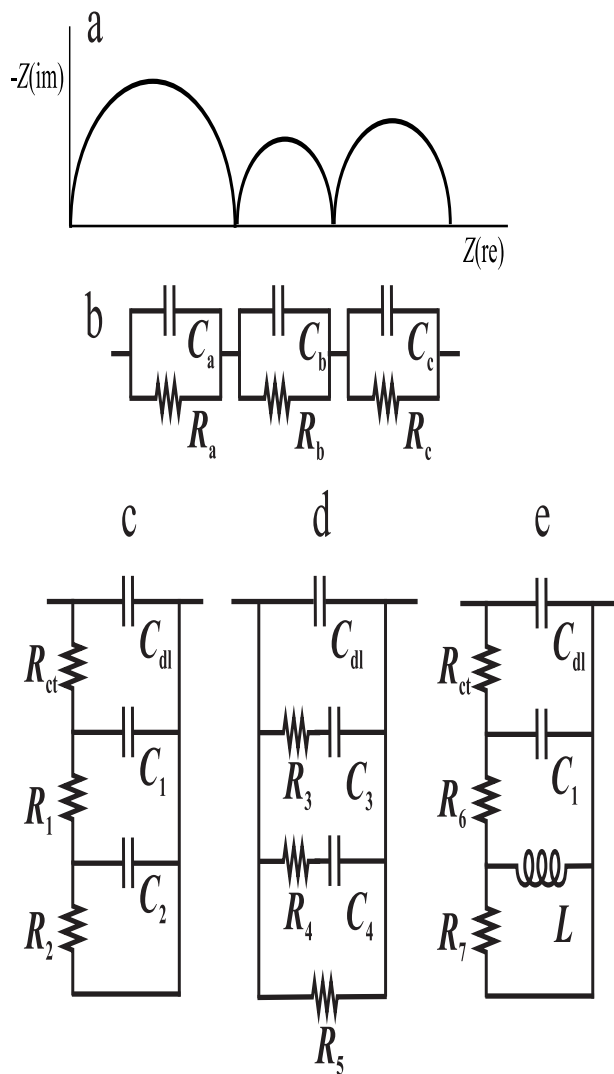

Figure 2: Some equivalent circuits for a reaction mechanism. (a) a schematic impedance spectrum, (b), (c) and (d) can all fit this same impedance for particular element values, (e) is an inductive form for the same mechanism at a different potential. The mechanism of reactions (7) - (9) is an example of a mechanism with these circuits.

correspond to the impedance expressions in Eqs. (2) - (4),

$$Z = \frac{1}{sC_a + \frac{1}{R_a}} + \frac{1}{sC_b + \frac{1}{R_b}} + \frac{1}{sC_c + \frac{1}{R_c}} \quad (2)$$

$$= \frac{1}{sC_{dl} + \frac{1}{R_{ct} + \frac{1}{sC_1 + \frac{1}{R_1 + \frac{1}{sC_2 + \frac{1}{R_2}}}}} \quad (3)$$

$$= \left[sC_{dl} + \frac{1}{R_3 + \frac{1}{sC_3}} + \frac{1}{R_4 + \frac{1}{sC_4}} + \frac{1}{R_5} \right]^{-1} \quad (4)$$

$$= \frac{s^2 + a_1s + a_2}{C_{dl}(s^3 + b_1s^2 + b_2s + b_3)} \quad (5)$$

$$= \frac{(s - \alpha_1)(s - \alpha_2)}{C_{dl}(s - \beta_1)(s - \beta_2)(s - \beta_3)} \quad (6)$$

where $s = i\omega$, and the other symbols represent real parameters that may be extracted from the data, six parameters for each form of the impedance. Other combinations of three capacitors and three resistors will be equivalent if replacing the capacitors with open circuits (low frequency limit) leaves a resistance (there is a dc path), and replacing the capacitors with short circuits (high frequency limit) leaves a combination with zero impedance (equivalent to a short circuit)¹. Eqs. (2) - (4) are equivalent forms of the same impedance (same at all frequencies). They all simplify to Eq. (5), and factoring the numerator and denominator leads to the pole-zero form, Eq. (6). Circuit theory [13] shows that $\beta_1 < \alpha_1 < \beta_2 < \alpha_2 < \beta_3 < 0$ (all real) and that $a_1, a_2, b_1, b_2,$ and b_3 are all positive.

Confronted with some experimental data, the first question would be to ask whether or not *any* of these fit the data, or are the data fitted by another form that is not equivalent, e.g., a circuit with a different number of elements or one that blocks dc - these are not equivalent to Eq. (5). For this, success or failure of fitting any of these *measurement models* establishes whether or not the impedance is of this essential form. This is analogous to first asking whether some data fit a straight line or a quadratic; for the purposes

¹Some common sense needs to be applied to use this equivalence rule, e.g., two resistors in series cannot be distinguished from a single resistor and so count only as one, all pieces need to be connected to give a two-terminal circuit.

of deciding this, any of the equivalent forms of a straight line will do, e.g., $y = mx + c$ or $(y - y_0)/(x - x_0) = m$. The utility of equivalent circuits as measurement models, and some reasons for choosing particular circuits or impedance expressions to fit data to have been discussed previously by Zoltowski [14, 15]. The choice depends on the purpose for which the data are collected, and the tools available to the researcher. In the study of oscillating systems, the nature of the poles ($\beta_1, \beta_2, \beta_3$) and zeroes (α_1, α_2) relate most directly to the stability of the system and give information about incipient oscillations without having to know the mechanism; in this case Eq. (6) is the preferred form. As shown in A, the coefficients of the rational function form, Eq. (5) are most simply related to rate constants: they are sums of products of rate constants. If determination of rate constants is the primary objective (as we typically assume), then this is the preferred form. However, most commercial software does not fit to forms (5) or (6), but to one of the equivalent circuit forms (2) - (4).

Given this restriction, which of the equivalent circuits is preferred? Circuit 2b has the advantage that the three $R_i C_i$ parts in series correspond most directly to the three observed semicircles, e.g., their diameters are R_a, R_b and R_c . This might be a good form for selecting initial parameter estimates to feed to a non-linear fitting routine, but from an interpretive point of view it has no advantages. The double-layer capacitance is mixed into all the elements, e.g., $C_{dl}^{-1} = C_a^{-1} + C_b^{-1} + C_c^{-1}$. The parameters most easily extracted from this circuit are the poles $\beta_1, \beta_2, \beta_3 = -1/C_a R_a, -1/C_b R_b, -1/C_c R_c$. Similarly, fits to circuit 2d easily allow the extraction of the zeroes $\alpha_1, \alpha_2 = -1/C_3 R_3, -1/C_4 R_4$. However, the poles and zeroes are the roots of polynomials and are related to the coefficients in a very complicated way (with no closed form possible for quintics or higher). Therefore circuits 2b and 2d are not suitable for mechanistic work. They have an additional disadvantage that there is some ambiguity in defining circuit branches, e.g., the exchanges $C_a \longleftrightarrow C_b$ and $R_a \longleftrightarrow R_b$ lead to the same impedance, and this can cause the fitting routine to have some convergence difficulties. The capacitors and resistors of the ladder circuit 2c are easily converted to the coefficients a_1, a_2, b_1, b_2, b_3 and thence to the kinetic parameters (or its capacitors and resistors may be directly converted to the kinetic parameters). For this reason it is preferred for mechanistic work. It might be argued that all forms are equivalent, because the parameters from one may be converted to parameters of the another by solving some simultaneous equations. Although this is true for ideal data, in practice error propagation quickly degrades the reliability

of parameters, and it is best to fit directly to the most relevant form.

2.1.3. Matching mechanisms to circuits - an example

Consider the simple sequential reaction

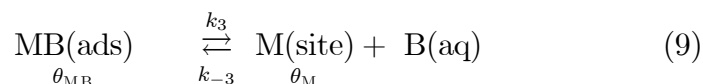
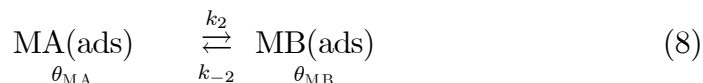
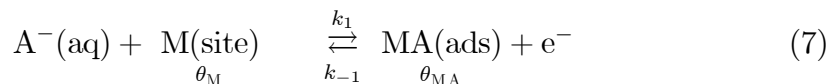

Here M(site) is a reaction site on a metal surface, MA means A adsorbed on a surface M atom, and MB is a structurally rearranged version of MA. We suppose mass transport is fast, so that the surface concentrations of A⁻(aq) and B(aq) are constant and can be subsumed into the rate constants. These species are referred to as "external" or "static", are omitted hereafter, and should be considered invisible in calculations of the number of independent reactions given below. Omitting them and the electrons shows the basic cyclic structure of this mechanism, M→MA→MB→M. We assume Langmuir kinetics for the adsorbed species. The kinetics of this mechanism (and other ones with the same cycle) are

$$v_1 = k_1\theta_{\text{M}} - k_{-1}\theta_{\text{MA}} \quad (10)$$

$$v_2 = k_2\theta_{\text{MA}} - k_{-2}\theta_{\text{MB}} \quad (11)$$

$$v_3 = k_3\theta_{\text{MB}} - k_{-3}\theta_{\text{M}} \quad (12)$$

with the rate constants k_1 and k_{-1} potential dependent in the usual way. The surface coverages obey the constraint $\theta_{\text{M}} + \theta_{\text{MA}} + \theta_{\text{MB}} = 1$. The stoichiometric matrix (Eq. 13) contains the stoichiometric coefficients, e.g., column 1 reflects the fact that in step 1 one electron is produced, one atom of MA is produced and one atom of M is lost.

$$\mathbf{N} = \begin{matrix} & \begin{matrix} 1 & 2 & 3 \end{matrix} \\ \begin{bmatrix} 1 & 0 & 0 \\ 1 & -1 & 0 \\ 0 & 1 & -1 \\ -1 & 0 & 1 \end{bmatrix} & \begin{matrix} \text{e}^- \\ \text{MA} \\ \text{MB} \\ \text{M} \end{matrix} \end{matrix} \quad (13)$$

If electrons are removed from this mechanism, then step 3 can be written as a combination of steps 1 and 2 in the sense of Hess's law (step 1 + step 2 = -step 3):



That is, only two of the reactions are independent, we denote this by $I' = 2$. Once the electron is added back in, no reaction can be written as a linear combination of others, so all three reactions are independent and we write $I = 3$. We define a parameter $X = 2(I - I')$, which may be either zero or two. Here $X = 2$. Chemically, $X = 2$ means that it is possible to construct a reaction that includes both external species and electrons: the overall reaction $\text{A}^- \rightarrow \text{B} + \text{e}^-$ satisfies this criterion for this mechanism. It also means that the equivalent circuit will have a dc path; this is related to the fact that current flows at steady state.

The significance of the quantities I' , I and X in terms of the rank of the stoichiometric matrix \mathbf{N} is given in A. There, the impedance is calculated from the rate equations. The kinetic information is collected in a matrix \mathbf{Q} and its submatrix $\mathbf{Q}(1)$, and the fact that these matrices generally have the same ranks as matrices \mathbf{N} and $\mathbf{N}(1)$ respectively, means that some information about the equivalent circuit is available by knowing only the stoichiometry, or \mathbf{N} . The circuit will contain I resistors (excluding the solution resistance) and $I + 1 - X/2$ capacitors or inductors (including the double-layer capacitance) [6]. Here there will be 3 resistors and 3 capacitors or inductors. Together with the fact that there is a dc path ($X = 2$), we conclude that the equivalent circuits in Fig 2 are possibilities and the impedance is that in Eqs. (2) - (6). As already noted, circuit 2c is preferred for parameter extraction. Other mechanisms with $I = 3$ and $X = 2$ will also have these circuits. All mechanisms have RC circuits at the equilibrium potential [6], so the observation of inductive behaviour at some other potentials may be a qualitative clue to the mechanism. A shows that this mechanism will be inductive (circuit 2c) when

$$(a^2 + b^2 + c^2) > (a - b)^2 + (b - c)^2 + (c - a)^2 \quad (15)$$

where $a = k_1 - k_{-2}$, $b = k_2 - k_{-3}$, $c = k_3 - k_{-1}$. By inductive, we mean that an equivalent circuit with positive elements, one or more of which is an inductor, fits the experimental data. This does not necessarily imply that

the impedance will go below the real axis in a Nyquist plot. That depends on the inductance being large enough to dominate.

An obvious question is whether there is a modification of this cyclic mechanism for which $X = 0$, i.e., $I' = I$. We have already seen that stripped of external species and electrons, there are two independent reactions so that $I' = 2$. We need to add electrons back in such a way that there are still only two independent reactions; we can achieve this if we retain the relationship step 1 + step 2 = -step 3. One way to do this is:

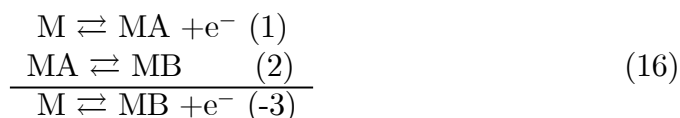

Adding in external species to balance the reactions we find that a sensible example is the mechanism of Eqs. (17)-(19) with HA, HB and H^+ as external species.

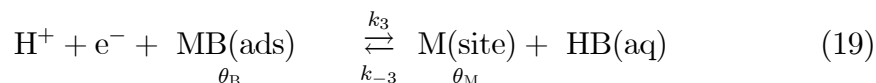
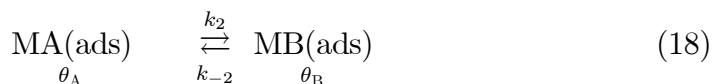
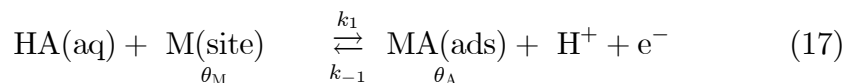

The stoichiometric matrix is

$$\mathbf{N} = \begin{array}{ccc} & \begin{matrix} 1 & 2 & 3 \end{matrix} & \\ \begin{bmatrix} 1 & 0 & -1 \\ 1 & -1 & 0 \\ 0 & 1 & -1 \\ -1 & 0 & 1 \end{bmatrix} & \begin{matrix} \text{e}^- \\ \text{MA} \\ \text{MB} \\ \text{M} \end{matrix} & \end{array} \quad (20)$$

The electron row is a linear combination of the other rows. The surface catalyzes the overall reaction, which is the isomerization $\text{HA} \rightarrow \text{HB}$. At steady state, each of the three steps proceeds at the same rate, and the current density is zero. This therefore is an interesting case, where the reaction proceeds at a finite rate but the steady-state current is zero. There will be a transient current that will enable the impedance to be measured. Here $X = 2(I - I') = 2(2 - 2) = 0$; from the chemical point of view $X = 0$

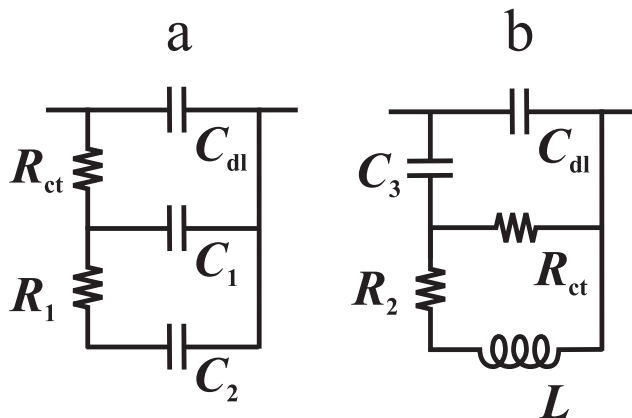

Figure 3: Equivalent circuits for the mechanism of reactions (17) - (19). (a) ladder form of RC circuit, (b) inductive circuit when condition (15) applies.

means that it is impossible to construct a reaction including the electrons and the external species. The overall reaction does not work here because electrons must be included. Since both HA and HB have the same oxidation state, no acceptable reaction can be found. From the equivalent circuit point of view, $X = 0$ means that there is no dc path: the behavior is blocking at low frequencies. With $I = 2$ and $X = 0$, there are $I = 2$ resistors and $I + 1 - X/2 = 3$ capacitors or inductors, see Fig. 3.

This example emphasizes that blocking behavior or the absence of a dc path through the circuit implies lack of current flow and not necessarily a lack of reaction. Electrons play a special role in equivalent circuits, and current is not just a proxy for reaction rate. This mechanism can show inductive behavior because it has the same basic cyclic structure that gives the criterion of Eq. (15), which also applies here. Note that although circuit 2c without R_2 is the correct RC circuit, circuit 2e without R_7 is not blocking at d.c., and so cannot be the correct inductive form. A detailed analysis shows that circuit 3b is appropriate.

2.1.4. Analysis strategy

The above considerations lead to the following strategy for using equivalent circuits to analyse the impedance of reaction mechanisms involving adsorption but uncomplicated by mass transport. The objective of the analysis is assumed to be deduction of the steps in the mechanism and estimation of

the rate constants.

1. Use any tools to fit to an equivalent circuit consisting of capacitors, inductors and resistors. If the low-frequency limit is resistive (intercept is on the real axis), then the circuit will have a dc path; if the impedance tends to infinity at low frequency, the circuit will be blocking at dc. A successful fit to any such circuit with positive element values automatically satisfies the Kramers-Kronig relationships and validates the data. For blocking behavior at dc, take $X = 0$ and for non-blocking behavior, take $X = 2$. The number of resistors (not counting the solution resistance) gives the parameter I and the number of capacitors and inductors is $I + 1 - X/2$.
2. Use the values of I and X to narrow down candidate reaction mechanisms. The number of independent reactions including electrons must be I and the number of independent reactions with the electrons omitted must be $I - X/2$. The external species (solution species with fast mass transport) are omitted in this calculation. A reaction between external species and electrons is possible for $X = 2$ but not for $X = 0$. (Our rules here are in general compatible with the rule that each additional adsorbed species adds a relaxation or "loop" [1, 16], because a reaction that introduces a new adsorbed species must be independent of the other reactions.) The rules (below) about which mechanisms can show inductive behavior can assist in deciding upon candidate mechanisms.
3. If the ladder circuit was not fitted directly in step 1, then fit to the ladder circuit (generalized form of circuit 2c (non-blocking) or circuit 3a (blocking)) with the same number of resistors as the circuit in step 1 and the same number of capacitors as the total number of capacitors and inductors in the circuit in step 1. For inductive behaviour, it is simpler to use capacitors and allow the circuit elements to become negative than to decide where in the circuit the inductors should be. An exception to the rule that the kinetic parameters are most simply related to the ladder form occurs for mechanisms with a single adsorbed species ($I = 2, X = 2$) for which an inductive form is optimum [17].
4. Fit the impedance to the ladder circuit over a wide range of potentials to find the potential dependence of the circuit elements. Note that potentials at which the circuit has the most elements should be used to deduce the mechanism in step 2, because for practical reasons some

features may not be resolved under all conditions.

5. The potential dependence of the circuit elements is used to decide between the remaining candidate mechanisms. This requires a kinetic analysis such as that in A. Briefly, after using the kinetic equations to find the impedance in the rational function form, Eq. (5), a successive division algorithm of circuit theory is used to find the element values in terms of the rate constants, see p. 79 in [13]. Analysis of the potential dependence of the ladder circuit elements is simplest for those elements closest to the double-layer capacitance, so these should be used first in an analysis. For example, for the mechanism of reactions (7) - (9), C_1 is a simple function of rate parameters for reaction step 1 alone (Eq. (43)). The double-layer capacitance is found directly, then k_e from R_{ct} , and then $k_1 + k_{-1}$ from C_1 ; this gives maximum information about step 1. Further steps in the analysis could include fits to other forms of the impedance or directly to a proposed kinetic scheme.

2.2. Meaning of circuit elements

Despite the caution above that individual circuit elements rarely have direct physical significance, some observations about the meaning of elements are possible. The significance of C_{dl} is well known, and the other capacitors are usually associated with adsorption. Despite being referred to as adsorption pseudocapacitances, they do not have the same significance as the steady-state pseudo capacitance and cannot be used to simply extract coverages [17]. An example has been given where strong coupling to mass transport removes capacitors and leads to only resistors and Warburg elements even though adsorption is present (Fig. 2 in ref. [4]). The charge transfer resistance, R_{ct} , and the polarization resistance, R_p have fairly simple interpretations, though there are some subtleties that merit discussion.

2.2.1. The polarization resistance

As determined from the impedance spectrum, the polarization resistance, R_p , is the limit of the impedance at zero frequency (first equality in Eq. (21), see Fig. 4 for examples).

$$R_p = \lim_{\omega \rightarrow 0} Z(\omega) = \left(\frac{dj_{ss}}{dE} \right)^{-1} \quad (21)$$

where E is the potential and j_{ss} is the steady-state current density at that

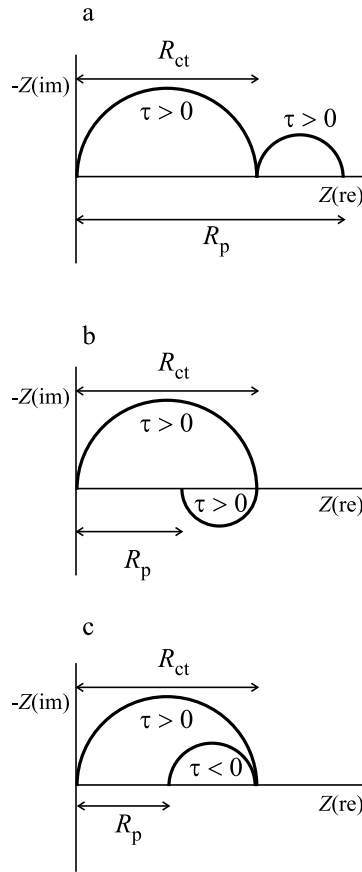

Figure 4: Resistances and time constants for some impedances with two semicircles. (a) capacitive low-frequency relaxation, (b) inductive low-frequency relaxation, (c) low-frequency relaxation with positive capacitance and negative resistance.

potential². If the equivalent circuit is available, rather than the impedance spectrum, then R_p is found by replacing the capacitors with open circuits, the inductors with short circuits and calculating the equivalent resistance, e.g., for circuits 2b-e it is $R_a + R_b + R_c$, $R_{ct} + R_1 + R_2$, R_5 , and $R_{ct} + R_6$ respectively. Early in the history of impedance theory, it became "clear, whatever the complexity that $Z(i\omega \rightarrow 0)$ is equal to $\partial\bar{E}/\partial\bar{I}$ " [1]. That is, the polarization resistance found from the impedance must equal the reciprocal of the slope of the steady-state current-potential curve, Eq. (21) in our notation. This equality of the impedance and steady-state definitions of the polarization resistance was originally shown by use of examples, including those with negative slopes in the polarization curve [18]. In a general formulation of the impedance, Naito et al [19] derived the slope of the polarization curve under a number of stability conditions by evaluating $Z(\omega \rightarrow 0)$ under these conditions, i.e., they assumed (21) was true. This relationship was later generalized for multiple inputs and outputs including non-electrochemical impedances [20], but to our knowledge a proof has not been given. In B, we show that Eq. (21) always holds, provided that the system is stable, though examples show that it has a wider validity.

One practical use of Eq. (21) is to determine if there are missing relaxations at frequencies lower than those measured, as noted by Schuhman [1]. For example, suppose the real impedance is that of Fig. 4b, but only the high-frequency semicircle above the axis were measured. Measurement of the slope of steady-polarization curve gives the R_p shown, and the fact that this is less than the measured intercept (at R_{ct}) indicates that there is a missing relaxation (the inductive loop) at frequencies lower than were measured. In our experience, this is the most useful test to decide whether or not the data has been measured to low enough frequencies.

To rationalize Eq. (21), we begin by noting that the limiting low-frequency behavior must have zero phase, i.e., be resistive, because the applied potential sinusoid is slower than any of the physical processes. All of the oscillations of physical quantities, e.g., surface concentrations are able to "keep up"; there is no phase delay, and the resulting current follows the potential in the same way as it would in a measurement of a steady state polarization curve using

²The polarization resistance is often defined instead as the zero-frequency intercept minus the solution resistance. In that case, the steady-state current potential curve must be likewise corrected for ohmic drop in order for the relationship (21) to hold.

a very slow sweep. Therefore the ratio of changes in current to changes in potential equals the slope of the polarization curve.

2.2.2. The charge transfer resistance

The charge transfer resistance R_{ct} is defined as [21]

$$R_{\text{ct}} = \left(\frac{\partial j_{\text{f}}}{\partial E} \right)_{c_i, \theta_i}^{-1} \quad (22)$$

i.e., it measures the change in faradaic current as the potential across the double layer is changed, while keeping the composition at the surface constant. In contrast to R_{p} where the potential is changed slowly so that the surface condition changes during the perturbation, here the potential is changed rapidly so that the surface condition has no time to change. It is the limit of the faradaic impedance at high frequencies [4]. Therefore, it may be found from an equivalent circuit as the effective resistance in parallel with C_{dl} after replacing inductors with open circuits and capacitors except C_{dl} with short circuits, e.g., it is the parallel combination of R_3 , R_4 and R_5 in circuit 2d. It usually approximates the diameter of the highest frequency semicircle, as indicated in Fig. 4.

In the simple picture of Fig. 1a, increasing the potential increases the potential at X relative to the potential at Y, which promotes current to the right, i.e., an increase in positive (anodic) current. Therefore in this picture, R_{ct} must always be positive. It was emphasized in ref. [21], p. 1851, that R_{ct} for a single reaction would go negative only under extreme conditions. Negative R_{ct} has been proposed to explain the origin of some oscillating mechanisms, but a more detailed analysis by Berthier et al [22] shows that the real R_{ct} is positive in all cases, under a mild set of assumptions, as we propose here. A simple resolution of these apparent inconsistencies is to note that if reactions are fast enough that the composition of the interface can change on the timescale of double-layer charging ($\tau = C_{\text{dl}}R_{\text{s}}$), then it is impossible to measure the true R_{ct} defined by Eq. (22). In this case R_{ct} is so small that another resistive element is measured as an apparent charge-transfer resistance. For example, if in circuit 2c R_1 were negative for some reason and R_{ct} were very small, then C_1 combines in parallel with C_{dl} to give an apparently large double-layer capacitance, and R_1 appears as an apparent negative charge-transfer resistance. Other explanations for apparent negative charge transfer resistances have been given [1, 19].

The defining equation (22) invokes faradaic current and therefore is specific to electron transfer. However, non-faradaic adsorption or structural rearrangements of adsorbed species can lead to a capacitance change and an induced current flow that leads to a similar resistor in an equivalent circuit [23]. For this reason, it is better to think of R_{ct} as representing the dissipation of energy associated with an activation energy, rather than as being specifically associated with electron transfer.

Tafel plots of R_{ct} are not diagnostic of mechanism. In the classic Tafel analysis, the slope of a plot of the overpotential vs the logarithm (base 10) of the steady-state current is used to find the transfer coefficient, $\alpha = (RT \ln 10) / (F \times \text{slope})$. This parameter is diagnostic of where the rate-determining step (rds) occurs in the sequence of elementary reactions in the mechanism. A value close to 1/2 suggests that the first electron transfer is the rds, a value close to unity suggests a chemical rds following a one-electron pre-equilibrium step, etc. [24]. It is common to assume that α_R extracted in the same way from a Tafel plot of R_{ct} , a plot of overpotential vs $-\log R_{ct}$, has the same significance, but we show below that this is not the case.

In view of the discussion above about the meaning of R_{ct} , the state of the interface is frozen as the potential is increased, and the increase in current comes from the change in the electron transfer rate of *all* the electron-transfer steps, regardless of whether they are the rds or a preceding or following step. For example, during the mechanism of (17) - (19), there will be at any time some concentrations of M, MA and MB on the surface. An increase in potential immediately increases the rate of step (17) and decreases the rate of step (19), regardless of the fact that the three steps occur sequentially at a slower time scale. In effect the concept of the rds is not relevant at high enough frequencies that the surface condition is frozen. The expectation is that if all the electron-transfer steps are single-electron transfers with symmetry factors $\beta = 0.5$, then these will all operate in parallel and the slope of a potential-log R_{ct} plot will yield an apparent transfer coefficient $\alpha_R = 0.5$, regardless of which step in the mechanism is rate determining. R_{ct} is a *parallel* combination of the charge-transfer resistances of each step [4, 22], even if these steps are not parallel steps in the mechanistic sense. Ref. [21] suggests that the parallel relationship only holds when the mass impedances are small. However, we suppose that R_{ct} is calculated by combining the necessary resistances from wherever in the circuit they occur, so this need not be a restriction. For a numerical example of the significance

of the Tafel plots, consider the hydrogen oxidation reaction (HOR) with the following mechanism:

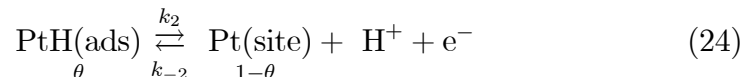
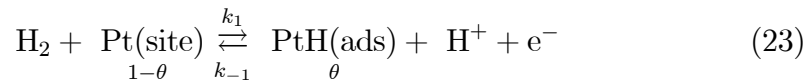

The adsorbed hydrogen has fractional coverage θ and H_2 and H^+ are considered as external species. Suppose that the second step is rate determining, so that the first step can be considered as a pre-equilibrium. Then the classical analysis (valid for low coverages) says that the expected transfer coefficient deduced from the measured Tafel slope of the steady-state current-potential relationship is $\alpha = 1 + \beta_2 \approx 1.5$. In contrast, we expect R_{ct} to be unrelated to the position of the rds in the mechanism, and that a Tafel plot of R_{ct} leads to $\alpha_R \approx \beta_1 \approx \beta_2 \approx 0.5$. This mechanism has the advantage that an analytical expression can be obtained for the steady state current and the charge transfer resistance (see, e.g., [17]) and so this expectation can be numerically tested. Fig. 5 shows Tafel plots for the steady-state current and charge-transfer resistances, for rate constants that lead to low coverages over the whole overpotential range. The higher slope of the R_{ct} plot by a factor of three reflects the three times lower apparent transfer coefficient ($\alpha_R = 0.5$ vs $\alpha = 1.5$). If the Tafel slope from the R_{ct} plot were naively interpreted as indicating where the rds lies in the mechanism, the incorrect conclusion would be that the first step were rate determining.

Although in general R_{ct} Tafel plots always lead to $\alpha_R = 0.5$ and have no diagnostic usefulness, there are two simple exceptions. The first is where there is a single semicircle, so that $R_{\text{ct}} = R_{\text{p}}$ and then the two plots lead to the same correct conclusion. The second is where R_{ct} indicates that $\alpha_R = 1$, indicating that there is a concerted two-electron reaction. This discussion suggests that a measurement of the potential dependence of R_{ct} may be the easiest way to detect concerted two-electron transfer steps.

2.2.3. Inductive behavior.

The significance of inductors has continued to be a topic of active interest, perhaps because they seem to imply a magnetic field, which is not present at the electrochemical interface. If a capacitor dominates the impedance, the

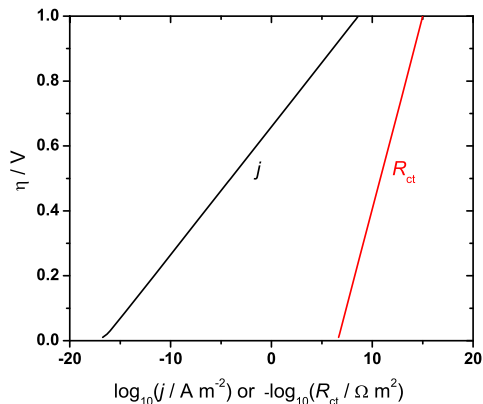

Figure 5: Tafel plots for HOR example. Mechanism of Eqs (23) and (24) for rate parameters, $k_1 = 1$, $k_{-1} = 1 \times 10^{18}$, $k_2 = 1 \times 10^{-4}$, $k_{-2} = 1 \times 10^{-22}$ (all $\text{mol m}^{-2} \text{s}^{-1}$), $\beta_1 = \beta_2 = 0.5$.

current lags the potential and the impedance is above the real axis (Fig. 4a), but if an inductor dominates the impedance, the current leads the potential and the impedance is below the real axis (Fig. 4b). The fact that kinetic equations predict that the impedance is sometimes below the axis requires that the corresponding equivalent (not real!) circuit will contain an inductor; there is no implication that magnetic fields are present. Monte-Carlo simulations of a two step adsorption/desorption mechanism (such as the HOR mechanism above) have been used to emphasize the point that kinetics alone are sufficient to give inductive behavior [25, 26]. Inductive behavior in corrosion has long been associated with inhibitors [27], but this cannot be a universal explanation. A nice review of the history of these ideas is given in [25].

Although the "meaning" of inductive behavior remains elusive, it is useful to categorize adsorption mechanisms with Langmuir kinetics that may or may not show this behavior. We apply the adjective "inductive" to a mechanism that has an equivalent circuit with positive element values and at least one inductor for some set of rate constants at some potential. At other potentials or sets of rate constants the circuit may have only resistors or capacitors, i.e., an inductive mechanism is one that *may* have an equivalent circuit with an

inductor. In fact, since all such mechanisms have RC circuits at equilibrium [6], there is no mechanism that is always inductive. We previously showed [28] that for mechanisms with a single adsorbed species, inductive behavior requires the combination of (i) a step that has the adsorbed species on the same side of the reaction as the electrons, i.e., is Oxidizing in the Direction of Adsorption (ODA), e.g., reaction (23), and (ii) a step that has the adsorbed species on the other side of the reaction from the electrons, i.e., is Reducing in the Direction of Adsorption (RDA), e.g., reaction (24). In a loose sense, oxidation and reduction processes are working in opposition on an adsorbed species. The above mechanism for the HOR, reactions (23) and (24), has both ODA and RDA steps and can show inductive behavior.

This is a mechanism with two relaxations (semicircles), and examination of the possibilities for this case (Fig. 4) shows that the inductive case corresponds to the case where $R_p < R_{ct}$. The case with a negative time constant (Fig. 4c) also has $R_p < R_{ct}$ but a negative time constant is unusual, and we may therefore anticipate inductive behavior when $R_p < R_{ct}$. That is, the inductive nature is perhaps less significant than the fact that the impedance decreases on going to lower frequencies. The criterion $R_p < R_{ct}$ in some sense means that the overall (low-frequency) rate is faster than the intrinsic rate of electron transfer. This seems paradoxical if there is only a single electron-transfer step. However, two electron-transfer steps working cooperatively to produce and then remove the intermediate (ODA+RDA) can facilitate the responsiveness of the overall rate to the potential.

One class of mechanisms that can never show inductive behavior and always have RC circuits are those with tree-graph structures and only one electron [29]. Mechanisms that only have RC circuits are rather rare because the circuit theory criterion for RC behaviour is rather restrictive: the poles and zeroes must alternate along the negative real axis of the s plane. Given that pole-zero locations can in general be sprinkled anywhere in the left half-plane, mechanisms that can show inductive behavior will be the rule rather than the exception.

The ODA+RDA mechanisms are inductive because the poles and zeroes no longer alternate, but they are still real. Inductive behavior also occurs when the poles or zeroes become complex; there must be at least two adsorbed species for this to happen. Note that zeroes relate to the "skeletal" structure of the mechanism in the absence of electrons. Classification of different mechanisms with two adsorbed species [30] as to the location of the zeroes showed that a mechanism with a single cycle skeleton (of any stoi-

chiometry) could have complex zeroes. Here we have verified that the simplest cycle (all reactions first order) can be "dressed" with external species and one electron to give a real mechanism, reactions (7) - (9), that does show inductive behavior. This illustrates that two electrons are not required for inductive behaviour; it also seems to lack the "electrons in opposition" behavior that was required for single-adsorbate mechanisms. Diard et al [31] examined a mechanism with two adsorbed species and saw inductive behavior; their mechanism was a two-electron mechanism containing ODA and RDA steps, but they did also find inductive behavior associated with complex poles or zeroes.

The two mechanisms, (7) - (9) and (17) - (19), have the same skeletal structure. Therefore, they share the same criterion, Eq. (15), for inductive behavior arising from the complex nature of the zeroes of the impedance. The skeletal structure of single adsorbed mechanisms is trivial (connections only between the adsorbed species and sites), but recognition of common origins for inductive behavior will be significant in better understanding inductance in more complicated mechanisms. Although we have discussed the common inductive behavior arising from the zeroes for the two "dressed" examples, we have not attempted to explore other types of inductive behaviour that might arise in these mechanisms.

3. Conclusions

We have argued that equivalent circuits are useful in analyzing impedance spectra arising from reaction mechanisms. They provide a measurement model to validate the data, and the number and type of circuit elements can be used to screen candidate mechanisms. There is rarely a direct physical significance of the values of the circuit element, since parameters from different physical processes are typically coupled in complicated ways. For reaction mechanisms with adsorbed species and fast mass transport, the ladder circuit (e.g., circuit 2a) has elements that are more simply related to kinetic parameters than other forms, except perhaps in the case of a single adsorbed species. Analysis of the potential dependence of element values can then be used to further narrow down possible reaction mechanisms. This procedure is more systematic than directly fitting data to a range of kinetic models.

Two mechanisms, each with two adsorbed species, illustrate the above ideas. These mechanisms have the same skeletal structure when external species and electrons are removed: that of a simple cycle in the adsorbed

species ($M \rightarrow MA \rightarrow MB \rightarrow M$). This common structure means that a common criterion for when these mechanisms must be inductive can be given. One of these mechanisms, reactions (17) - (19), proceeds at a finite rate, but the steady-state current is zero. This has a circuit that is blocking at dc, indicating that blocking behavior implies a lack of current but not necessarily a lack of reaction rate.

The significance of the polarization and charge transfer resistances has been discussed. Tafel plots of R_{ct} are not diagnostic of where the rate-determining step is in a reaction mechanism, but are sensitive to concerted two-electron transfer steps.

4. Acknowledgements

We thank the Natural Sciences and Engineering Research Council of Canada and the University of Victoria for financial support of this research. We thank Frode Seland and Dan Bizzotto for useful discussions relating to this work.

A.

The impedance for a general mechanism with adsorption but without mass transport is given by (25)

$$Z = -\frac{|-\Gamma_m^{-1}\mathbf{Q}(1) - s\mathbf{I}|}{C_{dl}|-\Gamma_m^{-1}\mathbf{Q} - s\mathbf{I}|} \quad (25)$$

where $\mathbf{Q} = -\mathbf{N}\mathbf{J}$ is a matrix constructed as described in [28, 29], $\mathbf{Q}(1)$ is the same matrix with its first ("electron") row and column removed, $s = i\omega$, Γ_m is the surface concentration of M atoms (mol m^{-2}) and \mathbf{I} is the appropriately-sized identity matrix. The parameters I , I' and X are defined as $I = \text{rank}(\mathbf{N})$, $I' = \text{rank}(\mathbf{N}(1))$ and $X = 2(\text{rank}(\mathbf{N}) - \text{rank}(\mathbf{N}(1))) = 2(I - I')$. For the mechanism of (7)-(9), with v_1 , v_2 , v_3 given by (10)-(12),

$$\begin{aligned} \mathbf{J} &= \begin{bmatrix} -(F\Gamma_m/C_{dl})(\partial v_1/\partial E) & \partial v_1/\partial\theta_{MA} & \partial v_1/\partial\theta_{MB} & \partial v_1/\partial\theta_M \\ -(F\Gamma_m/C_{dl})(\partial v_2/\partial E) & \partial v_2/\partial\theta_{MA} & \partial v_2/\partial\theta_{MB} & \partial v_2/\partial\theta_M \\ -(F\Gamma_m/C_{dl})(\partial v_3/\partial E) & \partial v_3/\partial\theta_{MA} & \partial v_3/\partial\theta_{MB} & \partial v_3/\partial\theta_M \end{bmatrix} \quad (26) \\ &= \begin{bmatrix} -k_e & -k_{-1} & 0 & k_1 \\ 0 & k_2 & -k_{-2} & 0 \\ 0 & 0 & k_3 & -k_{-3} \end{bmatrix} \quad (27) \end{aligned}$$

where $k_e = (F^2\Gamma_m/RTC_{dl})((1 - \beta_1)k_1 + \beta_1k_{-1})$ with β_1 the symmetry factor for step 1. Multiplying by $-\mathbf{N}$ gives:

$$\mathbf{Q} = \begin{bmatrix} k_e & k_{-1} & 0 & -k_1 \\ k_e & k_{-1} + k_2 & -k_{-2} & -k_1 \\ 0 & -k_2 & k_3 + k_{-2} & -k_{-3} \\ -k_e & -k_{-1} & -k_3 & k_1 + k_{-3} \end{bmatrix} \quad (28)$$

$$\mathbf{Q}(1) = \begin{bmatrix} k_{-1} + k_2 & -k_{-2} & -k_1 \\ -k_2 & k_3 + k_{-2} & -k_{-3} \\ -k_{-1} & -k_3 & k_1 + k_{-3} \end{bmatrix} \quad (29)$$

It may be explicitly verified that $\text{rank}(\mathbf{Q}) = \text{rank}(\mathbf{N}) = 3$ and $\text{rank}(\mathbf{Q}(1)) = \text{rank}(\mathbf{N}(1)) = 2$. Expansion of the determinants in (25) leads to (30), so that the coefficients in this equation are sums of products of rate constants (scaled according to Γ_m); the two numerator coefficients being given in (31) and (32) as examples.

$$Z = \frac{\Gamma_m (s^2 + a_1s + a_2) s}{C_{dl}(s^3 + b_1s^2 + b_2s + b_3)s} \quad (30)$$

$$a_1 = \frac{k_1 + k_{-1} + k_2 + k_{-2} + k_3 + k_{-3}}{\Gamma_m} \quad (31)$$

$$a_2 = \frac{k_2k_3 + k_{-3}k_{-1} + k_{-3}k_{-2} + k_{-3}k_2 + k_1k_3 + k_1k_{-2} + k_1k_2 + k_{-1}k_3 + k_{-1}k_{-2}}{\Gamma_m^2} \quad (32)$$

The common factors of s in the numerator and denominator of (30) can be cancelled to give (5). If the numerator has complex roots, the equivalent circuit is inductive [13]. These roots are eigenvalues of the matrix $-\Gamma_m^{-1}\mathbf{Q}(1)$, which are $-\Gamma_m^{-1}$ times the eigenvalues of $\mathbf{Q}(1)$, which are the eigenvalues of $\mathbf{RQ}(1)\mathbf{R}^{-1}$ where \mathbf{R} is defined implicitly below.

$$\begin{aligned} \mathbf{RQ}(1)\mathbf{R}^{-1} &= \begin{bmatrix} 1 & 0 & 0 \\ 0 & 1 & 0 \\ 1 & 1 & 1 \end{bmatrix} \begin{bmatrix} k_{-1} + k_2 & -k_{-2} & -k_1 \\ -k_2 & k_3 + k_{-2} & -k_{-3} \\ -k_{-1} & -k_3 & k_1 + k_{-3} \end{bmatrix} \begin{bmatrix} 1 & 0 & 0 \\ 0 & 1 & 0 \\ -1 & -1 & 1 \end{bmatrix} \\ &= \begin{bmatrix} k_1 + k_{-1} + k_2 & k_1 - k_{-2} & -k_1 \\ k_{-3} - k_2 & k_{-3} + k_3 + k_{-2} & -k_{-3} \\ 0 & 0 & 0 \end{bmatrix} \end{aligned} \quad (34)$$

The zero eigenvalue gives the factor s in the numerator of 30; the other two eigenvalues of $\mathbf{Q}(1)$ are the eigenvalues of

$$\tilde{\mathbf{Q}} = \begin{bmatrix} k_1 + k_{-1} + k_2 & k_1 - k_{-2} \\ k_{-3} - k_2 & k_{-3} + k_3 + k_{-2} \end{bmatrix} \quad (35)$$

This has the characteristic polynomial $P(s)$

$$P(s) = s^2 - \text{trace}(\tilde{\mathbf{Q}})s + \det(\tilde{\mathbf{Q}}) \quad (36)$$

which has complex roots if and only if the discriminant is negative

$$\text{discrim}(P) = \text{trace}^2(\tilde{\mathbf{Q}}) - 4 \det(\tilde{\mathbf{Q}}) \quad (37)$$

$$= (a - b)^2 + (b - c)^2 + (c - a)^2 - (a^2 + b^2 + c^2) \quad (38)$$

$$= u^2 + v^2 - w^2 \quad (39)$$

where $a = k_1 - k_{-2}$, $b = k_2 - k_{-3}$, $c = k_3 - k_{-1}$ and $u = (a + b - 2c)/\sqrt{3}$, $v = b - a$, $w = (a + b + c)/\sqrt{3}$. That is, inductive behavior occurs for

$$(a^2 + b^2 + c^2) > (a - b)^2 + (b - c)^2 + (c - a)^2 \quad (40)$$

the inequality stated in (15), or equivalently

$$w^2 > u^2 + v^2 \quad (41)$$

Equality in (41) defines a pair of cones in (u, v, w) space within which the behavior is inductive. For equality in (40), the shapes in (a, b, c) space are similar but distorted. The circuit elements for the RC and inductive cases (circuits 2c,e and 3a,b) are given by

$$R_{\text{ct}} = \frac{\Gamma_m}{C_{\text{dl}}k_e} = \frac{RT}{F^2 [(1 - \beta_1)k_1 + \beta_1k_{-1}]} \quad (42)$$

$$C_1 = \frac{C_{\text{dl}}k_e}{k_1 + k_{-1}} \quad (43)$$

$$R_1 = \frac{\Gamma_m(k_{-1} + k_1)^2}{(k_{-3}k_1 + k_{-1}k_2)C_{\text{dl}}k_e} \quad (44)$$

$$R_6 = \frac{(k_1k_2 + k_{-2}k_1 + k_{-2}k_{-1} + k_3k_1 + k_3k_{-1} + k_{-3}k_{-1})\Gamma_m}{(k_{-2}k_{-3} + k_{-3}k_2 + k_3k_2)k_eC_{\text{dl}}} \quad (45)$$

$$L/R_7 = R_2C_2 = \frac{(k_1k_{-3} + k_2k_{-1})\Gamma_m}{k_{-2}k_{-3}k_1 + k_{-1}k_{-2}k_{-3} + k_2k_3k_1 + k_3k_2k_{-1} + k_{-3}k_2k_1 + k_{-3}k_2k_{-1}} \quad (46)$$

where we have omitted the overly complicated expressions for R_2 , C_2 , R_7 and L .

B.

(Adapted from Ref. [32] with permission.) We here show that $\lim_{\omega \rightarrow 0} Z(\omega) = (dj_{ss}/dE)^{-1}$

Assume potentiostatic regulation. The admittance is the transfer function for potentiostatic control, being the Laplace transform of the output (current) over the Laplace transform of the input (potential). It would seem straightforward to apply a constant potential E at time $t = 0$ with Laplace transform E/s (where s is the Laplace parameter) and calculate the output current as the inverse Laplace transform of $Y(s)E/s$, and this would be correct if the system were linear. However, we deal in electrochemistry with non-linear systems that are linearized around the operating point. Therefore we suppose that the system is initially at steady state with applied potential E and resulting steady-state current density j_{ss} . We then make a small step in potential δE away from steady-state and wait for a new steady state. The Laplace transform of a small potential step at time $t = 0$ is $\delta E/s$. Therefore the Laplace transform of the current output perturbation of the linearized system is the transfer function $Y(s)$ times $\delta E/s$. The value of the current perturbation after a long time, δj , can be found from the final value theorem: $f(t \rightarrow \infty) = \lim_{s \rightarrow 0} sF(s)$ [33]. The result is that $\delta j = \lim_{s \rightarrow 0} sY(s)\delta E/s = \lim_{s \rightarrow 0} Y(s)\delta E = \delta E \lim_{s \rightarrow 0} Y(s)$. Thus the slope of the polarization curve $\delta j/\delta E$ is equal to $\lim_{s \rightarrow 0} Y(s)$, which is the polarization resistance determined by extrapolating the impedance spectrum to zero frequency.

The proof uses the final value theorem, which requires stability, i.e., the absence of poles in the closed right half plane. Thus, whenever we have stability, the relationship holds: it is a sufficient condition. Since stability is a prerequisite for achieving a steady current at an imposed dc potential, it is usually also a prerequisite for making an impedance measurement that perturbs around this steady state. However, tests show that this relationship appears to hold more widely than this, for example on the unstable branches of the current potential curve exhibited in case of the Frumkin isotherm [34].

References

- [1] D. Schuhmann, *Electrochim. Acta* 35 (1990) 1527.
- [2] A. Lasia in: *Modern Aspects of Electrochemistry*, B. E. Conway, J.

Bockris, and R. White, Eds., Kluwer Academic/Plenum, New York, 1999, Vol. 32, pp. 143-248.

- [3] D.A. Harrington, *J. Electroanal. Chem.*, 403 (1996) 11.
- [4] D.A. Harrington, *J. Electroanal. Chem.*, 449 (1998) 9.
- [5] D.A. Harrington, *J. Electroanal. Chem.*, 449 (1998) 29.
- [6] D.A. Harrington, P. van den Driessche, *Electrochim. Acta*, 44 (1999) 4321.
- [7] J.P. Diard, B. Le Gorrec, C. Montella, *J. Electroanal. Chem.* 205 (1986) 77.
- [8] L. Pauwels, A. Hubin, B. Van Den Bossche, L. Bortels, J. Deconinck, *Electrochim. Acta*, 51 (2006) 1505.
- [9] C. Dan, B. Van Den Bossche, L. Bortels, G. Nelissen, J. Deconinck, *J. Electroanal. Chem.* 505 (2001) 12.
- [10] A.C.D. Angelo, A. Lasia, *J. Electrochem. Soc.* 142 (1995) 3313.
- [11] J. Vazquez-Arenas, M. Pritzker *J. Electrochem. Soc.* 157 (2010) D283.
- [12] S. Fletcher, *J. Electrochem. Soc.*, 141 (1994) 1823-1826.
- [13] G.C. Temes and J.W. LaPatra, *Circuit Synthesis and Design*, McGraw-Hill, N.Y., 1977.
- [14] P. Zoltowski, *J. Electroanal. Chem.*, 375 (1994) 45.
- [15] P. Zoltowski, *J. Electroanal. Chem.*, 424 (1997) 173.
- [16] C. Gabrielli, M. Keddam, *Electrochim. Acta*, 41 (1996) 957.
- [17] D.A. Harrington, B.E. Conway, *Electrochim. Acta*, 32 (1987) 1703.
- [18] D. Schuhmann, *J. Electroanal. Chem.* 17 (1968) 45.
- [19] M. Naito, N. Tanaka, H. Okamoto, *J. Chem. Phys.* 111 (1999) 9908.
- [20] C. Gabrielli, B. Tribollet, *J. Electrochem. Soc.* 141 (1994) 1147.

- [21] M. Sluyters-Rehbach, *Pure Appl. Chem.* 68 (1994) 1831.
- [22] F. Berthier, J.-P. Diard, C. Montella, *Electrochim. Acta* 44 (1999) 2397.
- [23] A.N. Frumkin, V. I. Melik-Gaikazyan, *Dokl. Akad. Nauk*, 77 (1951) 855.
- [24] J. O'M. Bockris and A.K.N Reddy, *Modern Electrochemistry*, v 2, Ch 9, Plenum, N.Y., 1970.
- [25] P. Córdoba-Torresa, M. Keddám, R.P. Nogueira, *Electrochim. Acta*, 54 (2008) 518.
- [26] P. Córdoba-Torresa, M. Keddám, R.P. Nogueira, *Electrochim. Acta*, 54 (2009) 6779.
- [27] I. Epelboin, M. Keddám, H. Takenouti, *J. Appl. Electrochem.* 2 (1972) 71.
- [28] D.A. Harrington, P. van den Driessche, *J. Electroanal. Chem.*, 501 (2001) 222.
- [29] D.A. Harrington, P. van den Driessche, *J. Electroanal. Chem.* 567 (2004) 153.
- [30] J.D. Campbell, D.A. Harrington, P. van den Driessche, J. Watmough, *J. Math. Chem.* 32 (2002) 281.
- [31] J.-P. Diard, B. Le Gorrec, C. Montella, C. Montero-Ocampo, *J. Electroanal. Chem.*, 352 (1993) 1.
- [32] F. Seland, *Electrochemical Oxidation of Methanol and Formic Acid in Fuel Cell Processes*, Ph.D. thesis, Norwegian University of Science and Technology, Trondheim, 2005.
- [33] F.F. Kuo, *Network Analysis and Synthesis*, 2nd Ed., Wiley, NY, 1966, p. 167.
- [34] F. Berthier, J.-P. Diard, C. Montella, I. Volovik, *J. Electroanal. Chem.* 402 (1996) 29.