

Domination of a Generalized Cartesian Product

by

STEPHEN BENECKE

B.Sc., University of Stellenbosch, 2000

B.Sc. (Hons), University of Stellenbosch, 2001

M.Sc., University of Stellenbosch, 2004

A Dissertation Submitted in Partial Fulfillment of the
Requirements for the Degree of

DOCTOR OF PHILOSOPHY

in the Department of Mathematics and Statistics

© Stephen Benecke, 2009

University of Victoria

All rights reserved. This thesis may not be reproduced in whole or in part, by photocopying or other means, without the permission of the author.

Domination of a Generalized Cartesian Product

by

Stephen Benecke

B.Sc., University of Stellenbosch, 2000
B.Sc. (Hons), University of Stellenbosch, 2001
M.Sc., University of Stellenbosch, 2004

Supervisory Committee

Dr. C.M. Mynhardt (Department of Mathematics and Statistics)

Supervisor

Dr. G. MacGillivray (Department of Mathematics and Statistics)

Departmental Member

Dr. U. Stege (Department of Computer Science)

Outside Member

Supervisory Committee

Dr. C.M. Mynhardt

Supervisor

Dr. G. MacGillivray

Departmental Member

Dr. U. Stege

Outside Member

Abstract

Let $G \square H$ denote the Cartesian product of the graphs G and H . Domination of the Cartesian product of two graphs has received much attention, with a main objective to confirm the truth of Vizing's well-known conjecture. The conjecture states that the domination number of the Cartesian product of two graphs is at least as large as the product of the respective domination numbers. The potential truth of Vizing's conjecture gives rise to investigating the domination of graph products that generalizes the Cartesian product. The generalized prism πG of G is the graph consisting of two copies of G , with edges between the copies determined by a permutation π acting on the vertices of G . A generalized Cartesian product $G \boxtimes H$ is defined here, incorporating structural properties of both the Cartesian product of two graphs as well as the generalized prism of a graph.

Conditions on the isomorphism of two generalized Cartesian products are explored first, establishing a characterization in the case of natural isomorphisms. A comparison of the diameter of the generalized Cartesian product and the corresponding Cartesian product graph is used to illustrate the structural differences between these graph products. This comparison is continued through a study of the validity of an inequality similar to Vizing's conjecture for Cartesian products.

Graphs that attain equality in the general bounds for the domination number of the Cartesian product and generalized Cartesian product are investigated in more detail. For any graph G and $n \geq 2$, $\min\{|V(G)|, \gamma(G) + n - 2\} \leq \gamma(G \square K_n) \leq n\gamma(G)$. A graph G is called a consistent Cartesian fixer if $\gamma(G \square K_n) = \gamma(G) + n - 2$ for each n such that $2 \leq n < |V(G)| - \gamma(G) + 2$. A graph attaining equality in the stated upper bound on $\gamma(G \square K_n)$ is called a Cartesian n -multiplier. Both of these classes are characterized. Concerning the generalized Cartesian product, $\gamma(G \boxtimes K_n) \leq n\gamma(G)$ for any graph G , permutation π and $n \geq 2$. A graph attaining equality in the upper bound for all π is called a universal multiplier. Such graphs are characterized similar to a known result for generalized prisms. A similar problem for the product $G \boxtimes C_n$ is considered, with conditions on a graph being a so-called cycle multiplier provided. A graph attaining equality in the lower bound $\gamma(G \boxtimes H) \geq \gamma(G)$ for some permutation π is called a π - H -fixer. A brief investigation is conducted into the existence of universal H -fixers, i.e. graphs that are π - H -fixers for some H and all permutations π of $V(G)$, and it is shown that no such graphs exist when $n \geq 3$. A known efficient algorithm for determining $\gamma(G \square P_n)$ is surveyed, and modified to accommodate any Cartesian product $G \square H$, thereby establishing a general framework for evaluating the domination number of $G \square H$ for a fixed graph G and any H . An algorithm to determine $\gamma(G \square T)$ for any tree T is provided, and it is observed to be polynomial for trees of bounded maximum degree. The general framework for $G \square H$ is also modified to accommodate the generalized Cartesian product $G \boxtimes H$.

The study diverts from the main topic of domination to investigate the planarity of the generalized Cartesian product graph. If both G and H are 2-connected graphs, then $G \boxtimes H$ is nonplanar. A known simple polynomial-time planarity testing algorithm is surveyed, and used to establish conditions on the planarity of $P_m \boxtimes P_n$, the generalized Cartesian product of two paths.

This research aims to lay the foundation on which further properties of the generalized

Cartesian product and further generalizations may be studied, as well as to provide various open problems to spark interest in the research area.

Table of Contents

Supervisory Committee	ii
Abstract	iii
Table of Contents	vi
List of Tables	viii
List of Figures	ix
Acknowledgements	xii
1 Introduction	1
1.1 A Generalized Cartesian Product	2
1.2 Survey of Recent Results	7
1.2.1 Vizing’s Conjecture	7
1.2.2 Domination of Cartesian Products	12
1.2.3 Other Graph Products	14
1.3 Thesis Overview	19
2 A Preliminary Investigation	23
2.1 Introduction	23
2.2 Natural Isomorphisms	24
2.3 The Diameter	36
2.4 A Vizing Inequality	43
2.5 Chapter Summary	55

3	Fixers and Multipliers	56
3.1	Introduction	56
3.2	Cartesian Fixers	57
3.2.1	Consistent Fixers	58
3.2.2	Other Fixers	68
3.3	Cartesian Multipliers	80
3.4	Universal Multipliers	83
3.5	Universal Cycle-multipliers	97
3.6	Universal Fixers	108
3.7	Chapter Summary	113
4	Domination Algorithm for Generalized Cartesian Products	114
4.1	Introduction	114
4.2	The Cartesian Product $G \square P_n$	115
4.3	A General Framework for $\gamma(G \square H)$	120
4.4	An Algorithm for $\gamma(G \square T)$	124
4.5	The Generalized Cartesian Product $G \boxtimes H$	131
4.6	Chapter Summary	135
5	Planarity	136
5.1	Introduction	136
5.2	A Planarity Testing Algorithm	139
5.3	Planarity Conditions	144
5.4	Chapter Summary	161
6	Conclusion	163
6.1	Thesis Summary	163
6.2	Further Work	165
6.3	A Further Generalization	169
	References	171

List of Tables

2.1	An isomorphism $\phi : \alpha C_8 \mapsto \pi C_8$	25
2.2	The automorphism group of C_5 and the sets $S_j(\mathbf{1})$, $j = 1, 2$	33
4.1	All possible states of K_2	116
4.2	The cost matrix used to determine $\gamma(G \square P_7)$	120
4.3	All possible states of P_3	129
4.4	The entries of the matrices W and P used to determine $\gamma(P_3 \square T)$	130
4.5	Minimum and maximum domination numbers $\gamma(C_5 \boxtimes C_n)$ for sample values of n	134
5.1	The states describing a planar embedding of $P_m \boxtimes P_n$	152

List of Figures

1.1	$P_3 \square C_3$ and $P_3 \boxtimes C_3$, with $\pi = (v_1, v_2)$	4
1.2	The generalized Cartesian product $C_4 \boxtimes P_4$, $\pi = (v_1, v_2, v_3)$	6
1.3	$P_3 \boxtimes P_3$ and $\overline{P_3} \boxtimes \overline{P_3}$, with $\pi = (v_1, v_2)$	7
1.4	A graph bundle $C_3 \times^\phi C_4$ that is not a generalized Cartesian product $C_4 \boxtimes C_3$ for any π	19
1.5	A diagram showing the relationships between the various graph products.	20
2.1	Isomorphic generalized prisms αC_5 and πC_5	25
2.2	Isomorphic generalized prisms αC_8 and πC_8	26
2.3	Nonisomorphic generalized Cartesian products $C_5 \boxtimes P_3$ and $C_5 \boxtimes P_3$	26
2.4	A natural isomorphism between two generalized Cartesian products $G \boxtimes H$ and $G \boxtimes H$	29
2.5	The nonisomorphic generalized Cartesian products $G \boxtimes H$ and $G \boxtimes H'$, where $\pi = (v_1, v_2)$	31
2.6	The graph $G \boxtimes H$, with $G = 3K_2$, $H = P_3$ and $\pi = (v_1, v_2, v_3)(v_4, v_5, v_6)$	33
2.7	The graph $P_3 \boxtimes P_3$, $\pi = (v_1, v_2)$	38
2.8	The tree T	38
2.9	The generalized Cartesian product $P_3 \boxtimes C_5$, with $\pi = (v_1, v_2)$	40
2.10	The generalized Cartesian product $P_3 \boxtimes C_5$, $\pi = (v_1, v_2)$	41
2.11	The generalized Cartesian product $P_4 \boxtimes C_5$, $\pi = (v_1, v_3)$	42
2.12	The graph G_3	42
2.13	A domination strategy of $\text{cor}(K_m) \boxtimes C_4$	46
2.14	A domination strategy of the set Y in the case $m \equiv 2 \pmod{3}$	46
2.15	A domination strategy of $\text{cor}(K_m) \boxtimes C_n$	48
2.16	A domination strategy of $\text{cor}(G) \boxtimes C_n$	50

3.1	The graph G_3	58
3.2	A domination strategy for $G \square K_n$ if G has a primitive symmetric γ -set. . .	59
3.3	A consistent fixer with no primitive symmetric γ -set.	67
3.4	A graph that is a 2-fixer and a 4-fixer, but not a 3-fixer.	69
3.5	An n -fixer only for $n \geq 4$	76
3.6	$C_6 \boxtimes K_3$, with $\pi = (v_4, v_6)$	84
3.7	Universal 2-multipliers $H_{2,4}$ and $H_{3,4}$	85
3.8	Dominating the layer G_2 in $G \boxtimes C_n$	99
3.9	The circulant $C_{10}\langle 1, 2 \rangle$	100
3.10	A domination strategy for $C_{10}\langle 1, 2 \rangle \square C_n$	101
3.11	A domination strategy of a layer G_j in $H_{l,2k} \boxtimes C_n$, $j \neq 1, n$	102
3.12	A domination strategy of $H_{l,2k} \boxtimes C_n$	103
3.13	The graph $F_{2,k}$	105
3.14	The graph $F_{l,k}$, $l \geq 3$	106
3.15	The graph $G \in \mathcal{G}_3$	110
4.1	The labelling l_D for $K_2 \square P_7$ corresponding to $D = \{v_{1,1}, v_{2,1}, v_{1,3}, v_{1,5}, v_{2,5}, v_{2,7}\}$	116
4.2	The state-transition graph of K_2	117
4.3	The labelling for $K_2 \square P_7$ corresponding to a γ -set $D = \{v_{2,1}, v_{1,3}, v_{2,5}, v_{1,7}\}$	118
4.4	The state-transition graph \mathcal{G} of K_2	122
4.5	The tree T rooted at vertex v_0	131
4.6	A minimum weight conditional homomorphism $\phi : T_v \mapsto \mathcal{G}$	131
4.7	A minimum dominating set of $P_3 \square T$	132
4.8	A minimum weight mapping $\phi : V(T_v) \mapsto V(\mathcal{G})$	133
4.9	A minimum dominating set of $P_3 \boxtimes T$, $\pi = (w_1, w_2)$	134
5.1	B_1 and B_2 are bridges of $H = \langle \{v_1, v_2, \dots, v_5\} \rangle$	137
5.2	The graph $G = K_5 - \{v_2v_4\}$ with two embeddings, \hat{H}_1 and \hat{H}_2 , of $H = G - \{v_4v_5\}$	138
5.3	A graph G with planar embedding \hat{G}	142
5.4	Partial embeddings of G produced by Algorithm 5.2.1.	143
5.5	An embedding of two copies G_1 and G_2 of the outerplanar graph G in πG	144

5.6	A partial embedding when $\text{med}(\pi(i), \pi(j), \pi(i-1))$	146
5.7	The planar embedding of \hat{H}_2	149
5.8	The two possible cases for \hat{H}_j	149
5.9	The embedding in case (a) when $v_{\pi(i),j} \in V_{j+1}^{(c)}$ for some $v_{i,j} \in V_j^{(c)}$	150
5.10	The embedding in case (a) when $v_{\pi(i),j} \notin V_{j+1}^{(c)}$ for any $v_{i,j} \in V_j^{(c)}$	151
5.11	The state-transition graph D	153
5.12	Planar matchings of types 1a and 6a.	153
5.13	Planar matchings of types 1b and 6b.	154
5.14	Planar matchings of types 2 and 5.	155
5.15	Planar matchings of types 3 and 4.	156
5.16	A partitioning of the vertices of πP_m	157
5.17	A partitioning of the vertices of πP_m , where $s_2^{(c)}$ is empty.	157
5.18	Planar matchings of types 7a and 7b.	158
5.19	A planar matching of type 7c.	159
5.20	A planar matching of type 7d.	160
5.21	$P_5 \boxtimes P_5$, with $\pi = (v_1, v_2)(v_3, v_5)$	161
5.22	Planar matchings of $\pi = (v_1, v_2)(v_3, v_5)$	162
5.23	A planar embedding of $P_5 \boxtimes P_5$, with $\pi = (v_1, v_2)(v_3, v_5)$	162
6.1	The product $G \boxtimes H$	170

Acknowledgements

The author hereby wishes to express his gratitude toward

- the Department of Mathematics and Statistics of the University of Victoria for the use of their computing facilities, office space and other forms of assistance,
- Dr. C.M. Mynhardt, for her unwavering support, guidance and patience,
- Dr. G. MacGillivray, for his leadership and support, both as chair of the Department and within the discrete mathematics research group,
- his fellow graduate students, for their enthusiasm to discuss any and all mathematics related topics.

The financial assistance of the National Research Foundation (NRF) of South Africa toward this research, as well as the Skye Foundation, is hereby acknowledged. Opinions expressed and conclusions arrived at, are those of the author and are not necessarily to be attributed to these organizations.

Chapter 1

Introduction

Domination of the Cartesian product of two graphs has received much attention over the past 25 years, with a main objective to confirm the truth of Vizing's well-known conjecture. The conjecture states that the domination number of the Cartesian product of two graphs is at least as large as the product of the respective domination numbers. Although it remains an open problem in general, the conjectured bound has been confirmed for many large classes of graphs. Vizing's conjecture has inspired many researchers to investigate the possibility of similar bounds for other domination parameters as well as other graph products. The potential truth of the conjecture gives rise to investigating similar inequalities for graph products that generalize the Cartesian product.

Various such graph products may be viewed as generalizations of the Cartesian product. However, none maintains what is deemed a key property of the Cartesian product. The first step towards investigating a generalized Cartesian product that incorporates structural properties of both the Cartesian product of two graphs as well as the generalized prism of a graph is taken here. With the primary focus on the domination of this *generalized Cartesian product*, various relationships between the domination number of the product and that of the respective graphs are explored. The objective of this research is to lay the

foundation on which further properties of the generalized Cartesian product and further generalizations may be studied, as well as to provide various open problems to spark interest in the research area.

Section 1.1 defines the generalized Cartesian product graph, relating it to both the Cartesian product and the generalized prism graph. A survey of the literature on the domination of Cartesian products is conducted in Section 1.2, highlighting progress towards proving Vizing's conjecture. Other graph products that may be considered as possible generalizations of the Cartesian product are discussed, placing the new generalized Cartesian product definition into context.

1.1 A Generalized Cartesian Product

Unless stated otherwise, the notation and terminology of [42] is followed. For two graphs G and H , the *Cartesian product* $G \square H$ is the graph with vertex set $V(G) \times V(H)$, where vertex (v_i, u_j) is adjacent to (v_k, u_l) if and only if (i) $v_i v_k \in E(G)$ and $u_j = u_l$, or (ii) $v_i = v_k$ and $u_j u_l \in E(H)$. This definition is stated below for referencing purposes.

Definition 1.1.1 *The Cartesian product of two graphs G and H is the graph $G \square H$ with vertex set $V(G \square H) = V(G) \times V(H)$, and $(v_i, u_j)(v_k, u_l) \in E(G \square H)$ if and only if*

- (i) $v_i v_k \in E(G)$ and $u_j = u_l$, or
- (ii) $v_i = v_k$ and $u_j u_l \in E(H)$.

The graph $G \square K_2$ is called the *prism* of G . As usual, $\gamma(G)$ denotes the domination number of G . The set $D \subseteq V(G)$ is called a γ -set if it is a dominating set with $|D| = \gamma(G)$. In 1967, Chartrand and Harary [9] defined the *generalized prism* πG of G as the graph consisting of two copies of G , with edges between the copies determined by a permutation π acting on

the vertices of G . The domination number $\gamma(\pi G)$ of the generalized prism of G is bounded between $\gamma(G)$ and $2\gamma(G)$ for any permutation π . The edgeless graph $G = \overline{K_m}$ attains equality in the lower bound for any permutation π , while $\gamma(\pi G) = 2\gamma(G)$ for the complete graph $G = K_m$ and any π , $m \geq 2$. The generalized prism πG of G can be defined as stated below.

Definition 1.1.2 For a graph G and permutation π of $V(G)$, the generalized prism of G is the graph πG with vertex set $V(\pi G) = V(G) \times V(K_2)$, and $(v_i, u_j)(v_k, u_l) \in E(\pi G)$ if and only if

- (i) $v_i v_k \in E(G)$ and $u_j = u_l$, or
- (ii) $v_k = \pi(v_i)$ and $u_j u_l \in E(K_2)$, $j \leq l$.

Definition 1.1.2 gives rise to the following definition of a *generalized Cartesian product*. Let $V(G) = \{v_1, v_2, \dots, v_m\}$ and $V(H) = \{u_1, u_2, \dots, u_n\}$. For two labelled graphs G and H and a permutation π of $V(G)$, the product $G \boxtimes H$ is the graph with vertex set $V(G) \times V(H)$, where vertex (v_i, u_j) is adjacent to (v_k, u_l) if and only if (i) $v_i v_k \in E(G)$ and $u_j = u_l$, or (ii) $v_k = \pi^{l-j}(v_i)$ and $u_j u_l \in E(H)$. This definition corresponds to the Cartesian product $G \square H$ when π is the identity, and to the generalized prism when H is the graph K_2 .

Definition 1.1.3 For two labelled graphs G and H and permutation π of $V(G)$, the product $G \boxtimes H$ is the graph with vertex set $V(G \boxtimes H) = V(G) \times V(H)$, where $(v_i, u_j)(v_k, u_l) \in E(G \boxtimes H)$ if and only if

- (i) $v_i v_k \in E(G)$ and $u_j = u_l$, or
- (ii) $v_k = \pi^{l-j}(v_i)$ and $u_j u_l \in E(H)$.

If a graph G is a path or a cycle with $V(G) = \{v_1, v_2, \dots, v_n\}$, it is assumed throughout this document that this labelling is a *canonical labelling* of G , that is, v_1, v_2, \dots, v_n is the vertex sequence along the path or cycle, unless stated otherwise. For the case $G \cong P_3$ and $H \cong C_3$, where G and H are canonically labelled v_1, v_2, v_3 and u_1, u_2, u_3 respectively, Figure 1.1 shows the Cartesian product of G and H , as well as the graph $G \boxtimes H$ for $\pi = (v_1, v_2)$. The generalized Cartesian product $G \boxtimes H$ is isomorphic to the Cartesian product $G \square H$ when $\pi \in \text{Aut}(G)$.

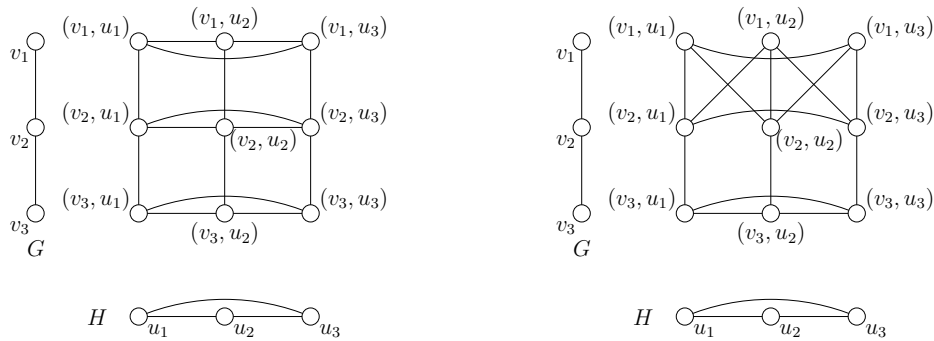


Figure 1.1: $P_3 \square C_3$ and $P_3 \boxtimes C_3$, with $\pi = (v_1, v_2)$.

Let G and H be graphs of order m and n respectively. The generalized Cartesian product $G \boxtimes H$ retains a so-called *layer-partition* property of the Cartesian product $G \square H$, in that its vertex set allows two partitions $\mathcal{P} = \{P_1, P_2, \dots, P_n\}$ and $\mathcal{Q} = \{Q_1, Q_2, \dots, Q_m\}$ such that

- each $P_i \in \mathcal{P}$ induces a subgraph isomorphic to G , called a *G-layer*,
- each $Q_j \in \mathcal{Q}$ induces a subgraph isomorphic to H , called an *H-layer*,
- any P_i and Q_j intersect in exactly one vertex, and
- any edge in the product is in either exactly one *G-layer* or exactly one *H-layer*.

Various graph structures have been defined that may be considered to be generalizations of the Cartesian product or the generalized prism graph, but which lack this layer-partition

property. These are discussed in Section 1.2.3.

The following terminology is used frequently throughout this document. For $A, B \subseteq V(G)$, “ A dominates B ” is abbreviated to “ $A \succ B$ ”. If $B = V(G)$, then it is expressed as $A \succ G$, while $A \succ b$ in the case of $B = \{b\}$. Further, $N_G(v) = \{u \in V(G) : uv \in E(G)\}$ and $N_G[v] = N(v) \cup \{v\}$ denote the *open* and *closed neighbourhoods*, respectively, of a vertex v of G . The subscript is omitted if the graph is clear from the context. The *closed neighbourhood* of $S \subseteq V(G)$ is the set $N[S] = \bigcup_{s \in S} N[s]$, the *open neighbourhood* of S is $N(S) = \bigcup_{s \in S} N(s)$, while $N\{S\}$ denotes the set $N(S) - S$. If $s \in S$, then the *private neighbourhood* of s relative to S , denoted by $\text{pn}(s, S)$, is the set $N[s] - N[S - \{s\}]$, while the *external private neighbourhood* of s relative to S , denoted by $\text{epn}(s, S)$, is the set $\text{pn}(s, S) - S$.

Consider two graphs G and H , with vertex sets labelled v_1, v_2, \dots, v_m and u_1, u_2, \dots, u_n respectively. Vertices (v_i, u_j) of $G \boxtimes H$ are often labelled $v_{i,j}$ for convenience. A vertex $v_{i,j}$ has as first coordinate the vertex $p_G(v_{i,j}) = v_i \in V(G)$ and second coordinate $p_H(v_{i,j}) = u_j \in V(H)$. For a set $A \subseteq V(G \square H)$, $p_G(A) = \bigcup_{v \in A} p_G(v)$ and $p_H(A) = \bigcup_{v \in A} p_H(v)$. Note that for the Cartesian product $G \square H$, the G -layer [H -layer] through a given vertex $v_{i,j}$ is the subgraph induced by all vertices that differ from $v_{i,j}$ only in the first [second] coordinate. The *Cartesian preimage* $p_G^{-1}(v_i)$ of a vertex v_i in G is the set of vertices in $G \square H$ that has v_i as first coordinate, and corresponds to the i^{th} H -layer of $G \square H$. The *Cartesian preimage* $p_H^{-1}(u_j)$ of a vertex u_j in H is defined similarly.

In the generalized Cartesian product $G \boxtimes H$, the i^{th} H -layer is the subgraph (isomorphic to H) induced by the set $\{(\pi^{j-1}(v_i), u_j) : j = 1, 2, \dots, n\}$. The preimage $p_{G,\pi}^{-1}(v_i)$ of a vertex $v_i \in V(G)$ is the vertex set of the H -layer containing vertex $v_{i,1} = (v_i, u_1)$. For a set of vertices $A \subseteq V(G)$, the *preimage* of A is the set $p_{G,\pi}^{-1}(A) = \bigcup_{v \in A} p_{G,\pi}^{-1}(v)$. As an example, consider the graph $C_4 \boxtimes P_4$ in Figure 1.2, where $\pi = (v_1, v_2, v_3)$. For this graph, $p_{C_4}(\{v_{1,3}, v_{3,2}\}) = \{v_1, v_3\}$ and the preimage $p_{C_4,\pi}^{-1}(v_1) = \{v_{1,1}, v_{2,2}, v_{3,3}, v_{1,4}\}$. When

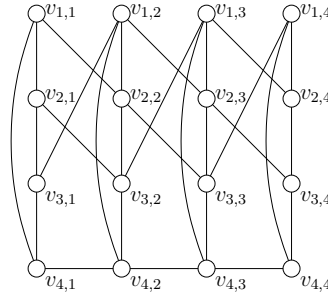
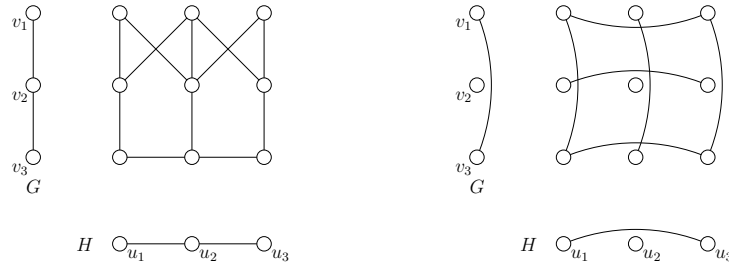


Figure 1.2: The generalized Cartesian product $C_4 \square P_4$, $\pi = (v_1, v_2, v_3)$.

considering $G \square K_n$ the subscript G is usually omitted, with $p_{G,\pi}^{-1}(v_i)$ and $p_{G,\pi}^{-1}(A)$ written as $p_\pi^{-1}(v_i)$ and $p_\pi^{-1}(A)$ respectively, or $p^{-1}(v_i)$ and $p^{-1}(A)$ for the Cartesian preimage (when π is the identity permutation).

A dominating set D of $G \square H$ can be partitioned into sets D_1, D_2, \dots, D_n , where D_i is a set of vertices in the i^{th} G -layer. Then D is written as $D = D_1 \cup D_2 \cup \dots \cup D_n$ where the partition is clear from the context. Lastly, for a permutation π of $V(G)$ and $X \subseteq V(G)$, $\pi(X) = X$ represents the case $\pi(x) \in X$ for each $x \in X$.

For any graphs G and H of order m and n respectively, and any permutation π of $V(G)$, the (disjoint) union of the generalized Cartesian products $G \square H$ and $\overline{G} \square \overline{H}$ yields the graph $K_m \square K_n$: Note that both $G \square H$ and $\overline{G} \square \overline{H}$ are spanning subgraphs of $K_m \square K_n$. Suppose $v_{i,j}v_{k,l} \in E(G \square H)$. If $u_j = u_l$, then $v_i v_k \in E(G)$, so that $v_i v_k \notin E(\overline{G})$. Otherwise $u_j u_l \in E(H)$ and $v_k = \pi^{l-j}(v_i)$. In other words $v_{i,j}v_{k,l}$ is an edge in some H -layer of $G \square H$, and it follows that it is not an edge in the corresponding \overline{H} -layer of $\overline{G} \square \overline{H}$. By a similar argument, an edge $v_{i,j}v_{k,l} \in E(\overline{G} \square \overline{H})$ is not in $G \square H$, so that each edge in $K_m \square K_n$ is in exactly one of the graphs $G \square H$ or $\overline{G} \square \overline{H}$. If an edge is in some K_m -layer of $K_m \square K_n$, then it is in either the corresponding G -layer of $G \square H$, or in the corresponding \overline{G} -layer of $\overline{G} \square \overline{H}$, and similarly for an edge in some K_n -layer of $K_m \square K_n$. Figure 1.3 shows that the union of $P_3 \square P_3$ and $\overline{P_3} \square \overline{P_3}$ yields the graph $K_3 \square K_3$, with $\pi = (v_1, v_2)$.

Figure 1.3: $P_3 \boxtimes P_3$ and $\overline{P_3} \boxtimes \overline{P_3}$, with $\pi = (v_1, v_2)$.

1.2 Survey of Recent Results

1.2.1 Vizing's Conjecture

In 1963 V.G. Vizing [70] posed the question whether the domination number (then called the *external stability number*) of the Cartesian product of any two graphs is at least as large as the product of the respective domination numbers. He posed this as a conjecture in 1968 [71] which, using modern notation for the domination number of a graph, is now known widely as Vizing's conjecture.

Conjecture 1.2.1 For any graphs G and H , $\gamma(G \square H) \geq \gamma(G)\gamma(H)$.

A graph G is said to satisfy the conjecture if $\gamma(G \square H) \geq \gamma(G)\gamma(H)$ for any graph H . Vizing [70] also established the bound $\gamma(G \square H) \leq \min\{\gamma(G)|H|, \gamma(H)|G|\}$.

The first signs of significant progress toward proving Vizing's conjecture was made in 1979, when Barcalkin and German [1] showed its validity for a large class of graphs, which they called the *A-class*: A graph G whose vertex set can be partitioned into $\gamma(G)$ cliques is *decomposable*, and the *A-class* is the family of graphs that are decomposable or can be made decomposable by adding edges without changing the domination number (in other words, all graphs G such that G is a spanning subgraph of a decomposable graph G' with the same domination number). Sufficient conditions for a graph to belong to this class were

provided. More specifically, G belongs to the A -class if $\gamma(G) = \rho_2(G)$ or $\gamma(G) = 2$, where $\rho_2(G)$ denotes the 2-packing number of G . Thus it was shown that Vizing's conjecture holds for all trees, since any tree satisfies the former condition (as proved by Meir and Moon [56]). The truth of the conjecture for trees was also obtained independently by Jacobson and Kinch [47], Faudree, Schelp and Shreve [22] and Chen, Piotrowski and Shreve [10]. Jacobson and Kinch also provided the lower bound $\gamma(G \square H) \geq \max\{\gamma(G)\rho_2(H), \rho_2(G)\gamma(H)\}$.

The class of cycles also belongs to the A -class defined by Barcalkin and German and therefore satisfies Vizing's conjecture [38]. Jacobson and Kinch [46] confirmed the truth of the conjecture independently for the product of two cycles and two paths respectively. They also verified the conjecture for any graph with domination number equal to half its order and established the lower bound $\gamma(G \square H) \geq \max\{\frac{|V(H)|}{1+\Delta(H)}\gamma(G), \frac{|G|}{1+\Delta(G)}\gamma(H)\}$. In 1991 El-Zahar and Pareek [19] proved Vizing's conjecture for the class of cycles independently by induction on the length of the cycle. They also showed the truth of the conjecture for the product $G \square \overline{G}$ and graphs with domination number 2, and established the lower bound $\gamma(G \square H) \geq \min\{|V(G)|, |V(H)|\}$.

In 1990 Faudree, Schelp and Shreve [22] defined a class of graphs containing those graphs G for which $\gamma(G) = \rho_2(G)$, among others. A graph G belongs to this class of graphs, said to satisfy *Condition CC*, if the vertex set $V(G)$ can be partitioned into $\gamma(G)$ colour classes such that any subset of at most $\gamma(G) - 1$ vertices fails to dominate some vertex in each colour not represented in the set. They showed (independent from [1]) that any graph in this class satisfies Vizing's conjecture. However, this class of graphs forms a proper subset of the A -class defined by Barcalkin and German in [1], as shown by Hartnell and Rall [38]. Similarly the class of graphs for which the domination number is equal to the so-called *extraction number*, also belongs to the A -class and is in fact equivalent to this class [38]. (Let $\mathcal{V} = \{V_1, V_2, \dots, V_k\}$ be a partition of $V(G)$. The set V_i is *covered* by a set A of vertices in G if either $V_i \cap A \neq \emptyset$ or $V_i \subseteq N(A)$. Let d_A be the number of partite sets V_i covered

by A . Then \mathcal{V} is *extracted* if $d_A \leq |A|$ for any set $A \subseteq V(G)$. The extraction number $x(G)$ is the largest order of all extracted partitions of $V(G)$.) Chen, Piotrowski and Shreve [10] defined this parameter and showed independently in 1996 that these graphs also satisfy Vizing's conjecture.

In 1991 Hartnell and Rall [36] used a constructive approach to build classes of graphs that satisfy Vizing's conjecture. Graphs containing a so-called *attachable* set of vertices were shown to satisfy the conjecture. (A nonempty set $S \subseteq V(G)$ is called an attachable set in G if and only if, for every graph H and every subset D of $V(G \square H)$ which dominates $V(G - S) \times V(H)$, $|D| \geq \gamma(G)\gamma(H)$.) For example, graphs with equal domination and 2-packing numbers all have attachable sets, while the cycle C_n has an attachable set if and only if $n \equiv 0, 2 \pmod{3}$. Large families of graphs, each containing attachable sets, can be constructed from smaller graphs with the same property. Hence these families satisfy Vizing's conjecture. In fact, any graph that satisfies Vizing's conjecture is an induced subgraph of many larger graphs that also satisfy the conjecture and have attachable sets. Hartnell and Rall also provided infinite families of graphs for which equality is attained in the conjectured bound. As one such example, if G has a *symmetric γ -set* and H has domination number half its order, then $\gamma(G \square H) = \gamma(G)\gamma(H)$. (A vertex set $D \subseteq V(G)$ is a symmetric γ -set (also known as a two-coloured γ -set) of G if it can be partitioned into two sets D_1 and D_2 such that $V(G) - N[D_1] = D_2$ and $V(G) - N[D_2] = D_1$.)

Payan and Xuong [62] were the first to provide examples of families of graphs attaining equality in Vizing's conjecture in 1982. It is easy to verify that $\gamma(G \square \overline{G}) = n$ for any graph G of order n . Therefore, the class of *domination-balanced* graphs (graphs for which $\gamma(G)\gamma(\overline{G}) = n$) attains equality in Vizing's conjectured bound. They also characterized domination-balanced graphs. Independently from Payan and Xuong, Fink, Jacobson, Kinch and Roberts [23] showed in 1985 that the 4-cycle and coronas are the only connected graphs with domination number equal to half their order. They proceeded to show that

for the Cartesian product of such graphs of order at least 4, equality is also attained in Vizing's conjecture, thereby building on the result by Jacobson and Kinch [46]. In the following year Jacobson and Kinch [47] also pursued the question of attaining equality in Vizing's conjectured bound for the Cartesian product of two trees. They concluded that at least one of the trees is a corona and deduced structural properties for the other tree in the product. Recently, El-Zahar, Khamis and Nazzal [18] showed that the equality $\gamma(C_n \square G) = \gamma(C_n)\gamma(G)$ only holds for a graph G if $n \equiv 1 \pmod{3}$. They characterized such graphs G in the case of $n = 4$. Regarding the question whether for any graph G there exists a graph H such that $\gamma(G \square H) = \gamma(G)\gamma(H)$, Hartnell [38] showed that there exist graphs for which equality can never be attained. Examples of such graphs are the 6-cycle and the star $K_{1,n}$, $n \geq 2$. In 2000 Hartnell [35] generalized the notion of a corona and examined the 2-packing number and domination number of the Cartesian product involving these graphs, to examine the excess over equality in Vizing's conjectured bound. Among other results, he showed that if both G and H are graphs for which every vertex is either a leaf or has exactly k leaves, then $\gamma(G \square H) = k\gamma(G)\gamma(H)$.

In 1995 Hartnell and Rall [37] generalized the main results by Barcalkin and German [1] from 1979. They constructed a class of graphs by way of a certain partitioning of the vertex set and showed that this class contains the A -class (defined by Barcalkin and German) as a proper subset. Hartnell and Rall showed that all graphs in this new class satisfy Vizing's conjecture. As a consequence, graphs for which the domination number and the 2-packing number differ by at most one (in other words $\gamma(G) - 1 \leq \rho_2(G) \leq \gamma(G)$) also satisfy the conjecture.

In 1998 Kang, Shan and Sun [48] claimed that Vizing's conjecture is true for any graph for which the domination number differs from the connected domination number. However, the proof of this result is not correct. In the following year Hartnell and Rall [39] improved on the lower bound of Jacobson and Kinch [47], that $\gamma(G \square H) \geq \max\{\rho_2(G)\gamma(H), \rho_2(H)\gamma(G)\}$,

by examining graphs that have 2-packings whose membership can be altered in a certain way. Furthermore, they took the first step toward answering an open question posed in [38], by showing that if a tree T contains a vertex adjacent to at least two leaves, then for any connected graph H , $\gamma(T \square H) > \gamma(T)\gamma(H)$. Another open question posed in [38] is whether there exists a constant c such that for every pair of graphs G and H , $\gamma(G \square H) \geq c\gamma(G)\gamma(H)$. In 2000 Clark and Suen [12] provided an answer by showing that $\gamma(G \square H) \geq \frac{1}{2}\gamma(G)\gamma(H)$. Hartnell and Rall [38] also posed the question whether Vizing's conjecture can be verified for all graphs G such that $\gamma(G) \leq 3$. Since the truth of the conjecture had already been verified for graphs with domination number 1 or 2, the only case that remained open is when $\gamma(G) = 3$. Progress toward answering this question was achieved by Brešar [3] in 2001, showing that Vizing's conjecture is true for every pair of graphs G and H such that $\gamma(G) = \gamma(H) = 3$. In 2004 Sun [68] answered this open question completely by verifying the conjecture for any graph that has domination number equal to 3.

In 2003 Clark, Ismail and Suen [13] showed that Vizing's conjecture is true in almost all cases if both graphs are k -regular graphs. Furthermore they provided a range for both the minimum and maximum degree of the graphs involved, so as to satisfy the conjecture. In particular it was shown that Vizing's conjecture is satisfied for pairs of graphs of order at most n and minimum degrees at least $\sqrt{n} \ln n$. In the same year Hartnell and Rall [40] improved on some of the known upper and lower bounds on the domination number of the Cartesian product of two graphs in terms of the product of the respective domination numbers. While Vizing's conjecture is known to be true if one of the graphs is a tree, they improved the bound for the case of two isomorphic trees T , by showing that $\gamma(T \square T) \geq \gamma(T)\gamma(T) + (|T| - 2\gamma(T))$.

1.2.2 Domination of Cartesian Products

In addition to the study of classical domination on Cartesian product graphs specifically relating to Vizing's conjecture, significant research has been conducted on determining the parameter values for this graph product, with emphasis on the product of two paths or cycles.

In 1984 Jacobson and Kinch [46] considered the Cartesian product of two paths, also known as the *complete grid graph*, and determined the domination number when one of the paths has order 2, 3 or 4. They also studied the asymptotic behaviour of the domination number for the product of any two paths. Gravier and Mollard [28] extended these results by establishing asymptotic values for the domination number of the Cartesian product of any number of paths. In 1985 Cockayne, Hare, Hedetniemi and Wimer [14] improved on the bounds given by Jacobson and Kinch, while also providing some exact results for the domination number of $n \times n$ grid graphs. Furthermore, they suggested an improved general bound. While Fisher used a dynamic programming approach to determine upper bounds for the $n \times m$ grid graph, Chang also established an upper bound for the case when $n, m \geq 8$ (see [32]). In 2001 Chérifi, Gravier and Zighed [11] responded to an open question mentioned in [14] by improving the difference between the general lower and upper bounds for the domination number of $n \times n$ grid graphs.

In 1986 Hare, Hare and Hedetniemi [33] constructed a linear time algorithm for finding the domination number of a grid graph, while Klavžar and Žerovnik [51] proposed an $O(\log n)$ algorithm. Singh and Pargas [66] proceeded in 1987 to conjecture closed form expressions for the domination number of the grid graph when one of the paths has order 5, 7, 8 or 9, and also described a parallel algorithm for determining its domination number. In 1993 Chang and Clark [7] determined the values of $\gamma(P_5 \square P_n)$ and $\gamma(P_6 \square P_n)$. Extending these results, Chang, Clark and Hare [8] improved on the known upper bounds for the domination numbers $\gamma(P_k \square P_n)$, $k = 7, 8, 9, 10$ and any n . They also conjectured that these bounds

are in fact the actual domination numbers. According to [73], formulas for the domination number are known for values k up to 19.

In 2004 Guichard [32] improved on the known lower bound for the domination number of grid graphs. When compared with the best known upper bound for large enough $n \times m$ grid graphs, the difference between these bounds was reduced to 5.

As stated in [34], Hare derived formulas for the domination numbers $\gamma(C_k \square P_n)$ for $k \leq 12$ and $\gamma(C_k \square C_n)$ for $k \leq 7$ from a computer algorithmic study of these parameters. In 1993 Hare and Hare [34] proved these formulas for values of k up to 5 and 4 respectively. Considering the Cartesian product of cycles, Klavžar and Seifter [50] determined the domination number for the product of multiple cycles, given certain conditions on the cycle lengths. They also determined independently the domination number of the product of two cycles $C_k \square C_n$ (also called the $k \times n$ toroidal grid graph) when one cycle has length $k = 3, 4$ or 5, except for the case $k = 5$ and $n \equiv 3 \pmod{5}$, which was proved by Žerovnik [72]. Furthermore, they noted that a similar asymptotic value for this product follows directly from the corresponding result for paths by Jacobson and Kinch [46], and also stated an obvious upper bound for the domination number of the toroidal grid graph. El-Zahar and Shaheen [20] extended their previous work on the cases $k = 6$ and 7 (mentioned in [65]) by determining the domination numbers for the Cartesian product of two cycles when one has length 8 or 9. In 2000 Shaheen [65] extended the known results on these domination numbers by establishing the parameter value of the product $C_{10} \square C_n$. El-Zahar and Shaheen [21] provided an improved general upper bound on the domination number of $C_k \square C_n$ by considering the various residue classes of k modulo 5. In 2002 Ghaleb and Shaheen [29] presented two algorithms for determining the domination number of $k \times n$ toroidal grid graphs. The algorithms produce a minimum dominating set in some cases, thereby providing the domination number.

However, in 1994 Livingston and Stout [55] obtained a constant time algorithm to de-

termine the domination number and minimum dominating sets of the Cartesian products $G \square P_n$, when considering a fixed graph G . They also showed how one can obtain closed form expressions for the domination number of such graphs, as well as determining all the possible minimum dominating sets. Furthermore, they claimed that the method can also be extended to the product of a graph with a cycle or a k -ary tree.

In 2004 Hartnell and Rall [41] investigated the domination of the prism $G \square K_2$ of a graph G . Their investigation focused on graphs that attain the known general upper and lower bounds for the domination number of such graphs, namely $\gamma(G) \leq \gamma(G \square K_2) \leq 2\gamma(G)$ for any graph G . In each case, they provided an infinite class of graphs to show that the bounds are sharp. Burger, Mynhardt and Weakley [5] also considered graphs G for which the domination number $\gamma(G \square K_2)$ of the prism equals the trivial upper bound of $2\gamma(G)$, calling such graphs *prism doublers*. They proceeded to characterize these graphs, while also considering prism doublers that are regular and have efficient dominating sets. Considering the lower bound, Hartnell and Rall [41] also investigated graphs G for which the domination number of the prism of G is equal to the domination number of G . Such graphs are called *prism fixers*, and they characterized these graphs as graphs that contain a symmetric γ -set (also known as a two-coloured γ -set).

1.2.3 Other Graph Products

Domination of Associative Graph Products and Vizing-like inequalities

Vizing's conjecture suggests a possible relationship between the domination number of the Cartesian product of two graphs and the product of the domination numbers of the respective graphs. An interesting question is whether a similar inequality holds for other well-known graph products. Imrich and Izbicki [45] determined that there are only 10 different associative graph products, with vertex sets the Cartesian product of the respective

sets, that depend on the edge structure of both graphs, while 8 of these are also commutative. Reducing these to 9 different graph products, Nowakowski and Rall [61] examined the relationship between the domination number of the graph product and the product of the respective domination numbers, and also considered other graph parameters. They determined that for any graphs G and H , $\gamma(G \otimes H) \leq \gamma(G)\gamma(H)$, where \otimes denotes any of the six different graph products known as the strong, lexicographic, co-categorical, co-Cartesian, disjunction and equivalence graph product. Furthermore, counterexamples were provided showing that no single inequality holds for the domination number of the categorical product and symmetric difference respectively. In 1994 Fisher [24] established independently the inequality $\gamma(G \boxtimes H) \leq \gamma(G)\gamma(H)$ for the strong product of any two graphs G and H . Besides confirming Vizing's conjecture, the issue of characterizing graphs that satisfy one of the inequalities remains in the case of the categorical product or symmetric difference of two graphs. In 1995 Gravier and Khelladi [28] considered the domination number of the categorical product of a path with the complement of a path, and established that $\gamma(P_k \times \overline{P}_n) \leq \gamma(P_k)\gamma(\overline{P}_n)$ for $k > 1$ and $n > 3$. They (incorrectly) conjectured that a similar inequality holds in general. Nowakowski and Rall disproved this conjecture, as stated above, and Klavžar and Zmazek [52] also provided specific examples by showing that for any k , there exists a graph G such that $\gamma(G \times G) \leq \gamma(G)^2 - k$.

Domination of Generalized Prism Graphs

In 1967 Chartrand and Harary [9] introduced the notion of a *generalized prism graph* (then called a *permutation graph*). For a graph G and permutation π of $V(G)$, the generalized prism graph πG is obtained from two disjoint copies G_1 and G_2 of G , along with edges joining each v in G_1 with $\pi(v)$ in G_2 . In 2004 Burger, Mynhardt and Weakley [5] initiated the study of domination of generalized prism graphs. Noting the obvious bounds $\gamma(G) \leq \gamma(\pi G) \leq 2\gamma(G)$, they considered graphs which attain the upper bound for some

permutation (calling such graphs *partial doublers*) or for any permutation (calling such graphs *universal doublers*). Besides providing a characterization of universal doublers, they derived degree properties of such graphs and provided specific examples using circulants. Regarding partial doublers, they constructed a large class of graphs to illustrate that there exist graphs G for which the domination number $\gamma(\pi G)$ may equal every value from $\gamma(G)$ to $2\gamma(G)$, for suitable choices of π . Graphs attaining the lower bound for every permutation are called *universal fixers*. In 2006 Mynhardt and Xu [59] conjectured that only the edgeless graphs have this property. As a first step toward proving this, they confirmed their conjecture for k -regular graphs, $k \leq 4$, graphs with minimum degree less than 3, and graphs with domination number at most 3. Gibson and Mynhardt [25] confirmed the conjecture for 5-regular graphs and k -regular bipartite graphs, while Gibson [26] showed that nontrivial graphs without 5-cycles are not universal fixers. As a consequence, the conjecture is also confirmed for bipartite graphs. Cockayne, Gibson and Mynhardt [15] proved that claw-free graphs are not universal fixers, and Burger and Mynhardt [6] showed that regular graphs and graphs with domination number equal to 4 are not universal fixers.

Generalizations of the Cartesian Product

Various graph structures have been defined that might serve as possible generalizations to the Cartesian product of two graphs. The remaining paragraphs of this section survey these definitions and discuss similarities to the generalized Cartesian product defined in Section 1.1.

Multipermutation Graphs In 1988 Gionfriddo, Milazzo and Vacirca [30] introduced so-called *multipermutation graphs* as a generalization of the generalized prism graphs defined by Chartrand and Harary [9]. Let G be an order m graph with vertices labelled v_1, v_2, \dots, v_m and let $A_n = \{\pi_{ij} \in S_m : 1 \leq i < j \leq n\}$ be $\binom{n}{2}$ permutations on the set $\{1, 2, \dots, m\}$.

The multipermutation graph $P_{A_n}(G)$ of G with respect to A_n is the graph consisting of n disjoint copies G_1, G_2, \dots, G_n of G , with additional edges joining vertex v in G_i with $\pi_{ij}(v)$ in G_j . The authors establish sharp bounds for the chromatic number of such graphs. In 1991 they investigate the chromatic number of the subclass of transitive multipermutation graphs [31]. In this case the permutations in A_n have the added property that for each $1 \leq i < j < k \leq n$, $\pi_{ik} = \pi_{jk}\pi_{ij}$, where multiplication occurs from right to left. For transitive multipermutation graphs, the $\binom{n}{2}$ permutations determine a partition of the vertex set into m cliques, each clique containing exactly one vertex from each copy of G . For the case $n = 2$, these graphs are generalized prism graphs. The generalized products $G \boxtimes H$ are (transitive) multipermutation graphs only when H is complete.

Other Generalized Prisms In 1992 Hobbs, Lai, Lai and Weng [44] also used the term *generalized prism* to define a more general prism graph. Given two disjoint graphs G_1 and G_2 of order m and a k -regular bipartite graph B having the sets $V(G_1)$ and $V(G_2)$ as its partite sets, the graph $G_1 \cup G_2 \cup B$ obtained from the union of G_1 , G_2 and B (union of the vertex and edge sets respectively) was called a generalized prism $A_k(G_1, G_2)$ over G_1 and G_2 . In the case where $k = 1$ and $G_1 \cong G_2$, the graph B corresponds to a permutation $\pi \in S_m$ and this graph product reduces to the generalized prism graph introduced by Chartrand and Harary [9]. The authors used their newly defined graph to construct uniformly dense graphs.

Fasciagraphs and Rotagraphs As mentioned previously, Klavžar and Žerovnik [51] proposed an $O(\log n)$ algorithm for finding a minimum dominating set of a complete grid graph. Their approach was to investigate this problem, as well as determine the independence number, on *fasciagraphs* and *rotagraphs*, which are graph structures that generalize the Cartesian product, but form special cases of *polygraphs*. Let G_1, G_2, \dots, G_n be n mutually disjoint graphs and let X_i be a set of edges joining vertices in G_i to those in G_{i+1} .

(For convenience let G_{n+1} also denote G_1 .) A polygraph is defined as a graph with vertex set the union of all vertices of the graphs G_i , and edge set the union of all the edges in each graph, as well as all edges in the sets X_i . For the special case where all the graphs are isomorphic to a fixed graph G (with identical vertex labellings) and the additional edge sets are all identical to a set X , the polygraph is called a rotagraph. A fasciagraph is a rotagraph without edges between the first and last copy of G . It was noted in [51] that the Cartesian product $P_m \square P_n$ is a fasciagraph, while the graph $C_m \square C_n$ is a rotagraph. It is clear that for any G and permutation π of $V(G)$, the generalized product graphs $G \boxtimes P_n$ and $G \boxtimes C_n$ are included in the definition of fasciagraphs and rotagraphs respectively.

Graph Bundles In 1983, Pisanski, Shawe-Taylor and Vrabec [63] introduced the notion of a *graph bundle* in a graph theoretic manner, and studied the edge-colourability of these graphs. A (*Cartesian*) *graph bundle* $B \times^\phi F$ with fibre F over the base graph B is the graph obtained by replacing each vertex in B by a copy of F and for each edge in B , assigning a matching between the corresponding copies of F , according to a mapping $\phi : E(B) \rightarrow \text{Aut}(F)$. The Cartesian product $B \square F$ is obtained as a special case, when ϕ maps each edge to the identity automorphism of F . A generalized Cartesian product $G \boxtimes H$ is a graph bundle $H \times^\phi G$ if and only if $\pi \in \text{Aut}(G)$ (when the graph is a Cartesian product). As an example, it is verified easily that the graph bundle $C_3 \times^\phi C_4$ shown in Figure 1.4 is not a generalized Cartesian product $C_4 \boxtimes C_3$ for any π . Kwak and Lee [53] investigated isomorphism classes of graph bundles, specifically related to so-called natural isomorphisms, where a fibre in one graph bundle maps to a fibre in the other. They provided a characterization for when two graph bundles are isomorphic in this fashion. In 2006, Zmazek and Žerovnik [73] considered the domination number of graph bundles. They investigated the domination number of graph bundles of two cycles when the fibre is a cycle of length 3 or 4. They also provided examples showing that a Vizing-like inequality does not hold in general for this graph product.

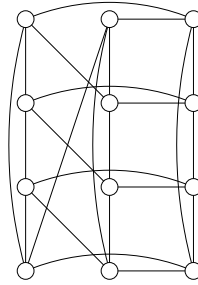


Figure 1.4: A graph bundle $C_3 \times^\phi C_4$ that is not a generalized Cartesian product $C_4 \boxtimes C_3$ for any π .

Permutation Graphs over a Graph In 1995, Lee and Sohn [54] proposed a graph product that generalizes the notion of both graph bundles and generalized prisms. A G -permutation graph over H with respect to ϕ , denoted $H \bowtie^\phi G$, is the graph obtained by replacing each vertex in H by a copy of G and for each edge in H , assigning a matching between the corresponding copies of G , according to a mapping $\phi : E(H) \rightarrow S_{|V(G)|}$. If ϕ maps all edges of H to $\text{Aut}(G)$, then this graph is a graph bundle. If $H = K_2$, then the graph is a generalized prism. It is clear that the family of G -permutation graphs over H contains the family of generalized Cartesian products $G \boxtimes H$. Lee and Sohn [54] investigated when two G -permutation graphs over H are isomorphic by a natural isomorphism and obtained a characterization similar to that of Kwak and Lee [53] in the case of graph bundles.

Generalization Hierarchy Figure 1.5 shows how the various graph products surveyed here relate to each other and to the generalized Cartesian product defined in Section 1.1. A family \mathcal{F} of graphs is shown as being connected to another family \mathcal{G} if \mathcal{F} is contained in \mathcal{G} (in other words \mathcal{G} is a generalization of \mathcal{F}).

1.3 Thesis Overview

This document consists of five chapters, in addition to this introductory chapter.

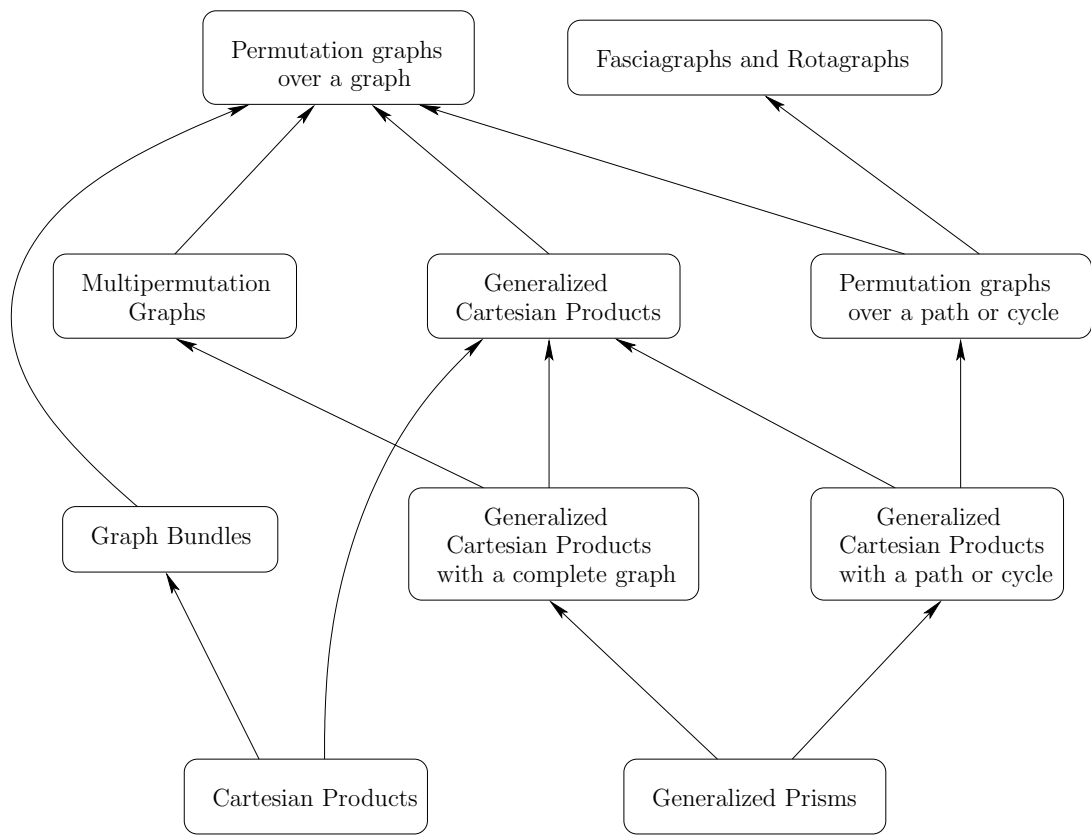


Figure 1.5: A diagram showing the relationships between the various graph products.

Chapter 2 initiates the study of the generalized Cartesian product defined in Section 1.1. It starts by investigating when two generalized Cartesian products are isomorphic by a so-called natural isomorphism. Next, the diameter of the generalized Cartesian product is examined and compared to that of the corresponding Cartesian product graph. Lastly, the validity of an inequality similar to Vizing's conjecture for Cartesian products is explored briefly, further motivating the study of generalized Cartesian product graphs.

Chapter 3 concerns the study of so-called product multipliers and fixers. Graphs G for which the domination number of the Cartesian product $G \square K_n$ of G with a complete graph is equal to the established lower bound, are known as Cartesian fixers. Graphs attaining equality in the upper bound are known as Cartesian multipliers. The chapter starts by characterizing the various types of Cartesian fixers, as well as Cartesian multipliers. When considering the generalized Cartesian product, graphs G for which the domination number of $G \boxtimes H$ is equal to the established lower bound for any permutation, are called universal fixers. Graphs attaining equality in the upper bound for all permutations are called universal multipliers. The chapter proceeds to characterize universal multipliers for H a complete graph, and also investigates the case where H is a cycle. Universal fixers are also discussed briefly.

Building on an efficient algorithm by Livingston and Stout [55] for determining the domination number of $G \square P_n$ (the Cartesian product of a graph with a path) a general framework to determine $\gamma(G \square H)$ for any graph H is introduced in Chapter 4. Its use in determining the domination number of the generalized Cartesian product $G \boxtimes H$ is also illustrated.

In Chapter 5, the study diverts from the main topic of domination to investigate the planarity of the generalized Cartesian product graph. A well-known planarity testing algorithm by Demoucron, Malgrange and Pertuiset [16] is reviewed, and used to establish conditions for when a generalized Cartesian product is planar.

The document concludes with a summary of the results achieved. In addition, various open

problems encountered through the course of the study are summarized.

Chapter 2

A Preliminary Investigation

2.1 Introduction

An initial study of the generalized Cartesian product defined in Section 1.1 is conducted in this chapter. In Section 2.2, the natural isomorphisms between two generalized Cartesian product graphs are explored. The characterization of Lee and Sohn [54] is applied to this graph product and various corollaries are discussed. Section 2.3 explores the diameter of the generalized Cartesian product, comparing it to that of the corresponding Cartesian product graph. Conditions are discussed under which the respective diameters are equal. Lastly, in Section 2.4 the validity of an inequality similar to Vizing's conjecture for Cartesian products is explored briefly, further motivating the study of generalized Cartesian product graphs. Various results are provided to illustrate the relationship between the domination number of a generalized Cartesian product and the domination numbers of the respective graphs.

2.2 Natural Isomorphisms

Let G be a graph and π a permutation of $V(G) = \{v_1, v_2, \dots, v_m\}$. Consider two generalized prisms αG and πG , and let V_j denote the vertex set of the j^{th} G -layer, $j = 1, 2$. The graphs αG and πG are said to be isomorphic by a *positive natural isomorphism* ϕ if $\phi(V_j) = V_j$ for $j = 1, 2$, and by a *negative natural isomorphism* if $\phi(V_1) = V_2$, $\phi(V_2) = V_1$. Generalized prisms isomorphic by a positive or negative natural isomorphism are said to have a *natural isomorphism*. Dorfler [17] and Hedetniemi [43] both gave the following characterization for two generalized prisms to be isomorphic by a natural isomorphism.

Theorem 2.2.1 [17], [43] *For a graph G and two permutations α, π of $V(G)$, $\alpha G \cong \pi G$ by a*

(i) *positive natural isomorphism if and only if $\pi \in \text{Aut}(G)\alpha\text{Aut}(G)$;*

(ii) *negative natural isomorphism if and only if $\pi \in \text{Aut}(G)\alpha^{-1}\text{Aut}(G)$. ■*

As an example, consider the permutations $\alpha = (v_3, v_4, v_5)$ and $\pi = (v_1, v_2, v_3, v_5, v_4)$ of the vertices of $G = C_5$, canonically labelled. It is verified easily that $\pi \in \text{Aut}(G)\alpha\text{Aut}(G)$, so that $\alpha G \cong \pi G$ by a positive natural isomorphism by Theorem 2.2.1. These generalized prisms are illustrated in Figure 2.1 and an isomorphism $\phi : V(\alpha G) \mapsto \pi G$ is given by $\phi(v_{i,1}) = v_{i,1}$ and $\phi(v_{i,2}) = v_{i+1,2}$, with $i = 1, 2, \dots, 5$; addition on the subscripts is performed modulo 5.

Two generalized prisms αG and πG may not be isomorphic by a natural isomorphism, but by some other isomorphism instead. Consider αC_8 and πC_8 with $\alpha = (v_3, v_4, v_6, v_5, v_8)$ and $\pi = (v_3, v_4, v_7, v_6, v_8)$. It can be verified by way of Theorem 2.2.1 that these generalized prisms are not isomorphic by a natural isomorphism. However, an isomorphism $\phi : \alpha C_8 \mapsto \pi C_8$ is provided in Table 2.1. This is also illustrated in Figure 2.2, with αC_8 shown in

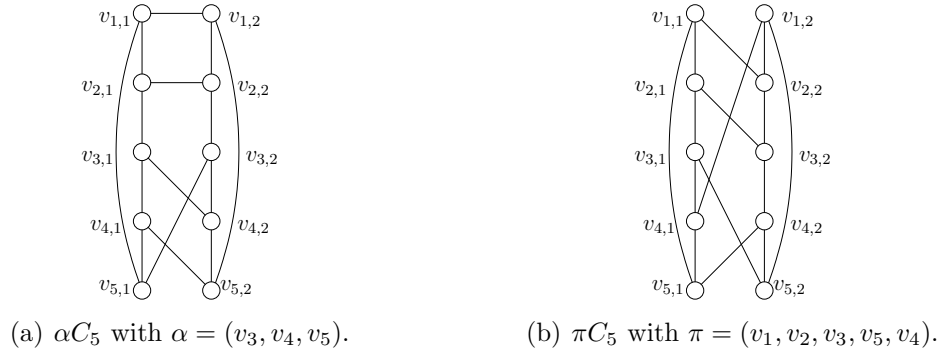


Figure 2.1: Isomorphic generalized prisms αC_5 and πC_5 .

Figure 2.2(a). In Figure 2.2(b), the vertices of αC_8 that map to πC_8 under ϕ are shown in brackets. Also, the image of the first C_8 -layer of αC_8 is shown by thick edges, the image of the second C_8 -layer of αC_8 is shown by thin edges, while the image of the remaining edges are shown as dashed edges.

$v_{1,1} \mapsto v_{1,1}$	$v_{2,1} \mapsto v_{2,1}$	$v_{3,1} \mapsto v_{3,1}$	$v_{4,1} \mapsto v_{4,1}$
$v_{5,1} \mapsto v_{7,2}$	$v_{6,1} \mapsto v_{6,2}$	$v_{7,1} \mapsto v_{7,1}$	$v_{8,1} \mapsto v_{8,1}$
$v_{1,2} \mapsto v_{1,2}$	$v_{2,2} \mapsto v_{2,2}$	$v_{3,2} \mapsto v_{3,2}$	$v_{4,2} \mapsto v_{4,2}$
$v_{5,2} \mapsto v_{5,2}$	$v_{6,2} \mapsto v_{5,1}$	$v_{7,2} \mapsto v_{6,1}$	$v_{8,2} \mapsto v_{8,2}$

Table 2.1: An isomorphism $\phi : \alpha C_8 \mapsto \pi C_8$.

To see that the condition in Theorem 2.2.1 is not sufficient for two generalized Cartesian products to be isomorphic by a (positive) natural isomorphism, again consider $G \boxtimes H$ and $G \boxtimes H$ for $\alpha = (v_3, v_4, v_5)$ and $\pi = (v_1, v_2, v_3, v_5, v_4)$, with $G = C_5$ and $H = P_3$. These products are illustrated in Figure 2.3 (not all labels are shown). It can be verified easily that $C_5 \boxtimes P_3$ is not isomorphic to $C_5 \boxtimes P_3$, even though $\pi \in \text{Aut}(C_5)\alpha\text{Aut}(C_5)$.

Consider the generalized Cartesian product $G \boxtimes H$. For the sake of convenience, the permutation π of $V(G)$ may be viewed as an element of S_m acting on the subscripts of the vertex labels v_1, v_2, \dots, v_m of G . The notation $\pi(v_i) = v_j$ and $v_{\pi(i)} = v_j$ will be used interchangeably. Similar notation will be used for a permutation $h \in \text{Aut}(H)$.

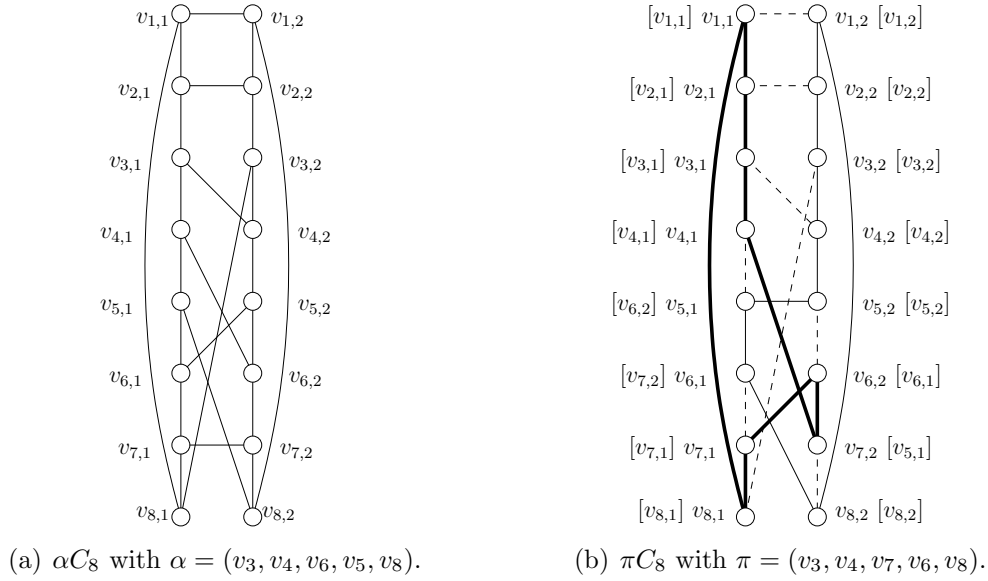


Figure 2.2: Isomorphic generalized prisms αC_8 and πC_8 .

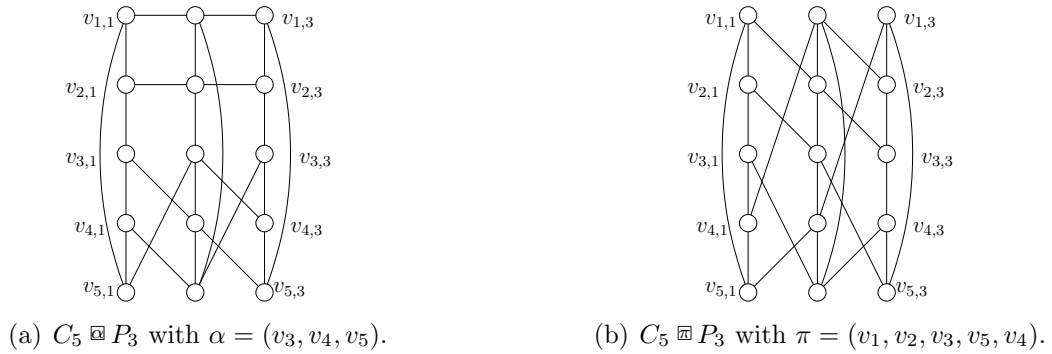


Figure 2.3: Nonisomorphic generalized Cartesian products $C_5 \boxtimes P_3$ and $C_5 \boxtimes P_3$.

Theorem 2.2.2 provides a characterization (similar to the result by Lee and Sohn [54]) for when two generalized Cartesian products are isomorphic by a natural isomorphism. It is preceded by an informal discussion. Consider $G \boxtimes H$ and $G \boxtimes H$, with vertex sets $\{(v_i, u_j) : i = 1, 2, \dots, m, j = 1, 2, \dots, n\}$, and let G_j denote the G -layer corresponding to u_j in the respective graphs, with vertex set $V_j = V(G_j)$. The product $G \boxtimes H$ is said to be isomorphic to $G \boxtimes H$ by a *natural isomorphism* ϕ if for any $i \in \{1, 2, \dots, n\}$, $\phi(V_i) = V_j$ for some $j \in \{1, 2, \dots, n\}$.

Suppose $G \boxtimes H \cong G \boxtimes H$ by a natural isomorphism. Then there exists an automorphism $h \in \text{Aut}(H)$ that prescribes the G -layer in $G \boxtimes H$ to which a G -layer G_j in $G \boxtimes H$ maps. In other words, V_j maps to $V_{h(j)}$ for $j = 1, 2, \dots, n$. Consider a vertex $(v_i, u_j) \in V_j$ in $G \boxtimes H$. Let $k \in \{1, 2, \dots, n\}$ and consider the set V_k in $G \boxtimes H$ corresponding to $u_k \in V(H)$. There is exactly one vertex, namely $(v_{\alpha^{k-j}(i)}, u_k)$, that is in both V_k and the same H -layer as (v_i, u_j) in $G \boxtimes H$. This vertex $(v_{\alpha^{k-j}(i)}, u_k)$ maps to some vertex in $G_{h(k)}$ in $G \boxtimes H$, according to some automorphism $g_k \in \text{Aut}(G)$ that maps V_k in $G \boxtimes H$ to $V_{h(k)}$ in $G \boxtimes H$ under the natural isomorphism. So vertex $(v_{\alpha^{k-j}(i)}, u_k)$ maps to $(v_{g_k \alpha^{k-j}(i)}, u_{h(k)})$ in $G \boxtimes H$. Observe that under a natural isomorphism, an H -layer in $G \boxtimes H$ maps to an H -layer in $G \boxtimes H$. The strategy is to

- map (v_i, u_j) in V_j to the vertex $(v_{\alpha^{k-j}(i)}, u_k)$ in V_k (and the same H -layer in $G \boxtimes H$),
- then map this vertex $(v_{\alpha^{k-j}(i)}, u_k)$ in $G \boxtimes H$ to $(v_{g_k \alpha^{k-j}(i)}, u_{h(k)})$ in $G \boxtimes H$ under the appropriate automorphism $g_k \in \text{Aut}(G)$, and lastly
- map $(v_{g_k \alpha^{k-j}(i)}, u_{h(k)})$ to the vertex that is in both $G_{h(j)}$ in $G \boxtimes H$ and the same H -layer in $G \boxtimes H$.

This vertex is $(v_{\pi^{h(j)-h(k)} g_k \alpha^{k-j}(i)}, u_{h(k)})$ in $G \boxtimes H$. But since the natural isomorphism between $G \boxtimes H$ and $G \boxtimes H$ defines an automorphism $g_j \in \text{Aut}(G)$ when restricted to V_j in $G \boxtimes H$, it holds that $\pi^{h(j)-h(k)} g_k \alpha^{k-j} = g_j$ or $\pi^{h(j)-h(k)} g_k = g_j \alpha^{j-k}$. This is illustrated in Figure 2.4.

Theorem 2.2.2 *For two graphs G and H of order m and n respectively and permutations α, π , $G \boxtimes H \cong G \boxtimes H$ by a natural isomorphism if and only if there exists an $h \in \text{Aut}(H)$ and $g_1, g_2, \dots, g_n \in \text{Aut}(G)$ such that $\pi^{h(j)-h(i)} g_i = g_j \alpha^{j-i}$ for every i, j such that $u_i u_j \in E(H)$.*

Proof: Suppose there exists an $h \in \text{Aut}(H)$ and $g_1, g_2, \dots, g_n \in \text{Aut}(G)$ with the property that $\pi^{h(j)-h(i)} g_i = g_j \alpha^{j-i}$ for every i, j such that $u_i u_j \in E(H)$. Define a bijection $\phi : V(G \boxtimes H) \mapsto V(G \boxtimes H)$ by $\phi(v_i, u_j) = (v_{g_j \alpha^{j-i}}, u_{h(j)})$, $i = 1, 2, \dots, m$, $j = 1, 2, \dots, n$.

The bijection ϕ is a natural isomorphism: Clearly, for any $i = 1, 2, \dots, n$, $\phi(V_i) = V_j$ for some $j \in \{1, 2, \dots, n\}$. Two cases are considered for the edges in $G \boxtimes H$.

(i) Suppose $(v_i, u_j), (v_k, u_j) \in V_j$ for some $j \in \{1, 2, \dots, n\}$. Then

$$\begin{aligned}
(v_i, u_j)(v_k, u_j) &\in E(G \boxtimes H) \\
&\Leftrightarrow v_i v_k \in E(G) \\
&\Leftrightarrow v_{g_j(i)} v_{g_j(k)} \in E(G) \\
&\Leftrightarrow (v_{g_j(i)}, u_{h(j)})(v_{g_j(k)}, u_{h(j)}) \in E(G \boxtimes H) \\
&\Leftrightarrow \phi(v_i, u_j) \phi(v_k, u_j) \in E(G \boxtimes H).
\end{aligned}$$

(ii) Suppose $(v_i, u_j) \in V_j$ and $(v_k, u_l) \in V_l$, with $l \neq j$. Then

$$\begin{aligned}
(v_i, u_j)(v_k, u_l) &\in E(G \boxtimes H) \\
&\Leftrightarrow u_j u_l \in E(H) \text{ and } v_k = v_{\alpha^{l-j}(i)} \\
&\Leftrightarrow u_{h(j)} u_{h(l)} \in E(H) \text{ and } v_{g_l(k)} = v_{g_l \alpha^{l-j}(i)} \\
&\Leftrightarrow u_{h(j)} u_{h(l)} \in E(H) \text{ and } v_{g_l(k)} = v_{\pi^{h(l)-h(j)} g_j(i)} \\
&\Leftrightarrow (v_{g_j(i)}, u_{h(j)})(v_{g_l(k)}, u_{h(l)}) \in E(G \boxtimes H) \\
&\Leftrightarrow \phi(v_i, u_j) \phi(v_k, u_l) \in E(G \boxtimes H).
\end{aligned}$$

It follows that ϕ is a natural isomorphism.

Conversely, suppose $G \boxtimes H \cong G \boxtimes H$ by a natural isomorphism ϕ and let $g_j = \phi|_{V_j}$ (ϕ restricted to V_j) for $j = 1, 2, \dots, n$. Then $g_j \in \text{Aut}(G)$ for every j , since V_j induces a G -layer in $G \boxtimes H$ and $\phi(V_j) = V_{h(j)}$ for some $h \in \text{Aut}(H)$. Consider arbitrary $v_i \in V(G)$ and $u_j u_l \in E(H)$. If $(v_i, u_j)(v_k, u_l) \in E(G \boxtimes H)$, then $v_k = v_{\alpha^{l-j}(i)}$. Also, since ϕ is an isomorphism, $\phi(v_i, u_j) \phi(v_k, u_l) \in E(G \boxtimes H)$, so that $(v_{g_j(i)}, u_{h(j)})(v_{g_l(k)}, u_{h(l)}) \in E(G \boxtimes H)$.

Therefore $v_{g_l(k)} = v_{\pi^{h(l)-h(j)}g_j(i)}$, or $v_{g_l\alpha^{l-j}(i)} = v_{\pi^{h(l)-h(j)}g_j(i)}$. So $g_l\alpha^{l-j} = \pi^{h(l)-h(j)}g_j$ for any j, l such that $u_j u_l \in E(H)$. ■

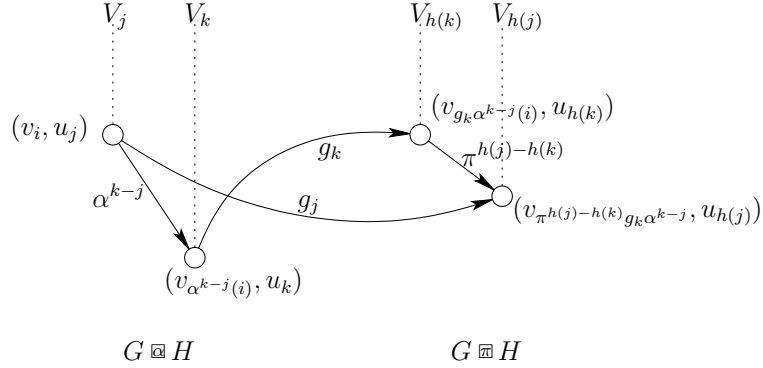


Figure 2.4: A natural isomorphism between two generalized Cartesian products $G \boxtimes H$ and $G \boxdot H$.

The following corollary provides a necessary condition (similar to that stated in Theorem 2.2.1) for two generalized Cartesian products to be isomorphic by a natural isomorphism.

Corollary 2.2.1 *Let G and H be two graphs of order m and n respectively and α, π be permutations of $V(G)$. If $G \boxtimes H \cong G \boxdot H$ by a natural isomorphism, then there exists an $h \in \text{Aut}(H)$ such that $\pi^{h(j)-h(i)} \in \text{Aut}(G)\alpha^{j-i}\text{Aut}(G)$ for every i, j such that $u_i u_j \in E(H)$.*

Proof: By Theorem 2.2.2, there exist an $h \in \text{Aut}(H)$ and $g_1, g_2, \dots, g_n \in \text{Aut}(G)$ such that $\pi^{h(j)-h(i)}g_i = g_j\alpha^{j-i}$ for every i, j such that $u_i u_j \in E(H)$. It follows that $\pi^{h(j)-h(i)} \in \text{Aut}(G)\alpha^{j-i}\text{Aut}(G)$ for every i, j such that $u_i u_j \in E(H)$. ■

To see that the condition stated in Corollary 2.2.1 is not sufficient, consider the permutations $\alpha = (v_3, v_4, v_5)$ and $\pi = (v_1, v_2, v_3, v_5, v_4)$ of $V(C_5)$ again. For h the identity automorphism of P_3 , $\pi^i \in \text{Aut}(C_5)\alpha^i\text{Aut}(C_5)$ for $i = -2, -1, 1, 2$. So the condition in Corollary 2.2.1 is satisfied. However, the generalized Cartesian products $C_5 \boxtimes P_3$ and $C_5 \boxdot P_3$ are not isomorphic.

For generalized Cartesian products, $G \boxtimes H$ is isomorphic to $G \boxplus H$ by a *positive natural isomorphism* ϕ if $\phi(V_i) = V_i$ for each $i = 1, 2, \dots, n$. A characterization for when two generalized Cartesian products are isomorphic by a positive natural isomorphism follows directly from Theorem 2.2.2.

Corollary 2.2.2 *For two graphs G and H of order m and n respectively and permutations α, π , $G \boxtimes H \cong G \boxplus H$ by a positive natural isomorphism if and only if there exist $g_1, g_2, \dots, g_n \in \text{Aut}(G)$ such that $\pi^{j-i} g_i = g_j \alpha^{j-i}$ for every i, j such that $u_i u_j \in E(H)$. ■*

The above corollary confirms that the generalized Cartesian product $G \boxplus H$ is isomorphic to the Cartesian product $G \square H$ if the permutation π is an automorphism of G .

Corollary 2.2.3 *For two graphs G, H and $\pi \in \text{Aut}(G)$, $G \boxplus H \cong G \square H$.*

Proof: Suppose H has order n and let $g_i = \pi^i$, $i = 1, 2, \dots, n$. Then $G \square H \cong G \boxplus H$ by a positive natural isomorphism by Corollary 2.2.2. ■

Observe that the set of generalized Cartesian product graphs $G \boxplus H$ depends on the labelling of $V(H)$. Suppose G' is obtained from G by a relabelling of the vertex set, and that $\phi_G : V(G) \mapsto V(G')$ is the corresponding automorphism. There exists a permutation α (for example $\alpha = \phi_G \pi \phi_G^{-1}$) such that $G' \boxplus H \cong G \boxplus H$. The labelling of $V(G)$ is therefore arbitrary, in that the set of all generalized Cartesian products $G \boxplus H$, when π is a permutation of $V(G)$, is the same as the set of all generalized Cartesian products $G' \boxplus H$, where α is a permutation of $V(G')$. However, the same does not hold for H . Let H be the path of order 3, with vertices canonically labelled u_1, u_2, u_3 , and let H' be obtained from H by interchanging the labels u_1 and u_2 . The generalized Cartesian products $G \boxplus H$ and $G \boxplus H'$, with $G = P_3$ and $\pi = (v_1, v_2)$, are shown in Figure 2.5. It may be verified easily that $G \boxplus H' \not\cong G \boxplus H$ for any permutation α of $V(G)$. In the case of $H = K_n$, the vertex labelling is arbitrary. For H a path or a cycle, a canonical labelling is primarily considered.

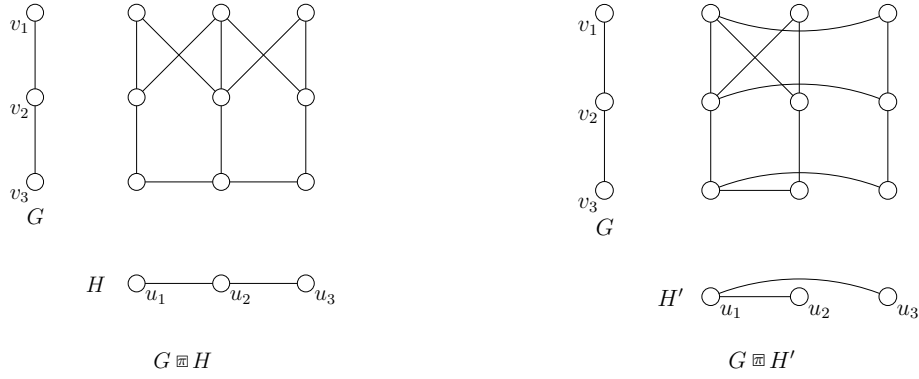


Figure 2.5: The nonisomorphic generalized Cartesian products $G \square H$ and $G \square H'$, where $\pi = (v_1, v_2)$.

For connected graphs H , the characterization in Theorem 2.2.2 may be stated as follows.

Corollary 2.2.4 *Let G be a graph and H a connected graph of order n . Then $G \square H \cong G \square H$ by a natural isomorphism if and only if there exists an $h \in \text{Aut}(H)$ such that*

$$\bigcap_{j=1}^n \pi^{-h(j)} \text{Aut}(G) \alpha^j \neq \emptyset.$$

Proof: For $h \in \text{Aut}(H)$, let $S_j(h) = \pi^{-h(j)} \text{Aut}(G) \alpha^j$, $j = 1, 2, \dots, n$, and consider a longest path $P : u_1, u_2, \dots, u_n$ in the connected graph H .

If $G \square H \cong G \square H$ by a natural isomorphism, then by Theorem 2.2.2 there exist an $h \in \text{Aut}(H)$ and $g_1, g_2, \dots, g_n \in \text{Aut}(G)$ such that $\pi^{h(j)-h(i)} g_i = g_j \alpha^{j-i}$ for every i, j such that $u_i u_j \in E(H)$. In other words, $\pi^{-h(i)} g_i \alpha^i = \pi^{-h(j)} g_j \alpha^j$ for any $u_i u_j \in E(H)$. Since $\pi^{-h(k)} g_k \alpha^k = \pi^{-h(k+1)} g_{k+1} \alpha^{k+1}$ for any $k = 1, 2, \dots, n-1$, there exists a permutation σ such that $\sigma = \pi^{-h(k)} g_k \alpha^k \in S_k(h)$ for every $k = 1, 2, \dots, n$.

Conversely, if $\sigma \in \bigcap_{j=1}^n S_j(h)$, then $\sigma = \pi^{-h(k)} g_k \alpha^k \in S_k(h)$ for some $h \in \text{Aut}(H)$ and $g_1, g_2, \dots, g_n \in \text{Aut}(G)$, $k = 1, 2, \dots, n$. For any edge $u_i u_j \in E(H)$, $\pi^{-h(i)} g_i \alpha^i = \sigma = \pi^{-h(j)} g_j \alpha^j$, so that $\pi^{h(j)-h(i)} g_i = g_j \alpha^{j-i}$. By Theorem 2.2.2, $G \square H \cong G \square H$ by a natural isomorphism. ■

The following corollary shows that a natural isomorphism between two generalized Cartesian products may directly imply a natural isomorphism between other generalized Cartesian products. Let $S_j(h) = \pi^{-h(j)}\text{Aut}(G)\alpha^j$, $j = 1, 2, \dots, n$, and $h \in \text{Aut}(H)$. Then $G \boxtimes H$ is said to be *isomorphic to $G \boxtimes H$ by a natural isomorphism with respect to h* if $\bigcap_{j=1}^n S_j(h) \neq \emptyset$.

Corollary 2.2.5 *Let G be a graph and H a connected graph. If $G \boxtimes H \cong G \boxtimes H$ by a natural isomorphism with respect to $h \in \text{Aut}(H)$, then $G \boxtimes F \cong G \boxtimes F$ by a natural isomorphism with respect to h for any connected graph F , with $V(F) = V(H)$ and $h \in \text{Aut}(F)$. ■*

Corollary 2.2.4 lends itself to a simple algorithm to determine whether or not two generalized Cartesian products $G \boxtimes H$ and $G \boxtimes H$ are isomorphic by a natural isomorphism. For $h \in \text{Aut}(H)$, determine the sets $S_j(h) = \pi^{-h(j)}\text{Aut}(G)\alpha^j$, $j = 1, 2, \dots, n$. If there exists a permutation $\sigma \in \bigcap_{j=1}^n S_j(h)$, then $G \boxtimes H \cong G \boxtimes H$ by a natural isomorphism with respect to h . By Theorem 2.2.2, the isomorphism is determined by h and $g_j = \pi^{h(j)}\sigma\alpha^{-j}$ as $\phi((v_i, u_j)) = (v_{g_j(i)}, u_{h(j)})$, $i = 1, 2, \dots, m$, $j = 1, 2, \dots, n$. To illustrate this, consider the products $C_5 \boxtimes K_2$ and $C_5 \boxtimes K_2$ shown in Figure 2.1, with $\alpha = (v_3, v_4, v_5)$ and $\pi = (v_1, v_2, v_3, v_5, v_4)$. For convenience, view these permutations as elements of S_5 acting on the subscripts of the vertices. Table 2.2 lists the elements in the sets $S_j(h)$ for h the identity automorphism $\mathbf{1}$ of H . In this case $\sigma = (1, 4, 3, 5, 2) \in \bigcap_{j=1}^n S_j(\mathbf{1})$, $g_1 = \mathbf{1}$ and $g_2 = (1, 2, 3, 4, 5)$, so that the natural isomorphism with respect to h is given by $\phi(v_{i,1}) = v_{i,1}$ and $\phi(v_{i,2}) = v_{i+1,2}$, $i = 1, 2, \dots, 5$, with addition on the subscripts performed modulo 5.

This section concludes with an interesting relationship between the generalized Cartesian product and the Cartesian product. As an example, consider the graph $G = 3K_2$ with partite sets $\{v_1, v_2, v_3\}$, $\{v_4, v_5, v_6\}$ and v_i adjacent to v_{i+3} , $i = 1, 2, 3$. Let $\pi = (v_1, v_2, v_3)(v_4, v_5, v_6)$ and $H = P_3$ with vertices u_1, u_2, u_3 . The generalized Cartesian product $G \boxtimes H$ is illustrated in Figure 2.6. Let $G' = \overline{K_3}$ and note that $G \cong G' \square K_2$. For convenience let $V(G') = \{v_1, v_2, v_3\}$. It is clear that $G \boxtimes H \cong (G' \boxtimes H) \square K_2$, where

$\text{Aut}(C_5)$	$S_1(\mathbf{1})$	$S_2(\mathbf{1})$
$\mathbf{1}$	$(1, 4, 3, 5, 2)$	$(1, 5, 3, 2, 4)$
$(1, 3)(4, 5)$	$(1, 2)(4, 5)$	$(2, 4, 5)$
$(1, 4)(2, 3)$	$(1, 5)(3, 4)$	$(1, 3, 2)$
$(1, 2, 3, 4, 5)$	$\mathbf{1}$	$(1, 4, 3, 5, 2)$
$(1, 5)(2, 4)$	$(1, 3)(2, 5)$	$(1, 2, 3, 5, 4)$
$(1, 3, 5, 2, 4)$	$(1, 2, 5, 3, 4)$	$(2, 3, 4)$
$(2, 5)(3, 4)$	$(1, 4)(2, 3)$	$(1, 5)(3, 4)$
$(1, 4, 2, 5, 3)$	$(1, 5, 4, 2, 3)$	$(1, 3)(4, 5)$
$(1, 5, 4, 3, 2)$	$(1, 3, 2, 4, 5)$	$(1, 2, 5)$
$(1, 2)(3, 5)$	$(2, 4)(3, 5)$	$(1, 4, 2, 5, 3)$

Table 2.2: The automorphism group of C_5 and the sets $S_j(\mathbf{1})$, $j = 1, 2$.

$\alpha = (v_1, v_2, v_3)$. For any Cartesian product G , the generalized Cartesian product $G \boxtimes H$ may be factorized in this manner for some permutation π . Let $A = \{a_1, a_2, \dots, a_m\}$ and $B = \{b_1, b_2, \dots, b_n\}$ be any two sets and α a permutation of A . A permutation π of $A \times B$ is called an *extension of α on $A \times B$* if $\pi((a_i, b_j)) = (\alpha(a_i), b_j)$, $i = 1, 2, \dots, m$, $j = 1, 2, \dots, n$.

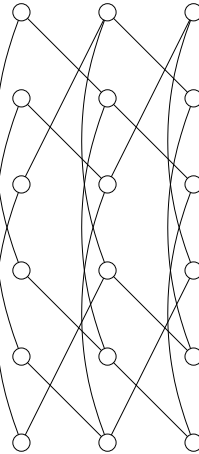


Figure 2.6: The graph $G \boxtimes H$, with $G = 3K_2$, $H = P_3$ and $\pi = (v_1, v_2, v_3)(v_4, v_5, v_6)$.

Proposition 2.2.1 *Let G , H and F be any graphs, α a permutation of $V(G)$, and let π be an extension of α on $V(G) \times V(F)$. Then $(G \square F) \boxtimes H \cong (G \boxtimes H) \square F$.*

Proof: Let $V(G) = \{v_1, v_2, \dots, v_m\}$, $V(H) = \{u_1, u_2, \dots, u_n\}$ and $V(F) = \{w_1, w_2, \dots, w_q\}$. Since π is an extension of α on $V(G) \times V(F)$, it follows that $\pi((v_i, w_j)) = (\alpha(v_i), w_j)$ for any $i = 1, 2, \dots, m$, $j = 1, 2, \dots, q$. Define a bijection $\phi : V((G \square F) \boxtimes H) \mapsto V((G \boxtimes H) \square F)$ by $\phi(((v_i, w_j), u_k)) = ((v_i, u_k), w_j)$, $i = 1, 2, \dots, m$, $j = 1, 2, \dots, q$, $k = 1, 2, \dots, n$. The bijection ϕ is shown to be an isomorphism by considering two cases for an edge $((v_i, w_j), u_k)((v_a, w_b), u_c)$ in $(G \square F) \boxtimes H$.

(i) Suppose $k = c$. Then

$$\begin{aligned}
& ((v_i, w_j), u_k)((v_a, w_b), u_c) \in E((G \square F) \boxtimes H) \\
& \Leftrightarrow (v_i, w_j)(v_a, w_b) \in E(G \square F) \\
& \Leftrightarrow w_j = w_b \text{ and } v_i v_a \in E(G), \text{ or } v_i = v_a \text{ and } w_j w_b \in E(F) \\
& \Leftrightarrow w_j = w_b \text{ and } (v_i, u_k)(v_a, u_c) \in E(G \boxtimes H), \\
& \qquad \qquad \qquad \text{or } (v_i, u_k) = (v_a, u_c) \text{ and } w_j w_b \in E(F) \\
& \Leftrightarrow ((v_i, u_k), w_j)((v_a, u_c), w_b) \in E((G \boxtimes H) \square F) \\
& \Leftrightarrow \phi(((v_i, w_j), u_k))\phi(((v_a, w_b), u_c)) \in E((G \boxtimes H) \square F).
\end{aligned}$$

(ii) Suppose $k \neq c$. Then

$$\begin{aligned}
& ((v_i, w_j), u_k)((v_a, w_b), u_c) \in E((G \square F) \boxtimes H) \\
& \Leftrightarrow u_k u_c \in E(H) \text{ and } (v_a, w_b) = \pi^{c-k}((v_i, w_j)) \\
& \Leftrightarrow u_k u_c \in E(H) \text{ and } (v_a, w_b) = (\alpha^{c-k}(v_i), w_j) \\
& \Leftrightarrow u_k u_c \in E(H) \text{ and } v_a = \alpha^{c-k}(v_i) \text{ and } w_b = w_j \\
& \Leftrightarrow (v_i, u_k)(v_a, u_c) \in E(G \boxtimes H) \text{ and } w_b = w_j \\
& \Leftrightarrow ((v_i, u_k), w_j)((v_a, u_c), w_b) \in E((G \boxtimes H) \square F) \\
& \Leftrightarrow \phi(((v_i, w_j), u_k))\phi(((v_a, w_b), u_c)) \in E((G \boxtimes H) \square F).
\end{aligned}$$

It follows that ϕ is an isomorphism. ■

The above-mentioned generalized Cartesian products suggest two possible generalizations of the hypercube Q_n . However, both generalizations lead to graphs that are isomorphic to Q_n . Recall that the 2-cube Q_2 is the Cartesian product $K_2 \square K_2$, while $Q_{n+1} = Q_n \square K_2$ (or $K_2 \square Q_n$), $n \geq 2$. For a permutation π of $V(K_2)$, a *generalized n -cube* $Q_{n,\pi}$ may be defined by $Q_{2,\pi} = K_2 \boxtimes K_2$ and $Q_{n+1,\pi} = K_2 \boxtimes Q_{n,\pi}$, $n \geq 2$. However, since any permutation π of $V(K_2)$ is an automorphism of K_2 , $K_2 \boxtimes H \cong K_2 \square H$ for any graph H , so that $Q_n \cong Q_{n,\pi}$ for any $n \geq 2$ and permutation π .

Alternatively, let $Q_{1,\pi} = K_2$, $Q_{2,\pi} = K_2 \boxtimes K_2$, and define $Q_{n+1,\pi} = Q_{n,\alpha} \boxtimes K_2$, where π is an extension of α on $V(Q_{n,\alpha})$, $n \geq 2$. However, note that for any α and extension π of α on $V(Q_{2,\alpha})$,

$$\begin{aligned}
 Q_3 &= Q_2 \square K_2 \\
 &= (K_2 \square K_2) \square K_2 \\
 &\cong (K_2 \boxtimes K_2) \square K_2 \quad (\text{since any } \alpha \in \text{Aut}(K_2)) \\
 &\cong (K_2 \square K_2) \boxtimes K_2 \quad (\text{by Proposition 2.2.1}) \\
 &\cong (K_2 \boxtimes K_2) \boxtimes K_2 \quad (\text{since } \alpha \in \text{Aut}(K_2)) \\
 &= Q_{3,\pi}.
 \end{aligned}$$

Inductively, it follows by a similar argument that $Q_{n,\pi} \cong Q_n$, $n \geq 2$, for any permutation π as defined above.

2.3 The Diameter

An investigation into the diameter of the generalized Cartesian product may prove useful in highlighting the distinctions between this product and the Cartesian product. Throughout this section let G and H be connected graphs with vertex sets $\{v_1, v_2, \dots, v_m\}$ and $\{u_1, u_2, \dots, u_n\}$ respectively. For any graphs G and H , $\text{diam}(G \square H) = \text{diam}(G) + \text{diam}(H)$, and $\text{diam}(G \square H)$ is an upper bound for $\text{diam}(G \boxtimes H)$ for any permutation π of $V(G)$. Equality is obtained for any $\pi \in \text{Aut}(G)$.

Proposition 2.3.1 *For any connected graphs G and H , $\text{diam}(G \boxtimes H) \leq \text{diam}(G \square H)$ for any permutation π .*

Proof: Let π be any permutation of $V(G)$ and $v_{i,j}, v_{k,l}$ be vertices of $G \boxtimes H$. If $j = l$, then $d_{G \boxtimes H}(v_{i,j}, v_{k,l}) \leq \text{diam}(G)$, since the vertices are in the same G -layer. Otherwise let $v_q = \pi^{l-j}(v_i)$. Then $v_{i,j}$ and $v_{q,l}$ are in the same H -layer, so that

$$\begin{aligned} d_{G \boxtimes H}(v_{i,j}, v_{k,l}) &\leq d_H(u_j, u_l) + d_G(v_q, v_k) \\ &\leq \text{diam}(H) + \text{diam}(G) \\ &= \text{diam}(G \square H), \end{aligned}$$

yielding the desired inequality. ■

Let $d = \text{diam}(G)$ and v be a peripheral vertex of G , i.e. a vertex that lies on the end of some diametrical path of G . Let $X_0 = \{v\}$ and $X_i = \{x : d(v, x) = i\}$, $i = 1, 2, \dots, d$. Consider a permutation π of $V(G)$ such that $\pi(X_i) = X_i$ for each $i = 0, 1, \dots, d$. Without loss of generality, suppose $v_1 = v$ and $v_m \in X_d$. Let $u_j, u_l \in V(H)$ such that $d_H(u_j, u_l) = \text{diam}(H)$. If $d_{G \boxtimes H}(v_{1,j}, v_{m,l}) < \text{diam}(G) + \text{diam}(H)$, then by the choice of π , there exists either (i) a v_1 - v_m path in G of length less than $\text{diam}(G)$, or (ii) a u_j - u_l path in H of length less than

$\text{diam}(H)$. So $d_{G\boxtimes H}(v_{1,j}, v_{m,l}) = \text{diam}(G) + \text{diam}(H) = \text{diam}(G \square H)$, and it follows that $\text{diam}(G \boxtimes H) = \text{diam}(G \square H)$.

For the Cartesian product $G \square H$, $d(v_{i,j}, v_{k,l}) = \text{diam}(G \square H)$ if and only if $v_{i,j}$ and $v_{k,l}$ are peripheral vertices such that $d_G(v_i, v_k) = \text{diam}(G)$ and $d_H(u_j, u_l) = \text{diam}(H)$. Accordingly, call a pair of vertices $v_{i,j}, v_{k,l} \in V(G \boxtimes H)$ a *peripheral pair* if

- $d_H(u_j, u_l) = \text{diam}(H)$,
- $d_G(\pi^{l-j}(v_i), v_k) = \text{diam}(G)$, and
- $d_G(v_i, \pi^{j-l}(v_k)) = \text{diam}(G)$.

Suppose $G \boxtimes H$ does not have a peripheral pair of vertices. Then there exists either (i) a $\pi^{l-j}(v_i)-v_k$ path in G of length less than $\text{diam}(G)$, (ii) a $v_i-\pi^{j-l}(v_k)$ path in G of length less than $\text{diam}(G)$, or (iii) a u_j-u_l path in H of length less than $\text{diam}(H)$. In each case $d_{G\boxtimes H}(v_{i,j}, v_{k,l}) < \text{diam}(G) + \text{diam}(H) = \text{diam}(G \square H)$ for each $v_{i,j}, v_{k,l} \in V(G \boxtimes H)$, and it follows that $\text{diam}(G \boxtimes H) < \text{diam}(G \square H)$. This motivates the following necessary condition for the equality $\text{diam}(G \boxtimes H) = \text{diam}(G \square H)$.

Proposition 2.3.2 *Let G and H be two connected graphs and π a permutation of $V(G)$. If $\text{diam}(G \boxtimes H) = \text{diam}(G \square H)$, then there exists a peripheral pair of vertices in $G \boxtimes H$. ■*

To establish an inequality between the respective diameters, only the behaviour of the permutation π on the peripheral vertices of G and H respectively, need to be examined. If a peripheral pair does not exist, then $\text{diam}(G \boxtimes H) < \text{diam}(G \square H)$. To verify that the necessary condition stated in Proposition 2.3.2 is not sufficient, consider the generalized Cartesian product $P_m \boxtimes P_n$, $\pi = (v_1, v_2)$, illustrated in Figure 2.7 for the case $n = 3$ and $m = 3$. The vertices $v_{1,1}$ and $v_{3,3}$ form a peripheral pair, even though $\text{diam}(P_3 \boxtimes P_3) = 3 < \text{diam}(P_3 \square P_3)$. In general, the vertices $v_{1,1}$ and $v_{m,n}$ form a peripheral pair of $P_m \boxtimes P_n$ if n is odd. It is easy to verify that $\text{diam}(P_m \boxtimes P_n) = m + n - 1 < \text{diam}(P_m \square P_n)$ in this case (with $\pi = (v_1, v_2)$).

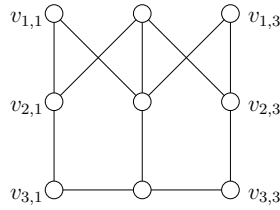


Figure 2.7: The graph $P_3 \boxtimes P_3$, $\pi = (v_1, v_2)$.

Let $d = \text{diam}(G)$ and v be a peripheral vertex of G . Again, let $X_0 = \{v\}$ and $X_i = \{x : d(v, x) = i\}$, $i = 1, 2, \dots, d$, and consider a permutation π of $V(G)$ such that $\pi(X_i) = X_i$ for each $i = 0, 1, \dots, d$. From the proof of Proposition 2.3.1 it follows that $\text{diam}(G \boxtimes H) = \text{diam}(G \square H)$. However, this condition is not necessary for equality to hold in general. As an example, consider the tree T shown in Figure 2.8. This graph has a unique pair of peripheral vertices u and v . Let π be any permutation with the above mentioned property on $T - \{x, y\}$, and let $\pi(x) = y$ and $\pi(y) = x$. Then it is easy to verify that $\text{diam}(T \boxtimes H) = \text{diam}(T \square H)$ for any graph H .

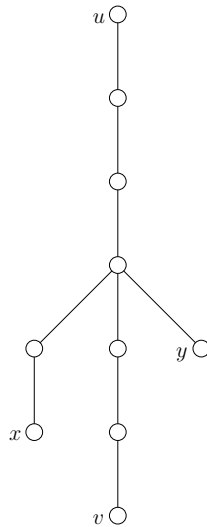


Figure 2.8: The tree T .

A sufficient condition on π such that $\text{diam}(G \boxtimes H) = \text{diam}(G \square H)$ is provided next. A permutation π is called *diameter preserving* if there exists a peripheral vertex w in G , such

that for every $x \in V(G)$, $d(\pi^{k-j}(x), w) \geq d(x, w)$ for every edge $u_j u_k \in E(H)$. Suppose that in $G \boxtimes H$, $d(v_{i,j}, v_{k,l}) = \text{diam}(G \boxtimes H) = \text{diam}(G \square H)$. The requirement that π be diameter preserving ensures that any $v_{i,j} - v_{k,l}$ path contains at least $\text{diam}(G)$ edges from G -layers in $G \boxtimes H$, and at least $\text{diam}(H)$ edges from H -layers. For convenience let $d_G = \text{diam}(G)$ and $d_H = \text{diam}(H)$.

Proposition 2.3.3 *Let G and H be connected graphs and π a permutation of $V(G)$. If π is diameter preserving then $\text{diam}(G \boxtimes H) = \text{diam}(G \square H)$.*

Proof: Suppose π is a permutation of $V(G)$ for which $\text{diam}(G \boxtimes H) < \text{diam}(G \square H)$. Let v_i and v_k be any peripheral vertices of G such that $d(v_i, v_k) = d_G$. Consider vertices $v_{i,j} = (v_i, u_j)$ and $v_{k,l} = (v_k, u_l)$ in $G \boxtimes H$ such that $d(u_j, u_l) = d_H$, and let W denote a shortest $v_{i,j} - v_{k,l}$ path in $G \boxtimes H$. Since $\text{diam}(G \boxtimes H) < \text{diam}(G \square H)$, W contains fewer than d_G edges from G -layers in $G \boxtimes H$. (It necessarily contains at least d_H edges from H -layers.) Let W_H be the path in H that corresponds to W , obtained from $p_H(E(W))$. It follows that for some edge $u_q u_r$ in H and vertex x in G , $(x, u_q)(\pi^{r-q}(x), u_r) \in E(W)$ and $d(\pi^{r-q}(x), v_k) < d(x, v_k)$. Hence π is not diameter preserving. ■

To confirm that the above-mentioned condition on π is not necessary, consider the generalized Cartesian product $G \boxtimes H$, with $G = P_3$, $H = C_5$, $\pi = (v_1, v_2)$ and the labellings as shown in Figure 2.9. The vertices v_1 and v_3 are the only peripheral vertices in G . Considering the vertex v_1 , $d(\pi(v_1), v_3) < d(v_1, v_3)$ for the edge $u_1 u_2$ in H . So π is not diameter preserving, but it can be verified easily that $\text{diam}(P_3 \boxtimes C_5) = 4 = \text{diam}(P_3 \square C_5)$. For example, $d(v_{1,1}, v_{3,5}) = 4$ (these vertices are the dark vertices in Figure 2.9).

In an attempt to gain insight into the generalized Cartesian products $G \boxtimes H$ for which $\text{diam}(G \boxtimes H) = \text{diam}(G \square H)$, define the following edge labelling f for a $v_{i,j} - v_{k,l}$ path W in $G \boxtimes H$. Let $d_G = d(v_i, v_k) = \text{diam}(G)$ and $d_H = d(u_j, u_l) = \text{diam}(H)$. For any edge

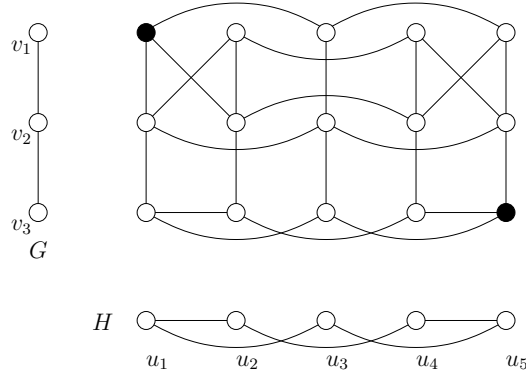


Figure 2.9: The generalized Cartesian product $G \square H$, with $G = P_3$, $H = C_5$ and $\pi = (v_1, v_2)$.

$e = v_{a,b}v_{q,r}$ in W ,

$$f(v_{a,b}v_{q,r}) = \begin{cases} d(v_q, v_k) - d(v_a, v_k) + 1 & \text{if } u_b \neq u_r \text{ and } d(u_r, u_l) \geq d(u_b, u_l) \\ d(v_q, v_k) - d(v_a, v_k) & \text{if } u_b \neq u_r \text{ and } d(u_r, u_l) < d(u_b, u_l) \\ d(v_q, v_k) - d(v_a, v_k) & \text{if } u_b = u_r \text{ and } d(v_q, v_k) > d(v_a, v_k) \\ d(v_q, v_k) - d(v_a, v_k) + 1 & \text{if } u_b = u_r \text{ and } d(v_q, v_k) \leq d(v_a, v_k). \end{cases}$$

Informally,

- $f(e) = 1$ if traversing the edge $v_a v_q$ in a G -layer causes the distance “ v_a to v_k ” to increase to “ v_q to v_k ” (necessarily by one), or remain the same;
- $f(e) = 0$ if traversing the edge $v_a v_q$ in a G -layer causes the distance “ v_a to v_k ” to decrease (by one) to “ v_q to v_k ”;
- $f(e) = 0$ if traversing the edge $u_b u_r$ in an H -layer causes the distance “ u_b to u_l ” to decrease (by one) to “ u_r to u_l ”, while not changing the distance in a G -layer to v_k ;
- $f(e) = s + 1$ if traversing the edge $u_b u_r$ in an H -layer causes the distance “ u_b to u_l ” to increase (by one) to “ u_r to u_l ” or remain the same, while (in the G -layers) changing the distance “ v_a to v_k ” by s (either increasing or decreasing) to “ v_q to v_k ”.

If the path W has an edge with a negative label (necessarily in an H -layer), it means that fewer than d_G G -layer edges might potentially be used to reach the vertex $v_{k,l}$. However, the walk in H corresponding to W might be longer than d_H , thereby negating the apparent gain. Define the weight of a path W as the sum of the edge labels along the path. Clearly, if $\text{diam}(G \boxtimes H) < d_G + d_H$, then a shortest path between two peripheral vertices in $G \boxtimes H$ has negative weight for any such pair of vertices. Conversely, if $\text{diam}(G \boxtimes H) = d_G + d_H$, then there exists a pair of peripheral vertices, distance $\text{diam}(G \boxtimes H)$ apart, such that any shortest path between them has a weight of 0. (Since $\text{diam}(G \boxtimes H) \leq \text{diam}(G \square H)$, there necessarily exists a path with weight at most 0.) To illustrate the above discussion, Figure 2.10 shows the labelling of a $v_{1,1}v_{3,5}$ path in $P_3 \boxtimes C_5$, with $\pi = (v_1, v_2)$ and the vertex labelling of $V(C_5)$ as shown. This path is indicated by thick edges. It is clear that, although traversing the edge $v_{1,1}v_{2,2}$ seemingly avoids the need to traverse three edges in P_3 -layers (the G -layers), the corresponding path in $H = C_5$ is longer than the diameter $d_H = 2$.

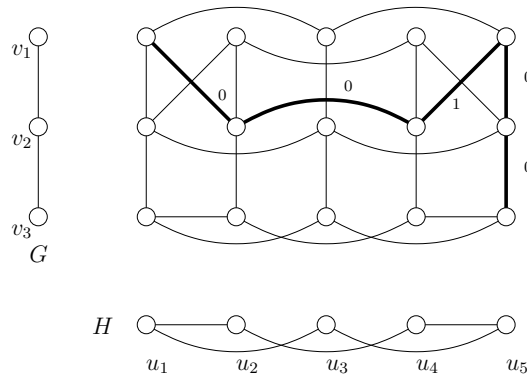


Figure 2.10: The generalized Cartesian product $P_3 \boxtimes C_5$, $\pi = (v_1, v_2)$.

The generalized Cartesian product $P_4 \boxtimes C_5$ is shown in Figure 2.11, with $\pi = (v_1, v_3)$ and vertex labelling on $H = C_5$ as shown. The path shown by thick edges has a weight of -1 , and it is easily verified that $\text{diam}(P_4 \boxtimes C_5) < \text{diam}(P_4 \square C_5)$.

Lastly, it should be noted that there exist graphs G , H and permutations π for which $\text{diam}(G \boxtimes H) = \text{diam}(G \square H)$, but $\gamma(G \boxtimes H) \neq \gamma(G \square H)$. As an example, let $n \geq 3$ and

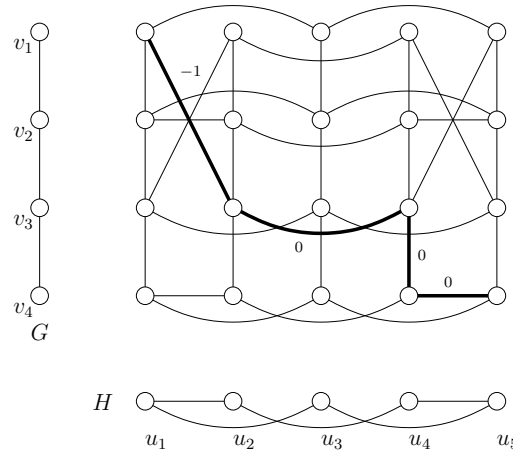


Figure 2.11: The generalized Cartesian product $P_4 \square C_5$, $\pi = (v_1, v_3)$.

G_n consist of $K_{1,n}$ and P_4 , with a support vertex of P_4 joined to the support vertex of $K_{1,n}$. Figure 2.12 shows the resulting graph G_3 for the case $n = 3$. Partition the vertex set into sets X_0, X_1, X_2, X_3, X_4 as indicated, let $\pi(X_i) = X_i$ on $G_3 - \{x, y\}$, $\pi(x) = y$ and $\pi(y) = x$. Then π is diameter preserving on the peripheral vertex $w \in X_0$ of G , so that $\text{diam}(G \square H) = \text{diam}(G \square H)$ for any H . For $H = P_3$, it is easy to verify that $\gamma(G \square P_3) = 5$, while $\gamma(G \square P_3) = 6$.

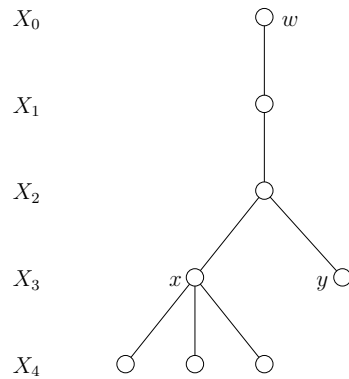


Figure 2.12: The graph G_3 .

2.4 A Vizing Inequality

The study of domination of the generalized Cartesian product is initiated by a brief investigation into a so-called Vizing inequality for this graph product. As mentioned in Section 1.2.1, Vizing [70] posed the question of whether the domination number of the Cartesian product of any two graphs is at least as large as the product of the respective domination numbers. It may be interesting to investigate such an inequality for the generalized Cartesian product of two graphs.

Conjecture 2.4.1 [71] *For any graphs G and H , $\gamma(G \square H) \geq \gamma(G)\gamma(H)$.*

A graph G is said to satisfy Vizing's conjecture if $\gamma(G \square H) \geq \gamma(G)\gamma(H)$ for any graph H . A graph G is said to *satisfy [not satisfy] a Vizing inequality with respect to a graph H for a permutation π of $V(G)$* if $\gamma(G \boxtimes H) \geq \gamma(G)\gamma(H)$ [$\gamma(G \boxtimes H) < \gamma(G)\gamma(H)$]. Although many researchers believe Vizing's conjecture to be true, a Vizing inequality does not hold for all graphs G , H and permutations π in the case of the generalized Cartesian product. Examples are provided to illustrate the different cases.

The complete graph K_m is known to satisfy Vizing's conjecture (since it is clearly decomposable, as defined in Section 1.2.1). For any permutation π of $V(K_m)$, $\pi \in \text{Aut}(K_m)$, and so $K_m \boxtimes H \cong K_m \square H$ by Corollary 2.2.3. The complete graph K_m therefore satisfies a Vizing inequality with respect to any H for any π . Furthermore, it is easy to verify that $\gamma(K_m \boxtimes K_n) = \min\{m, n\}$ for any $m, n \geq 2$ and permutation π .

As mentioned in Section 1.2.1, Fink, Jacobson, Kinch and Roberts [23] showed that the 4-cycle and coronas are the only connected graphs with domination number equal to half their order, and that for the Cartesian product of such graphs of order at least 4, equality is attained in Vizing's conjecture. When considering a generalized Cartesian product of such graphs, it is shown that sometimes a Vizing inequality does not hold for some permutations.

For the generalized Cartesian product $G \boxtimes H$ with H a cycle, consider a canonical labelling of $V(H) = \{u_1, u_2, \dots, u_n\}$ throughout. In the case where G is the corona of an order m graph F , i.e. $G = \text{cor}(F)$, denote the vertices of $\text{cor}(F)$ by $\{v_i, w_i : i = 1, 2, \dots, m\}$, with $\langle \{v_i : i = 1, 2, \dots, m\} \rangle \cong F$ and $v_i w_i \in E(\text{cor}(F))$ for each $i = 1, 2, \dots, m$. The following proposition provides a lower bound for the domination number of $\text{cor}(G) \boxtimes H$.

Proposition 2.4.1 *Let G and H be graphs of order m and n respectively. Then $\gamma(\text{cor}(G) \boxtimes H) \geq \lceil \frac{mn}{1+\Delta(H)} \rceil$ for any permutation π of $V(\text{cor}(G))$.*

Proof: Let $B = \{(w_i, u_j) : i = 1, 2, \dots, m, j = 1, 2, \dots, n\}$. Then $|B| = mn$ and, since any vertex in $\text{cor}(G) \boxtimes H$ dominates at most $1 + \Delta(H)$ vertices in B , any dominating set of $\text{cor}(G) \boxtimes H$ contains at least $\lceil \frac{mn}{1+\Delta(H)} \rceil$ vertices, for any permutation π of $V(\text{cor}(G))$. ■

In the case of the generalized Cartesian product $\text{cor}(K_m) \boxtimes C_4$, the lower bound on the domination number is $\lceil \frac{4m}{3} \rceil$. It is shown that this bound is attained for some permutation π . Since $\lceil \frac{4m}{3} \rceil < 2m$ if $m \geq 2$, it follows that there exists a π such that a Vizing inequality does not hold between these two graphs.

Proposition 2.4.2 *For any $m \geq 3$, there exists a permutation π of $V(\text{cor}(K_m))$ such that $\gamma(\text{cor}(K_m) \boxtimes C_4) = \lceil \frac{4m}{3} \rceil$.*

Proof: From Proposition 2.4.1, $\gamma(\text{cor}(K_m) \boxtimes C_4) \geq \lceil \frac{4m}{3} \rceil$. Choose a permutation π and construct a dominating set D of $\text{cor}(K_m) \boxtimes C_4$ of cardinality $\lceil \frac{4m}{3} \rceil$ as follows.

Let $q = \lfloor \frac{m}{3} \rfloor$, $Y = \{w_{3q+1}, w_{3q+2}\} \times V(C_4)$ (note that Y may be empty) and first define the permutation

$$\alpha = \prod_{i=1}^q (w_{3i-2}, v_{3i}, w_{3i-1}, v_{3i-1})$$

and $D' = \{(v_{3i}, u_j) : i = 1, 2, \dots, q, j = 1, 2, 3, 4\}$. The permutation π is a product of disjoint cycles $\alpha\beta$, where β depends on the congruence class of m modulo 3 and will be

defined later as either the identity or a transposition. Then

- (i) $(v_3, u_j) \succ \{(v_i, u_j)\}$ for each $i = 1, 2, \dots, m, j = 1, 2, 3, 4$, since $\langle \{v_i : i = 1, 2, \dots, m\} \rangle$ is complete;
- (ii) $(v_{3i}, u_j) \succ (w_{3i}, u_j)$ for each $i = 1, 2, \dots, q, j = 1, 2, 3, 4$, since $v_{3i}w_{3i} \in E(\text{cor}(K_m))$.

For each $i \in \{1, 2, \dots, q\}$, α ensures that each of the following sets induces a C_4 -layer in $\text{cor}(K_m) \boxtimes C_4$:

$$\begin{aligned} & \{\underline{(v_{3i}, u_1)}, (w_{3i-1}, u_2), (v_{3i-1}, u_3), (w_{3i-2}, u_4)\}; \\ & \{(w_{3i-1}, u_1), (v_{3i-1}, u_2), (w_{3i-2}, u_3), \underline{(v_{3i}, u_4)}\}; \\ & \{(v_{3i-1}, u_1), (w_{3i-2}, u_2), \underline{(v_{3i}, u_3)}, (w_{3i-1}, u_4)\}; \\ & \{(w_{3i-2}, u_1), \underline{(v_{3i}, u_2)}, (w_{3i-1}, u_3), (v_{3i-1}, u_4)\}. \end{aligned}$$

The cycle $(w_{3i-2}, v_{3i}, w_{3i-1}, v_{3i-1})$ in α is shown in Figure 2.13 to illustrate this. For the sake of convenience only the first label of each vertex is shown, the vertices in D' are shown as dark vertices, and edges between the first and last $\text{cor}(K_m)$ -layer are not shown. Since each set contains a vertex $(v_{3i}, u_k) \in D'$, and each vertex (w_j, u_k) for $3i - 2 \leq j \leq 3i - 1$ is contained in one of the sets,

- (iii) $D' \succ \{(w_{3i-2}, u_k), (w_{3i-1}, u_k) : 1 \leq i \leq q, 1 \leq k \leq 4\}$.

Therefore, by (i) – (iii), D' is a dominating set of $\text{cor}(K_m) \boxtimes C_4 - Y$. Moreover, $|D'| = 4q$. Three cases are distinguished based on the congruence class of m modulo 3.

Case 1: $m \equiv 0 \pmod{3}$. Define the permutation π of $V(\text{cor}(K_m))$ by $\pi = \alpha$ and the set $D = D'$. Then $|D'| = \frac{4m}{3}$.

Case 2: $m \equiv 1 \pmod{3}$. Define the permutation π of $V(\text{cor}(K_m))$ by $\pi = \alpha$ and the set $D = D' \cup \{(w_m, u_1), (w_m, u_3)\}$. Note that $Y = \{(w_m, u_j) : j = 1, 2, 3, 4\}$. Then

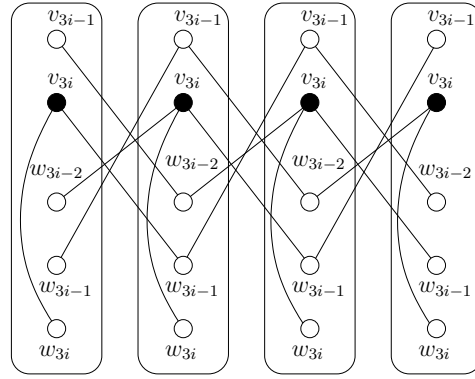


Figure 2.13: A domination strategy of $\text{cor}(K_m) \square C_4$. Edges between the first and last $\text{cor}(K_m)$ -layer are not shown.

$|D| = 4q + 2 = \lceil \frac{4m}{3} \rceil$ and $\{(w_m, u_1), (w_m, u_3)\} \succ Y$, since $\pi(w_m) = w_m$ implies that $\langle \{(w_m, u_j) : j = 1, 2, 3, 4\} \rangle \cong C_4$.

Case 3: $m \equiv 2 \pmod{3}$. Define the permutation π of $V(\text{cor}(K_m))$ by $\pi = \alpha(v_m, w_{m-1})$ and the set $D = D' \cup \{(v_m, u_2), (v_m, u_3), (w_m, u_4)\}$. Note that $Y = \{(w_{m-1}, u_j), (w_m, u_j) : j = 1, 2, 3, 4\}$. Then $|D| = 4q + 3 = \lceil \frac{4m}{3} \rceil$ and $\{(v_m, u_2), (v_m, u_3), (w_m, u_4)\} \succ Y$, as illustrated in Figure 2.14. (For the sake of convenience only the first label of each vertex is shown, and the vertices in D are shown as dark vertices.)

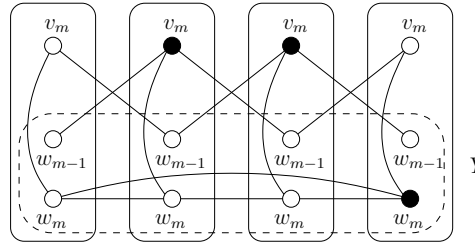


Figure 2.14: A domination strategy of the set Y in the case $m \equiv 2 \pmod{3}$. Not all vertices or edges are shown.

In each of these cases the set D is a dominating set of $\text{cor}(K_m) \square C_4$ of cardinality $\lceil \frac{4m}{3} \rceil$. ■

Also consider the generalized Cartesian product $\text{cor}(K_m) \square C_n$ and note that a lower bound of $\lceil \frac{mn}{3} \rceil$ on the domination number of this graph is given by Proposition 2.4.1. For the case

$n \equiv 0 \pmod{3}$, it follows that $\gamma(\text{cor}(K_m) \boxtimes C_n) \geq \lceil \frac{mn}{3} \rceil = m \lceil \frac{n}{3} \rceil = \gamma(\text{cor}(K_m))\gamma(C_n)$, so that a Vizing inequality holds for any permutation π of $V(\text{cor}(K_m))$. For $n \not\equiv 0 \pmod{3}$, a Vizing inequality does not always hold.

Proposition 2.4.3 *Let $m, n \geq 3$ and $q \geq 3$ be a factor of n . If $m \geq \max\{3, q - 2\}$, then there exists a permutation π of $V(\text{cor}(K_m))$ such that $\gamma(\text{cor}(K_m) \boxtimes C_n) \leq \gamma(\text{cor}(K_n))\gamma(C_n)$. Moreover, this inequality is strict if $n \not\equiv 0 \pmod{3}$.*

Proof: Define a permutation π and construct a dominating set D of $\text{cor}(K_m) \boxtimes C_n$ of cardinality at most $m \lceil \frac{n}{3} \rceil$ as follows. In the special case where $q = 3$, let $\pi = (w_2, v_1, w_3)$. Otherwise let $\pi = (w_2, v_1, w_3, v_2, v_3, \dots, v_{q-2})$. By the choice of q being a factor of n , any vertex (w_i, u_j) is adjacent to some (v_1, u_k) in a C_n -layer of $\text{cor}(K_n) \boxtimes C_n$, $i = 2, 3$. For $i = 4, 5, \dots, m$, each of the sets $S_i = \{(w_i, u_j) : j = 1, 2, \dots, n\}$ induces an n -cycle, since $\pi(w_i) = w_i$. Let D_i be a dominating set of the n -cycle induced by S_i . Consider the set $D = \{(v_1, u_j) : j = 1, 2, \dots, n\} \cup D_4 \cup \dots \cup D_m$, as shown in Figure 2.15. Then

- (i) $(v_1, u_j) \succ \{(v_i, u_j)\}$ for each $i = 1, 2, \dots, m$, $j = 1, 2, \dots, n$, since $\langle \{v_i : i = 1, 2, \dots, m\} \rangle$ is complete;
- (ii) $(v_1, u_j) \succ (w_1, u_j)$ for each $j = 1, 2, \dots, n$, since $v_1 w_1 \in E(\text{cor}(K_m))$;
- (iii) for each $i \in \{2, 3\}$, π ensures that each (w_i, u_j) is adjacent to some (v_1, u_k) in a C_n -layer of $\text{cor}(K_n) \boxtimes C_n$, since q is a factor of n ;
- (iv) for each $i \in \{4, 5, \dots, m\}$, $D_i \succ \{(w_i, u_j)\}$ for each $j = 1, 2, \dots, n$, since $\pi(w_i) = w_i$ implies that $\langle \{(w_m, u_j) : j = 1, 2, \dots, n\} \rangle \cong C_n$.

The permutation π is shown in Figure 2.15 to illustrate (iii). For the sake of convenience only the first label of each vertex is shown, and the vertices in D are shown as dark vertices.

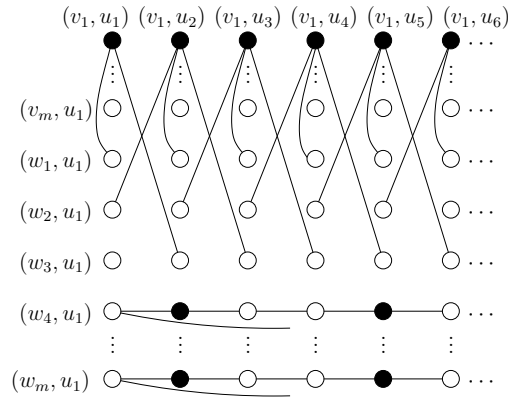


Figure 2.15: A domination strategy of $\text{cor}(K_m) \square C_n$. Not all vertices or edges are shown.

It follows from (i) – (iv) that D is a dominating set of $\text{cor}(K_m) \square C_n$, so that

$$\begin{aligned}
 \gamma(\text{cor}(K_m) \square C_n) &\leq |D| \\
 &= n + (m - 3) \left\lceil \frac{n}{3} \right\rceil \\
 &\leq 3 \left\lceil \frac{n}{3} \right\rceil + (m - 3) \left\lceil \frac{n}{3} \right\rceil \\
 &= m \left\lceil \frac{n}{3} \right\rceil.
 \end{aligned}$$

If $n \equiv 0 \pmod{3}$, then $\gamma(\text{cor}(K_m) \square C_n) \geq \gamma(\text{cor}(K_m))\gamma(C_n)$ by Proposition 2.4.1, so that D is in fact a minimum dominating set of $\text{cor}(K_m) \square C_n$. Otherwise, if $n \not\equiv 0 \pmod{3}$, then the inequality is strict, since $n < 3\lceil \frac{n}{3} \rceil$ in this case. ■

The argument in Proposition 2.4.3 relies on the first graph in the generalized Cartesian product being the corona of a complete graph. There exist other graphs G such that $\gamma(\text{cor}(G) \square H) < \gamma(\text{cor}(G))\gamma(H)$ for some H and permutation π , thereby not satisfying a Vizing inequality, as shown next. The proof follows a similar argument to that used in Proposition 2.4.2.

Theorem 2.4.1 *Let G be a graph of order $m \geq 7$ such that $\gamma(G) \leq \lfloor \frac{m}{3} \rfloor$. Then there exist a graph H and a permutation π of $V(\text{cor}(G))$ such that $\gamma(\text{cor}(G) \square H) < \gamma(\text{cor}(G))\gamma(H)$.*

Proof: Let $q = \lfloor \frac{m}{3} \rfloor$ and $Z \subseteq V(G)$ be a set of cardinality q that contains a γ -set of G . Also, let $H = C_n$ with $n \equiv 0 \pmod{4}$ and $n \not\equiv 0 \pmod{3}$. From Proposition 2.4.1 $\gamma(\text{cor}(G) \boxtimes C_n) \geq \lceil \frac{mn}{3} \rceil$. Define a permutation π and construct a dominating set D of $\text{cor}(G) \boxtimes C_n$ of cardinality at most $\lceil \frac{mn}{3} \rceil + 1$ as explained below. Since $\lceil \frac{mn}{3} \rceil + 1 < m \lceil \frac{n}{3} \rceil$ if $m \geq 7$, the result will follow. Recall the notation $V(\text{cor}(G)) = \{v_i, w_i : i = 1, 2, \dots, m\}$, with $\langle \{v_i : i = 1, 2, \dots, m\} \rangle \cong G$ and $v_i w_i \in E(\text{cor}(G))$ for each $i = 1, 2, \dots, m$. Without loss of generality, say $Z = \{v_{3i} : i = 1, 2, \dots, q\}$. Let $Y = \{w_{3q+1}, w_{3q+2}\} \times V(C_n)$ (note that Y may be empty) and define

$$\pi = \prod_{i=1}^q (w_{3i-2}, v_{3i}, w_{3i-1}, v_{3i-1})$$

and $D' = \{(v_{3i}, u_j) : i = 1, 2, \dots, q, j = 1, 2, \dots, n\}$. Then

- (i) $p^{-1}(Z) \succ \{(v_i, u_j)\}$ for each $i = 1, 2, \dots, m, j = 1, 2, \dots, n$, since Z contains a γ -set of G ;
- (ii) $(v_{3i}, u_j) \succ (w_{3i}, u_j)$ for each $i = 1, 2, \dots, q, j = 1, 2, \dots, n$, since $v_{3i} w_{3i} \in E(\text{cor}(G))$;
- (iii) for each $i \in \{1, 2, \dots, q\}$, π ensures that each (w_{3i-2}, u_j) is adjacent to (v_{3i}, u_{j+1}) in a C_n -layer of $\text{cor}(G) \boxtimes C_n$ (addition on the subscript of u performed modulo n), since $n \equiv 0 \pmod{4}$;
- (iv) for each $i \in \{1, 2, \dots, q\}$, π ensures that each (w_{3i-1}, u_j) is adjacent to (v_{3i}, u_{j-1}) in a C_n -layer of $\text{cor}(G) \boxtimes C_n$ (addition on the subscript of u performed modulo n), since $n \equiv 0 \pmod{4}$.

The cycle $(w_{3i-2}, v_{3i}, w_{3i-1}, v_{3i-1})$ in π is shown in Figure 2.16 to illustrate (iii) and (iv). For the sake of convenience only the first label of each vertex is shown, and the vertices in D' are shown as dark vertices. By (i) – (iv), D' is a dominating set of $\text{cor}(G) \boxtimes C_n - Y$.

Moreover, $|D'| = qn$. Distinguish between three cases based on the congruence class of m modulo 3.

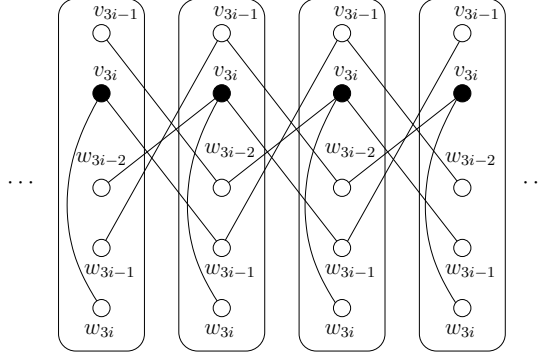


Figure 2.16: A domination strategy of $\text{cor}(G) \square C_n$. Not all vertices or edges are shown.

Case 1: $m \equiv 0 \pmod{3}$. Define the set $D = D'$. Then D is a dominating set of $\text{cor}(G) \square C_n$ of cardinality $|D| = \frac{mn}{3} = \lceil \frac{mn}{3} \rceil$.

Case 2: $m \equiv 1 \pmod{3}$. Note that $S = \{(w_m, u_j) : j = 1, 2, \dots, n\}$ induces an n -cycle in $\text{cor}(G) \square C_n$, since $\pi(w_m) = w_m$. Let A be a γ -set of $\langle S \rangle$ and $D = D' \cup A$. Then D is a dominating set of $\text{cor}(G) \square C_n$ of cardinality $|D| = qn + \lceil \frac{n}{3} \rceil = \lceil \frac{mn}{3} \rceil$.

Case 3: $m \equiv 2 \pmod{3}$. Note that the sets $S_i = \{(w_i, u_j) : j = 1, 2, \dots, n\}$, $i = m-1, m$, each induce an n -cycle in $\text{cor}(G) \square C_n$, since $\pi(w_i) = w_i$. Let A_i be a γ -set of $\langle S_i \rangle$ and $D = D' \cup A_{m-1} \cup A_m$. Then D is a dominating set of $\text{cor}(G) \square C_n$ of cardinality $|D| = qn + 2\lceil \frac{n}{3} \rceil \leq \lceil \frac{mn}{3} \rceil + 1$. (The subcase $n \equiv 1 \pmod{3}$ produces an equality.) ■

If G is a graph such that $\gamma(G) \leq \lfloor \frac{|V(G)|}{3} \rfloor$ and $n \equiv 0 \pmod{3}$, then $\text{cor}(G)$ satisfies a Vizing inequality with respect to C_n for any permutation π . Following a similar argument to that used in the above proof, it is verified easily that $\gamma(\text{cor}(G) \square C_n) = \gamma(\text{cor}(G))\gamma(C_n)$ for some π .

Since generalized Cartesian products $G \square H$ and $H \square G$ are not necessarily isomorphic, it is worth investigating the graph $G \square \text{cor}(H)$. It turns out that, for any permutation π of $V(G)$,

G satisfies a Vizing inequality with respect to the corona of any graph H . In particular, $\gamma(C_n \boxtimes \text{cor}(K_m)) \geq m \lceil \frac{n}{3} \rceil$.

Proposition 2.4.4 *For any graphs G and H and permutation π of $V(G)$, $\gamma(G \boxtimes \text{cor}(H)) \geq |V(H)|\gamma(G)$.*

Proof: Let G and H be graphs of order m and n respectively, $V(G) = \{v_1, v_2, \dots, v_m\}$ and $V(\text{cor}(H)) = \{u_i, w_i : i = 1, 2, \dots, n\}$ such that $u_i w_i \in E(\text{cor}(H))$ for every i , and $\langle \{u_1, u_2, \dots, u_n\} \rangle \cong H$. Denote by G_i the G -layer corresponding to w_i and let D be any dominating set of $G \boxtimes \text{cor}(H)$. For any $i = 1, 2, \dots, n$, at least $\gamma(G)$ vertices in D are required to dominate G_i . For each i , none of these vertices dominates any vertex in a different layer G_j , since the vertices w_1, w_2, \dots, w_n are independent with disjoint neighbourhoods in $\text{cor}(H)$. Therefore $|D| \geq |V(H)|\gamma(G)$. ■

A graph G is called *vertex-critical* if for any vertex $v \in V(G)$, $\gamma(G - v) = \gamma(G) - 1$. If G is vertex-critical and H is complete, then, as shown below, equality holds in Proposition 2.4.4, i.e. $\gamma(G \boxtimes \text{cor}(K_n)) = \gamma(G)\gamma(\text{cor}(K_n)) = n\gamma(G)$. With notation as in Proposition 2.4.4, consider the ordering $u_1, \dots, u_n, w_1, \dots, w_n$ on the vertices of $\text{cor}(K_n)$ for convenience.

Proposition 2.4.5 *For any vertex-critical graph G and permutation π of $V(G)$, $\gamma(G \boxtimes \text{cor}(K_n)) = n\gamma(G)$ for $n \geq |V(G)|$.*

Proof: Let G be a vertex-critical graph of order m . Denote by G_x the G -layer corresponding to $x \in V(\text{cor}(K_n))$ and $V_x = V(G_x)$. Also, let H_i denote the i^{th} $\text{cor}(K_n)$ -layer (the layer containing (v_i, u_1)) and $U_i = V(H_i)$. Construct a dominating set D of $G \boxtimes \text{cor}(K_n)$ of cardinality $n\gamma(G)$ as below. Observe that there exists a set X_0 of cardinality m with the property that

- (a) $|X_0 \cap V_{u_j}| = 1$ for $j = 1, 2, \dots, m$ (in other words X_0 has exactly one vertex in each of the first m G -layers) and

- (b) $|X_0 \cap U_i| = 1$ for $i = 1, 2, \dots, m$ (in other words X_0 has exactly one vertex in each $\text{cor}(K_n)$ -layer).

Since $n \geq m$, every vertex in X_0 has the form (v_i, u_j) (and is in the n -clique in its $\text{cor}(K_n)$ -layer). Let $X_0 = \{(v_{i_j}, u_j) : j = 1, 2, \dots, m\}$ and note that the vertex (v_{i_j}, u_j) is adjacent to $(\pi^n(v_{i_j}), w_j)$ (which is a vertex in the G -layer G_{w_j}), $j = 1, 2, \dots, m$. Let $G'_{w_j} = G_{w_j} - (\pi^n(v_{i_j}), w_j)$ and X_j be a γ -set of G'_{w_j} . Since G is vertex-critical, it follows that $|X_j| = \gamma(G) - 1$. Lastly, let X_j be a γ -set of G_{w_j} for $j > m$. Then

- (i) for each $j = 1, 2, \dots, m$, $X_j \succ V_{w_j} - (\pi^n(v_{i_j}), w_j)$;
- (ii) for each $j = 1, 2, \dots, m$, $X_0 \succ (\pi^n(v_{i_j}), w_j)$, since $(v_{i_j}, u_j) \in X_0$ is adjacent to $(\pi^n(v_{i_j}), w_j)$;
- (iii) for each $j > m$, $X_j \succ V_{w_j}$;
- (iv) by (a), (b), $X_0 \succ V_{u_j}$ for each $j = 1, 2, \dots, n$, since any vertex (v_i, u_j) is in a $\text{cor}(K_n)$ -layer with some vertex of X_0 .

By (i) – (iv), $D = \cup_{j=0}^n X_j$ is a dominating set of $G \boxtimes \text{cor}(K_n)$ of cardinality $|D| = m + m(\gamma(G) - 1) + (n - m)\gamma(G) = n\gamma(G)$. ■

As mentioned in Section 1.2.1, Jacobson and Kinch [47] established the lower bound $\gamma(G \square H) \geq \max\{\gamma(G)\rho_2(H), \rho_2(G)\gamma(H)\}$, thereby showing that any tree satisfies Vizing’s conjecture (since $\gamma(T) = \rho_2(T)$ for any tree T). As shown below, a similar argument proves that $\gamma(G \boxtimes H) \geq \gamma(G)\rho_2(H)$ for any permutation π and that for some π , $\gamma(G \boxtimes H) \geq \rho_2(G)\gamma(H)$. In other words, a Vizing inequality holds between two trees for all permutations, and there exist permutations π (other than the identity permutation) such that a tree satisfies a Vizing inequality with respect to any graph.

Proposition 2.4.6 *For any graphs G and H and permutation π of $V(G)$, $\gamma(G \boxtimes H) \geq \gamma(G)\rho_2(H)$.*

Proof: Let $\{w_1, w_2, \dots, w_\rho\}$ be a maximum 2-packing of H . Then the sets $N[w_i]$, $i = 1, 2, \dots, \rho$ are disjoint in H , so that the sets $S_i = N[w_i] \times V(G)$ are disjoint in $G \boxtimes H$. Let G_i denote the G -layer of $G \boxtimes H$ corresponding to w_i . Since $V(G_i)$ is only dominated by S_i , the desired inequality follows. ■

Proposition 2.4.7 *Let G and H be any graphs and S be a maximum 2-packing of G . Then $\gamma(G \boxtimes H) \geq \rho_2(G)\gamma(H)$ for any permutation π of $V(G)$ such that $\pi(S) = S$.*

Proof: Let $S = \{w_1, w_2, \dots, w_\rho\}$ be a maximum 2-packing of G and $S_i = p_G^{-1}(w_i)$, $i = 1, 2, \dots, \rho$. Since the sets $N[w_i]$, $i = 1, 2, \dots, \rho$, are disjoint in G and $\pi(S) = S$, it follows that the sets $N[S_i] = N[w_i] \times V(H)$, $i = 1, 2, \dots, \rho$, are disjoint in $G \boxtimes H$. Since S_i is only dominated by $N[S_i]$, the desired inequality follows. ■

Jacobson and Kinch [46] established the lower bound $\gamma(G \square H) \geq \max\{\frac{|V(H)|}{1+\Delta(H)}\gamma(G), \frac{|V(G)|}{1+\Delta(G)}\gamma(H)\}$. This section is concluded by stating a similar lower bound for $\gamma(G \boxtimes H)$. For the generalized prism πG of a graph G , Burger, Mynhardt and Weakley [5] noted that $\gamma(G) \leq \gamma(\pi G) \leq 2\gamma(G)$, as mentioned in Section 1.2.3. Graphs attaining the upper bound for every permutation are called universal doublers.

Proposition 2.4.8 *Let G and H be any graphs and π a permutation of $V(G)$. If $\gamma(\pi G) \geq k$, then $\gamma(G \boxtimes H) \geq \frac{k}{2} \frac{\delta(H)}{\Delta(H)^2} |V(H)|$ for any permutation π of $V(G)$.*

Proof: Let $E(H) = \{e_1, e_2, \dots, e_{|E(H)|}\}$ and V_u denote the vertex set of the G -layer corresponding to $u \in V(H)$. Also, let D be a dominating set of $G \boxtimes H$. For $e \in E(H)$, suppose vertices u and w of H are incident with e , and let D_e denote the set of vertices in

D that dominate the generalized prism induced by $V_u \cup V_w$ in $G \boxtimes H$. In other words, let $D_e = D \cap N[V_u \cup V_w]$. It is shown that, for any edge $e \in E(H)$,

$$|D_e| \geq k. \tag{2.1}$$

This is obvious if $D_e \subseteq V_u \cup V_w$. Suppose there exists a vertex $x \in D_e - (V_u \cup V_w)$. Then x is adjacent to at most one vertex in V_u and at most one vertex in V_w . If $|N(x) \cap (V_u \cup V_w)| = 1$, say $N(x) \cap (V_u \cup V_w) = \{y\}$, then $D'_e = (D_e - \{x\}) \cup \{y\} \succ V_u \cup V_w$, so that $|D_e| \geq |D'_e|$. If $|N(x) \cap (V_u \cup V_w)| = 2$, say $N(x) \cap (V_u \cup V_w) = \{y, z\}$, then x, y and z are in the same H -layer and y is necessarily adjacent to z . It follows that again $D'_e = (D_e - \{x\}) \cup \{y\} \succ V_u \cup V_w$, and $|D_e| \geq |D'_e|$. The result follows by repeating this argument for all $x \in D_e - (V_u \cup V_w)$.

Now, let N denote the value obtained by adding, over all edges $e = uw$ in H , the number of vertices in D that dominate the generalized prism induced by $V_u \cup V_w$ (the preimage corresponding to e in $G \boxtimes H$). Two expressions for N are obtained. First, observe that

$$N = \sum_{e_i \in E(H)} |D_e| \geq k|E(H)|. \tag{2.2}$$

For a vertex $(v, u) \in V(G \boxtimes H)$, let $g(u) = \{w \in V(H) : 1 \leq d(u, w) \leq 2\}$. Then $g(u)$ denotes the number of generalized prisms in $G \boxtimes H$ (induced by the union of two G -layers) that (v, u) is either in or adjacent to. So

$$N = \sum_{(u,v) \in D} g(u) \leq \sum_{(v,u) \in D} \Delta(H)^2 = \Delta(H)^2 |D|. \tag{2.3}$$

By (2.2) and (2.3), $k|E(H)| \leq \Delta(H)^2 |D|$, so that $\gamma(G \boxtimes H) \geq \frac{k}{\Delta(H)^2} |E(H)|$. The desired inequality now follows from the fact that $2|E(H)| = \sum_{u \in V(H)} \deg(u) \geq \delta(H) |V(H)|$. ■

If H is r -regular with an efficient γ -set, then $\delta(H) = \Delta(H) = r$ and $|V(H)| = (r+1)\gamma(H)$, so that $\gamma(G \boxtimes H) \geq \frac{k}{2}\gamma(H)$ in this case. It follows that any universal doubler satisfies a Vizing inequality with respect to such H for any permutation, since $k = 2\gamma(G)$ yields $\gamma(G \boxtimes H) \geq \gamma(G)\gamma(H)$.

2.5 Chapter Summary

An initial study of the generalized Cartesian product defined in Section 1.1 was conducted in this chapter. In Section 2.2, the natural isomorphisms between two generalized Cartesian product graphs were explored. The characterization by Lee and Sohn [54] was applied to this graph product and various corollaries were discussed. Section 2.3 explored the diameter of the generalized Cartesian product, comparing it to that of the corresponding Cartesian product graph. Necessary and sufficient conditions for when the respective diameters are equal, were provided. Lastly, in Section 2.4 the validity of an inequality similar to Vizing's conjecture for Cartesian products was explored briefly. Illustrating some of the differences between the two products further motivated the study of generalized Cartesian product graphs. Various results were provided to illustrate the relationship between the domination number of a generalized Cartesian product and the domination numbers of the respective graphs.

Chapter 3

Fixers and Multipliers

3.1 Introduction

In 2004, Hartnell and Rall [41] characterized prism fixers, i.e. graphs G for which $\gamma(G \square K_2) = \gamma(G)$, and noted that $\gamma(G \square K_n) \geq \min\{|V(G)|, \gamma(G) + n - 2\}$. A graph G is called a consistent fixer if $\gamma(G \square K_n) = \gamma(G) + n - 2$ for each n such that $2 \leq n < |V(G)| - \gamma(G) + 2$. This class of graphs is characterized in Section 3.2. Also in 2004, Burger, Mynhardt and Weakley [5] characterized prism doublers, i.e. graphs G for which $\gamma(G \square K_2) = 2\gamma(G)$. In general $\gamma(G \square K_n) \leq n\gamma(G)$ for any $n \geq 2$. A graph attaining equality in this bound is called a Cartesian n -multiplier. This class of graphs is characterized in Section 3.3. Burger, Mynhardt and Weakley also characterized universal doublers, i.e. graphs for which $\gamma(\pi G) = 2\gamma(G)$ for any π . As in the case of the Cartesian product, $\gamma(G \boxtimes K_n) \leq n\gamma(G)$ for any $n \geq 2$ and permutation π , and a graph attaining equality in this upper bound for all π is called a universal multiplier. Such graphs are characterized in Section 3.4, and a similar problem for the product $G \boxtimes C_n$ is considered in Section 3.5. A graph is called a universal fixer if $\gamma(\pi G) = \gamma(G)$ for any permutation π . In general, $\gamma(G \boxtimes H) \geq \gamma(G)$, and a graph G attaining equality in this lower bound for some permutation π is called a π -

H -fixer. Section 3.6 conducts a brief investigation into the existence of universal H -fixers, i.e. graphs that are π - H -fixers for some H and all permutations π of $V(G)$.

3.2 Cartesian Fixers

The domination number $\gamma(G \square K_2)$ of the prism of G lies between $\gamma(G)$ and $2\gamma(G)$. The edgeless graph $G = \overline{K_m}$ attains equality in the lower bound, whereas $\gamma(K_m \square K_2) = 2\gamma(G)$. In 2004, Hartnell and Rall [41] characterized graphs G , called *prism fixers*, for which $\gamma(G \square K_2) = \gamma(G)$. Recall that a γ -set D of G is called a *symmetric γ -set* if D can be partitioned into two nonempty subsets D_1 and D_2 such that $V(G) - N[D_1] = D_2$ and $V(G) - N[D_2] = D_1$. This is written as $D = D_1 \cup D_2$ for convenience. A symmetric γ -set $D = D_1 \cup D_2$ is called *primitive* if $|D_i| = 1$ for at least one i .

Theorem 3.2.1 [41] *A connected graph G is a prism fixer if and only if G has a symmetric γ -set.* ■

Hartnell and Rall generalized the lower bound for $\gamma(G \square K_2)$ to $\gamma(G \square K_n)$, and confirmed that the lower bound is sharp by providing a family of graphs attaining equality.

Theorem 3.2.2 [41] *For any graph G and any $n \geq 2$, $\gamma(G \square K_n) \geq \min\{|V(G)|, \gamma(G) + n - 2\}$.* ■

Note that $\gamma(G \square K_n) = |V(G)|$ for the edgeless graph $G = \overline{K_m}$. Also, if $n \geq |V(G)| - \gamma(G) + 2$, then $\min\{|V(G)|, \gamma(G) + n - 2\} = |V(G)|$. A minimum domination strategy is to take all vertices in a single G -layer as a dominating set, hence $\gamma(G \square K_n) = |V(G)|$.

For $2 \leq n < |V(G)| - \gamma(G) + 2$, Theorem 3.2.2 gives a nontrivial lower bound, and a graph G is called a *Cartesian n -fixer* if $\gamma(G \square K_n) = \gamma(G) + n - 2$. Henceforth, a Cartesian

n -fixer will simply be referred to as an n -fixer. Furthermore, if G is an n -fixer for each n such that $2 \leq n < |V(G)| - \gamma(G) + 2$, then G is called a *consistent fixer*. These graphs are characterized, and graphs that are n -fixers for only some values of n in the range $2 \leq n < |V(G)| - \gamma(G) + 2$ are also investigated.

3.2.1 Consistent Fixers

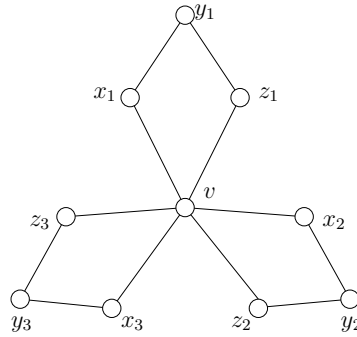


Figure 3.1: The graph G_3 .

Hartnell and Rall [41] provided examples of graphs that show that the lower bound in Theorem 3.2.2 is sharp. Let G_k be the graph with vertex set $V(G_k) = \{v\} \cup \{x_i, y_i, z_i : i = 1, 2, \dots, k\}$, and edge set $\{vx_i, x_iy_i, y_iz_i, z_iv : i = 1, 2, \dots, k\}$. (The 4-cycles $G_k[\{v, x_i, y_i, z_i\}]$ share a common vertex v , $i = 1, 2, \dots, k$.) Then $\gamma(G_k) = k + 1$ and $D = \{(y_i, u_1) : i = 1, 2, \dots, k\} \cup \{(v, u_j) : j = 2, 3, \dots, n\}$ is a dominating set of $G_k \square K_n$ of cardinality $k + n - 1 = \gamma(G_k) + n - 2$. The graph G_3 is illustrated in Figure 3.1. If $k > \frac{n-2}{2}$, then $|V(G_k)| = 3k + 1 > k + n - 1$ and hence $\gamma(G_k \square K_n) = \gamma(G_k) + n - 2$.

For the graph G_3 in Figure 3.1, let $D_1 = \{y_1, y_2, y_3\}$ and $D_2 = \{v\}$, and note that $D = D_1 \cup D_2$ is a primitive symmetric γ -set of G_3 . In general, any graph G that has a primitive symmetric γ -set satisfies $\gamma(G \square K_n) = \gamma(G) + n - 2$ for any $2 \leq n < |V(G)| - \gamma(G) + 2$: Let $V(K_n) = \{u_1, u_2, \dots, u_n\}$ and $D = D_1 \cup D_2$ be a primitive symmetric γ -set of G with $D_2 = \{x\}$. Figure 3.2 illustrates the dominating set $W = \{(v, u_1) : v \in D_1\} \cup \{(x, u_i) : i =$

$2, 3, \dots, n\}$ of $G \square K_n$ of cardinality $\gamma(G) + n - 2$. In the first G -layer, the set $Y = V(G) - D$ is dominated by $\{(v, u_1) : v \in D_1\}$, and in the i^{th} G -layer Y is dominated by (x, u_i) , $i \geq 2$. The question now arises whether graphs with primitive symmetric γ -sets are the only n -fixers. The characterization will show that this is not the case.

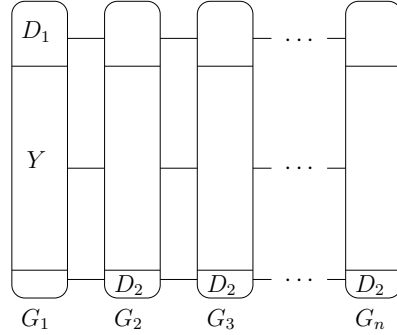


Figure 3.2: A domination strategy for $G \square K_n$ if G has a primitive symmetric γ -set.

Some useful properties of a graph having a symmetric γ -set are stated first.

Observation 3.2.1 [41]

- (i) Let G be a connected graph with symmetric γ -set $D = D_1 \cup D_2$ and let $Y = V(G) - D$.
Then
 - (a) $N[D_i] = D_i \cup Y$, $i = 1, 2$;
 - (b) D is an independent set;
 - (c) the sets $\{N(x)\}_{x \in D_i}$ are disjoint and form a partition of Y .
 - (d) each vertex in D is adjacent to at least two vertices in Y .
- (ii) Let G be a graph with at least one symmetric γ -set, but no primitive symmetric γ -set, and let $Y = V(G) - D$. Then $\gamma(G[Y]) > 1$.
- (iii) If G is a 2-fixer and $W = W_1 \cup W_2$ is a γ -set of $G \square K_2$, then $p(W_1) \cup p(W_2)$ is a symmetric γ -set of G . ■

Suppose G is a 2-fixer with no primitive symmetric γ -set and $\gamma(G \square K_3) = \gamma(G) + 1$. Then a minimum domination strategy for the Cartesian product $G \square K_3$ will never be to take a γ -set of $G \square K_2$ and select one vertex in the third G -layer, as is shown next.

Lemma 3.2.1 *Let G be a connected 3-fixer with symmetric γ -set $D = D_1 \cup D_2$, but no primitive symmetric γ -set. Then no γ -set $W = W_1 \cup W_2 \cup W_3$ of $G \square K_3$ has $p(W_1) = D_1$, $p(W_2) = D_2$ and $|W_3| = 1$.*

Proof: Let $D = D_1 \cup D_2$ be a symmetric γ -set of G with $|D_1|, |D_2| \geq 2$ and let $Y = V(G) - D$. Suppose $W = W_1 \cup W_2 \cup W_3$ is a γ -set of $G \square K_3$, with $p(W_1) = D_1$, $p(W_2) = D_2$ and $W_3 = \{(x, u_3)\}$. Then $x \succ Y$. If $x \notin D$, then $x \in Y$ and so $\gamma(G[Y]) = 1$, contradicting Observation 3.2.1(ii). So assume $x \in D$, say $x \in D_2$, and let $z \in D_2 - \{x\}$. Then z is adjacent to some vertex in Y , hence x and z have a common neighbour in Y , contradicting Observation 3.2.1(i)(c). ■

Before providing a characterization of consistent fixers, it is noted that only connected graphs G need to be considered.

Lemma 3.2.2 *Let G be disconnected and $n \geq 3$ such that $\gamma(G) + n - 2 < |V(G)|$. Then G is a Cartesian n -fixer if and only if it consists of exactly one nontrivial connected component that is a Cartesian n -fixer.*

Proof: Let F_1, F_2, \dots, F_k denote the connected components of G , with F_1 a (nontrivial) Cartesian n -fixer and F_2, F_3, \dots, F_k each consisting of a single isolated vertex. Then $\gamma(F_1 \square K_n) = \gamma(F_1) + n - 2$ and $\gamma(F_1) + n - 2 < |V(F_1)|$. Also, let $m_i = |V(F_i)|$ and $\gamma_i = \gamma(F_i)$ for $i = 1, 2, \dots, k$. Clearly $\gamma(G \square K_n) = \sum_{i=1}^k \gamma(F_i \square K_n) = \gamma_1 + n - 2 + (k - 1) = \gamma(G) + n - 2$, so that G is a Cartesian n -fixer.

Conversely, suppose G is a Cartesian n -fixer. Let l be such that $\gamma_i + n - 2 < m_i$ for $i = 1, 2, \dots, l$ and $\gamma_i + n - 2 \geq m_i$ for $i = l + 1, \dots, k$. Then

$$\begin{aligned} \sum_{i=1}^k \gamma_i + n - 2 &= \gamma(G) + n - 2 \\ &= \gamma(G \square K_n) \\ &= \sum_{i=1}^k \gamma(F_i \square K_n) \\ &\geq \sum_{i=1}^l (\gamma_i + n - 2) + \sum_{i=l+1}^k m_i \\ &= \sum_{i=1}^l \gamma_i + l(n - 2) + \sum_{i=l+1}^k m_i, \end{aligned}$$

so that $0 \leq \sum_{i=l+1}^k (m_i - \gamma_i) \leq (1-l)(n-2)$. Since $l \geq 1$ and $m_i \geq \gamma_i$ for every i , it follows that $l = 1$ and $m_i = \gamma_i$ for $i \geq 2$. ■

Also, assume that G has order at least three; since $\gamma(G) \leq \frac{1}{2}|V(G)|$ for any connected graph G , this requirement ensures that a value $n \geq 3$ is included in the range $2 \leq n < |V(G)| - \gamma(G) + 2$.

Theorem 3.2.3 *Let G be a connected graph of order at least 3. Then G is a consistent fixer if and only if*

- (i) G has a primitive symmetric γ -set, or
- (ii) G has symmetric γ -sets, none of which is primitive, and G has a dominating set $X = X_1 \cup X_2 \cup X_3$ with the following properties:
 - (a) $X_i \succ V(G) - X$, $i = 1, 2, 3$;
 - (b) for each $i = 1, 2, 3$, the sets $\{N(x) - X\}_{x \in X_i}$ are disjoint and form a partition of $V(G) - X$;

(c) the sets X_i are disjoint and $|X| = |X_1| + |X_2| + |X_3| = \gamma(G) + 1$;

(d) $|X_2| = |X_3| = 1$.

Proof: Let G be a consistent fixer. Then by Theorem 3.2.1, G has a symmetric γ -set $D = D_1 \cup D_2$. Suppose $|D_1|, |D_2| \geq 2$ for any such set D . It is shown that (ii) holds.

Since G is also a Cartesian 3-fixer, there exists a minimum dominating set $W = W_1 \cup W_2 \cup W_3$ of $G \square K_3$ of cardinality $\gamma(G) + 1$. Let $X_i = p(W_i)$, $i = 1, 2, 3$, $X = X_1 \cup X_2 \cup X_3$ and $Y = V(G) - X$.

Then $X \subseteq V(G)$ is a dominating set of G of cardinality at most $\gamma(G) + 1$, i.e. $\gamma(G) \leq |X| \leq \gamma(G) + 1$. If $Y = \emptyset$, then $|V(G)| = |X| \leq \gamma(G) + 1$, contradicting the statement $3 < |V(G)| - \gamma(G) + 2$. Therefore $Y \neq \emptyset$, and so to dominate $p^{-1}(Y)$, $W_i \neq \emptyset$ for each i . Hence $X_i \neq \emptyset$ and, moreover, $X_i \succ Y$ for each $i = 1, 2, 3$. Thus (a) holds.

Without loss of generality, assume that $|X_1| \geq |X_2| \geq |X_3|$ and that W has been chosen so that $|X_1|$ is as large as possible. Since $\gamma(G) \leq |X| \leq \gamma(G) + 1$,

$$\text{at most one vertex of } X \text{ occurs in more than one set } X_i. \quad (3.1)$$

Similarly, no vertex occurs in all three X_i , i.e.

$$X_1 \cap X_2 \cap X_3 = \emptyset. \quad (3.2)$$

The following statement is proved next:

$$\text{Each vertex in } X_2 \cup X_3 \text{ is adjacent to some vertex in } Y. \quad (3.3)$$

Suppose there exists $x \in X_2$ that is not adjacent to any vertex in Y , and w_2 is a vertex of W_2 such that $p(w_2) = x$. (The argument is the same if $x \in X_3$.) If $x \in X_1$ and w_1

is a vertex of W_1 such that $p(w_1) = x$, then $W - \{w_1\}$ is a dominating set of $G \square K_3$ of cardinality $\gamma(G)$, which is impossible by Theorem 3.2.2. Thus $x \notin X_1$. But then $W' = (W_1 \cup \{w_2\}) \cup (W_2 - \{w_2\}) \cup W_3$ is a minimum dominating set of $G \square K_3$ such that $X'_1 = p(W_1 \cup \{w_2\}) = X_1 \cup \{x\}$ has larger cardinality than X_1 , contradicting the choice of W . Thus (3.3) holds.

(b) Suppose two distinct vertices $u, v \in X_i$ are both adjacent to some vertex $y \in Y$. By (a), y is adjacent to a vertex in each X_i . By (3.1) and (3.2), at least one $X_j, j \neq i$, contains a neighbour w of y such that $w \notin \{u, v\}$. But $X_k \succ Y, k \neq i, j$, so $(X - \{u, v, w\}) \cup \{y\}$ is a dominating set of G that has cardinality $\gamma(G) - 1$, a contradiction. Hence each vertex $y \in Y$ is dominated by exactly one vertex from X_i , and (b) follows.

(c) Only $X_2 \cap X_3 = \emptyset$ is proved; the proofs that $X_1 \cap X_2 = \emptyset$ and $X_1 \cap X_3 = \emptyset$ are similar. It will follow that $|X| = |X_1| + |X_2| + |X_3| = \gamma(G) + 1$. Suppose there exists a vertex $z \in X_2 \cap X_3$. Then $|X| = \gamma(G)$ and, by (3.1) and (3.2), $X_1 \cap (X_2 \cup X_3) = \emptyset$, so that $X = X_1 \cup (X_2 \cup X_3)$ is a symmetric γ -set of G .

If $|X_3| = 1$, then $X_3 = \{z\} \subseteq X_2$ and $X = X_1 \cup X_2$. By (a), z dominates all of Y . But $z \in X_2$, and so (b) implies that $X_2 = \{z\}$, i.e. $|X_2| = 1$. Then X is a primitive symmetric γ -set, which is not the case under consideration. Therefore $|X_3| \geq 2$; say $w, z \in X_3$. By (3.1), $w \notin X_1 \cup X_2$, and by (3.3), w is adjacent to some vertex in Y . Since $X_2 \succ Y$, there exists $v \in X_2$ such that v and w have a common neighbour in Y . This contradicts Observation 3.2.1(i)(c) for the symmetric γ -set $X = X_1 \cup (X_2 \cup X_3)$. Therefore $X_2 \cap X_3 = \emptyset$.

(d) Suppose that $|X_2| \geq 2$. Then $|X_1| \geq 2$. Let $y_1 \in Y$ and choose $x_1 \in X_1, x_2 \in X_2$ such that x_1 and x_2 are both adjacent to y_1 . Since $X_3 \succ Y$, the set $X' = (X - \{x_1, x_2\}) \cup \{y_1\}$ is a dominating set of G of cardinality $\gamma(G)$, i.e. a γ -set of G . It is shown that

$$\{x_1, x_2\} \succ Y. \tag{3.4}$$

Suppose to the contrary that $y \in Y$ is not adjacent to either x_1 or x_2 . Then there exist $x'_1 \in X_1 - \{x_1\}$ and $x'_2 \in X_2 - \{x_2\}$ adjacent to y , so that $(X' - \{x'_1, x'_2\}) \cup \{y\}$ is a dominating set of G of cardinality $\gamma(G) - 1$, which is impossible.

Let $v \in X_2 - \{x_2\}$. By (3.3) there exists a vertex $y_2 \in Y$ adjacent to v . By (b) y_2 is not adjacent to x_2 and so, by (3.4), y_2 is adjacent to x_1 . It follows similar to (3.4) that $\{x_1, v\} \succ Y$. But then any vertex in Y not adjacent to x_1 is adjacent to both x_2 and v , which is impossible by (b). Thus $x_1 \succ Y$, and (b) implies that $|X_1| = 1$, a contradiction. Therefore $|X_2| = 1$ which, by the choice of the X_i , also implies that $|X_3| = 1$.

Conversely, let G be a graph that satisfies the conditions of the statement and $V(K_n) = \{u_1, u_2, \dots, u_n\}$. If G has a symmetric γ -set $D = D_1 \cup D_2$ with $D_2 = \{x\}$, then the set $W = \{(v, u_1) : v \in D_1\} \cup \{(x, u_i) : i = 2, 3, \dots, n\}$ is a dominating set of $G \square K_n$ of cardinality $\gamma(G) + n - 2$, as illustrated in Figure 3.2.

Suppose that $|D_1|, |D_2| \geq 2$ and that G has a set $X = X_1 \cup X_2 \cup X_3$ with the stated properties. Let $X_2 = \{x_2\}$ and $X_3 = \{x_3\}$. Then the set

$$W = \{(v, u_1) : v \in X_1\} \cup \{(x_2, u_2)\} \cup \{(x_3, u_i) : i = 3, 4, \dots, n\}$$

is a dominating set of $G \square K_n$ of cardinality $\gamma(G) + n - 2$. ■

The dominating set $X = X_1 \cup X_2 \cup X_3$ in Theorem 3.2.3(ii) has the following additional properties.

Proposition 3.2.1 *Let G be a connected graph of order at least 3. If G is a consistent fixer with no primitive symmetric γ -set, then the dominating set $X = X_1 \cup X_2 \cup X_3$ in Theorem 3.2.3(ii) has the following properties:*

- (i) $X_1 \cup X_2$ and $X_1 \cup X_3$ are independent sets;

(ii) $\gamma(G[N(x)]) \geq 2$ for every $x \in X_1$;

(iii) for some $x \in X_1$, $G[N(x)]$ has a γ -set, $\{y_1, y_2\}$ say, such that for every $x' \in X_1 - \{x\}$,

(a) $y_1 \succ N(x')$ and $N(y_2) \cap N(x') = \emptyset$, or

(b) $y_2 \succ N(x')$ and $N(y_1) \cap N(x') = \emptyset$.

Proof: Say $X_2 = \{x_2\}$, $X_3 = \{x_3\}$, $Y = V(G) - X$, and note that

$$x_i \succ Y, \quad i = 2, 3. \quad (3.5)$$

(i) Consider any symmetric γ -set $D = D_1 \cup D_2$ of G and recall that $|D_i| \geq 2$. Define $Y' = V(G) - D$. Comparing D and X , it is shown next that

$$|D_i \cap Y| = 1 \text{ for } i = 1, 2, \quad |D \cap X_1| = \gamma(G) - 2 = |X_1| - 1, \quad \text{and} \quad |X_1 \cap Y'| = 1. \quad (3.6)$$

Firstly, $\{x_2, x_3\} \cap D = \emptyset$: Suppose $x_2 \in D$; without loss of generality say $x_2 \in D_2$. Then (3.5) and Observation 3.2.1(i)(b) imply that $Y \cap D = \emptyset$. Now if $x_3 \in D$, then Observation 3.2.1(i)(c) implies that $x_3 \in D_1$ and that the only vertices in $X_1 \cap D$ are vertices that are nonadjacent to all vertices in Y . But $|X| = \gamma(G) + 1$, $|X_1| = \gamma(G) - 1$ and $|D| = \gamma(G)$, so that $\gamma(G) - 2$ vertices in X_1 are in D . Therefore exactly one vertex in X_1 , say x_1 , is adjacent to vertices in Y . By Theorem 3.2.3(ii)(a), $x_1 \succ Y$. Furthermore, $x_1 \in Y'$ by Observation 3.2.1(i)(c). If there exists a $v \in X_1 - \{x_1\}$, then $v \in D$, hence v is adjacent to at least two vertices in Y' by Observation 3.2.1(i)(d). Since $Y' - \{x_1\} = Y$, this is a contradiction. So $X_1 = \{x_1\}$ and it follows that D is a primitive symmetric γ -set, a contradiction. Therefore $x_3 \notin D$ and so $D = X_1 \cup X_2$ and $V(G) - D = Y \cup \{x_3\}$.

Let $u \in D_2 - \{x_2\}$. By Observation 3.2.1(i)(d), u is adjacent to at least two vertices in Y' , so u is adjacent to some $y \in Y$. But then y is adjacent to the two vertices $x_2, u \in D_2$,

contradicting Observation 3.2.1(i)(c). Hence $x_2 \notin D$. Similarly, $x_3 \notin D$, i.e. $\{x_2, x_3\} \subseteq Y'$. Since $|X_1| = \gamma(G) - 1$, it follows that $Y \cap D \neq \emptyset$. If $|D_i \cap Y| \geq 2$ for some i , then by (3.5), two vertices in D_i have $x_2 \in Y'$ as common neighbour, contrary to Observation 3.2.1(i)(c). Thus $|D_i \cap Y| \leq 1$ for each i , so $|Y \cap D| \leq 2$. If $Y \cap D = \{y\}$, then $D = X_1 \cup \{y\}$. But by Theorem 3.2.3(ii)(a), y is adjacent to some vertex in X_1 , contradicting Observation 3.2.1(i)(b). Therefore $|Y \cap D| = 2$ and (3.6) follows.

Let $X_1 \cap Y' = \{x_1\}$ and $D_i \cap Y = \{y_i\}$, $i = 1, 2$. Then $X_1 - \{x_1\} \subseteq D$ and so $X_1 - \{x_1\}$ is independent (Observation 3.2.1(i)(b)).

Suppose x_1 is not adjacent to y_1 . Since $X_1 \succ Y$, y_1 is adjacent to some $x' \in X_1 - \{x_1\} \subseteq D$. But $y_1 \in D$ and D is independent, a contradiction. Hence x_1 is adjacent to y_1 and, similarly, to y_2 . It now follows from Observation 3.2.1(i)(c) that x_1 is not adjacent to any vertex in X_1 and so X_1 is independent.

By (3.5), x_2 and x_3 are adjacent to y_1 and y_2 , hence as in the case of x_1 , neither x_2 nor x_3 is adjacent to any vertex in $X_1 - \{x_1\}$. Since G is connected, each vertex in $X_1 - \{x_1\}$ is therefore adjacent to a vertex in Y ; since D is independent this vertex is necessarily in $Y - \{y_1, y_2\}$. Since $|D_1| \geq 2$, there exists $x_4 \in D_1 - \{y_1\}$; necessarily $x_4 \subseteq X_1 - \{x_1\}$. Let $y_4 \in Y - \{y_1, y_2\}$ be adjacent to x_4 and consider the set $X' = (X - \{x_1, x_3, x_4\}) \cup \{y_4\}$. Then $x_2 \succ Y$, $y_4 \succ x_4$ and $y_4 \succ x_3$ by (3.5). Therefore $X' \succ G - x_1$. But $|X'| < \gamma(G)$ and so $X' \not\succeq G$, i.e. $X' \not\succeq x_1$. In particular, x_2 is not adjacent to x_1 . Similarly, x_3 is not adjacent to x_1 , and the proof of (i) is complete.

(ii) Since $\gamma(G) \geq 4$, $|X_1| \geq 3$. Say $X_1 = \{x_1, x_4, x_5, \dots, x_k\}$ and define $Y_i = N(x_i)$, $i = 1, 4, 5, \dots, k$. By (i), no vertex in X_1 is adjacent to any vertex in X , so $Y_i \subseteq Y$ for each i , and since G is connected, $Y_i \neq \emptyset$. By Theorem 3.2.3(ii)(a) and (b), the sets Y_1, Y_4, \dots, Y_k partition Y . Suppose that for some i there exists a vertex $y \in Y_i$ that is adjacent to all other vertices in Y_i and consider $X' = (X - \{x_i, x_2, x_3\}) \cup \{y\}$. Then by (3.5), $y \succ Y_i \cup \{x_i, x_2, x_3\}$,

while $X_1 - \{x_i\} \succ Y - Y_i$, so that $X' \succ G$. But this is impossible, because $|X'| = \gamma(G) - 1$. This proves (ii).

(iii) As shown above, $D = \{y_1, y_2, x_4, \dots, x_k\}$ and $Y' = \{x_1, x_2, x_3\} \cup (Y - \{y_1, y_2\})$. By Observation 3.2.1(i)(c), each vertex in Y' is adjacent to exactly one vertex in each D_i . In particular, since X_1 is independent, x_1 is adjacent to y_1 and y_2 . Since the Y_i partition Y , no vertex in Y is adjacent to two vertices in X_1 . But for each $i = 4, \dots, k$, x_i is in exactly one of D_1 or D_2 , so if $x_i \in D_1 - \{y_1\}$, then each vertex in $Y_i = N(x_i)$ is also adjacent to y_2 but not to y_1 , and if $x_i \in D_2 - \{y_2\}$, then each vertex in Y_i is also adjacent to y_1 but not to y_2 . Moreover, $\{y_1, y_2\} \succ Y \supseteq Y_1 = N(x_1)$ and so, by (ii), $\{y_1, y_2\}$ is a γ -set of $N(x_1)$. Therefore (iii) holds with $x = x_1$. ■

The properties of the dominating set $X = X_1 \cup X_2 \cup X_3$ given in Theorem 3.2.3 and Proposition 3.2.1 allow one to easily construct consistent fixers without primitive symmetric γ -sets. Figure 3.3 shows a consistent fixer G that has a symmetric γ -set $D = D_1 \cup D_2$ with $|D_1| = |D_2| = 2$. In this example, $D_1 = \{y_1, x_4\}$, $D_2 = \{y_2, x_5\}$, $X_1 = \{x_1, x_4, x_5\}$, $X_2 = \{x_2\}$ and $X_3 = \{x_3\}$. Since $\Delta(G) = 6$, G has no primitive symmetric γ -set. (The existence of a primitive symmetric γ -set requires a single vertex to dominate seven vertices, since the order of G is 11 and $\gamma(G) = 4$.)

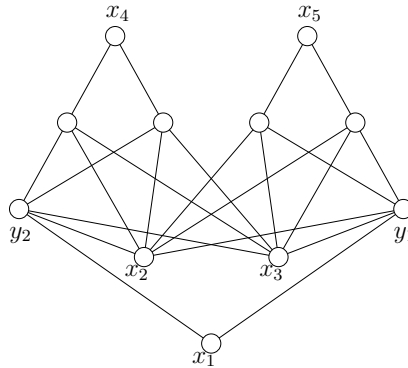


Figure 3.3: A consistent fixer with no primitive symmetric γ -set.

If G is a consistent fixer, then $G \square K_n$, $n \geq 3$, has a minimum dominating set that contains exactly one vertex in all but one of the G -layers of $G \square K_n$, as stated in the following corollary.

Corollary 3.2.1 *If G is a consistent fixer, then $G \square K_n$ has a γ -set $X = X_1 \cup \dots \cup X_n$ with $|X_i| = 1$ for $i = 2, 3, \dots, n$, where X_i lies in the i^{th} G -layer of $G \square K_n$, $i = 1, 2, \dots, n$, $n \geq 3$. ■*

3.2.2 Other Fixers

For any integer $t \geq 4$ there exist graphs that are 2-fixers and n -fixers for $t \leq n < |V(G)| - \gamma(G) + 2$, but not for $2 < n < t$. Figure 3.4 shows a graph G that is a 2-fixer and a 4-fixer, but not a 3-fixer. Each vertex x_2, x_3 and x_6 is adjacent only to the vertices y_1, y_2, a, b, c and d , but these edges are omitted in the figure for the sake of clarity. The graph has a symmetric γ -set $D = D_1 \cup D_2$ with $D_1 = \{x_4, y_1\}$ and $D_2 = \{x_5, y_2\}$. Since $\Delta(G) = 6$, G does not have a primitive symmetric γ -set. Furthermore, it is easy to verify that G does not have a set $X = X_1 \cup X_2 \cup X_3$ with the properties stated in Theorem 3.2.3, and therefore is not a 3-fixer. However, for $n \geq 4$, the set

$$W = \{(x_1, u_1), (x_4, u_1), (x_5, u_1), (x_2, u_2), (x_3, u_3)\} \cup \{(x_6, u_i) : i \geq 4\}$$

is a dominating set of $G \square K_n$ of cardinality $\gamma(G) + n - 2$, so that G is an n -fixer.

The characterization of these n -fixers is similar to that of Theorem 3.2.3.

Theorem 3.2.4 *Let G be a connected graph and $t \geq 4$. Then G is a 2-fixer and an n -fixer for $n \geq t$, but not for $2 < n < t$, if and only if*

- (i) G has symmetric γ -sets, none of which is primitive, and

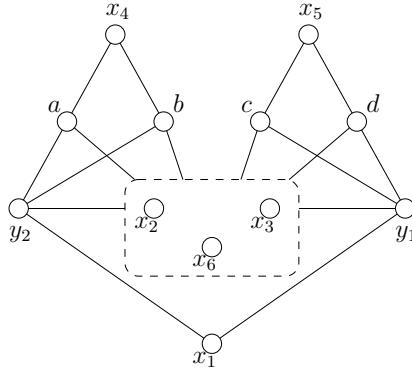


Figure 3.4: A graph that is a 2-fixer and a 4-fixer, but not a 3-fixer.

(ii) t is the smallest integer such that G has a dominating set $X = X_1 \cup \dots \cup X_t$ with the following properties:

- (a) $X_i \succ V(G) - X$, $i = 1, 2, \dots, t$;
- (b) for each $i = 1, 2, \dots, t$, the sets $\{N(x) - X\}_{x \in X_i}$ are disjoint and form a partition of $V(G) - X$;
- (c) the sets X_i are disjoint and $|X| = \sum_{i=1}^t |X_i| = \gamma(G) + t - 2$;
- (d) $|X_i| = 1$ for $i \geq 2$.

Proof: Let G be a 2-fixer and an n -fixer for $n \geq t$, but not for $2 < n < t$. Then by Theorem 3.2.1, G has a symmetric γ -set $D = D_1 \cup D_2$. Let $V(K_n) = \{u_1, u_2, \dots, u_n\}$. If G has a symmetric γ -set $D = D_1 \cup D_2$ with $D_2 = \{x\}$, then the set $W = \{(v, u_1) : v \in D_1\} \cup \{(x, u_i) : i = 2, 3, \dots, n\}$ is a dominating set of $G \square K_n$ of cardinality $\gamma(G) + n - 2$ for any $n \geq 2$, which is not the case.

Suppose there exists an integer $2 < s < t$ such that G has a dominating set $X = X_1 \cup X_2 \cup \dots \cup X_s$ with the stated properties. Let $X_i = \{x_i\}$ for $i = 2, 3, \dots, s$. Then the set

$$W = \{(v, u_1) : v \in X_1\} \cup \{(x_i, u_i) : i = 2, 3, \dots, s\}$$

is a dominating set of $G \square K_s$ of cardinality $\gamma(G) + s - 2$, so that G is also an s -fixer, a contradiction.

Since G is a Cartesian t -fixer, there exists a minimum dominating set $W = W_1 \cup W_2 \cup \dots \cup W_t$ of $G \square K_t$ of cardinality $\gamma(G) + t - 2$. Let $X_i = p(W_i)$, $i = 1, 2, \dots, t$, $X = X_1 \cup X_2 \cup \dots \cup X_t$ and $Y = V(G) - X$.

Then $X \subseteq V(G)$ is a dominating set of G of cardinality at most $\gamma(G) + t - 2$, i.e. $\gamma(G) \leq |X| \leq \gamma(G) + t - 2$. If $Y = \emptyset$, then $|V(G)| = |X| \leq \gamma(G) + t - 2$, contradicting the statement $t < |V(G)| - \gamma(G) + 2$. Therefore $Y \neq \emptyset$, and so to dominate $p^{-1}(Y)$, $W_i \neq \emptyset$ for each i . Hence $X_i \neq \emptyset$ and, moreover, $X_i \succ Y$ for each $i = 1, 2, \dots, t$. Thus (a) holds.

Without loss of generality, assume that $|X_1| \geq |X_2| \geq \dots \geq |X_t|$ and that W has been chosen so that $|X_1|$ is as large as possible. Let ε_v denote the number of sets X_i containing the vertex $v \in V(G)$, and let $k = \sum_{v \in V(G)} (\varepsilon_v - 1)$. Since $\gamma(G) \leq |X|$,

$$|X| + k = \gamma(G) + t - 2 \text{ and } 0 \leq k \leq t - 2. \tag{3.7}$$

Also, no vertex occurs in all t sets X_i , i.e.

$$X_1 \cap X_2 \cap \dots \cap X_t = \emptyset. \tag{3.8}$$

The following statement is proved next:

$$\text{Each vertex in } X_i, i \geq 2, \text{ is adjacent to some vertex in } Y. \tag{3.9}$$

Suppose there exists an $x \in X_i$ that is not adjacent to any vertex in Y , and w_i is a vertex of W_i such that $p(w_i) = x$. Then $w_i \succ p^{-1}(x)$. If $x \in X_1$ and w_1 is a vertex of W_1 such that $p(w_1) = x$, then $W - \{w_1\}$ is a dominating set of $G \square K_t$ of cardinality less than $|W|$,

which contradicts the minimality of W . Thus $x \notin X_1$. But then

$$W' = (W_1 \cup \{w_i\}) \cup W_2 \cup \dots \cup W_{i-1} \cup (W_i - \{w_i\}) \cup W_{i+1} \cup \dots \cup W_t$$

is a minimum dominating set of $G \square K_t$ such that $X'_1 = p(W_1 \cup \{w_i\}) = X_1 \cup \{x\}$ has larger cardinality than X_1 , contradicting the choice of W . Thus (3.9) holds.

(b) Suppose two distinct vertices $u, v \in X_i$ are both adjacent to some vertex $y \in Y$. By (a), y is adjacent to a vertex w_i in each X_i . Let $I = \{i : u \in X_i \text{ or } v \in X_i\}$, in other words the set of indices corresponding to sets X_i containing one or more of u, v , and note that $|I| \leq \varepsilon_u + \varepsilon_v - 1$. Also, let $J = \{1, 2, \dots, t\} - I$ and consider the vertices in $\{w_j : j \in J\}$. It follows that the number of distinct vertices w_j in $\{w_j : j \in J\}$ is at least

$$|J| - (k - (\varepsilon_u - 1) - (\varepsilon_v - 1)) \geq |J| - (k - |I| + 1) = t - k - 1.$$

So there exists a subset of indices $J' \subseteq J$ such that $|J'| \geq t - k - 1$, w_j is adjacent to y for every $j \in J'$ and the vertices $\{w_j : j \in J'\}$ are distinct. For any index $j' \in J'$, $X_{j'} \succ Y$, so that $(X - \{u, v, w_j : j \in J' - \{j'\}\}) \cup \{y\}$ is a dominating set of G that has cardinality at most $\gamma(G) - 1$, a contradiction. Hence each vertex $y \in Y$ is dominated by exactly one vertex from X_i , and (b) follows.

(c) Suppose that for some $\{i, j\} \subset \{1, 2, \dots, t\}$ and some vertex $z \in V(G)$, $z \in X_i \cap X_j$. Denote the i^{th} G -layer of $G \square K_t$ by V_i and let ϕ denote the mapping from this Cartesian product to $G \square K_{t-1}$ obtained by identifying the corresponding vertices in V_i and V_j . Then the set $\phi(W) = \{\phi(W_k) : k \neq i, j\} \cup \phi(W_i \cup W_j)$ is a dominating set of $G \square K_{t-1}$ of cardinality at most $|W| - 1 = \gamma(G) + (t - 1) - 2$, so that G is a Cartesian $(t - 1)$ -fixer – a contradiction. It follows that $k = 0$ and therefore $|X| = \sum_{i=1}^t |X_i| = \gamma(G) + t - 2$, implying that the sets X_i are disjoint.

(d) Suppose that $|X_2| \geq 2$. Then $|X_1| \geq 2$. Let $y_1 \in Y$ and choose $x_i \in X_i$, $i = 1, 2, \dots, t$, such that x_i is adjacent to y_1 for every i . Since $X_t \succ Y$, the set $X' = (X - \{x_i : i = 1, 2, \dots, t-1\}) \cup \{y_1\}$ is a dominating set of G of cardinality $\gamma(G)$, i.e. a γ -set of G . It is shown that

$$\{x_1, x_2\} \succ Y. \tag{3.10}$$

Suppose to the contrary that $y \in Y$ is adjacent to neither x_1 nor x_2 . Then there exist $x'_1 \in X_1 - \{x_1\}$ and $x'_2 \in X_2 - \{x_2\}$ adjacent to y , so that $(X' - \{x'_1, x'_2\}) \cup \{y\}$ is a dominating set of G of cardinality $\gamma(G) - 1$, which is impossible.

Let $v \in X_2 - \{x_2\}$. By (3.9) there exists a vertex $y_2 \in Y$ adjacent to v . By (b) y_2 is not adjacent to x_2 and so, by (3.10), y_2 is adjacent to x_1 . It follows similar to (3.10) that $\{x_1, v\} \succ Y$. But then any vertex in Y not adjacent to x_1 is adjacent to both x_2 and v , which is impossible by (b). Thus $x_1 \succ Y$, and (b) implies that $|X_1| = 1$, a contradiction. Therefore $|X_2| = 1$ which, by the choice of the X_i , also implies that $|X_i| = 1$ for each $i \geq 3$.

Conversely, let G be a graph that satisfies the conditions of the statement and $V(K_n) = \{u_1, u_2, \dots, u_n\}$. Since G has a symmetric γ -set $D = D_1 \cup D_2$, G is a 2-fixer. If $4 \leq s < t$ is the smallest integer such that G is a 2-fixer and an s -fixer, then by the above argument, t is not the smallest integer satisfying condition (ii), a contradiction. Suppose that G has a set $X = X_1 \cup X_2 \cup \dots \cup X_t$ with the stated properties. Let $X_i = \{x_i\}$ for $i = 2, 3, \dots, t$. Then the set

$$W = \{(v, u_1) : v \in X_1\} \cup \{(x_i, u_i) : i = 2, 3, \dots, t-1\} \cup \{(x_t, u_i) : i = t, t+1, \dots, n\}$$

is a dominating set of $G \square K_n$ of cardinality $\gamma(G) + n - 2$, and therefore G is an n -fixer for $n \geq t$. ■

Similar to Proposition 3.2.1, the set $X = X_1 \cup \dots \cup X_t$ has the following additional prop-

erties.

Proposition 3.2.2 *Let G be a connected graph and $t \geq 4$. If G is a 2-fixer and an n -fixer for $n \geq t$, but not for $2 < n < t$, and G has no primitive symmetric γ -set, then the dominating set $X = X_1 \cup \dots \cup X_t$ in Theorem 3.2.4(ii) has the following properties:*

- (i) $X_1 \cup X_i$ is an independent set, $i = 2, \dots, t$;
- (ii) $\gamma(G[N(x)]) \geq 2$ for every $x \in X_1$;
- (iii) for some $x \in X_1$, $G[N(x)]$ has a γ -set, $\{y_1, y_2\}$ say, such that for every $x' \in X_1 - \{x\}$,
 - (a) $y_1 \succ N(x')$ and $N(x') \cap N(y_2) = \emptyset$, or
 - (b) $y_2 \succ N(x')$ and $N(x') \cap N(y_1) = \emptyset$.

Proof: Say $X_i = \{x_i\}$, $i = 2, 3, \dots, t$, $Y = V(G) - X$, and note that

$$x_i \succ Y, \quad i = 2, 3, \dots, t. \quad (3.11)$$

(i) Consider any symmetric γ -set $D = D_1 \cup D_2$ of D and recall that $|D_i| \geq 2$. Define $Y' = V(G) - D$. By comparing D and X , it is shown next that

$$|D_i \cap Y| = 1 \text{ for } i = 1, 2, \quad |D \cap X_1| = \gamma(G) - 2 = |X_1| - 1, \quad \text{and} \quad |X_1 \cap Y'| = 1. \quad (3.12)$$

Firstly, $\{x_2, x_3, \dots, x_t\} \cap D = \emptyset$: Let $S = \{x_2, x_3, \dots, x_t\}$ and suppose $|S \cap D| \geq 3$. Then there exist vertices $w_1, w_2 \in S \cap D_i$ for some $i \in \{1, 2\}$. However, both w_1 and w_2 are adjacent to Y , contradicting Observation 3.2.1(i)(c).

Suppose $|S \cap D| = 2$ and let $S \cap D = \{w_1, w_2\}$. Since both w_1 and w_2 are adjacent to Y , let $w_1 \in D_1$ and $w_2 \in D_2$ without loss of generality. Also, $Y \cap D = \emptyset$ by (3.11) and

Observation 3.2.1(i)(b). Observation 3.2.1(i)(c) implies that the only vertices in $X_1 \cap D$ are vertices that are nonadjacent to all vertices in Y . But $|X| = \gamma(G) + t - 2$, $|X_1| = \gamma(G) - 1$ and $|D| = \gamma(G)$, so that $\gamma(G) - 2$ vertices in X_1 are in D . Therefore exactly one vertex in X_1 , say x_1 , is adjacent to vertices in Y . By Theorem 3.2.3(ii)(a), $x_1 \succ Y$. Furthermore, $x_1 \in Y'$ by Observation 3.2.1(i)(c). If there exists a $v \in X_1 - \{x_1\}$, then $v \in D$, hence v is adjacent to at least two vertices in Y' by Observation 3.2.1(i)(d). Since $Y' = Y \cup \{x_1\} \cup (S - \{w_1, w_2\})$, there exists an $x \in S \cap Y'$ adjacent to v . Let $y \in Y$ and consider the set $X' = (X - \{v, x_1, x_2, \dots, x_t\}) \cup \{y, x\}$. Since $y \succ S \cup \{x_1\}$, $x \succ Y \cup \{v\}$, it follows that X' is a dominating set of G of cardinality $\gamma(G) - 1$ – a contradiction.

So suppose $|S \cap D| = 1$ and let $S \cap D = \{w\}$. Without loss of generality let $w \in D_1$. Since $Y \cap D = \emptyset$ by (3.11) and Observation 3.2.1(i)(b), $|X| = \gamma(G) + t - 2$, $|X_1| = \gamma(G) - 1$ and $|D| = \gamma(G)$, it follows that $X_1 \in D$. So there exists a vertex $x_1 \in X_1 \cap D_2$ that is adjacent to some vertex in $y \in Y$. By Observation 3.2.1(i)(c) and (d), any vertex other than w in D_1 is adjacent to some vertex in $Y' - Y$, and therefore to some $x \in S - \{w\}$. Since D is not primitive, there exists such a vertex $v \in X_1 \cap D_1$ (necessarily distinct from x_1). Consider the set $X' = (X - \{v, x_1, x_2, \dots, x_t\}) \cup \{y, x\}$ and note that $y \succ S \cup \{x_1\}$, $x \succ Y \cup \{v\}$. It follows that X' is a dominating set of G of cardinality $\gamma(G) - 1$ – a contradiction. So $\{x_2, x_3, \dots, x_t\} \cap D = \emptyset$.

Since $|X_1| = \gamma(G) - 1$, it follows that $Y \cap D \neq \emptyset$. If $|D_i \cap Y| \geq 2$ for some i , then by (3.11), two vertices in D_i have $x_2 \in Y'$ as common neighbour, contrary to Observation 3.2.1(i)(c). Thus $|D_i \cap Y| \leq 1$ for each i , so $|Y \cap D| \leq 2$. If $Y \cap D = \{y\}$, then $D = X_1 \cup \{y\}$. But by Theorem 3.2.3(ii)(a), y is adjacent to some vertex in X_1 , contradicting Observation 3.2.1(i)(b). Therefore $|Y \cap D| = 2$ and (3.12) follows.

Let $X_1 \cap Y' = \{x_1\}$ and $D_i \cap Y = \{y_i\}$, $i = 1, 2$. Then $X_1 - \{x_1\} \subseteq D$ and so $X_1 - \{x_1\}$ is independent (Observation 3.2.1(i)(b)).

Suppose x_1 is not adjacent to y_1 . Since $X_1 \succ Y$, y_1 is adjacent to some $x' \in X_1 - \{x_1\} \subseteq D$. But $y_1 \in D$ and D is independent, a contradiction. Hence x_1 is adjacent to y_1 and, similarly, to y_2 . It now follows from Observation 3.2.1(i)(c) that x_1 is not adjacent to any vertex in X_1 and so X_1 is independent.

By (3.11), any $x_i \in X_i$, $i = 2, 3, \dots, t$, is adjacent to y_1 and y_2 , hence as in the case of x_1 , x_i is not adjacent to any vertex in $X_1 - \{x_1\}$. Since G is connected, each vertex in $X_1 - \{x_1\}$ is adjacent to a vertex in Y ; since D is independent this vertex is necessarily in $Y - \{y_1, y_2\}$. Since $|D_1| \geq 2$, there exists a vertex $x \in D_1 - \{y_1\}$; necessarily $x \subseteq X_1 - \{x_1\}$. Let $y \in Y - \{y_1, y_2\}$ be adjacent to x and consider the set $X' = (X - \{x, x_1, x_2, \dots, x_t\}) \cup \{x_i, y\}$. Then $x_i \succ Y$ and $y \succ \{x, x_2, \dots, x_t\}$ by (3.11). Therefore $X' \succ G - x_1$. But $|X'| < \gamma(G)$ and so $X' \not\succeq G$, i.e. $X' \not\succeq x_1$. In particular, x_i is not adjacent to x_1 , and the proof of (i) is complete.

(ii) Since $\gamma(G) \geq 4$, $|X_1| \geq 3$. Say $X_1 = \{z_1, z_2, \dots, z_k\}$, $z_1 = x_1$ and define $Y_i = N(z_i)$, $i = 1, 2, \dots, k$. By (i), no vertex in X_1 is adjacent to any vertex in X , so $Y_i \subseteq Y$ for each i , and since G is connected, $Y_i \neq \emptyset$. By Theorem 3.2.4(ii)(a) and (b), the sets Y_1, Y_2, \dots, Y_k partition Y . Suppose that for some i there exists a vertex $y \in Y_i$ that is adjacent to all other vertices in Y_i , and consider $X' = (X - \{z_i, x_2, x_3, \dots, x_t\}) \cup \{y\}$. Then by (3.11), $y \succ Y_i \cup \{z_i, x_2, x_3, \dots, x_t\}$, while $X_1 - \{z_i\} \succ Y - Y_i$, so that $X' \succ G$. But $|X'| = \gamma(G) - 1$, which is impossible. This proves (ii).

(iii) As shown above, $D = \{y_1, y_2, z_2, \dots, z_k\}$ and $Y' = \{x_1, x_2, x_3, \dots, x_t\} \cup (Y - \{y_1, y_2\})$. By Observation 3.2.1(i)(c), each vertex in Y' is adjacent to exactly one vertex in each D_i . In particular, since X_1 is independent, x_1 is adjacent to y_1 and y_2 . Since the sets Y_i partition Y , no vertex in Y is adjacent to two vertices in X_1 . But for each $i = 2, 3, \dots, k$, z_i is in exactly one of D_1 or D_2 , so if $z_i \in D_1 - \{y_1\}$, then each vertex in $Y_i = N(z_i)$ is also adjacent to y_2 but not to y_1 , and if $z_i \in D_2 - \{y_2\}$, then each vertex in Y_i is also adjacent to y_1 but not to y_2 . Moreover, $\{y_1, y_2\} \succ Y \supseteq Y_1 = N(x_1)$ and so, by (ii), $\{y_1, y_2\}$ is a

γ -set of $N(x_1)$. Therefore (iii) holds with $x = x_1$. ■

Lastly, consider graphs that are n -fixers for $n \geq t \geq 3$, but not for $n < t$. As an example, Figure 3.5 shows a graph G that is an n -fixer for $n \geq 4$ only. In this graph, each vertex x_1, x_2 and x_3 is adjacent only to the neighbours of v_1, v_2 and v_3 . It is easy to verify that $\gamma(G) = 4$, the graph does not have a symmetric γ -set, and that it is not a 3-fixer.

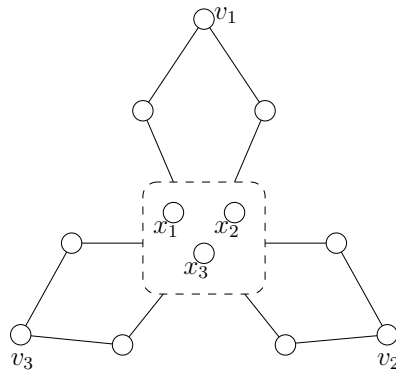


Figure 3.5: An n -fixer only for $n \geq 4$.

The following characterization describes such fixers. The proof is also similar to that of Theorem 3.2.4.

Theorem 3.2.5 *Let G be a connected graph and $t \geq 3$. Then G is an n -fixer for $n \geq t$, but not for $n < t$, if and only if G does not have a symmetric γ -set, and t is the smallest integer such that G has a dominating set $X = X_1 \cup \dots \cup X_t$ with the following properties:*

- (a) $X_i \succ V(G) - X, i = 1, 2, \dots, t;$
- (b) *for each $i = 1, 2, \dots, t$, the sets $\{N(x) - X\}_{x \in X_i}$ are disjoint and form a partition of $V(G) - X;$*
- (c) *the sets X_i are disjoint and $|X| = \sum_{i=1}^t |X_i| = \gamma(G) + t - 2;$*
- (d) $|X_i| = 1$ for $i \geq 2$.

Proof: Let G be an n -fixer for $n \geq t$, but not for $n < t$, and let $V(K_n) = \{u_1, u_2, \dots, u_n\}$. Then clearly G does not have a symmetric γ -set.

Suppose there exists an integer $2 < s < t$ such that G has a dominating set $X = X_1 \cup X_2 \cup \dots \cup X_s$ with the stated properties. Let $X_i = \{x_i\}$ for $i = 2, 3, \dots, s$. Then the set

$$W = \{(v, u_1) : v \in X_1\} \cup \{(x_i, u_i) : i = 2, 3, \dots, s\}$$

is a dominating set of $G \square K_s$ of cardinality $\gamma(G) + s - 2$, so that G is also an s -fixer, a contradiction.

Since G is a Cartesian t -fixer, there exists a minimum dominating set $W = W_1 \cup W_2 \cup \dots \cup W_t$ of $G \square K_t$ of cardinality $\gamma(G) + t - 2$. Let $X_i = p(W_i)$, $i = 1, 2, \dots, t$, $X = X_1 \cup X_2 \cup \dots \cup X_t$ and $Y = V(G) - X$.

Then $X \subseteq V(G)$ is a dominating set of G of cardinality at most $\gamma(G) + t - 2$, i.e. $\gamma(G) \leq |X| \leq \gamma(G) + t - 2$. If $Y = \emptyset$, then $|V(G)| = |X| \leq \gamma(G) + t - 2$, contradicting the statement $t < |V(G)| - \gamma(G) + 2$. Therefore $Y \neq \emptyset$, and so to dominate $p^{-1}(Y)$, $W_i \neq \emptyset$ for each i . Hence $X_i \neq \emptyset$ and, moreover, $X_i \succ Y$ for each $i = 1, 2, \dots, t$. Thus (a) holds.

Without loss of generality, assume that $|X_1| \geq |X_2| \geq \dots \geq |X_t|$ and that W has been chosen so that $|X_1|$ is as large as possible. Let ε_v denote the number of sets X_i containing the vertex $v \in V(G)$, and let $k = \sum_{v \in V(G)} (\varepsilon_v - 1)$. Since $\gamma(G) \leq |X|$,

$$|X| + k = \gamma(G) + t - 2 \text{ and } 0 \leq k \leq t - 2. \tag{3.13}$$

Also, no vertex occurs in all t sets X_i , i.e.

$$X_1 \cap X_2 \cap \dots \cap X_t = \emptyset. \tag{3.14}$$

The following statement is proved next:

$$\text{Each vertex in } X_i, i \geq 2, \text{ is adjacent to some vertex in } Y. \quad (3.15)$$

Suppose there exists $x \in X_i$ that is not adjacent to any vertex in Y , and w_i is a vertex of W_i such that $p(w_i) = x$. Then $w_i \succ p^{-1}(x)$. If $x \in X_1$ and w_1 is a vertex of W_1 such that $p(w_1) = x$, then $W - \{w_1\}$ is a dominating set of $G \square K_t$ of cardinality less than $|W|$, which contradicts the minimality of W . Thus $x \notin X_1$. But then

$$W' = (W_1 \cup \{w_i\}) \cup W_2 \cup \dots \cup W_{i-1} \cup (W_i - \{w_i\}) \cup W_{i+1} \cup \dots \cup W_t$$

is a minimum dominating set of $G \square K_t$ such that $X'_1 = p(W_1 \cup \{w_2\}) = X_1 \cup \{x\}$ has larger cardinality than X_1 , contradicting the choice of W . Thus (3.15) holds.

(b) Suppose two distinct vertices $u, v \in X_i$ are both adjacent to some vertex $y \in Y$. By (a), y is adjacent to a vertex w_i in each X_i . Let $I = \{i : u \in X_i \text{ or } v \in X_i\}$, in other words the set of indices corresponding to sets X_i containing one or more of u, v , and note that $|I| \leq \varepsilon_u + \varepsilon_v - 1$. Also, let $J = \{1, 2, \dots, t\} - I$ and consider the vertices in $\{w_j : j \in J\}$. It follows that the number of distinct vertices w_j in $\{w_j : j \in J\}$ is at least

$$|J| - (k - (\varepsilon_u - 1) - (\varepsilon_v - 1)) \geq |J| - (k - |I| + 1) = t - k - 1.$$

So there exists a subset of indices $J' \subseteq J$ such that $|J'| \geq t - k - 1$, w_j is adjacent to y for every $j \in J'$ and the vertices $\{w_j : j \in J'\}$ are distinct. For any index $j' \in J'$, $X_{j'} \succ Y$, so that $(X - \{u, v, w_j : j \in J' - \{j'\}\}) \cup \{y\}$ is a dominating set of G that has cardinality at most $\gamma(G) - 1$, a contradiction. Hence each vertex $y \in Y$ is dominated by exactly one vertex from X_i , and (b) follows.

(c) Suppose that for some $\{i, j\} \subset \{1, 2, \dots, t\}$ and some vertex $z \in V(G)$, $z \in X_i \cap X_j$.

Denote the i^{th} G -layer of $G \square K_t$ by V_i and let ϕ denote the mapping from this Cartesian product to $G \square K_{t-1}$ obtained by identifying the corresponding vertices in V_i and V_j . Then the set $\phi(W) = \{\phi(W_k) : k \neq i, j\} \cup \phi(W_i \cup W_j)$ is a dominating set of $G \square K_{t-1}$ of cardinality at most $|W| - 1 = \gamma(G) + (t - 1) - 2$, so that G is a Cartesian $(t - 1)$ -fixer – a contradiction. It follows that $X_1 \cap X_2 \cdots \cap X_t = \emptyset$ (in other words $k = 0$) and therefore $|X| = \sum_{i=1}^t |X_i| = \gamma(G) + t - 2$, implying that the sets X_i are disjoint.

(d) Suppose that $|X_2| \geq 2$. Then $|X_1| \geq 2$. Let $y_1 \in Y$ and choose $x_i \in X_i$, $i = 1, 2, \dots, t$, such that x_i is adjacent to y_1 for every i . Since $X_t \succ Y$, the set $X' = (X - \{x_i : i = 1, 2, \dots, t - 1\}) \cup \{y_1\}$ is a dominating set of G of cardinality $\gamma(G)$, i.e. a γ -set of G . It is shown next that

$$\{x_1, x_2\} \succ Y. \tag{3.16}$$

Suppose to the contrary that $y \in Y$ is adjacent to neither x_1 nor x_2 . Then there exist $x'_1 \in X_1 - \{x_1\}$ and $x'_2 \in X_2 - \{x_2\}$ adjacent to y , so that $(X' - \{x'_1, x'_2\}) \cup \{y\}$ is a dominating set of G of cardinality $\gamma(G) - 1$, which is impossible.

Let $v \in X_2 - \{x_2\}$. By (3.15) there exists a vertex $y_2 \in Y$ adjacent to v . By (b) y_2 is not adjacent to x_2 and so, by (3.16), y_2 is adjacent to x_1 . It follows similar to (3.16) that $\{x_1, v\} \succ Y$. But then any vertex in Y not adjacent to x_1 is adjacent to both x_2 and v , which is impossible by (b). Thus $x_1 \succ Y$, and (b) implies that $|X_1| = 1$, a contradiction. Therefore $|X_2| = 1$ which, by the choice of the X_i , also implies that $|X_i| = 1$ for each $i \geq 3$.

Conversely, let G be a graph that satisfies the conditions of the statement and $V(K_n) = \{u_1, u_2, \dots, u_n\}$. Since G does not have a symmetric γ -set, G is not a 2-fixer. If $3 \leq s < t$ is the smallest integer such that G is an s -fixer, then by the above argument, t is not the smallest integer satisfying the conditions of the statement, a contradiction. Suppose that G has a set $X = X_1 \cup X_2 \cup \dots \cup X_t$ with the stated properties. Let $X_i = \{x_i\}$ for

$i = 2, 3, \dots, t$. Then the set

$$W = \{(v, u_1) : v \in X_1\} \cup \{(x_i, u_i) : i = 2, 3, \dots, t-1\} \cup \{(x_t, u_i) : i = t, t+1, \dots, n\}$$

is a dominating set of $G \square K_n$ of cardinality $\gamma(G) + n - 2$, and therefore G is an n -fixer for $n \geq t$. ■

3.3 Cartesian Multipliers

In 2004, Burger, Mynhardt and Weakley [5] characterized *prism doublers*, i.e. graphs G for which $\gamma(G \square K_2) = 2\gamma(G)$. In general $\gamma(G \square K_n) \leq n\gamma(G)$ for any $n \geq 2$, and a graph attaining equality in this upper bound is called a *Cartesian n -multiplier*. Once again, such graphs are simply referred to as *n -multipliers*. The argument in [5] is generalized below to characterize n -multipliers.

Consider n such that $\gamma(G) + n - 2 < |V(G)|$ and recall that $\gamma(G) + n - 2 \leq \gamma(G \square K_n) \leq n\gamma(G)$. Observe that, for any $0 \leq i \leq (\gamma(G) - 1)(n - 1) + 1$, there exist graphs G such that $\gamma(G \square K_n) = \gamma(G) + n - 2 + i$. (The upper bound on i ensures that $\gamma(G) + n - 2 + i \leq n\gamma(G)$.) Consider the complete bipartite graph $G = K_{l,k}$ with $l \leq k$ and let x_1, x_2, \dots, x_l be the vertices in the smaller partite set. With notation as in Theorem 3.2.4(ii), let $X_i = \{x_i\}$ and $X = \{x_1, x_2, \dots, x_l\}$. If $l = 2$, then X is a primitive symmetric γ -set of G , hence G is a consistent fixer by Theorem 3.2.3. If $l = n \geq 3$, then X satisfies the conditions in Theorem 3.2.5, so G is an n -fixer. If $l = n + i$, then $\gamma(G \square K_n) = \gamma(G) + n - 2 + i$, up to values of i for which $\gamma(G \square K_n) = n\gamma(G)$, in which case G is an n -multiplier (or a prism doubler if $n = 2$).

Burger, Mynhardt and Weakley [5] characterized prism doublers as follows.

Proposition 3.3.1 [5] *A graph G is a prism doubler if and only if for each set $X \subseteq V(G)$ with $0 < |X| < \gamma(G)$, and $Y = V(G) - N[X]$, either*

(i) $|Y| \geq 2\gamma(G) - |X|$, or

(ii) $|Y| = 2\gamma(G) - |X| - d$ for some $1 \leq d \leq |X|$, and at least d vertices (necessarily in $N[X]$) are required to dominate $N\{X\} - N[Y]$. ■

In $G \square K_n$, denote the i^{th} G -layer of G by G_i and $V(G_i)$ by V_i . For $S \subseteq V(G)$, let $\langle S \rangle_i$ denote the counterpart of S in G_i (in other words $p(\langle S \rangle_i) = S$). Note that if $|V(G)| < n\gamma(G)$, then G is not an n -multiplier since V_1 is a dominating set of $G \square K_n$. Thus only graphs G of order at least $n\gamma(G)$ are considered. The collection of sets Y_1, Y_2, \dots, Y_n is called a *covering* of a set Y if $\cup_{i=1}^n Y_i = Y$.

Proposition 3.3.2 *A graph G is an n -multiplier if and only if for each set $X \subseteq V(G)$ with $0 < |X| < \gamma(G)$, and $Y = V(G) - N[X]$, either*

(i) $|Y| \geq n\gamma(G) - |X|$, or

(ii) $|Y| = n\gamma(G) - |X| - d$ for some $1 \leq d \leq (n-1)|X|$, and for any covering Y_2, Y_3, \dots, Y_n of Y , the subgraph of $G \square K_n$ induced by $\cup_{i=2}^n \langle N\{X\} - N[Y_i] \rangle_i$ has domination number at least d .

Proof: Suppose G is an n -multiplier and consider any set $X \subseteq V(G)$, where $0 < |X| < \gamma(G)$, and $Y = V(G) - N[X]$.

If $|Y| \geq n\gamma(G) - |X|$, then (i) holds. If $|Y| < n\gamma(G) - n|X|$, then $(\cup_{i=1}^n \langle X \rangle_i) \cup \langle Y \rangle_1$ is a dominating set of $G \square K_n$ of cardinality $n|X| + |Y| < n\gamma(G)$ - a contradiction.

Hence assume that $|Y| = n\gamma(G) - |X| - d$ for some $1 \leq d \leq (n-1)|X|$. Suppose there exists a covering Y_2, Y_3, \dots, Y_n of Y such that the subgraph of $G \square K_n$ induced by $\cup_{i=2}^n \langle N\{X\} -$

$N[Y_i]_i$ is dominated by some set D of cardinality less than d . Then $\langle X \rangle_1 \cup (\bigcup_{i=2}^n \langle Y_i \rangle_i) \cup D$ is a dominating set of $G \square K_n$ of cardinality less than $|X| + |Y| + d = n\gamma(G)$ – a contradiction.

Conversely, suppose that $\gamma(G \square K_n) < n\gamma(G)$, and consider any minimum dominating set $D = D_1 \cup D_2 \cup \dots \cup D_n$ of $G \square K_n$. Let $B_i = p(D_i)$, $i = 1, 2, \dots, n$. Then $|B_i| < \gamma(G)$ for some i ; without loss of generality assume $|B_1| < \gamma(G)$. Then $|B_1| > 0$, otherwise at least $|V(G)|$ vertices are needed to dominate G_1 in $G \square K_n$. But then $|V(G)| \leq |D| < n\gamma(G)$ and these graphs are not considered. Thus $0 < |B_1| < \gamma(G)$. It is shown that neither (i) nor (ii) holds for the set $X = B_1$.

Let $B = B_1 \cup B_2 \cup \dots \cup B_n$ and $Y = V(G) - N[B_1]$. In the layer G_1 , $V_1 - N[D_1]$ is dominated by $D_2 \cup D_3 \cup \dots \cup D_n$. Therefore in G , $Y \subseteq \bigcup_{i=2}^n B_i$ and so $|Y| \leq |B| - |B_1| < n\gamma(G) - |B_1|$. Thus (i) does not hold. If $|Y| < n\gamma(G) - n|B_1|$, then (ii) does not hold either. Hence assume that $|Y| = n\gamma(G) - |B_1| - d$ for some $1 \leq d \leq (n-1)|B_1|$.

Let Y_2, Y_3, \dots, Y_n be a covering of Y such that $Y_i \subseteq B_i$, $i = 2, 3, \dots, n$, and let $Z_i = B_i - Y_i$. Then the set $D' = \bigcup_{i=2}^n \langle Z_i \rangle_i$ dominates the subgraph of $G \square K_n$ induced by $\bigcup_{i=2}^n \langle N\{B_1\} - N[Y_i] \rangle_i$. But

$$|D'| \leq \sum_{i=2}^n |B_i| - \sum_{i=2}^n |Y_i| < n\gamma(G) - |B_1| - |Y| = d.$$

Therefore (ii) does not hold. ■

A family of multipliers with domination number 2 is constructed next. Let $n \geq 2$ and consider disjoint complete graphs K_{n+1} and K_{2n} , with vertex sets $A = \{v_1, v_2, \dots, v_{n+1}\}$ and $B = \{w_1, w_2, \dots, w_{2n}\}$, respectively. Let G_n be the graph obtained by adding the edges $v_i w_i$, $i = 1, \dots, n+1$. Proposition 3.3.2 is used to show that G_n is an n -multiplier. Since $\gamma(G) = 2$, only sets X of cardinality 1 need to be considered. There are three possibilities for X .

- If $X = \{v_i\}$, then $Y = B - \{w_i\}$ and $|Y| = 2n - 1 = n\gamma(G_n) - |X|$.
- If $X = \{w_i\}$ with $i \leq n + 1$, then $Y = A - \{v_i\}$ and $|Y| = n = n\gamma(G_n) - |X| - d$ with $d = n - 1$. For any $Y' \subseteq Y$, $N(w_i) - N[Y']$ contains the vertices w_{n+2}, \dots, w_{2n} . Thus, for any covering Y_2, Y_3, \dots, Y_n of Y , the subgraph of $G_n \square K_n$ induced by $\bigcup_{i=2}^n \langle N(w_i) - N[Y_i] \rangle_i$ has a subgraph isomorphic to $K_{n-1} \square K_{n-1}$, which has domination number $d = n - 1$. Hence Proposition 3.3.2(ii) holds.
- If $X = \{w_i\}$, $i > n + 1$, a similar argument shows that Proposition 3.3.2(ii) also holds.

It follows that G is an n -multiplier.

3.4 Universal Multipliers

Burger, Mynhardt and Weakley [5] investigated the domination of generalized prisms, noting that for any graph G and permutation π , $\gamma(G) \leq \gamma(\pi G) \leq 2\gamma(G)$. They characterized graphs for which $\gamma(\pi G) = 2\gamma(G)$ for any π , calling such graphs *universal doublers*.

Proposition 3.4.1 [5] *A graph G is a universal doubler if and only if for each $X \subseteq V(G)$ with $0 < |X| < \gamma(G)$, $|V(G) - N[X]| \geq 2\gamma(G) - |X|$. ■*

It is clear that $\gamma(G) \leq \gamma(G \boxtimes K_n) \leq n\gamma(G)$ for any permutation π . The lower bound is satisfied for all π and n when $G = \overline{K_m}$, while the upper bound is satisfied for all π and $n \leq |V(G)|$ if $G = K_m$. Graphs G that satisfy $\gamma(G \boxtimes K_n) = n\gamma(G)$ for all π are called *universal n -multipliers*. For $n = 2$, Proposition 3.4.1 confirms that there are noncomplete graphs that are universal 2-multipliers (i.e. universal doublers). Examples of universal n -multipliers are provided and this class of graphs is characterized below.

A universal 2-multiplier is not necessarily a universal n -multiplier for $n > 2$. As an example, consider $G = C_6$. Since $\gamma(G) = 2$, $|X| = 1$ for any $X \subseteq V(G)$ with $0 < |X| < \gamma(G)$. So $|V(G) - N[X]| = 3$ and it follows from Proposition 3.4.1 that C_6 is a universal 2-multiplier. However, C_6 is not a universal 3-multiplier. Figure 3.6 shows the generalized Cartesian product $C_6 \boxtimes K_3$, $\pi = (v_4, v_6)$, with a dominating set of cardinality 5 indicated by dark vertices.

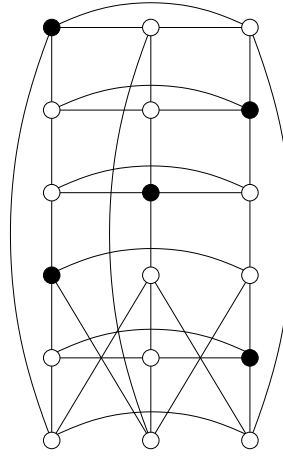


Figure 3.6: $C_6 \boxtimes K_3$, with $\pi = (v_4, v_6)$.

As mentioned above, K_m ($m \geq 2$) is a universal n -multiplier for any $2 \leq n \leq m$, since $\gamma(K_m \boxtimes K_n) = \min\{m, n\}$. In fact, any m -vertex graph G with $\gamma(G) = 1$ is a universal n -multiplier, since $G \boxtimes K_n$ is a spanning subgraph of $K_m \boxtimes K_n$.

Suppose that G is not a universal n -multiplier. Then there exists a permutation π such that $G \boxtimes K_n$ has a dominating set X of cardinality less than $n\gamma(G)$. In the graph $G \boxtimes K_{n+1}$, the first n G -layers induce a subgraph isomorphic to $G \boxtimes K_n$. The union of the set X in this subgraph with a γ -set of G in the last G -layer is then a dominating set of $G \boxtimes K_{n+1}$ of cardinality less than $(n + 1)\gamma(G)$. This motivates the following observation.

Observation 3.4.1 *If G is not a universal n -multiplier, then it is not a universal $(n + 1)$ -multiplier, $n \geq 2$.* ■

A family of universal multipliers is constructed next. Let $2k \geq l \geq 2$ and consider l copies of the star $K_{1,2k}$. Let v_i be the centre and $V_i = \{w_{i,1}, w_{i,2}, \dots, w_{i,2k}\}$ the set of leaves of the i^{th} copy of $K_{1,2k}$, $i = 1, 2, \dots, l$. Let $U_i = \{w_{i,1}, w_{i,2}, \dots, w_{i,k}\}$ and $W_i = \{w_{i,k+1}, w_{i,k+2}, \dots, w_{i,2k}\}$, $i = 1, 2, \dots, l$.

Form the graph $H_{l,2k}$ by joining U_i to W_{i+1} by a matching, $i = 1, 2, \dots, l$, where addition on the subscripts is performed modulo l . Figure 3.7 illustrates the graphs $H_{2,4}$ and $H_{3,4}$. The graphs $H_{l,2k}$ that are universal n -multipliers are characterized in Proposition 3.4.2.

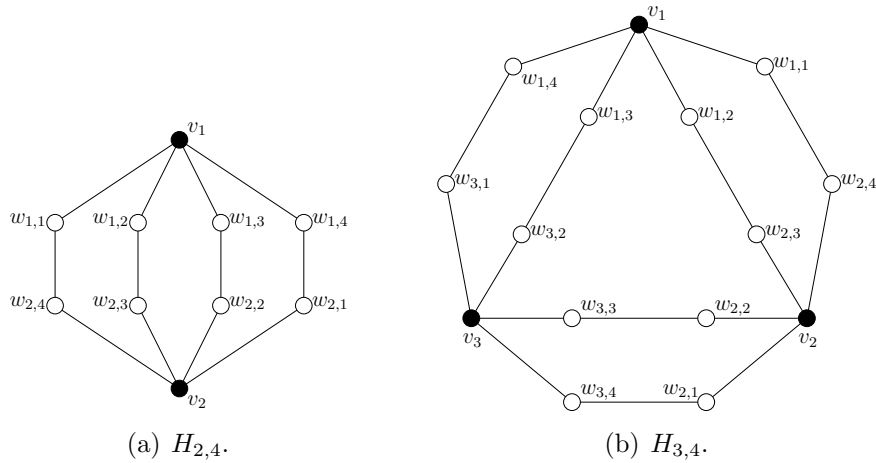


Figure 3.7: Universal 2-multipliers $H_{2,4}$ and $H_{3,4}$.

More generally, for a class of universal 2-multipliers, add arbitrary edges (possibly none) between V_i and V_j , $i \neq j$, $i, j = 1, 2, \dots, l$, subject to the maximum degree being $2k$, and denote the class of all graphs thus constructed by $\mathcal{G}_{l,k}$. Any graph $G \in \mathcal{G}_{l,k}$ has the set $S = \{v_i : i = 1, 2, \dots, l\}$ as an efficient dominating set and therefore $\gamma(G) = l$. (A dominating set D of a graph G is called *efficient* if $N(v) \cap N(w) = \emptyset$ for any $v, w \in D$. Such a set is also a 2-packing of G , and since $\rho_2(G) \leq \gamma(G)$, also a minimum dominating set of G .)

For any $G \in \mathcal{G}_{l,k}$, any integer t with $0 < t < l$, and any $X \subseteq V(G)$ with $|X| = t$,

$$\begin{aligned} |V(G) - N[X]| &\geq |V(G)| - \sum_{x \in X} (\deg x + 1) \geq |V(G)| - (\Delta(G) + 1)t \\ &= (2k + 1)(l - t) \geq (l + 1)(l - t) \quad \text{since } 2k \geq l \\ &\geq 2l - t. \end{aligned}$$

Since $\gamma(G) = l$, it follows from Proposition 3.4.1 that G is a universal 2-multiplier.

Proposition 3.4.2 *The graph $H_{2,2k}$ is a universal n -multiplier ($n \geq 2$) if and only if $k \geq n - 1$.*

Proof: First suppose that $(n - 1)/2 \leq k \leq n - 2$. To show that $H_{2,2k}$ is not a universal n -multiplier, define a permutation π of $V(H_{2,2k})$ such that $\gamma(H_{2,2k} \boxtimes K_n) < n\gamma(H_{2,2k}) = 2n$.

Let $\pi = (v_1, w_{2,1}, w_{2,2}, \dots, w_{2,n-1})$, $V(K_n) = \{u_1, u_2, \dots, u_n\}$ and $V(H_{2,2k} \boxtimes K_n) = \{(v, u) : v \in V(H_{2,2k}), u \in V(K_n)\}$. Define the set $D \subseteq V(H_{2,2k} \boxtimes K_n)$ by

$$D = \{(v_1, u_i) : i = 1, 2, \dots, n\} \cup \{(v_2, u_1)\} \cup \{(w_{2,j}, u_1) : j \geq n\}.$$

Then

- (i) $(v_1, u_i) \succ \{(v_1, u_i)\} \cup \{(w_{1,j}, u_i) : j = 1, 2, \dots, 2k\}$ for each $i = 1, 2, \dots, n$;
- (ii) $(v_2, u_1) \succ (v_2, u_i)$ for each $i = 1, 2, \dots, n$, since $\pi(v_2) = v_2$ implies that $\{(v_2, u_i) : i = 1, 2, \dots, n\}$ is complete;
- (iii) $(w_{2,j}, u_1) \succ (w_{2,j}, u_i)$ for each $j \geq n$ and $i = 1, 2, \dots, n$, since $\pi(w_{2,j}) = w_{2,j}$ if $j \geq n$, which implies that $\{(w_{2,j}, u_i) : i = 1, 2, \dots, n\}$ is complete.

Further, π ensures that each of the following sets induces a K_n -layer in $H_{2,2k} \boxtimes K_n$:

$$\begin{aligned} & \{\underline{(v_1, u_1)}, (w_{2,1}, u_2), (w_{2,2}, u_3), \dots, (w_{2,n-1}, u_n)\}; \\ & \{(w_{2,1}, u_1), (w_{2,2}, u_2), \dots, (w_{2,n-1}, u_{n-1}), \underline{(v_1, u_n)}\}; \\ & \{(w_{2,2}, u_1), (w_{2,3}, u_2), \dots, (w_{2,n-1}, u_{n-2}), \underline{(v_1, u_{n-1})}, (w_{2,1}, u_n)\}; \\ & \quad \vdots \\ & \{(w_{2,n-1}, u_1), \underline{(v_1, u_2)}, (w_{2,1}, u_3), (w_{2,2}, u_4), \dots, (w_{2,n-2}, u_n)\}. \end{aligned}$$

Since each set contains a vertex $(v_1, u_i) \in D$, and each vertex $(w_{2,j}, u_i)$ for $1 \leq j \leq n-1$ is contained in one of the sets,

$$(iv) \quad D \succ \{(w_{2,j}, u_i) : 1 \leq j \leq n-1, 1 \leq i \leq n\}.$$

Therefore, by (i) – (iv), D is a dominating set of $H_{2,2k} \boxtimes K_n$. Moreover,

$$|D| = n + 1 + (2k - n + 1) < 2n = n\gamma(H_{2,2k}),$$

so that $H_{2,2k}$ is not a universal n -multiplier.

For the case $k < (n-1)/2$, a similar proof (with the same permutation π and with $D = \{(v_1, u_i) : i = 1, 2, \dots, n\} \cup \{(v_2, u_1)\}$) shows that $H_{2,2k}$ is not a universal n -multiplier.

Now assume that $k \geq n-1$ and suppose, contrary to the statement of the proposition, that $H_{2,2k}$ is not a universal n -multiplier. Then there exist a permutation π of $V(H_{2,2k})$ and a dominating set $D = D_1 \cup \dots \cup D_n$ of $H_{2,2k} \boxtimes K_n$ of cardinality less than $n\gamma(H_{2,2k}) = 2n$. Let $X_i = p(D_i)$, $i = 1, 2, \dots, n$. Then $|X_i| < 2$ for some i . If $|X_i| = 1$, then

$$|V(H_{2,2k}) - N[X_i]| \geq 4k + 2 - (\Delta(H_{2,2k}) + 1) = 2k + 1 \geq 2n - 1.$$

Therefore at least $2n - 1$ vertices of the first $H_{2,2k}$ -layer are dominated by vertices in $D' = D - D_i$. But each vertex in D' dominates only one vertex in the first $H_{2,2k}$ -layer, and $|D'| < 2n - 1$, a contradiction. If $X_i = \emptyset$, then each of the $4k + 2$ vertices of the first $H_{2,2k}$ -layer is dominated by D' . But in this case $|D'| < 2n \leq 4k + 2$, which is also a contradiction. \blacksquare

A similar argument to the one above works when $l \geq 3$.

Proposition 3.4.3 *The graph $H_{l,2k}$ is a universal n -multiplier ($n \geq 2$) if and only if $k \geq l(n - 1)/2$.*

Proof: First suppose that $(l - 1)(n - 1)/2 \leq k < l(n - 1)/2$. To show that $H_{l,2k}$ is not a universal n -multiplier, define a permutation π of $V(H_{l,2k})$ such that $\gamma(H_{l,2k} \boxtimes K_n) < n\gamma(H_{l,2k}) = ln$, as follows.

Let

$$\pi = \prod_{i=1}^{l-1} (v_i, w_{l,(i-1)(n-1)+1}, \dots, w_{l,i(n-1)}),$$

$V(K_n) = \{u_1, u_2, \dots, u_n\}$ and $V(H_{l,2k} \boxtimes K_n) = \{(v, u) : v \in V(H_{l,2k}), u \in V(K_n)\}$. Define the set $D \subseteq V(H_{l,2k} \boxtimes K_n)$ by

$$D = \{(v_i, u_j) : i = 1, 2, \dots, l-1, j = 1, 2, \dots, n\} \cup \{(v_l, u_1)\} \cup \{(w_{l,i}, u_1) : i > (l-1)(n-1)\}.$$

Then

- (i) $(v_i, u_j) \succ \{(v_i, u_j)\} \cup \{(w_{i,r}, u_j) : r = 1, 2, \dots, 2k\}$ for each $i = 1, 2, \dots, l - 1, j = 1, 2, \dots, n$;
- (ii) $(v_l, u_1) \succ (v_l, u_i)$ for each $i = 1, 2, \dots, n$, since $\pi(v_l) = v_l$ implies that $\{(v_l, u_i) : i = 1, 2, \dots, n\}$ is complete;

(iii) $(w_{l,j}, u_1) \succ (w_{l,j}, u_i)$ for each $j > (l-1)(n-1)$ and $i = 1, 2, \dots, n$, since $\pi(w_{l,j}) = w_{l,j}$ if $j > (l-1)(n-1)$, which implies that $\langle \{(w_{l,j}, u_i) : i = 1, 2, \dots, n\} \rangle$ is complete.

For each $i \in \{1, 2, \dots, l-1\}$, π ensures that each of the following sets induces a K_n -layer in $H_{l,2k} \boxtimes K_n$:

$$\begin{aligned} & \{(\underline{v_1, u_1}), (w_{l,(i-1)(n-1)+1}, u_2), (w_{l,(i-1)(n-1)+2}, u_3), \dots, (w_{l,i(n-1)}, u_n)\}; \\ & \{(w_{l,(i-1)(n-1)+1}, u_1), (w_{l,(i-1)(n-1)+2}, u_2), \dots, (w_{l,i(n-1)}, u_{n-1}), (\underline{v_1, u_n})\}; \\ & \{(w_{l,(i-1)(n-1)+2}, u_1), (w_{l,(i-1)(n-1)+3}, u_2), \dots, (w_{l,i(n-1)}, u_{n-2}), (\underline{v_1, u_{n-1}}), (w_{l,(i-1)(n-1)+1}, u_n)\}; \\ & \quad \vdots \\ & \{(w_{l,i(n-1)}, u_1), (\underline{v_1, u_2}), (w_{l,(i-1)(n-1)+1}, u_3), (w_{l,(i-1)(n-1)+2}, u_4), \dots, (w_{l,(i-1)(n-1)+n-2}, u_n)\}. \end{aligned}$$

Since each set contains a vertex $(v_i, u_j) \in D$, and each vertex $(w_{l,r}, u_j)$ for $(i-1)(n-1) < r \leq i(n-1)$ is contained in one of the sets,

$$(iv) \quad D \succ \{(w_{l,i}, u_j) : 1 \leq i \leq (l-1)(n-1), 1 \leq j \leq n\}.$$

Therefore, by (i) – (iv), D is a dominating set of $H_{l,2k} \boxtimes K_n$. Moreover,

$$|D| = n(l-1) + 1 + (2k - (l-1)(n-1)) < ln = n\gamma(H_{l,2k}),$$

so that $H_{l,2k}$ is not a universal n -multiplier.

For the case $k < (l-1)(n-1)/2$, a similar proof (with the same permutation π and with $D = \{(v_i, u_j) : i = 1, 2, \dots, l-1, j = 1, 2, \dots, n\} \cup \{(v_l, u_1)\}$) shows that $H_{l,2k}$ is not a universal n -multiplier.

Now assume that $k \geq l(n-1)/2$ and suppose, contrary to the statement of the proposition, that $H_{l,2k}$ is not a universal n -multiplier. Then there exist a permutation π of $V(H_{l,2k})$ and a dominating set $D = D_1 \cup \dots \cup D_n$ of $H_{l,2k} \boxtimes K_n$ of cardinality less than $n\gamma(H_{l,2k}) = ln$.

Let $X_i = p(D_i)$, $i = 1, \dots, n$. Then $|X_i| < l$ for some i , say $|X_i| = t < l$. If $t > 0$, then

$$\begin{aligned} |V(G) - N[X_i]| &\geq |V(G)| - \sum_{x \in X_i} (\deg x + 1) \geq |V(G)| - (\Delta(G) + 1)t \\ &= (2k + 1)(l - t) \\ &\geq (ln - l + 1)(l - t) \quad \text{since } 2k \geq l(n - 1) \\ &\geq ln - t \quad \text{since } (l - t)(n - 1) \geq n - 1. \end{aligned}$$

Therefore at least $ln - t$ vertices of the first $H_{l,2k}$ -layer are dominated by vertices in $D' = D - D_i$. But each vertex in D' dominates only one vertex in the first $H_{l,2k}$ -layer, and $|D'| < ln - t$, a contradiction. If $X_i = \emptyset$, then each of the $l(2k + 1)$ vertices of the first $H_{l,2k}$ -layer is dominated by D' . But in this case $|D'| < ln < l(2k + 1)$ (since $l \geq 2$), also a contradiction. ■

A characterization of universal n -multipliers similar Proposition 3.4.1 for generalized prisms is now provided. Observe that for any graph G , the vertex set of any G -layer of $G \boxtimes K_n$ dominates $G \boxtimes K_n$. Therefore, if $|V(G)| < n\gamma(G)$, then $\gamma(G \boxtimes K_n) \leq |V(G)| < n\gamma(G)$, so that G is not a universal n -multiplier. Hence only graphs G of order at least $n\gamma(G)$ are considered.

Theorem 3.4.1 *A graph G of order at least $n\gamma(G)$ is a universal n -multiplier if and only if $|V(G) - N[X]| \geq n\gamma(G) - |X|$ for each $X \subseteq V(G)$ with $0 < |X| < \gamma(G)$.*

Proof: Suppose that there exists a set $X \subseteq V(G)$ with $0 < |X| < \gamma(G)$ such that $|V(G) - N[X]| < n\gamma(G) - |X|$. Let $Y = V(G) - N[X]$ and say $|X| = r$, $|Y| = q$. Then there exists an integer k with $k < n(\gamma(G) - r)$ such that $q = (n - 1)r + k$. (Note that k may be negative.) Let $X = \{v_1, v_2, \dots, v_r\}$, $Y = \{w_1, w_2, \dots, w_q\}$, $V(K_n) = \{u_1, u_2, \dots, u_n\}$ and $V(G \boxtimes K_n) = \{(v, u) : v \in V(G), u \in V(K_n)\}$.

Consider the case $k \geq 0$, and define the permutation π of $V(G)$ by

$$\pi = \prod_{i=1}^r (v_i, w_{(i-1)(n-1)+1}, \dots, w_{i(n-1)})$$

and the set $D = D' \cup D'' \subseteq V(G \boxtimes K_n)$ by

$$D' = \{(v_i, u_j) : i = 1, 2, \dots, r, j = 1, 2, \dots, n\} \text{ and } D'' = \{(w_i, u_n) : i > (n-1)r\}.$$

Then D is a dominating set of $G \boxtimes K_n$: Firstly, in the i^{th} -layer G_i of G , the vertices $(v_1, u_i), \dots, (v_r, u_i)$ correspond to the set X in G and thus dominate all vertices of G_i except those corresponding to Y . Secondly, if $i > (n-1)r$, then π fixes w_i and so (w_i, u_j) , $1 \leq j \leq n-1$, is adjacent in $G \boxtimes K_n$ to (w_i, u_n) . Hence

$$D'' \succ \{(w_i, u_j) : i > (n-1)r, 1 \leq j \leq n\}. \quad (3.17)$$

Thirdly, for each $i = 1, \dots, r$, the permutation π ensures that each of the following sets induces a K_n -layer in $G \boxtimes K_n$:

$$\begin{aligned} & \{(v_i, u_1), (w_{(i-1)(n-1)+1}, u_2), (w_{(i-1)(n-1)+2}, u_3), \dots, (w_{i(n-1)}, u_n)\} \\ & \{(w_{(i-1)(n-1)+1}, u_1), (w_{(i-1)(n-1)+2}, u_2), \dots, (w_{i(n-1)}, u_{n-1}), (v_i, u_n)\} \\ & \quad \vdots \\ & \{(w_{i(n-1)}, u_1), (v_i, u_2), (w_{(i-1)(n-1)+1}, u_3), \dots, (w_{(i(n-1)-1}, u_n)\}. \end{aligned}$$

Since each of these sets contains a vertex (v_i, u_j) ,

$$D' \succ \{(w_i, u_j) : 1 \leq i \leq (n-1)r, 1 \leq j \leq n\}. \quad (3.18)$$

By (3.17) and (3.18), $D \succ p^{-1}(Y)$ and so $D \succ G \boxtimes K_n$. But $|D| = nr + k < n\gamma(G)$ and it follows that G is not a universal n -multiplier. For the case $k < 0$, a similar permutation and dominating set show that G is not a universal n -multiplier.

Conversely, suppose G is not a universal n -multiplier. Let G_n denote the n^{th} G -layer of $G \boxtimes K_n$. Then there exist a permutation π of $V(G)$ and a dominating set $D = D_1 \cup D_2 \cup \dots \cup D_n$ of $G \boxtimes K_n$ of cardinality less than $n\gamma(G)$, hence $|D_i| < \gamma(G)$ for some i . Without loss of generality assume $|D_n| < \gamma(G)$ and let $Y_n = V(G_n) - N_{G_n}[D_n]$. Then D_n does not dominate G_n , so that $Y_n \neq \emptyset$ and Y_n is dominated by $D' = D_1 \cup D_2 \cup \dots \cup D_{n-1}$. But each vertex in D' is adjacent to at most one vertex of Y_n , hence $|D'| \geq |Y_n|$. Clearly, if $D_n = \emptyset$, then $|D| = |D'| \geq |V(G)| \geq n\gamma(G)$, which is not the case. Hence $D_n \neq \emptyset$.

But $G_n \cong G$, so if $X = p(D_n)$, then $0 < |X| < \gamma(G)$ and

$$|V(G) - N[X]| = |Y_n| \leq |D'| = |D| - |D_n| < n\gamma(G) - |X|$$

as required. ■

It is verified briefly that $H_{l,2k}$ is a universal n -multiplier if and only if $k \geq l(n-1)/2$, by way of Theorem 3.4.1. Suppose $k < l(n-1)/2$ and let $X = \{v_1, v_2, \dots, v_{l-1}\}$. Then $|V(G) - N[X]| = 2k + 1 < ln - l + 1 = n\gamma(G) - |X|$ since $l = \gamma(G)$ and $|X| = \gamma(G) - 1$. Conversely, for any integer t with $0 < t < l$, and any $X \subseteq V(G)$ with $|X| = t$,

$$\begin{aligned} |V(G) - N[X]| &\geq |V(G)| - \sum_{x \in X} (\deg x + 1) \\ &\geq |V(G)| - (\Delta(G) + 1)t \\ &= (2k + 1)(l - t) \\ &\geq (ln - l + 1)(l - t) \quad \text{since } 2k \geq l(n - 1) \\ &\geq ln - t \quad \text{since } (l - t)(n - 1) \geq n - 1. \end{aligned}$$

The characterization in Theorem 3.4.1 may be generalized to the following result.

Proposition 3.4.4 *Let t be a positive integer. Then $\gamma(G \boxtimes K_n) \geq n\gamma(G)/t$ for any permutation π of $V(G)$ if and only if $|V(G) - N[X]| \geq n\gamma(G)/t - |X|$ for each $X \subseteq V(G)$ with $0 < |X| < \gamma(G)/t$.*

Proof: First consider $t \geq \gamma(G)$. In this case, it is necessary to show that $\gamma(G \boxtimes K_n) \geq n\gamma(G)/t$ for any permutation π of $V(G)$ if and only if $|V(G)| \geq n\gamma(G)/t$. Let $m = n\gamma(G)/t$ and suppose that $|V(G)| = k \geq m$. Then $m \leq n$. Since $\gamma(K_k \boxtimes K_n) = \min\{k, n\} \geq m$ and $G \boxtimes K_n$ is a spanning subgraph of $K_k \boxtimes K_n$, it follows that $\gamma(G \boxtimes K_n) \geq m$. Conversely, if $|V(G)| < m$, then $\gamma(G \boxtimes K_n) \leq |V(G)| < m$.

Assume $1 \leq t < \gamma(G)$ and note that it is only necessary to consider graphs G of order at least $n\gamma(G)/t$. Suppose that there exists a set $X \subseteq V(G)$ with $0 < |X| < \gamma(G)/t$ such that $|V(G) - N[X]| < n\gamma(G)/t - |X|$. Let $Y = V(G) - N[X]$ and say $|X| = r$, $|Y| = q$. Then there exists an integer k with $k < n(\gamma(G)/t - r)$ such that $q = (n-1)r + k$. (Note that k may be negative.) Let $X = \{v_1, v_2, \dots, v_r\}$, $Y = \{w_1, w_2, \dots, w_q\}$, $V(K_n) = \{u_1, u_2, \dots, u_n\}$ and $V(G \boxtimes K_n) = \{(v, u) : v \in V(G), u \in V(K_n)\}$.

Consider the case $k \geq 0$. Define the permutation π of $V(G)$ by

$$\pi = \prod_{i=1}^r (v_i, w_{(i-1)(n-1)+1}, \dots, w_{i(n-1)})$$

and the set $D = D' \cup D'' \subseteq V(G \boxtimes K_n)$ by

$$D' = \{(v_i, u_j) : i = 1, 2, \dots, r, j = 1, 2, \dots, n\} \text{ and } D'' = \{(w_i, u_n) : i > (n-1)r\}.$$

Then D is a dominating set of $G \boxtimes K_n$: Firstly, in the i^{th} -layer G_i of G , the vertices $(v_1, u_i), \dots, (v_r, u_i)$ correspond to the set X in G and thus dominate all vertices of G_i except those corresponding to Y . Secondly, if $i > (n-1)r$, then π fixes w_i and so (w_i, u_j) ,

$1 \leq j \leq n-1$, is adjacent in $G \boxtimes K_n$ to (w_i, u_n) . Hence

$$D'' \succ \{(w_i, u_j) : i > (n-1)r, 1 \leq j \leq n\}. \quad (3.19)$$

Thirdly, for each $i = 1, 2, \dots, r$, the permutation π ensures that each of the following sets induces a K_n -layer in $G \boxtimes K_n$:

$$\begin{aligned} & \{(v_i, u_1), (w_{(i-1)(n-1)+1}, u_2), (w_{(i-1)(n-1)+2}, u_3), \dots, (w_{i(n-1)}, u_n)\} \\ & \{(w_{(i-1)(n-1)+1}, u_1), (w_{(i-1)(n-1)+2}, u_2), \dots, (w_{i(n-1)}, u_{n-1}), (v_i, u_n)\} \\ & \quad \vdots \\ & \{(w_{i(n-1)}, u_1), (v_i, u_2), (w_{(i-1)(n-1)+1}, u_3), \dots, (w_{(i(n-1)-1}, u_n)\}. \end{aligned}$$

Since each of these sets contains a vertex (v_i, u_j) ,

$$D' \succ \{(w_i, u_j) : 1 \leq i \leq (n-1)r, 1 \leq j \leq n\}. \quad (3.20)$$

By (3.19) and (3.20), $D \succ p^{-1}(Y)$ and so $D \succ G \boxtimes K_n$. But $|D| = nr + k < n\gamma(G)/t$ and it follows that $\gamma(G \boxtimes K_n) < n\gamma(G)/t$. For the case $k < 0$, a similar permutation and dominating set show that $\gamma(G \boxtimes K_n) < n\gamma(G)/t$.

Conversely, suppose $\gamma(G \boxtimes K_n) < n\gamma(G)/t$ for some permutation π . Let G_n denote the n^{th} G -layer of $G \boxtimes K_n$ and $D = D_1 \cup D_2 \cup \dots \cup D_n$ a dominating set of $G \boxtimes K_n$ of cardinality less than $n\gamma(G)/t$. Then $|D_i| < \gamma(G)/t$ for some i . Without loss of generality assume $|D_n| < \gamma(G)/t$ and let $Y_n = V(G_n) - N_{G_n}[D_n]$. Then D_n does not dominate G_n , so that $Y_n \neq \emptyset$, and Y_n is dominated by $D' = D_1 \cup D_2 \cup \dots \cup D_{n-1}$. But each vertex in D' is adjacent to at most one vertex of Y_n , hence $|D'| \geq |Y_n|$. Clearly, if $D_n = \emptyset$, then $|D| = |D'| \geq |V(G)| \geq n\gamma(G)/t$, which is not the case. Hence $D_n \neq \emptyset$.

But $G_n \cong G$, if $X = p(D_n)$ (the subset of G corresponding to D_n), then $0 < |X| < \gamma(G)/t$ and

$$|V(G) - N[X]| = |Y_n| \leq |D'| = |D| - |D_n| < n\gamma(G)/t - |X|$$

as required. ■

A similar argument yields the following condition for a graph G to have $\gamma(G \boxtimes K_n) = n\gamma(G)/t$ for some π , $1 \leq t < \gamma(G)$.

Corollary 3.4.1 *Let G be a graph of order at least $n\gamma(G)/t$, $1 \leq t < \gamma(G)$, such that $\gamma(G \boxtimes K_n) \geq n\gamma(G)/t$ for any permutation π of $V(G)$. If there exists an $X \subseteq V(G)$, $0 < |X| < \gamma(G)/t$, such that $|V(G) - N[X]| = n\gamma(G)/t - |X|$, then $\gamma(G \boxtimes K_n) = n\gamma(G)/t$ for some π .*

Proof: Let $Y = V(G) - N[X]$ and say $|X| = r$, $|Y| = q$. Write $q = (n-1)r + k$, where $k = n(\gamma(G)/t - r)$. Let $X = \{v_1, v_2, \dots, v_r\}$, $Y = \{w_1, w_2, \dots, w_q\}$, $V(K_n) = \{u_1, u_2, \dots, u_n\}$ and $V(G \boxtimes K_n) = \{(v, u) : v \in V(G), u \in V(K_n)\}$. Define the permutation π of $V(G)$ by

$$\pi = \prod_{i=1}^r (v_i, w_{(i-1)(n-1)+1}, \dots, w_{i(n-1)})$$

and the set $D = D' \cup D'' \subseteq V(G \boxtimes K_n)$ by

$$D' = \{(v_i, u_j) : i = 1, 2, \dots, r, j = 1, 2, \dots, n\} \text{ and } D'' = \{(w_i, u_n) : i > (n-1)r\}.$$

Then D is a dominating set of $G \boxtimes K_n$: Firstly, in the i^{th} -layer G_i of G , the vertices $(v_1, u_i), \dots, (v_r, u_i)$ correspond to the set X in G and thus dominate all vertices of G_i except those corresponding to Y . Secondly, if $i > (n-1)r$, then π fixes w_i and so (w_i, u_j) ,

$1 \leq j \leq n - 1$, is adjacent in $G \boxtimes K_n$ to (w_i, u_n) . Hence

$$D'' \succ \{(w_i, u_j) : i > (n - 1)r, 1 \leq j \leq n\}. \quad (3.21)$$

Thirdly, for each $i = 1, 2, \dots, r$, the permutation π ensures that each of the following sets induces a K_n -layer in $G \boxtimes K_n$:

$$\begin{aligned} & \{(v_i, u_1), (w_{(i-1)(n-1)+1}, u_2), (w_{(i-1)(n-1)+2}, u_3), \dots, (w_{i(n-1)}, u_n)\} \\ & \{(w_{(i-1)(n-1)+1}, u_1), (w_{(i-1)(n-1)+2}, u_2), \dots, (w_{i(n-1)}, u_{n-1}), (v_i, u_n)\} \\ & \quad \vdots \\ & \{(w_{i(n-1)}, u_1), (v_i, u_2), (w_{(i-1)(n-1)+1}, u_3), \dots, (w_{(i(n-1)-1}, u_n)\}. \end{aligned}$$

Since each of these sets contains a vertex (v_i, u_j) ,

$$D' \succ \{(w_i, u_j) : 1 \leq i \leq (n - 1)r, 1 \leq j \leq n\}. \quad (3.22)$$

By (3.21) and (3.22), $D \succ p^{-1}(Y)$ and so $D \succ G \boxtimes K_n$. Since $|D| = nr + k = n\gamma(G)/t$ it follows that $\gamma(G \boxtimes K_n) \leq n\gamma(G)/t$. \blacksquare

This section is concluded with some corollaries.

Corollary 3.4.2 *Let G be a graph with $\gamma(G) \geq 2$. If G is a universal n -multiplier, then for any γ -set D and $v \in D$, $|\text{pn}(v, D)| > \gamma(n - 1)$.*

Proof: Let D be a γ -set of G , $v \in D$ and $X = D - \{v\}$. Then $|\text{pn}(v, D)| = |V(G) - N[X]|$. Since G is a universal n -multiplier, $|V(G) - N[X]| \geq n\gamma(G) - (\gamma - 1)$. \blacksquare

Corollary 3.4.3 *Let G be an r -regular graph with $\gamma(G) \leq \frac{|V(G)|+r}{n+r}$, $r \geq 2$. Then G is a universal n -multiplier.*

Proof: Let $X \subseteq V(G)$ with $0 < |X| < \gamma(G)$. Then $|V(G)| \geq n\gamma(G) + r(\gamma(G) - 1) \geq n\gamma(G) + r|X|$. But $|N[X]| \leq (r+1)|X|$, hence $|V(G) - N[X]| \geq n\gamma(G) + r|X| - (r+1)|X| = n\gamma(G) - |X|$. ■

The next result is a generalization of Corollary 4 in [5] and follows from Corollary 3.4.3.

Corollary 3.4.4 *If G is an r -regular graph that has an efficient dominating set and $r \geq (n-1)\gamma(G)$, then G is a universal n -multiplier.*

Proof: Observe that $\gamma(G) \leq \frac{(r+1)\gamma(G)+r}{n+r}$ and that $|V(G)| = (r+1)\gamma(G)$. ■

3.5 Universal Cycle-multipliers

This section considers the generalized Cartesian product $G \boxtimes C_n$. A graph G is called a π - n -cycle-multiplier ($n \geq 3$) if $\gamma(G \boxtimes C_n) = n\gamma(G)$, and a *universal n -cycle-multiplier* if $\gamma(G \boxtimes C_n) = n\gamma(G)$ for every permutation π . Since $G \boxtimes C_n$ is a spanning subgraph of $G \boxtimes K_n$, $\gamma(G \boxtimes C_n) \geq \gamma(G \boxtimes K_n)$ for any π . So every universal n -multiplier is also a universal n -cycle-multiplier. Examples of universal cycle-multipliers are provided, as well as necessary and sufficient conditions to be such a graph. First note that G is not an n -cycle-multiplier for any π if $|V(G)| < 3\gamma(G)$:

Let π be any permutation of $V(G)$, $V(C_n) = \{u_1, u_2, \dots, u_n\}$ (canonically labelled) and let G_i denote the G -layer in $G \boxtimes C_n$ corresponding to u_i . Let

$$Y_1 = \begin{cases} \emptyset & \text{if } n \equiv 0 \pmod{3} \\ \{u_1\} & \text{if } n \equiv 1 \pmod{3} \\ \{u_1, u_2\} & \text{if } n \equiv 2 \pmod{3}. \end{cases}$$

Let Y_2 be a γ -set of $C_n - Y_1$ and X be a γ -set of G . Write $n = 3q + r$, $0 \leq r \leq 2$, and note that $|Y_2| = q$. It is routine to verify that the set $D = \{(v, u) : v \in V(G), u \in Y_2\} \cup \{(v, u) : v \in X, u \in Y_1\}$ is a dominating set of $G \boxtimes C_n$. Moreover, $|D| = q|V(G)| + r\gamma(G) < (3q + r)\gamma(G) = n\gamma(G)$. Hence G is not an n -cycle-multiplier. For the remainder of the section, consider graphs G of order at least $3\gamma(G)$.

Theorem 3.5.1 provides a necessary condition similar to Theorem 3.4.1 in the case of universal multipliers.

Theorem 3.5.1 *Let G be a graph of order at least $3\gamma(G)$. If G is a universal n -cycle-multiplier, then $|V(G) - N[X]| \geq 3\gamma(G) - |X| - 1$ for each $X \subseteq V(G)$ with $0 < |X| < \gamma(G)$.*

Proof: Suppose there exists a set $X \subseteq V(G)$ with $0 < |X| < \gamma(G)$ such that $|V(G) - N[X]| < 3\gamma(G) - |X| - 1$. Let $Y = V(G) - N[X]$ and say $|Y| = q$. Then there exists an integer k with $k < \gamma(G) - |X| - 1$ such that $q = 2\gamma(G) + k$. (Note that k may be negative.) Let Z be a γ -set of G , $Y = \{w_1, w_2, \dots, w_q\}$, and $V(C_n) = \{u_1, u_2, \dots, u_n\}$.

First assume that $k \geq 0$ and partition Z into sets Z_1 and Z_2 such that $Z_1 \cap Y = \emptyset$ and $Z_2 = Z \cap Y$. Let $|Z_2| = r$; without loss of generality say $Z_2 = \{w_1, w_2, \dots, w_r\}$ and $Z_1 = \{v_1, v_2, \dots, v_{\gamma-r}\}$ (if $r < \gamma(G)$). Since $k \geq 0$, $q \geq 2\gamma(G) \geq 2r$. Consider two cases based on the parity of r . In each case, define a permutation π of $V(G)$ and construct a dominating set D of $G \boxtimes C_n$ of cardinality less than $n\gamma(G)$, as shown below. Let

$$\alpha = \prod_{\substack{i=1 \\ i \text{ odd}}}^{r-1} (w_i, w_{i+1}, w_{r+i}, w_{r+i+1}) \text{ and } \beta = \prod_{i=2}^{\gamma-r} (v_i, w_{2r+i}, w_{\gamma+r+i}),$$

$$A = \{(v, u_2) : v \in X\},$$

$$B = \{(w_i, u_2) : i > 2\gamma(G)\} \text{ and}$$

$$C = \{(v, u_i) : v \in Z, 1 \leq i \leq n, i \neq 2\}.$$

Case 1: r is even. Define the permutation π of $V(G)$ by $\pi = \alpha\beta(v_1, w_{2r+1}, w_{\gamma+r+1})$ if $r < \gamma(G)$ and $\pi = \alpha$ if $r = \gamma(G)$, and consider the set $D = A \cup B \cup C$. It is shown that D is a dominating set of $G \boxtimes C_n$.

Firstly, in the i^{th} -layer G_i of G , $i \neq 2$, the set $V(G_i) \cap C$ corresponds to the γ -set Z in G and thus dominates all vertices of G_i . Secondly, in the 2^{nd} -layer G_2 of G , the set A corresponds to the set X in G and thus dominates all vertices of G_2 except those corresponding to Y . Since the set B contains vertices in G_2 corresponding to Y , it remains to verify that the vertices (w_i, u_2) , $1 \leq i \leq 2\gamma(G)$, are dominated by D . However, each of these vertices is adjacent to either a vertex in $V(G_1) \cap C \subseteq D$ or a vertex in $V(G_3) \cap C \subseteq D$. This is illustrated in Figure 3.8 for the cycle $(w_i, w_{i+1}, w_{r+i}, w_{r+i+1})$ in α (and therefore also in π). For the sake of convenience only the first label of each vertex is shown, and the vertices in D are shown as dark vertices.

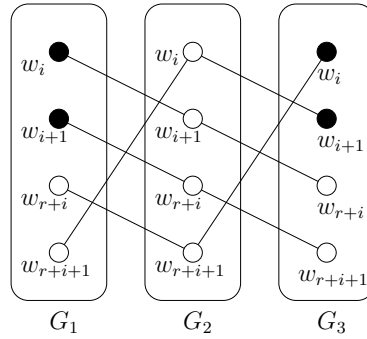


Figure 3.8: Dominating the layer G_2 in $G \boxtimes C_n$. Not all vertices or edges are shown.

Case 2: r is odd. Define the permutation π of $V(G)$ by $\pi = \alpha\beta(v_1, w_r, w_{2r+1}, w_{\gamma+r+1})$ if $r < \gamma(G)$ and $\pi = \alpha$ if $r = \gamma(G)$. Consider the set $D = A \cup B \cup C \cup \{(w_{2r}, u_2)\}$. Firstly, in the i^{th} -layer G_i of G , $i \neq 2$, the set $V(G_i) \cap C$ corresponds to the γ -set Z in G and thus dominate all vertices of G_i . Secondly, in the 2^{nd} -layer G_2 of G , the set A corresponds to the set X in G and thus dominates all vertices of G_2 except those corresponding to Y . Since the set B contains vertices in G_2 corresponding to Y , it remains to verify that the vertices (w_i, u_2) , $1 \leq i \leq 2\gamma(G)$, are dominated by D . With the exception of the vertex

(w_{2r}, u_2) , each of these vertices is adjacent to either a vertex in $V(G_1) \cap C \subseteq D$ or a vertex in $V(G_3) \cap C \subseteq D$. (In the case of $r = \gamma(G)$, $\pi(w_r) = w_r$.) Lastly, $(w_{2r}, u_2) \in D$ and dominates itself.

In each of these cases the set D is a dominating set of $G \boxtimes C_n$ of cardinality at most $|X| + (n - 1)\gamma(G) + k + 1 < n\gamma(G)$. If $k < 0$, a similar permutation and dominating set show that G is not a universal n -cycle-multiplier. ■

The condition in the above theorem is not sufficient for a graph to be a universal n -cycle-multiplier. Consider the circulant graph $G = C_{10}\langle 1, 2 \rangle$ shown in Figure 3.9. Note that $\gamma(G) = 2$, and for each $X \subset V(G)$ of cardinality 1, $|V(G) - N[X]| = 5 > 3\gamma(G) - |X| - 1$. However, as illustrated in Figure 3.10, a 1-3-1-2-1-3-1-2-2-2 domination strategy (that is, 10 consecutive G -layers containing 1, 3, 1, 2, 1, 3, 1, 2, 2, 2 vertices, respectively, of a dominating set) that repeats every 50 G -layers can be used to dominate $G \square C_n$, showing that $\gamma(G \boxtimes C_{50}) \leq 18 \cdot 5 < 50\gamma(G)$ for some π . Therefore $C_{10}\langle 1, 2 \rangle$ is not a universal 50-cycle-multiplier, and there exist graphs G such that for some values of n , G satisfies the condition in Theorem 3.5.1, but is not a universal n -cycle-multiplier.

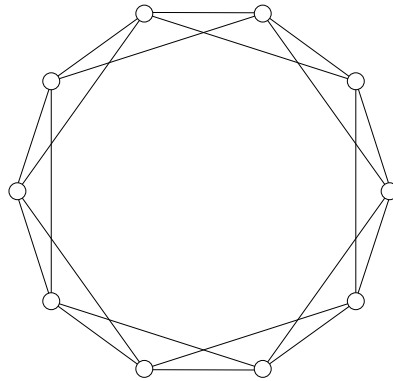


Figure 3.9: The circulant $C_{10}\langle 1, 2 \rangle$.

Again consider the graphs $H_{l,2k}$, as defined in Section 3.4. It was shown that $H_{l,2k}$ is a universal n -multiplier if and only if $k \geq l(n - 1)/2$. These graphs are also universal n -

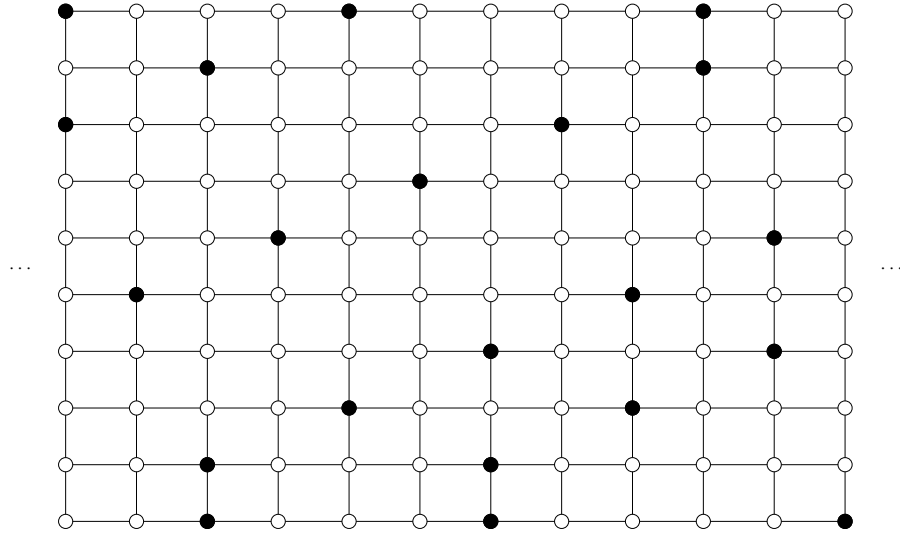


Figure 3.10: A domination strategy for $C_{10}(1, 2) \square C_n$ (not all edges are shown).

cycle-multipliers. However, $H_{l,2k}$ is also a universal n -cycle-multiplier if $k > l$. First, an observation is stated that will be useful for the next proposition. Denote the vertices of $P_m \square C_n$ by $\{v_{i,j} : i = 1, 2, \dots, m, j = 1, 2, \dots, n\}$ for convenience.

Observation 3.5.1 *The minimum cardinality of a dominating set D of $P_3 \square C_n$ such that $v_{2,1}, v_{2,n} \in D$, is at most $\lfloor \frac{3n}{4} \rfloor + 1$. Furthermore, $n > \lfloor \frac{3n}{4} \rfloor + 1$ for $n \geq 5$. ■*

The following proposition provides an infinite family of universal n -cycle-multipliers, $n \geq 4$.

Proposition 3.5.1 *Let $n \geq 4$ and $l \geq 2$. The graph $H_{l,2k}$ is a universal n -cycle-multiplier if and only if $k > l$.*

Proof: Recall that $S = \{v_1, v_2, \dots, v_l\}$ is an efficient dominating set of $H_{l,2k}$ and that $w_{i,1}, w_{i,2}, \dots, w_{i,2k}$ are neighbours of v_i in $H_{l,2k}$, $i = 1, 2, \dots, l$. Also, let $V(C_n) = \{u_1, u_2, \dots, u_n\}$ and $V(H_{l,2k} \square C_n) = \{(v, u) : v \in V(H_{l,2k}), u \in V(C_n)\}$.

Suppose that $k \leq l$. To show that $H_{l,2k}$ is not a universal n -cycle-multiplier, define a permutation π of $V(H_{l,2k})$ such that $\gamma(H_{l,2k} \square C_n) < n\gamma(H_{l,2k}) = ln$.

Case 1: $n \geq 5$. Let

$$\pi = \prod_{i=1}^{k-1} (v_i, w_{l,2i}, w_{l,2i-1})$$

and G' denote the subgraph of $H_{l,2k} \boxtimes C_n$ isomorphic to $P_3 \square C_n$ induced by the vertices $\{(v_l, u_j), (w_{l,2k-1}, u_j), (w_{l,2k}, u_j) : j = 1, 2, \dots, n\}$. Furthermore, let D' be a minimum dominating set of G' that contains the vertices (v_l, u_1) and (v_l, u_n) . Then $|D'| \leq \lfloor \frac{3n}{4} \rfloor + 1 < n$ by Observation 3.5.1. Define the set $D \subseteq V(H_{l,2k} \boxtimes C_n)$ by $D = \{(v_i, u_j) : i = 1, 2, \dots, l-1, j = 1, 2, \dots, n\} \cup D'$. Then

- (i) $(v_a, u_j) \succ \{(w_{a,i}, u_j)\}$ for each $a = 1, 2, \dots, l-1, i = 1, 2, \dots, k$ and $j = 1, 2, \dots, n$;
- (ii) $(v_i, u_j) \succ \{(w_{l,2i}, u_{j+1})\}$ for each $i = 1, 2, \dots, k-1$ and $j = 1, 2, \dots, n-1$;
- (iii) $(v_i, u_{j+1}) \succ \{(w_{l,2i-1}, u_j)\}$ for each $i = 1, 2, \dots, k-1$ and $j = 1, 2, \dots, n-1$;
- (iv) $(v_l, u_1) \succ (w_{l,i}, u_1)$ for each i , since $(v_l, u_1) \in D'$;
- (v) $(v_l, u_n) \succ (w_{l,i}, u_n)$ for each i , since $(v_l, u_n) \in D'$.

The cycle $(v_i, w_{l,2i}, w_{l,2i-1})$ in π is shown in Figure 3.11 to illustrate (ii) and (iii) above. For the sake of convenience only the first label of each vertex is shown, and the vertices in D are shown as dark vertices.

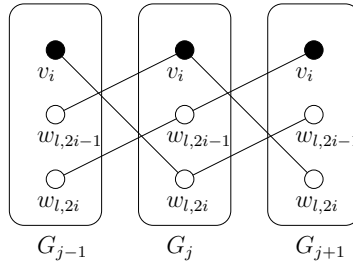


Figure 3.11: A domination strategy of a layer G_j in $H_{l,2k} \boxtimes C_n$, $j \neq 1, n$.

It follows from (i) – (v) that D is a dominating set of $H_{l,2k} \boxtimes C_n$ of cardinality $|D| = n(l-1) + |D'| < n\gamma(H_{l,2k})$, so that $H_{l,2k}$ is not a universal n -cycle-multiplier.

Case 2: $n = 4$. Let

$$\pi = \prod_{i=1}^{k-1} (v_i, w_{l,2i}, w_{1,2i}, w_{l,2i-1})$$

and G' denote the subgraph of $H_{l,2k} \boxtimes C_n$ isomorphic to $P_3 \square C_n$ induced by the vertices $\{(v_l, u_j), (w_{l,k-1}, u_j), (w_{l,k}, u_j) : j = 1, 2, \dots, n\}$. Furthermore, let D' be any minimum dominating set of G' (of cardinality 3) and define the set $D \subseteq V(H_{l,2k} \boxtimes C_n)$ by $D = \{(v_i, u_j) : i = 1, 2, \dots, l-1, j = 1, 2, \dots, n\} \cup D'$. Then

- (i) $(v_i, u_j) \succ \{(w_{l,2i}, u_{j+1})\}$ for each $i = 1, 2, \dots, k-1$ and $j = 1, 2, \dots, n$;
- (ii) $(v_i, u_{j+1}) \succ \{(w_{l,2i-1}, u_j)\}$ for each $i = 1, 2, \dots, k-1$ and $j = 1, 2, \dots, n$.
- (iii) $D' \succ \{(v_l, u_j), (w_{l,k-1}, u_j), (w_{l,k}, u_j) : j = 1, 2, \dots, n\}$.

The cycle $(v_i, w_{l,2i}, w_{1,2i}, w_{l,2i-1})$ in π is shown in Figure 3.12 to illustrate (i) and (ii) above. For the sake of convenience only the first label of each vertex is shown, and the vertices in D are shown as dark vertices.

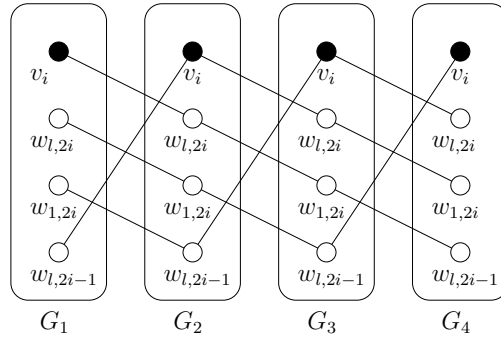


Figure 3.12: A domination strategy of $H_{l,2k} \boxtimes C_n$.

It follows from (i) – (iii) that D is a dominating set of $H_{l,2k} \boxtimes K_n$ of cardinality $|D| = n(l-1) + |D'| < n\gamma(H_{l,2k})$, so that $H_{l,2k}$ is not a universal n -cycle-multiplier, $n = 4$.

Conversely, recall that $l = \gamma(H_{l,2k})$ and suppose $k \geq l + 1$, let $D = D_1 \cup D_2 \cup \dots \cup D_n$ be a γ -set of $H_{l,2k} \boxtimes C_n$. Let $s = (x_1, x_2, \dots, x_n)$, where $x_i = |D_i|$. Then $\gamma(H_{l,2k} \boxtimes C_n) = |D| =$

$\sum_{i=1}^n x_i$. Define a new sequence of rational numbers $s' = (x'_1, x'_2, \dots, x'_n)$ as follows. For each $i \in \{1, 2, \dots, n\}$ with $x_i \geq l + 1$, let $\varepsilon_i = x_i - l$. Decrement x_i by ε_i and increment both x_{i-1} and x_{i+1} by $\frac{\varepsilon_i}{2}$, where addition on the subscripts is performed modulo n . Clearly $\sum_{i=1}^n x'_i = \sum_{i=1}^n x_i = \gamma(H_{l,2k} \boxtimes C_n)$. It is shown that $x'_i \geq l$ for every $i = 1, 2, \dots, n$.

This claim is obvious if $x_i \geq l$. So consider $x_i = l - r$ for some $1 \leq r \leq l$. For any i , exactly x_{i-1} vertices in the i^{th} -layer G_i of G are dominated from G_{i-1} , and exactly x_{i+1} vertices from G_{i+1} . Since the remaining vertices in G_i are dominated from within G_i ,

$$(2k + 1)x_i = (\Delta + 1)x_i \geq |V(H_{l,2k})| - (x_{i-1} + x_{i+1}) = l(2k + 1) - x_{i-1} - x_{i+1}.$$

It follows that $x_{i-1} + x_{i+1} \geq (2k + 1)r$. So $\varepsilon_{i-1} + \varepsilon_{i+1} \geq (2k + 1)r - 2l$. Hence $x'_i \geq x_i + \frac{\varepsilon_{i-1} + \varepsilon_{i+1}}{2} \geq \frac{r}{2}(2k - 1) \geq l$, since $k \geq l + 1$. Therefore, $\gamma(H_{l,2k} \boxtimes C_n) \geq n\gamma(H_{l,2k})$ and $H_{l,2k}$ is a universal n -cycle-multiplier. ■

Similar to Corollary 3.4.2 in the case of universal multipliers, the following necessary condition holds for universal cycle-multipliers.

Corollary 3.5.1 *Let G be a graph with $\gamma(G) \geq 2$ and let $n \geq 5$. If G is a universal n -cycle-multiplier, then $|\text{pn}(v, D)| \geq 2\gamma(G)$ for every γ -set D of G and every $v \in D$.*

Proof: Let D be a γ -set of G , $v \in D$ and $X = D - \{v\}$. Then $|\text{pn}(v, D)| = |V(G) - N[X]|$. Since G is a universal n -cycle-multiplier, $|V(G) - N[X]| \geq 3\gamma(G) - (\gamma(G) - 1) - 1$, and the result follows. ■

The necessary condition in Corollary 3.5.1 is not sufficient. Graphs $F_{l,k}$ similar to the family $\mathcal{G}_{l,k}$ defined in Section 3.4 are constructed next. It is shown that $F_{l,k}$ is not a universal n -cycle-multiplier for some n , but it does have the following property:

(P) For any γ -set D of a graph G and any $v \in D$, $|\text{pn}(v, D)| \geq 2\gamma(G)$.

Let $l \geq 2$, $k \geq 2l + 1$ and consider l copies of the star $K_{1,k}$. Let v_i be the centre and $V_i = \{w_{i,1}, w_{i,2}, \dots, w_{i,k}\}$ the set of leaves of the i^{th} copy of $K_{1,k}$, $i = 1, 2, \dots, l$. Consider the case $l = 2$ separately.

Case 1: $l = 2$. Form the graph $F_{2,k}$ by joining the vertex $w_{1,1}$ to each vertex in the set $\{w_{1,i} : i = 1, 2, \dots, k - 1\} \cup \{w_{2,i} : i = 1, 2, \dots, k - 2\}$. Figure 3.13 illustrates this graph. The graph $F_{2,k}$ has the set $S = \{v_1, v_2\}$ as an efficient dominating set and therefore $\gamma(F_{2,k}) = 2$. This set is also unique, and therefore $F_{2,k}$ satisfies property **P**.

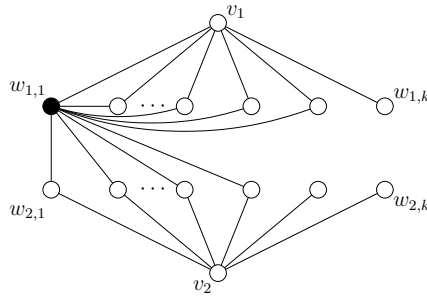


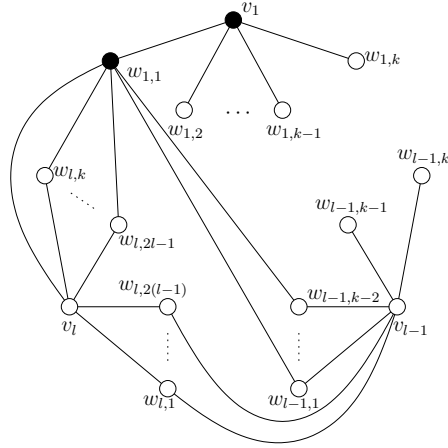
Figure 3.13: The graph $F_{2,k}$.

Case 2: $l \geq 3$. Form the graph $F_{l,k}$ by

- (i) joining the vertex $w_{1,1}$ to each vertex in the set $\{w_{l-1,i} : i = 1, 2, \dots, k - 2\} \cup \{w_{l,i} : i = 2l - 1, 2l, \dots, k\} \cup \{v_l\}$;
- (ii) joining the vertex v_{l-1} to each vertex in the set $\{w_{l,i} : i = 1, 2, \dots, 2(l - 1)\}$;
- (iii) joining vertices $w_{i,k}$ and $w_{i+1,k}$ for $i = 1, 2, \dots, l - 3$.

Figure 3.14 illustrates this graph. The graph $F_{l,k}$ has exactly two distinct efficient dominating sets, namely the set $S_1 = \{v_i : i = 1, 2, \dots, l\}$ and the set $S_2 = (S_1 - \{v_l\}) \cup \{w_{1,1}\}$. Therefore $\gamma(F_{l,k}) = l$, and by the choice of k , the graph satisfies Property **P**.

Proposition 3.5.2 *Let $l \geq 2$ and $k \geq 2l + 1$. The graph $F_{l,k}$ is not a universal n -cycle-multiplier for $n \geq 5$.*


 Figure 3.14: The graph $F_{l,k}$, $l \geq 3$.

Proof: Define a permutation π of $V(F_{l,k})$ and construct a dominating set of $F_{l,k} \boxtimes C_n$ of cardinality less than $n\gamma(F_{l,k}) = ln$ as shown below. Let $V(C_n) = \{u_1, u_2, \dots, u_n\}$, $V(F_{l,k} \boxtimes C_n) = \{(v, u) : v \in V(F_{l,k}), u \in V(C_n)\}$ and consider the case $l = 2$ separately.

Case 1: $l = 2$. Let $\pi = (w_{1,1}, w_{1,k})$ and G' denote the subgraph of $F_{2,k} \boxtimes C_n$ isomorphic to $P_3 \square C_n$ induced by the vertices $\{(v_2, u_j), (w_{2,k-1}, u_j), (w_{2,k}, u_j) : j = 1, 2, \dots, n\}$. Furthermore, let D' be a minimum dominating set of G' . Then $|D'| \leq \lceil \frac{3n}{4} \rceil < n$ for $n \geq 4$. Define the set $D \subseteq V(F_{l,k} \boxtimes C_n)$ by $D = \{(w_{1,1}, u_j) : j = 1, 2, \dots, n\} \cup D'$. Then

- (i) $(w_{1,1}, u_j) \succ (v_1, u_j)$ for each $j = 1, 2, \dots, n$;
- (ii) $(w_{1,1}, u_j) \succ \{(w_{1,i}, u_j)\}$ for each $i = 2, 3, \dots, k-1$ and $j = 1, 2, \dots, n$;
- (iii) $(w_{1,1}, u_j) \succ \{(w_{2,i}, u_j)\}$ for each $i = 2, 3, \dots, k-2$ and $j = 1, 2, \dots, n$;
- (iv) for each $j = 1, 2, \dots, n$, $(w_{1,1}, u_{j-1}) \succ (w_{1,k}, u_j)$ or $(w_{1,1}, u_{j+1}) \succ (w_{1,k}, u_j)$ with addition on the subscript performed modulo n ;
- (v) $D' \succ \{(v_2, u_j), (w_{2,k-1}, u_j), (w_{2,k}, u_j) : j = 1, 2, \dots, n\}$.

Case 2: $l \geq 3$. Let

$$\pi = (w_{1,1}, w_{l,2l-2}, w_{l,2l-3}) \prod_{i=1}^{l-2} (v_i, w_{l,2i}, w_{l,2i-1})$$

and G' denote the subgraph of $F_{2,k} \boxtimes C_n$ isomorphic to $P_3 \square C_n$ induced by the vertices $\{(v_{l-1}, u_j), (w_{l-1,k-1}, u_j), (w_{l-1,k}, u_j) : j = 1, 2, \dots, n\}$. Furthermore, let D' be a minimum dominating set of G' containing the vertices (v_{l-1}, u_1) and (v_{l-1}, u_n) . Then $|D'| \leq \lfloor \frac{3n}{4} \rfloor + 1 < n$ for $n \geq 5$ by Observation 3.5.1. Define the set $D \subseteq V(F_{l,k} \boxtimes C_n)$ by $D = \{(v_i, u_j) : i = 1, 2, \dots, l-2, j = 1, 2, \dots, n\} \cup \{(w_{1,1}, u_j) : j = 1, 2, \dots, n\} \cup D'$. Then

- (i) $(v_i, u_j) \succ \{(w_{l,2i}, u_{j+1})\}$ for each $i = 1, 2, \dots, l-2$ and $j = 1, 2, \dots, n-1$;
- (ii) $(v_i, u_{j+1}) \succ \{(w_{l,2i-1}, u_j)\}$ for each $i = 1, 2, \dots, l-2$ and $j = 1, 2, \dots, n-1$;
- (iii) $(w_{1,1}, u_j) \succ \{(w_{l,2l-2}, u_{j+1})\}$ for each $j = 1, 2, \dots, n-1$;
- (iv) $(w_{1,1}, u_{j+1}) \succ \{(w_{l,2i-3}, u_j)\}$ for each $j = 1, 2, \dots, n-1$;
- (v) $(w_{1,1}, u_j) \succ (w_{l,i}, u_j)$ for each $i \geq 2l-1$ and $j = 1, 2, \dots, n$;
- (vi) $(v_a, u_j) \succ (w_{a,i}, u_j)$ for each $a = 1, 2, \dots, l-2, i = 1, 2, \dots, k$ and $j = 1, 2, \dots, n$;
- (vii) $(v_{l-1}, u_j) \succ (w_{l,i}, u_j)$ for each $i = 1, 2, \dots, 2(l-1)$ and $j = 1, n$;
- (viii) $D' \succ \{(v_{l-1}, u_j), (w_{l-1,k-1}, u_j), (w_{l-1,k}, u_j) : j = 1, 2, \dots, n\}$.

In each case it follows that D is a dominating set of $F_{l,k} \boxtimes C_n$ of cardinality $|D| = n(l-1) + |D'| < n\gamma(F_{l,k})$ for $n \geq 5$, so that $F_{l,k}$ is not a universal n -cycle-multiplier. \blacksquare

For the following observation, once again denote the i^{th} G -layer of G in $G \boxtimes C_n$ by G_i and $V(G_i)$ by V_i . For $S \subseteq V(G)$, let $\langle S \rangle_i$ denote the counterpart of S in G_i .

Observation 3.5.2 *Suppose $X \subseteq V(G)$ with $0 < |X| < \gamma(G)$, $Y = V(G) - N[X]$, and there exists a subgraph G' of $G[Y]$ of order at least $|Y| - 2|X|$ such that, for some permutation α of $V(G')$, $G' \boxtimes C_n$ is dominated by a set D' of cardinality less than $n\gamma(G) - n|X|$ that also dominates $\langle Y \rangle_1$ and $\langle Y \rangle_n$. Then G is not a universal n -cycle-multiplier. ■*

For the circulant $C_{10}\langle 1, 2 \rangle$ shown in Figure 3.9, any set X consisting of one vertex, yields a graph $G[Y]$ that contains a subgraph isomorphic to P_3 . In combination with Observation 3.5.1, Observation 3.5.2 agrees that $C_{10}\langle 1, 2 \rangle$ is not a universal n -cycle-multiplier for large enough values of n .

3.6 Universal Fixers

As mentioned in Section 3.4, $\gamma(G) \leq \gamma(\pi G) \leq 2\gamma(G)$ for the generalized prism πG , and a graph is called a universal fixer if $\gamma(\pi G) = \gamma(G)$ for any permutation π . In general, $\gamma(G) \leq \gamma(G \boxtimes H) \leq \gamma(G)|V(H)|$, and a graph G attaining equality in the lower bound for some permutation π is called a π - H -fixer. If $H = K_n$, the graph G is simply called a π - n -fixer. This section investigates the existence of *universal H -fixers*, i.e. graphs that are π - H -fixers for some H and all permutations π of $V(G)$.

First, observe that if G is a π - H -fixer for some graph H and permutation π , then G is also a π - $(H + e)$ -fixer, for any edge $e \in E(\overline{H})$. The edgeless graph $\overline{K_m}$ is a π - H -fixer for any permutation π and any H such that $\gamma(H) = 1$ (and only for such graphs H). Hence $\overline{K_m}$ is also a π - n -fixer for any π and n . However, if a graph G is not a π - n -fixer for some π and n , then G is not a π - H -fixer for any H of order n , since $G \boxtimes H$ is a spanning subgraph of $G \boxtimes K_n$.

Proposition 3.6.1 *Let $n \geq 3$ and G be a nontrivial connected graph. Then $\gamma(G \boxtimes (K_n - e)) > \gamma(G)$ for any edge $e \in E(K_n)$.*

Proof: Let $H = K_n - e$ and note that $\gamma(G) < |V(G)|$. Let u_1, u_2 be two nonadjacent vertices in H and G_1, G_2 , respectively, be the G -layers corresponding to u_1, u_2 . Suppose $D = D_1 \cup D_2 \cup \dots \cup D_n$ is a γ -set of $G \boxtimes H$ with $|D| = \gamma(G)$. If $D_1 = \emptyset$, then $|D| \geq |V(G)|$ to dominate G_1 , a contradiction. Assume $D_1 \neq \emptyset$. Then G_2 is dominated by (say) α vertices in D_2 and β vertices in $D_3 \cup \dots \cup D_n$, where $\alpha + \beta = |D| - |D_1| < \gamma(G)$. But each vertex in $D_3 \cup \dots \cup D_n$ dominates only one vertex in G_2 , and thus G_2 has a dominating set consisting of the α vertices in D_2 and at most β other vertices in G_2 , so that $\gamma(G_2) \leq \alpha + \beta < \gamma(G)$, also a contradiction. ■

Therefore, for any noncomplete H and permutation π , only the edgeless graphs are π - H -fixers, and clearly only in the case where $\gamma(H) = 1$.

Observation 3.6.1 *There are no nontrivial connected π - H -fixers for any noncomplete H of order $n \geq 3$.* ■

Henceforth only consider the case where H is the complete graph K_n .

Let $n \geq 2$. A family of graphs \mathcal{G}_n that are π - n -fixers for some π is constructed next. Let H be a graph of order n with vertex set $V(H) = \{w_1, w_2, \dots, w_n\}$. Consider the corona $\text{cor}(H)$ of H , with end-vertices v_1, v_2, \dots, v_n . Let G be the graph obtained from $\text{cor}(H)$ by joining the vertex v_1 to every vertex w_i in H , and \mathcal{G}_n denote the family of graphs thus obtained. For $H = K_3$, the graph G is shown in Figure 3.15. Let $G \in \mathcal{G}_n$, $V(K_n) = \{u_1, u_2, \dots, u_n\}$, $\pi = (v_1, v_2, \dots, v_n)$ and define $D = \{(v_1, u_j) : j = 1, 2, \dots, n\}$. Then

- (i) $(v_1, u_j) \succ (w_i, u_j)$ for each $i, j = 1, 2, \dots, n$;
- (ii) for each $i, j = 1, 2, \dots, n$, the vertex (v_i, u_j) is contained in a K_n -layer with (v_1, u_k) for some $k \in \{1, 2, \dots, n\}$, so that $(v_1, u_k) \succ (v_i, u_j)$.

It follows that D is a dominating set of $G \boxtimes K_n$ of cardinality $\gamma(G)$, so that G is a π - n -fixer.

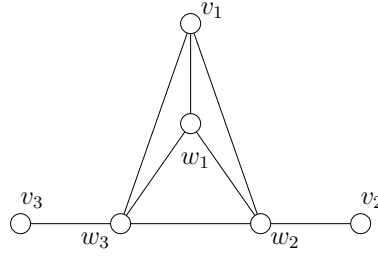


Figure 3.15: The graph $G \in \mathcal{G}_3$.

It is noted that, if $n > \frac{\gamma(G)(|V(G)|-1)}{|V(G)|-\gamma(G)}$, then G is not a π - n -fixer for any permutation π of $V(G)$.

Proposition 3.6.2 *Let $n \geq 2$. If G is a π - n -fixer for some permutation π of $V(G)$, then $\gamma(G) \geq \frac{n|V(G)|}{n+|V(G)|-1}$.*

Proof: Let m denote the order of G , D be a γ -set of $G \boxtimes K_n$ and G be a π - n -fixer. Then $|D| = \gamma(G)$ and each vertex in D dominates at most $n + m - 1$ vertices in $G \boxtimes K_n$. So $mn = |V(G \boxtimes K_n)| \leq (m + n - 1)\gamma(G)$. ■

A graph G is called a *universal n -fixer* if $\gamma(G \boxtimes K_n) = \gamma(G)$ for any permutation π . For the case $n = 2$, Mynhardt and Xu [59] conjectured in 2006 that only the edgeless graphs are universal 2-fixers.

Conjecture 3.6.1 [59] *There are no nontrivial connected universal 2-fixers.* ■

For $\pi \in \text{Aut}(G)$, $G \boxtimes K_n$ is isomorphic to $G \square K_n$. In 2004, Hartnell and Rall [41] characterized graphs G , called prism fixers, for which $\gamma(G \square K_2) = \gamma(G)$. Hartnell and Rall generalized this lower bound to $\gamma(G \square K_n)$, as stated in Theorem 3.2.2 and showed that the lower bound is sharp by providing a family of graphs attaining equality. For $2 \leq n < |V(G)| - \gamma(G) + 2$, a graph G is called a Cartesian n -fixer if $\gamma(G \square K_n) = \gamma(G) + n - 2$.

These graphs are characterized in Section 3.2. From Theorem 3.2.2, it follows that there are no nontrivial universal fixers for $n \geq 3$.

Corollary 3.6.1 *Let $n \geq 3$. If $E(G) \neq \emptyset$, then G is not a universal n -fixer.*

Proof: If $n < |V(G)| - \gamma(G) + 2$, then $\gamma(G \square K_n) \geq \gamma(G) + n - 2 > \gamma(G)$. Otherwise, $\gamma(G \square K_n) \geq |V(G)| > \gamma(G)$, since G has an edge. ■

Proposition 3.6.3 *Let G be a connected, consistent Cartesian fixer of order at least 3 and $\gamma(G) \geq 3$. Then for some n with $3 \leq n < |V(G)| - \gamma(G) + 2$, there exists a permutation π such that $\gamma(G \boxtimes K_n) < \gamma(G \square K_n)$.*

Proof: Consider the two cases stated in Theorem 3.2.3, each time modifying a minimum dominating set of $G \square K_n$ and showing that it is a dominating set of $G \boxtimes K_n$ for some permutation π . Let $V(G \square K_n) = \{(v, u) : v \in V(G), u \in V(K_n)\}$ and $V(K_n) = \{u_1, u_2, \dots, u_n\}$.

Let $3 \leq n < |V(G)| - \gamma(G) + 2$ and suppose G has a symmetric γ -set $D = D_1 \cup D_2$ with $D_2 = \{x\}$ and $D_1 = \{v_1, v_2, \dots, v_k\}$, $k = \gamma(G) - 1$. Then the set $W = \{(v, u_1) : v \in D_1\} \cup \{(x, u_i) : i = 2, 3, \dots, n\}$ is a (minimum) dominating set of $G \square K_n$ of cardinality $\gamma(G) + n - 2$. Note that $n < |V(G)|$ and let $\pi = (x, v_1, v_2, \dots, v_{n-1})$, $Y = V(G) - D$ and define the set $W' = (W \cup \{(x, u_1)\}) - \{(v_i, u_1) : i = 1, 2, \dots, n - 1\}$. Then

- (i) $(x, u_i) \succ Y_i$ for each $i = 1, 2, \dots, n$;
- (ii) $(v_i, u_1) \succ (v_i, u_j)$ for each $i > n - 1$ and $j = 1, 2, \dots, n$, since $\pi(v_i) = v_i$ if $i > n - 1$, which implies that $\langle \{(v_i, u_j) : j = 1, 2, \dots, n\} \rangle$ is complete;
- (iii) for any $i = 1, 2, \dots, n - 1$, $j = 1, 2, \dots, n$, the vertex (v_i, u_j) is in a K_n -layer with (x, u_q) for some $q \in \{1, 2, \dots, n\}$.

Since $\gamma(G) \geq 3$, $|D_1| = k = \gamma(G) - 1 \geq 2$. So $|W'| \leq |W| - 1$ and by (i) – (iii), W' is a dominating set of $G \boxtimes K_n$.

Now suppose G satisfies Theorem 3.2.3(ii). Since G is connected and $\gamma(G) \geq 3$, it holds that $2\gamma(G) \leq |V(G)|$ and so $\gamma(G) \leq |V(G)| - 3$. Let $4 \leq n < |V(G)| - \gamma(G) + 2$, $X_2 = \{x_2\}$, $X_3 = \{x_3\}$ and $X_1 = \{v_1, \dots, v_k\}$, with $k = \gamma(G) - 1$. Then $W = \{(v, u_1) : v \in X_1\} \cup \{(x_2, u_2)\} \cup \{(x_3, u_i) : i = 3, 4, \dots, n\}$ is a (minimum) dominating set of $G \square K_n$ of cardinality $\gamma(G) + n - 2$. Note that $n < |V(G)|$ and let $\pi = (x_3, x_2, v_1, v_2, \dots, v_{n-2})$, $Y = V(G) - D$ and define the set $W' = (W \cup \{(x_3, u_1), (x_3, u_2)\}) - \{(x_2, u_2), (v_i, u_1) : i = 1, 2, \dots, n - 2\}$.

Then

- (i) $(x_3, u_i) \succ Y_i$ for each $i = 1, 2, \dots, n$ by Theorem 3.2.3;
- (ii) $(v_i, u_1) \succ (v_i, u_j)$ for each $i > n - 2$ and $j = 1, 2, \dots, n$, since $\pi(v_i) = v_i$ if $i > n - 2$, which implies that $\langle \{(v_i, u_j) : j = 1, 2, \dots, n\} \rangle$ is complete;
- (iii) for any $i = 1, 2, \dots, n - 2$, $j = 1, 2, \dots, n$, the vertex (v_i, u_j) is in a K_n -layer with (x_3, u_q) for some $q \in \{1, 2, \dots, n\}$;
- (iv) for any $j = 1, 2, \dots, n$, the vertex (x_2, u_j) is in a K_n -layer with (x_3, u_q) for some $q \in \{1, 2, \dots, n\}$.

Since $\gamma(G) \geq 3$, $|X_1| = k = \gamma(G) - 1 \geq 2$. So $|W'| \leq |W| - 1$ and by (i) – (iv), W' is a dominating set of $G \boxtimes K_n$. ■

Mynhardt and Xu [59] showed that $\gamma(G \boxtimes K_2) > \gamma(G)$ for some π if $\gamma(G) \leq 3$. This result, combined with Proposition 3.6.3, provides the following corollary, which is a weaker result than that of Conjecture 3.6.1, since the case $n = 2$ is just one of the values covered in the statement.

Corollary 3.6.2 *There does not exist a nontrivial connected graph G such that $\gamma(G \boxtimes K_n) = \gamma(G) + n - 2$ for all π and all n with $2 \leq n < |V(G)| - \gamma(G) + 2$. ■*

3.7 Chapter Summary

A graph G is called a consistent fixer if $\gamma(G \square K_n) = \gamma(G) + n - 2$ for each n such that $2 \leq n < |V(G)| - \gamma(G) + 2$. This and other classes of Cartesian fixers were characterized in Section 3.2. A graph attaining equality in the bound $\gamma(G \square K_n) \leq n\gamma(G)$ is called a Cartesian n -multiplier. This class of graphs was characterized in Section 3.3. Concerning the generalized Cartesian product, a graph attaining equality in the upper bound $\gamma(G \boxtimes K_n) \leq n\gamma(G)$ for all π is called a universal multiplier. Such graphs were characterized in Section 3.4 similar to [5] in the case of generalized prisms. A similar problem for the product $G \boxtimes C_n$ was considered in Section 3.5, with conditions on a graph being a so-called cycle multiplier provided. A graph attaining equality in the lower bound $\gamma(G \boxtimes H) \geq \gamma(G)$ for some permutation π is called a π - H -fixer. Section 3.6 conducted a brief investigation into the existence of universal H -fixers, i.e. graphs that are π - H -fixers for some H and all permutations π of $V(G)$.

Chapter 4

Domination Algorithm for Generalized Cartesian Products

4.1 Introduction

In 1994, Livingston and Stout [55] introduced a linear time algorithm to determine $\gamma(G \square P_n)$ for a fixed graph G , using the notion of finite state spaces. They observed that the complexity may be reduced to constant time through an observation of periodicity in the solution. Besides illustrating the applicability to other types of domination, the authors mentioned the algorithm's use to determine $\gamma(G \square P(n))$, where $P(n)$ is a graph from a one-parameter family of graphs, such as a cycle of length n or a complete t -ary tree of height n for fixed t . This chapter explores how the algorithm may be modified to accommodate such graphs and propose a general framework to determine $\gamma(G \square H)$ for any graph H . Furthermore, its use in determining the domination number of the generalized Cartesian product $G \boxtimes H$ is illustrated.

The basic algorithm of Livingston and Stout [55] is explained in Section 4.2 using $K_2 \square P_n$ as an example. A similar example is used in [55], and a more detailed explanation may

be found there. Section 4.3 introduces a general framework for evaluating the domination number of $G \square H$ for a fixed graph G and any H . The problem of determining $\gamma(G \square H)$ is shown to be equivalent to a conditional, weighted homomorphism problem. Section 4.4 provides an algorithm to determine $\gamma(G \square T)$ for any tree T , and observes that it is polynomial for trees of bounded maximum degree. Lastly, Section 4.5 discusses how the general framework for $G \square H$ may be modified to accommodate the generalized Cartesian product $G \boxtimes H$, and provides an example on $G \boxtimes T$, where T is a tree.

4.2 The Cartesian Product $G \square P_n$

In this section, an efficient algorithm, introduced by Livingston and Stout [55], to determine $\gamma(G \square P_n)$ is discussed. Similar to [55], the graph $K_2 \square P_7$ is used as an example to explain the algorithm.

Let D be a dominating set of $G \square P_n$. Label the vertices according to a mapping $l_D : V(G \square P_n) \mapsto \{\leftarrow, \rightarrow, \bullet, \updownarrow\}$, where

$$l_D(v_{i,j}) = \begin{cases} \bullet & \text{if } v_{i,j} \in D \\ \updownarrow & \text{if } v_{i,j} \in N_{G_j}\{D\} \\ \leftarrow & \text{if } v_{i,j-1} \in D \text{ and } v_{i,j} \notin N_{G_j}[D] \\ \rightarrow & \text{if } v_{i,j+1} \in D, v_{i,j-1} \notin D \text{ and } v_{i,j} \notin N_{G_j}[D]. \end{cases}$$

For example, if $D = \{v_{1,1}, v_{2,1}, v_{1,3}, v_{1,5}, v_{2,5}, v_{2,7}\}$ is a dominating set of $K_2 \square P_7$, then its (unique) labelling is illustrated in Figure 4.1.

For any graph G and dominating set D of $G \square P_n$, a labelling l_D of a G -layer G_j satisfies the following two conditions for any $v \in V(G_j)$:

- if $l_D(v) = \bullet$, then $l_D(u) = \updownarrow$ or $l_D(u) = \bullet$ for every $u \in N_{G_j}(v)$;

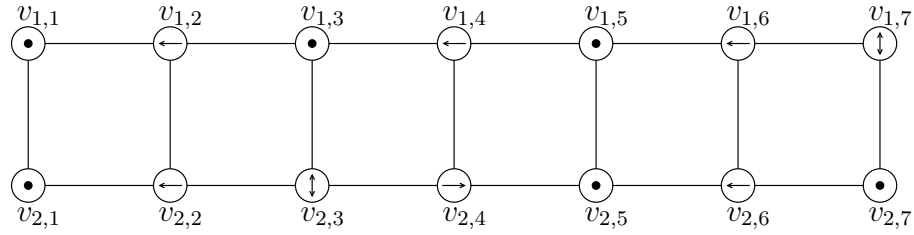


Figure 4.1: The labelling l_D for $K_2 \square P_7$ corresponding to $D = \{v_{1,1}, v_{2,1}, v_{1,3}, v_{1,5}, v_{2,5}, v_{2,7}\}$.

- if $l_D(v) = \uparrow$, then $l_D(u) = \bullet$ for some $u \in N_{G_j}(v)$.

A labelling of $V(G_j)$, written as $l_D(G_j)$, is called a *state* of G . Clearly the number of valid states depends on the structure of G . For the graph $G = K_2$, there are seven valid states, listed in Table 4.1 as column vectors s_0, s_1, \dots, s_6 . Write $[s]_i = l_D(v_{i,j})$ for the i^{th} entry in the state $s = l_D(G_j)$.

s_0	s_1	s_2	s_3	s_4	s_5	s_6
→	→	←	←	•	•	↕
→	←	→	←	•	↕	•

Table 4.1: All possible states of K_2 .

For a canonical labelling of $V(P_n)$ and the resulting grid representation of $G \square P_n$, *state transitions* are defined according to which states are allowed to “follow” each other in the grid representation of the Cartesian product $G \square P_n$. More precisely, a state s in a G -layer G_j may be “followed” by a state t in G_{j+1} if and only if the following conditions hold for all i :

- if $[s]_i = \rightarrow$, then $[t]_i = \bullet$;
- if $[s]_i = \bullet$, then $[t]_i \neq \rightarrow$;
- if $[t]_i = \leftarrow$, then $[s]_i = \bullet$.

From these state transitions a digraph \mathcal{G} , called the *state-transition graph*, is obtained with vertex set the set of all possible states of G , and $st \in E(\mathcal{G})$ if and only if state s may be followed by t for some dominating set D of $G \square P_n$. For the graph $G = K_2$, the state-transition graph $\mathcal{G}(K_2)$ is illustrated in Figure 4.2, with states labelled s_0, s_1, \dots, s_6 according to Table 4.1.

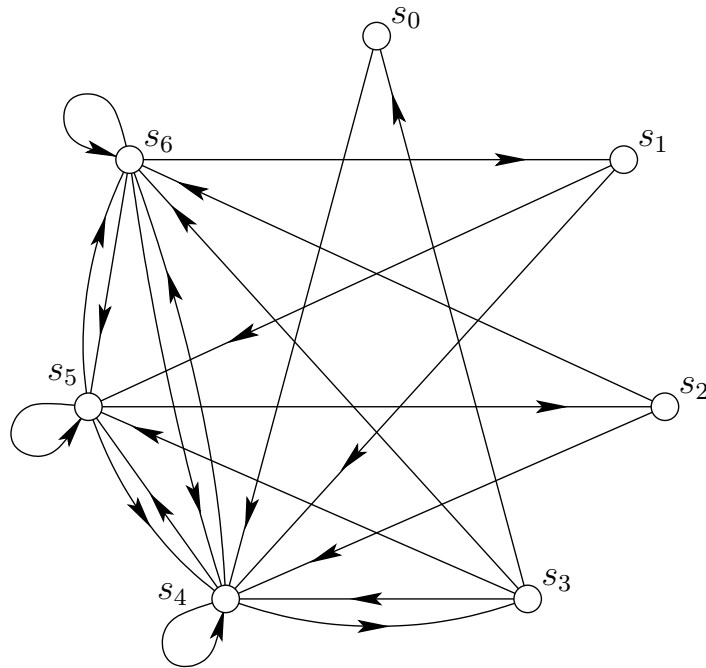


Figure 4.2: The state-transition graph of K_2 .

Special consideration is needed for the first and last G -layers, i.e. G_1 and G_n corresponding to the end-vertices of the path P_n . Let I denote the set of states (vertices of \mathcal{G}) that may be assigned to G_1 , and F be the set of possible states for G_n . For example, if $G = K_2$, then $I = \{s_1, s_4, s_5, s_6\}$ and $F = \{s_3, s_4, s_5, s_6\}$.

Consider a dominating set D of $G \square P_n$. The unique labelling l_D associated with the dominating set D induces a sequence of states $\underline{\alpha} = (\alpha_1, \alpha_2, \dots, \alpha_n)$, where α_i is the state associated with $l_D(G_i)$, $i = 1, 2, \dots, n$. Since $\alpha_i \in V(\mathcal{G})$ for any i , and α_i is followed by α_{i+1} , the state sequence $\underline{\alpha}$ corresponds to a directed walk of length $n - 1$ in \mathcal{G} , starting

with a state in I and ending with a state in F . For example, the dominating set $D = \{v_{1,1}, v_{2,1}, v_{1,3}, v_{1,5}, v_{2,5}, v_{2,7}\}$ of $K_2 \square P_7$ yields the walk $L : s_4, s_3, s_5, s_2, s_4, s_3, s_6$.

Conversely, a directed walk in \mathcal{G} that starts in I and ends in F corresponds to a state sequence that yields a unique dominating set of $G \square P_n$. So there is a one-to-one correspondence between dominating sets of $G \square P_n$ and directed walks of length $n - 1$ in \mathcal{G} starting in I and ending in F .

The vertices of \mathcal{G} can be weighted according to the number of \bullet -labels in the state. If the weight $w(L)$ of a walk L in \mathcal{G} is defined as the sum of the weights of the states in the walk, then the domination number of $G \square P_n$ is given by

$$\gamma(G \square P_n) = \min\{w(L) : L \text{ is a directed walk of length } n - 1 \text{ in } \mathcal{G}(G) \text{ starting in } I \text{ and ending in } F\}.$$

Livingston and Stout [55] discussed an efficient algorithm to find a minimum weight walk in a fixed state-transition graph, thereby determining the domination number of the Cartesian product $G \square P_n$ for fixed G . Considering the graph $K_2 \square P_7$, the walk $s_6, s_1, s_5, s_2, s_6, s_1, s_5$ has minimum weight 4, and the corresponding labelling of $V(K_2 \square P_7)$, from which the minimum dominating set $D = \{v_{2,1}, v_{1,3}, v_{2,5}, v_{1,7}\}$ follows, is shown in Figure 4.3.

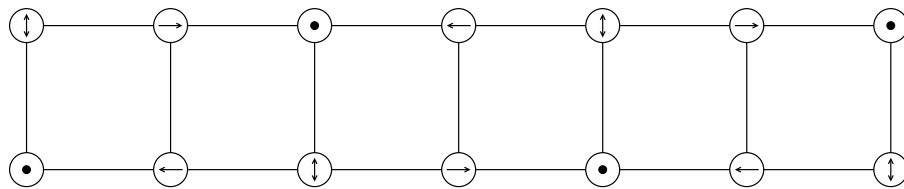


Figure 4.3: The labelling for $K_2 \square P_7$ corresponding to a γ -set $D = \{v_{2,1}, v_{1,3}, v_{2,5}, v_{1,7}\}$.

To determine the state sequence corresponding to a minimum weight directed walk in \mathcal{G} (starting in I and ending in F), a $|V(\mathcal{G})| \times n$ matrix is constructed. Livingston and Stout [55] called this the *cost matrix*, which will be denoted here by M . Each entry in

M consists of a pair of (g, f) , i.e. $[M]_{i,j} = (g(i, j), f(i, j))$. The entry $g(i, j)$ denotes the minimum weight of a directed walk of length $j - 1$ starting in I and ending in state s_{i-1} , $i = 1, 2, \dots, |V(\mathcal{G})|$. If no such walk exists, then $g(i, j)$ is set to some arbitrary large value, which will be denoted by ∞ . The purpose of $f(i, j)$ is to point to the second to last state in a minimum weight directed walk of weight $g(i, j)$. If the walk with weight $g(i, j)$ ending in s_{i-1} , corresponds to the state sequence $(\alpha_1, \alpha_2, \dots, \alpha_j)$ and $\alpha_{j-1} = s_k$, then $f(i, j) = k$. Note that $f(i, 1)$ is meaningless and will be represented by a “–” for every i . If there is more than one possible value for $f(i, j)$, then the smallest one is chosen by convention.

There is a simple recurrence relation defining the values of $g(i, j)$. If $w(s)$ denotes the weight of the state $s \in V(\mathcal{G})$, then for all $i \in \{1, 2, \dots, |V(\mathcal{G})|\}$,

$$g(i, 1) = \begin{cases} w(s_{i-1}) & \text{if } s_{i-1} \in I \\ \infty & \text{otherwise} \end{cases}$$

$$g(i, j + 1) = w(s_{i-1}) + \min_{s_{k-1} \in N_{\text{in}}(s_{i-1})} g(k, j), \quad j \geq 1.$$

It follows that $\gamma(G \square P_n) = \min_{s_{i-1} \in F} g(i, n)$. The state sequence corresponding to a minimum dominating set of $G \square P_n$ may then be reconstructed from the $f(i, j)$ -entries.

The cost matrix used to determine $\gamma(K_2 \square P_7)$ is shown in Table 4.2. Since only $s_3, s_4, s_5, s_6 \in F$, the entries $g(6, 7)$ and $g(7, 7)$ (corresponding to final states s_5 and s_6 respectively) both give the minimum weight of a valid state sequence and therefore the required domination number. For example, the state sequence $(s_6, s_1, s_5, s_2, s_6, s_1, s_5)$ is one of minimum weight 4, and the corresponding labelling of $V(K_2 \square P_7)$ is shown in Figure 4.3, from which the minimum dominating set is clear.

Since determining a $g(i, j)$ -value, $j \geq 2$, in the cost matrix only requires a search through the $(j-1)^{\text{th}}$ column (and selecting a minimum $g(i, j-1)$ -value), it is clear that the algorithm has a linear time complexity in the order n of the path. Livingston and Stout [55] observed

	1	2	3	4	5	6	7
s_0	(0,-)	(∞ ,3)	(2,3)	(2,3)	(3,3)	(4,3)	(4,3)
s_1	(∞ ,-)	(1,6)	(2,6)	(2,6)	(3,6)	(3,6)	(4,6)
s_2	(∞ ,-)	(1,5)	(2,5)	(2,5)	(3,5)	(3,5)	(4,5)
s_3	(∞ ,-)	(2,4)	(2,4)	(3,4)	(4,4)	(4,4)	(5,4)
s_4	(2,-)	(2,0)	(3,1)	(4,0)	(4,0)	(5,0)	(5,1)
s_5	(1,-)	(2,5)	(2,1)	(3,1)	(3,1)	(4,1)	(4,1)
s_6	(1,-)	(2,5)	(2,2)	(3,2)	(3,2)	(4,2)	(4,2)

Table 4.2: *The cost matrix used to determine $\gamma(G \square P_7)$.*

a periodicity in the columns of the cost matrix. Once this periodic behaviour occurs, the domination number is determined without further computation. From this observation they deduced a constant time complexity for the problem of determining $\gamma(G \square P_n)$ for fixed G .

When considering the product $G \square C_n$, the algorithm can be modified easily without changing the complexity. Since the state-transition graph \mathcal{G} simply depends on G and the type of graph product, it is obtained in exactly the same manner. However, in this case there is a one-to-one correspondence between dominating sets of $G \square C_n$ and directed circuits of length n in \mathcal{G} . Repeated application of the algorithm can be used to determine minimum weight directed walks of length $n - 1$, thereby determining a minimum weight circuit in \mathcal{G} .

It is unclear whether the algorithm can be modified easily to accommodate graphs $G \square H$ if H has many vertices of degree greater than 2. A more general framework is required for determining $\gamma(G \square H)$.

4.3 A General Framework for $\gamma(G \square H)$

In this section the algorithm by Livingston and Stout [55] is generalized in order to determine $\gamma(G \square H)$ for any graph H .

Let D be a dominating set of $G \square H$ and \vec{H} an orientation of H . As in Section 4.2, a state-transition graph \mathcal{G} is constructed with vertex set the set of all possible states of G . Once again, write $[s]_i = l_D(v_{i,j})$ for the i^{th} entry in the state $s = l_D(G_j)$.

The arc set of the digraph \mathcal{G} is now given by the following condition:

- $st \in E(\mathcal{G})$ if and only if for every i : if $[s]_i = \bullet$, then $[t]_i \neq \rightarrow$.

Next, assign a *binary colour vector* $\underline{c} = (c_0, c_1, \dots, c_m)$ to each arc st in \mathcal{G} . This assignment satisfies the following conditions, which hold for all i . Let $[\underline{c}]_k$ denote the $(k+1)^{\text{st}}$ entry in the vector.

- $[\underline{c}(st)]_0 = 1$ if and only if $st \in E(\mathcal{G})$;
- for any $t \in N_{\text{out}}(s)$ with $[t]_i = \bullet$, $[\underline{c}(st)]_i = 1$ if and only if $[s]_i = \rightarrow$;
- for any $t \in N_{\text{out}}(s)$ with $[s]_i = \bullet$, $[\underline{c}(st)]_i = 1$ if and only if $[t]_i = \leftarrow$.

For the example $G = K_2$, with corresponding vertex set $\{s_0, s_1, \dots, s_6\}$ of \mathcal{G} listed in Table 4.1, there are only seven arcs not in \mathcal{G} , namely $s_6s_0, s_6s_2, s_5s_0, s_5s_1, s_4s_0, s_4s_1$ and s_4s_2 . If the colours c_0, c_1 and c_2 are viewed as “no colour”, “blue” and “red” respectively, then

- $c_0(e) = 1$ for all $e \in E(\mathcal{G})$ (all arcs have the no-colour attribute);
- $\underline{c}(e) = (1, 1, 0)$ for $e = s_0s_5, s_1s_4, s_1s_5, s_5s_2, s_5s_3$ (the arcs $s_0s_5, s_1s_4, s_1s_5, s_5s_2$ and s_5s_3 have a blue attribute but not red);
- $\underline{c}(e) = (1, 0, 1)$ for $e = s_0s_6, s_2s_4, s_6s_1, s_6s_3$ (the arcs s_0s_6, s_2s_4, s_6s_1 and s_6s_3 have a red attribute but not blue);
- $\underline{c}(e) = (1, 1, 1)$ for $e = s_0s_4, s_4s_3$ (the arcs s_0s_4 and s_4s_3 have both a blue and red attribute).

This state-transition graph \mathcal{G} is illustrated in Figure 4.4. Dashed arcs have colour vector $(1, 1, 0)$ (the blue attribute only), dashed-dotted arcs have colour vector $(1, 0, 1)$ (the red attribute only), solid arcs have colour vector $(1, 1, 1)$ (both the red and blue attribute). The arcs not shown are in \mathcal{G} and have colour vector $(1, 0, 0)$, while the dotted arcs are not present in the graph.

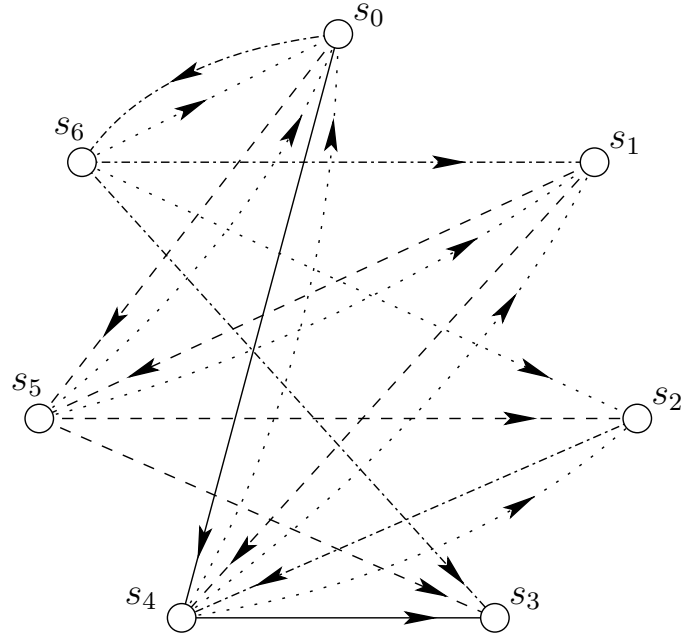


Figure 4.4: The state-transition graph \mathcal{G} of K_2 .

Let $P, Q \subseteq \{1, 2, \dots, m\}$. The unique labelling l_D associated with the dominating set D induces a sequence of states $\alpha_1, \alpha_2, \dots, \alpha_n$, where $\alpha_j = l_D(G_j)$, $j = 1, 2, \dots, n$. This sequence corresponds uniquely to a homomorphism $f : \vec{H} \mapsto \mathcal{G}$, with $f(u_j) = \alpha_j$, satisfying the following condition:

- if $f(u) = s \in V(\mathcal{G})$, $[s]_i = \leftarrow$ for $i \in P$ and $[s]_k = \rightarrow$ for $k \in Q$, then

for any $i \in P$, $[\underline{c}(f(wu))]_i = 1$ for some $w \in N_{\text{in}}(u)$;

for any $k \in Q$, $[\underline{c}(f(uw))]_k = 1$ for some $w \in N_{\text{out}}(u)$.

For example, for the product $K_2 \square H$, the homomorphism $f : \vec{H} \mapsto \mathcal{G}(K_2)$ has the property that if s_0 is an image under f , then over all arcs *from* s_0 in the image of $f(E(\vec{H}))$, there is a blue and a red attribute represented. If s_1 is an image under f , then over all arcs *from* s_1 in the image of $f(E(\vec{H}))$, there is a blue attribute represented, while over all arcs *to* s_1 in the image of $f(E(\vec{H}))$, there is a red attribute represented.

Conversely, a conditional homomorphism $f : \vec{H} \mapsto \mathcal{G}$ satisfying the property above corresponds to a state sequence that yields a unique dominating set of $G \square H$. There is a one-to-one correspondence between dominating sets of $G \square H$ and conditional homomorphisms $f : \vec{H} \mapsto \mathcal{G}$ for some orientation of H . Denote the set of such homomorphisms by $\text{HOM}(\vec{H}, \mathcal{G})$. Note that the orientation of H is used only to establish the one-to-one correspondence between the dominating sets of $G \square H$ and the state sequence.

Similar to Section 4.2, the vertices of \mathcal{G} can be weighted according to the number of \bullet -labels in the state. Let the weight $w(f(\vec{H}))$ of the homomorphic image of \vec{H} under f in \mathcal{G} be defined as the sum of the weights of the images, i.e.

$$w(f(\vec{H})) = \sum_{v \in V(\vec{H})} w(f(v)).$$

Then the domination number of $G \square H$ is given by

$$\gamma(G \square H) = \min\{w(f(\vec{H})) : f \in \text{HOM}(\vec{H}, \mathcal{G})\}.$$

For $H = P_n$ a canonical labelling of H yields a directed path \vec{H} in which every vertex has in-degree and out-degree at most 1. This simplifies the state-transition graph \mathcal{G} , since homomorphisms satisfying the required property only include arcs with colour vectors $(1, 0, \dots, 0)$ and/or $(1, 0, \dots, 0, 1)$ (only “no-colour” or both “blue” and “red” arcs in the case of $G = K_2$). In this case the colour vectors play no role in the correspondence, and the

state-transition graph reduces to the graph defined in Section 4.2. The method introduced by Livingston and Stout [55] is a special case of the general method discussed in this section.

4.4 An Algorithm for $\gamma(G \square T)$

An implementation of the general framework described in the previous section is illustrated by providing an algorithm to find the domination number of $G \square T$ for any tree T . The algorithm format used in [49] is followed. Throughout the following algorithms, external functions are used in an intuitive manner. These functions are named so that their use is clear.

Let $V(T) = \{v_0, v_1, \dots, v_{n-1}\}$ and denote the tree rooted at a vertex v by T_v . The main algorithm `GAMMA()`, shown as Algorithm 4.4.1, starts by constructing the state-transition graph \mathcal{G} of G by way of the function `STATEGRAPH()`. In addition to the state-transition graph, this function also returns information about the colour vectors of the arcs that can be used by all subalgorithms. Let the states (vertices in \mathcal{G}) be denoted s_0, s_1, \dots, s_{N-1} . The colour vector of an arc in \mathcal{G} is returned by the function `CVECT()`. For each state in \mathcal{G} , there is an associated incoming colour requirement vector (a binary vector with entry 1 corresponding to rows with label “ \leftarrow ”). Similarly, an outgoing colour requirement vector is associated with each state in \mathcal{G} , according to the “ \rightarrow ” labels in the state. The incoming colour requirement vector of a vertex in \mathcal{G} is returned by the function `INC()`, while `OUTC()` returns the outgoing colour requirement vector. For a vertex $u \in V(T_v)$, let T_u denote the subtree of T_v induced by u and its descendants.

The algorithm `GAMMA()` visits the vertices of T_v in a reversed breadth-first-search (BFS) order to construct two $N \times n$ matrices, denoted W and P , one column at a time. The $(i+1, j+1)$ -entry of W is the minimum weight of a conditional homomorphism $\phi_u : T_u \mapsto \mathcal{G}$ such that $\phi_u(u) = s_i$, where $u = v_j$. The corresponding entry in P contains such a minimum

homomorphism ϕ_u , restricted to $N_{\text{out}}(u)$, the children of $u = v_j$ (for efficiency). Denote this restricted homomorphism by $\phi_u^{(c)}$. For each $v_j \in V(T_v)$ and each $s_i \in V(\mathcal{G})$, the subalgorithm $\text{MINHOM}()$ is called to determine the $(i + 1, j + 1)$ -entry in both W and P . This algorithm is shown as Algorithm 4.4.3.

Algorithm 4.4.1: $\text{GAMMA}(G, T_v, v)$

comment: $\left\{ \begin{array}{l} \text{Returns } \gamma(G \square T) \text{ and a minimum dominating set } D. \\ T_v \text{ is the tree } T \text{ rooted at vertex } v. \end{array} \right.$

external $\left\{ \begin{array}{l} \text{STATEGRAPH}(), \text{MINHOM}(), \text{ROOTIMAGELIST}() \\ \text{BFS}(), \text{REVERSE}(), \text{MIN}(), \text{DOMSET}(), \text{MAKEHOM}() \end{array} \right.$

$\mathcal{G} \leftarrow \text{STATEGRAPH}(G)$
 $\text{treelist} \leftarrow \text{BFS}(T_v)$
 $\text{revtreelist} \leftarrow \text{REVERSE}(\text{treelist})$

for each u **in** treelist

do $\left\{ \begin{array}{l} \text{for each } s \text{ in } V(\mathcal{G}) \\ \text{do } \left\{ \begin{array}{l} g_u, \phi_u^{(c)} \leftarrow \text{MINHOM}(T_v, \mathcal{G}, u, s, W) \\ W(s, u) \leftarrow g_u \\ P(s, u) \leftarrow \phi_u^{(c)} \end{array} \right. \end{array} \right.$

$F \leftarrow \text{ROOTIMAGELIST}(\mathcal{G})$
 $\gamma, \text{vimg} \leftarrow \text{MIN}(W(F, v))$
 $\phi_v \leftarrow \text{MAKEHOM}(v, \text{vimg}, P)$
 $D \leftarrow \text{DOMSET}(\phi)$

return (γ, D)

Since $\text{deg}_{\text{in}}(v) = 0$ for the root v of T_v , only a subset of the states in \mathcal{G} are valid images for v . The subalgorithm $\text{ROOTIMAGELIST}()$, shown as Algorithm 4.4.2, determines this subset $F \subseteq V(\mathcal{G})$. If $v = v_j$ is the root of T_v , then $\gamma(G \square T) = \min_{s_i \in F} W(i + 1, j + 1)$. The function $\text{MIN}()$ returns the minimum weight and an image of v that yields such a weight. The minimum conditional homomorphism $\phi_v : T_v \mapsto \mathcal{G}$ can be obtained easily from the

Algorithm 4.4.2: ROOTIMAGELIST(\mathcal{G})

comment: $\left\{ \begin{array}{l} \text{Returns the set of valid states for the root of a tree.} \\ \mathcal{G} \text{ is the state-transition graph.} \end{array} \right.$

external INC(), EMPTYLIST(), APPEND()

$list \leftarrow \text{EMPTYLIST}()$

for each s **in** $V(\mathcal{G})$

do $\left\{ \begin{array}{l} \text{if } \text{INC}(\mathcal{G}, s) = \underline{0} \\ \text{then } list \leftarrow \text{APPEND}(list, s) \end{array} \right.$

return ($list$)

appropriate entries in P , and the minimum dominating set corresponding to ϕ_v follows directly.

When considering $T \cong P_n$, this algorithm is the same as the one used by Livingston and Stout [55] and described in Section 4.2. Selecting a leaf as the root v of the tree, the reversed BFS ordering simply corresponds to a canonical labelling of the path ending in v . The set F contains the valid images (or final states) of the right-most vertex v in the path.

It remains to briefly explain the subalgorithm MINHOM() that is used to determine a single entry in each of the matrices W and P . As input it takes the rooted tree T_v , the state-transition graph \mathcal{G} , a vertex $u \in V(T_v)$, a state $s \in V(\mathcal{G})$ and the weight-matrix W . As mentioned previously, it determines the minimum weight g_u of a conditional homomorphism $\phi_u : T_u \mapsto \mathcal{G}$ such that $\phi_u(u) = s$, and returns this weight and $\phi_u^{(c)} = \phi_u|N_{\text{out}}(u)$, the homomorphism ϕ_u restricted to the set of children of u (if it exists).

If u is a leaf in T_v , then the algorithm verifies whether s is a valid image for u , since only states with no outgoing colour requirements are allowed to be images of leaves. If s is a valid image, g_u is set to the weight of s . Otherwise it is set to some large value, which we

denote here by ∞ . If u is a leaf in T_v , no homomorphism $\phi_u^{(c)}$ is returned.

Algorithm 4.4.3: MINHOM($T_v, \mathcal{G}, u, s, W$)

comment: $\left\{ \begin{array}{l} \text{Returns the weight of a minimum homomorphism} \\ \phi_u : T_u \mapsto \mathcal{G} \text{ as well as } \phi_u^{(c)} = \phi_u|C(u), \\ \text{such that } \phi_u(u) = s. \\ T_v \text{ is the tree } T \text{ rooted at vertex } v. \\ \mathcal{G} \text{ is the state-transition graph and } W \text{ the weight matrix.} \end{array} \right.$

external $\left\{ \begin{array}{l} \text{OUTC}(), \text{ISLEAF}(), \text{WEIGHT}(), \text{CHILDREN}(), \\ \text{LENGTH}(), \text{EMPTYHOM}(), \text{TUPLE}(), \\ \text{CHILDIMAGELIST}(), \text{COLOURCHECK}() \end{array} \right.$

$g_u \leftarrow \infty$
 $\phi_u^{(c)} \leftarrow \text{EMPTYHOM}()$

if ISLEAF(T_v, u)

then $\left\{ \begin{array}{l} \text{if } \text{OUTC}(\mathcal{G}, s) = \underline{0} \\ \text{then } g_u \leftarrow \text{WEIGHT}(s) \end{array} \right.$

$\left\{ \begin{array}{l} \text{childlist} \leftarrow \text{CHILDREN}(T_v, u) \\ k \leftarrow \text{LENGTH}(\text{childlist}) \\ \text{slist} \leftarrow \text{CHILDIMAGELIST}(\mathcal{G}, s) \\ \text{for each } X \text{ in } \text{TUPLE}(\text{slist}, k) \end{array} \right.$

else $\left\{ \begin{array}{l} \text{if } \text{COLOURCHECK}(T_v, \mathcal{G}, u, s, \text{childlist}, X) \\ \text{do } \left\{ \begin{array}{l} \text{if } \text{COLOURCHECK}(T_v, \mathcal{G}, u, s, \text{childlist}, X) \\ \text{then } \left\{ \begin{array}{l} \text{gtmp} \leftarrow \text{WEIGHT}(s) \\ \text{for } i \leftarrow 1 \text{ to } \text{LENGTH}(\text{childlist}) \\ \text{do } \text{gtmp} \leftarrow \text{gtmp} + W(\text{childlist}(i), X(i)) \\ \text{if } \text{gtmp} < g_u \\ \text{then } \left\{ \begin{array}{l} g_u \leftarrow \text{gtmp} \\ \phi_u^{(c)}(\text{childlist}) \leftarrow X \end{array} \right. \end{array} \right. \end{array} \right. \end{array} \right.$

return ($g_u, \phi_u^{(c)}$)

Algorithm 4.4.4: CHILDIMAGELIST(\mathcal{G}, s)

comment: $\left\{ \begin{array}{l} \text{Returns the set of valid images} \\ \text{for the children of a vertex mapping to } s. \\ \mathcal{G} \text{ is the state-transition graph.} \end{array} \right.$

external INC(), CVECT(), EMPTYLIST(), APPEND()

$list \leftarrow \text{EMPTYLIST}()$

for each t **in** $V(\mathcal{G})$

do $\left\{ \begin{array}{l} \text{if } (s, t) \in E(\mathcal{G}) \text{ and } \text{CVECT}(\mathcal{G}, s, t) \geq \text{INC}(\mathcal{G}, t) \\ \text{then } list \leftarrow \text{APPEND}(list, t) \end{array} \right.$

return ($list$)

Algorithm 4.4.5: COLOURCHECK($T_v, \mathcal{G}, u, s, childlist, X$)

comment: $\left\{ \begin{array}{l} \text{Returns } \text{true} \text{ if the mapping given by } u \mapsto s \text{ and} \\ childlist \mapsto X \text{ is valid for some homomorphism } T_v \mapsto \mathcal{G}. \\ T_v \text{ is a rooted tree and } \mathcal{G} \text{ is the state-transition graph.} \end{array} \right.$

external CVECT(), OUTC(), ORSUM(), ISLEAF(), LENGTH()

$vect \leftarrow \underline{0}$

for each t **in** X

do $vect \leftarrow \text{ORSUM}(vect, \text{CVECT}(\mathcal{G}, s, t))$

if $\text{OUTC}(\mathcal{G}, s) > vect$

then return (**false**)

for $i \leftarrow 1$ **to** $\text{LENGTH}(childlist)$

do $\left\{ \begin{array}{l} w \leftarrow childlist(i) \\ t \leftarrow X(i) \\ \text{if } \text{ISLEAF}(T_v, w) \text{ and not } \text{OUTC}(\mathcal{G}, t) = \underline{0} \\ \text{then return (false)} \end{array} \right.$

return (**true**)

Suppose u is not a leaf in T_v and let $C(u)$ denote the set of k children of u , i.e. $C(u) = N_{\text{out}}(u)$ and $k = \text{deg}_{\text{out}}(u)$. The subalgorithm CHILDIMAGELIST() reduces the set of valid images for $C(u)$, and is shown as Algorithm 4.4.4. It checks that a state $t \in V(\mathcal{G})$ is adjacent

s_0	s_1	s_2	s_3	s_4	s_5	s_6	s_7	s_8	s_9	s_{10}	s_{11}	s_{12}	s_{13}	s_{14}	s_{15}	s_{16}
→	→	→	→	→	←	←	←	←	←	•	•	•	•	•	↕	↕
→	→	←	←	↕	→	→	←	←	↕	•	•	↕	↕	↕	•	•
→	←	→	←	•	→	←	→	←	•	•	↕	→	←	•	•	↕

Table 4.3: All possible states of P_3 , i.e. the vertices of $\mathcal{G}(P_3)$.

from $s = \phi_u(u)$ and that the colour vector of the arc $st \in E(\mathcal{G})$ satisfies the incoming colour requirement of t . The algorithm `MINHOM()` calls this subset of valid images *slit*. For every k -tuple X of *slit*, it is verified by way of `COLOURCHECK()` that the corresponding homomorphism $C(u) \mapsto X$ is valid, in terms of the outgoing colour requirement on $s = \phi_u(u)$ and the additional requirement on the images of leaves. This subalgorithm is shown as Algorithm 4.4.5. Lastly, the minimum weight over all valid k -tuples is determined and returned as the value of g_u , with $\phi_u^{(c)}$ the corresponding homomorphism $T_u \mapsto \mathcal{G}$ restricted to $C(u)$.

As an example, consider the tree T with vertex set $V(T) = \{v_0, v_1, \dots, v_5\}$, rooted at v_0 , as shown in Figure 4.5. The states in the state-transition graph \mathcal{G} of P_3 are listed in Table 4.3 as column vectors. Calling the algorithm `GAMMA(P_3, T_v, v_0)` to determine $\gamma(P_3 \square T)$ yields the information shown in Table 4.4. This table shows corresponding entries of the matrices W and P . The set of valid states for the root v_0 is $F = \{s_0, s_4, s_{10}, s_{11}, s_{12}, s_{14}, s_{15}, s_{16}\}$. The images s_4, s_{12} and s_{16} of v_0 all yield a minimum weight of 5 for a conditional homomorphism $\phi : T_v \mapsto \mathcal{G}$, so that $\gamma(P_3 \square T) = 5$. For example, the image s_4 of v_0 yields $\phi = \{v_0 \mapsto s_4, v_1 \mapsto s_{13}, v_2 \mapsto s_5, v_3 \mapsto s_4, v_4 \mapsto s_{13}, v_5 \mapsto s_{16}\}$, shown in Figure 4.6. The corresponding minimum dominating set of $P_3 \square T$ is shown in Figure 4.7.

The complexity of the algorithm `GAMMA()` is noted briefly. For a fixed graph G , the state-transition graph is constructed in constant time complexity. A breadth-first search through the tree T_v of order n has complexity $\mathcal{O}(n)$. For each of the n vertices in the tree, each of the N states is considered, and the subalgorithm `MINHOM()` is called. If the out-degree

	v_4	v_5	v_3	v_2	v_1	v_0
s_0	$\infty \mid -$	$\infty \mid -$	$3 \mid \{v_4 \mapsto s_{10}\}$	$4 \mid \{v_3 \mapsto s_4, v_5 \mapsto s_{11}\}$	$4 \mid \{v_2 \mapsto s_{10}\}$	$6 \mid \{v_1 \mapsto s_{10}\}$
s_1	$\infty \mid -$	$\infty \mid -$	$2 \mid \{v_4 \mapsto s_{11}\}$	$3 \mid \{v_3 \mapsto s_{12}, v_5 \mapsto s_{16}\}$	$4 \mid \{v_2 \mapsto s_{10}\}$	$5 \mid \{v_1 \mapsto s_{11}\}$
s_2	$\infty \mid -$	$\infty \mid -$	$2 \mid \{v_4 \mapsto s_{14}\}$	$4 \mid \{v_3 \mapsto s_4, v_5 \mapsto s_{11}\}$	$4 \mid \{v_2 \mapsto s_{10}\}$	$5 \mid \{v_1 \mapsto s_{14}\}$
s_3	$\infty \mid -$	$\infty \mid -$	$2 \mid \{v_4 \mapsto s_{11}\}$	$3 \mid \{v_3 \mapsto s_{12}, v_5 \mapsto s_{16}\}$	$4 \mid \{v_2 \mapsto s_{10}\}$	$5 \mid \{v_1 \mapsto s_{11}\}$
s_4	$\infty \mid -$	$\infty \mid -$	$2 \mid \{v_4 \mapsto s_{13}\}$	$4 \mid \{v_3 \mapsto s_1, v_5 \mapsto s_{13}\}$	$5 \mid \{v_2 \mapsto s_{10}\}$	$5 \mid \{v_1 \mapsto s_{13}\}$
s_5	$\infty \mid -$	$\infty \mid -$	$2 \mid \{v_4 \mapsto s_{15}\}$	$3 \mid \{v_3 \mapsto s_4, v_5 \mapsto s_{16}\}$	$4 \mid \{v_2 \mapsto s_{10}\}$	$5 \mid \{v_1 \mapsto s_{15}\}$
s_6	$\infty \mid -$	$\infty \mid -$	$1 \mid \{v_4 \mapsto s_{16}\}$	$3 \mid \{v_3 \mapsto s_4, v_5 \mapsto s_{16}\}$	$4 \mid \{v_2 \mapsto s_{10}\}$	$5 \mid \{v_1 \mapsto s_{11}\}$
s_7	$\infty \mid -$	$\infty \mid -$	$2 \mid \{v_4 \mapsto s_{14}\}$	$3 \mid \{v_3 \mapsto s_4, v_5 \mapsto s_{16}\}$	$4 \mid \{v_2 \mapsto s_4\}$	$5 \mid \{v_1 \mapsto s_4\}$
s_8	$0 \mid -$	$0 \mid -$	$1 \mid \{v_4 \mapsto s_{16}\}$	$3 \mid \{v_3 \mapsto s_4, v_5 \mapsto s_{16}\}$	$4 \mid \{v_2 \mapsto s_0\}$	$4 \mid \{v_1 \mapsto s_0\}$
s_9	$1 \mid -$	$1 \mid -$	$2 \mid \{v_4 \mapsto s_{13}\}$	$4 \mid \{v_3 \mapsto s_1, v_5 \mapsto s_{13}\}$	$4 \mid \{v_2 \mapsto s_1\}$	$5 \mid \{v_1 \mapsto s_1\}$
s_{10}	$3 \mid -$	$3 \mid -$	$3 \mid \{v_4 \mapsto s_8\}$	$4 \mid \{v_3 \mapsto s_8, v_5 \mapsto s_8\}$	$6 \mid \{v_2 \mapsto s_8\}$	$7 \mid \{v_1 \mapsto s_8\}$
s_{11}	$2 \mid -$	$2 \mid -$	$3 \mid \{v_4 \mapsto s_9\}$	$5 \mid \{v_3 \mapsto s_7, v_5 \mapsto s_9\}$	$5 \mid \{v_2 \mapsto s_7\}$	$6 \mid \{v_1 \mapsto s_7\}$
s_{12}	$\infty \mid -$	$\infty \mid -$	$2 \mid \{v_4 \mapsto s_9\}$	$4 \mid \{v_3 \mapsto s_5, v_5 \mapsto s_9\}$	$5 \mid \{v_2 \mapsto s_9\}$	$5 \mid \{v_1 \mapsto s_9\}$
s_{13}	$1 \mid -$	$1 \mid -$	$2 \mid \{v_4 \mapsto s_9\}$	$4 \mid \{v_3 \mapsto s_5, v_5 \mapsto s_9\}$	$4 \mid \{v_2 \mapsto s_5\}$	$5 \mid \{v_1 \mapsto s_5\}$
s_{14}	$2 \mid -$	$2 \mid -$	$3 \mid \{v_4 \mapsto s_9\}$	$4 \mid \{v_3 \mapsto s_6, v_5 \mapsto s_9\}$	$5 \mid \{v_2 \mapsto s_6\}$	$6 \mid \{v_1 \mapsto s_6\}$
s_{15}	$2 \mid -$	$2 \mid -$	$3 \mid \{v_4 \mapsto s_{13}\}$	$5 \mid \{v_3 \mapsto s_3, v_5 \mapsto s_{13}\}$	$5 \mid \{v_2 \mapsto s_3\}$	$6 \mid \{v_1 \mapsto s_3\}$
s_{16}	$1 \mid -$	$1 \mid -$	$2 \mid \{v_4 \mapsto s_{16}\}$	$4 \mid \{v_3 \mapsto s_2, v_5 \mapsto s_{16}\}$	$5 \mid \{v_2 \mapsto s_2\}$	$5 \mid \{v_1 \mapsto s_2\}$

Table 4.4: The corresponding entries of the matrices W and P used to determine $\gamma(P_3 \square T)$.

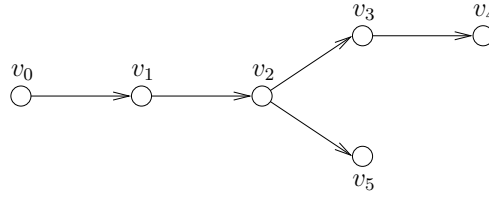


Figure 4.5: The tree T rooted at vertex v_0 .

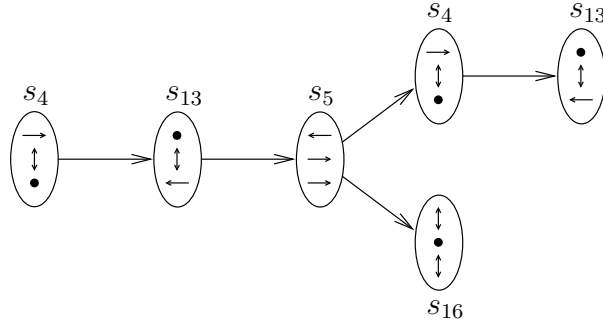


Figure 4.6: A minimum weight conditional homomorphism $\phi : T_v \mapsto \mathcal{G}$.

of a vertex u in T_v is k , then this subalgorithm considers every k -tuple of a set of at most N states, possibly looking through all the k weight-matrix entries corresponding to the children of u . Thus the complexity is $\mathcal{O}(n\Delta N^{\Delta+1} + n)$. For a family of trees of bounded maximum degree, this yields a polynomial time algorithm.

4.5 The Generalized Cartesian Product $G \boxtimes H$

The general framework presented in Section 4.3 to determine the domination number of $G \square H$ need only be modified slightly to accommodate the generalized Cartesian product $G \boxtimes H$. Let $V(H) = \{u_1, u_2, \dots, u_n\}$ and π be a permutation of $V(G)$. Also, let D be a dominating set of $G \boxtimes H$ and the mapping $l_D : V(G \boxtimes H) \mapsto \{\leftarrow, \rightarrow, \bullet, \updownarrow\}$ be defined as in Section 4.3. Write $[s]_i = l_D(v_{i,j})$ for the i^{th} entry in the state $s = l_D(G_j)$ as before. For $a = 1, 2, \dots, n - 1$, let \mathcal{G}_a denote a state-transition graph of G with vertex set the set of

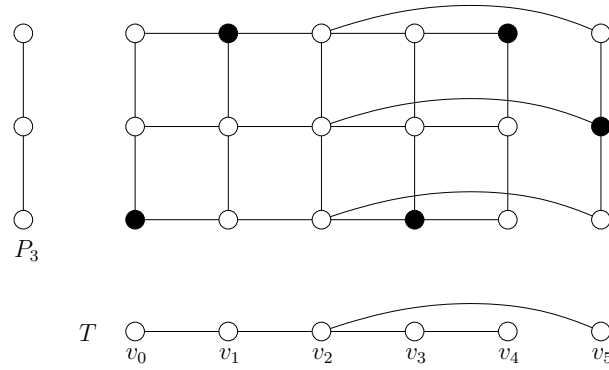


Figure 4.7: A minimum dominating set of $P_3 \boxtimes T$.

valid states of G , and $st \in E(\mathcal{G}_a)$ if and only if for any i :

- if $[s]_i = \bullet$, then $[t]_{\pi^a(i)} \neq \rightarrow$.

Depending on the permutation π , many of these digraphs \mathcal{G}_a may be the same, but for the sake of simplicity they will be considered to be distinct here. Let $N^{(a)}(s)$ denote the neighbourhood of s in \mathcal{G}_a . Colour vectors \underline{c}_a for the arcs of \mathcal{G}_a are defined similar to those in Section 4.3 according to the following conditions, which hold for all i :

- $[\underline{c}_a(st)]_0 = 1$ if and only if $st \in E(\mathcal{G}_a)$;
- for any $t \in N_{\text{out}}^{(a)}(s)$ with $[t]_{\pi^a(i)} = \bullet$, $[\underline{c}_a(st)]_i = 1$ if and only if $[s]_i = \rightarrow$;
- for any $t \in N_{\text{out}}^{(a)}(s)$ with $[s]_i = \bullet$, $[\underline{c}_a(st)]_i = 1$ if and only if $[t]_{\pi^a(i)} = \leftarrow$.

Let \vec{H} be an acyclic orientation of H such that $j > i$ if $v_i v_j \in E(\vec{H})$ (i.e. all the arcs are forward arcs). The labelling associated with a dominating set D of $G \boxtimes H$ induces a sequence of states $\alpha_1, \alpha_2, \dots, \alpha_n$ that corresponds uniquely to a mapping $f : V(\vec{H}) \mapsto V(\mathcal{G})$, with $f(v_i) = \alpha_i$, satisfying the following conditions:

- if $v_i v_j \in E(\vec{H})$, then $f(v_i) f(v_j) \in E(\mathcal{G}_{j-i})$;

- if $f(v_i) = s \in V(\mathcal{G})$, $[s]_p = \leftarrow$ for $p \in P$ and $[s]_q = \rightarrow$ for $q \in Q$, $P, Q \subseteq \{1, 2, \dots, m\}$, then

for any $p \in P$, $[\underline{c}_{i-j}(f(v_j)f(v_i))]_p = 1$ for some $v_j \in N_{\text{in}}(v_i)$;

for any $q \in Q$, $[\underline{c}_{j-i}(f(v_i)f(v_j))]_q = 1$ for some $v_j \in N_{\text{out}}(v_i)$.

Conversely, a mapping $f : V(\vec{H}) \mapsto V(\mathcal{G})$ satisfying the properties above corresponds to a state sequence and therefore a unique dominating set of $G \boxtimes H$. The minimum weight of such a mapping yields the domination number of the generalized Cartesian product $G \boxtimes H$.

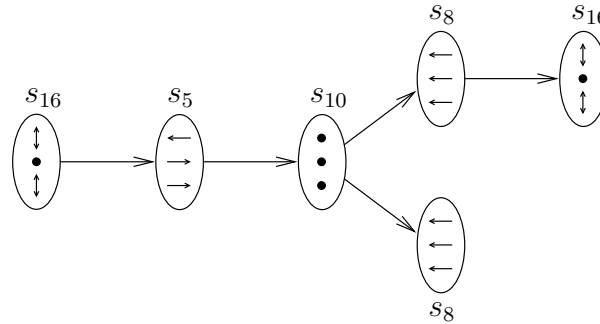


Figure 4.8: A minimum weight mapping $\phi : V(T_v) \mapsto V(\mathcal{G})$.

As an example, consider $P_3 \boxtimes T$, where $\pi = (w_1, w_2)$ is a permutation of $V(P_3) = \{w_1, w_2, w_3\}$ and T is the tree with vertex set $V(T) = \{v_0, v_1, \dots, v_5\}$, rooted at v_0 , as shown in Figure 4.5. A slight modification of the algorithm used in Section 4.4, in accordance with the above discussion, may be used to determine the domination number of this generalized Cartesian product (and in fact any product $G \boxtimes T$ for any tree T). The mapping $\phi = \{v_0 \mapsto s_{16}, v_1 \mapsto s_5, v_2 \mapsto s_{10}, v_3 \mapsto s_8, v_4 \mapsto s_{16}, v_5 \mapsto s_8\}$ yields a minimum weight of 5, showing that $\gamma(P_3 \boxtimes T) = 5$. This mapping and the corresponding minimum dominating set of $P_3 \boxtimes T$ are shown in Figures 4.8 and 4.9 respectively.

As additional examples, the domination number of the product $C_m \boxtimes C_n$ is determined for various values of m and n . For specific values of m and n , these domination numbers

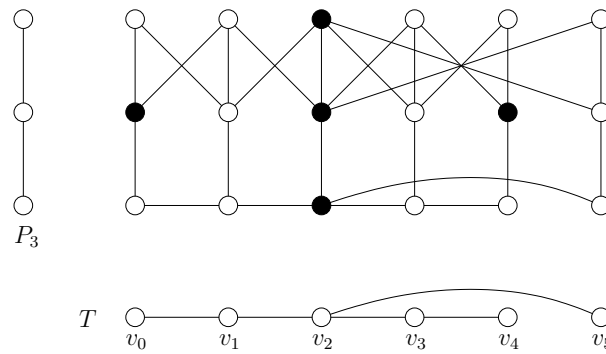


Figure 4.9: A minimum dominating set of $P_3 \boxtimes T$, $\pi = (w_1, w_2)$.

vary over the set of permutations of $V(C_m)$. Table 4.5 shows the minimum and maximum domination numbers $\gamma(C_5 \boxtimes C_n)$ for some sample values of n , denoted γ_{min} and γ_{max} respectively.

n	$\gamma_{min}(C_5 \boxtimes C_n)$	$\gamma(C_5 \square C_n)$	$\gamma_{max}(C_5 \boxtimes C_n)$
5	5	5	7
6	6	7	8
7	8	8	9
8	8	10	10
9	9	10	11
15	15	15	19
16	16	17	20
17	18	18	21
18	18	20	23
19	20	20	24
35	35	35	44
36	36	37	45
37	38	38	46
38	39	40	48
39	39	40	49

Table 4.5: Minimum and maximum domination numbers $\gamma(C_5 \boxtimes C_n)$ for sample values of n .

4.6 Chapter Summary

This chapter explored the modification to the algorithm by Livingston and Stout [55] to accommodate any Cartesian product $G \square H$. Furthermore, its use in determining the domination number of the generalized Cartesian product $G \boxtimes H$ is illustrated. The basic algorithm of Livingston and Stout was explained in Section 4.2 using $K_2 \square P_n$ as an example. Section 4.3 introduced a general framework for evaluating the domination number of $G \square H$ for a fixed graph G and any H . The problem of determining $\gamma(G \square H)$ was shown to be equivalent to a conditional, weighted homomorphism problem. Section 4.4 provided an algorithm to determine $\gamma(G \square T)$ for any tree T , which has polynomial time complexity for trees of bounded maximum degree. Lastly, Section 4.5 discussed how the general framework for $G \square H$ may be modified to accommodate the generalized Cartesian product $G \boxtimes H$, and provided applications of the algorithm to some product graphs.

Chapter 5

Planarity

5.1 Introduction

In this chapter, the study diverts from the main topic of domination to explore the planarity of generalized Cartesian products. Demoucron, Malgrange and Pertuiset [16] provided a simple polynomial-time algorithm to test the planarity of a graph G . Although more efficient algorithms exist (such as the linear-time algorithm by Hopcroft and Tarjan [69]), this algorithm is discussed in Section 5.2 and used to establish conditions on when the generalized Cartesian product $P_m \boxtimes P_n$ is planar in Section 5.3. In 1967 Chartrand and Harary [9] characterized planar generalized prisms πG if G is 2-connected. In 1972 Nebeský [60] characterized planar generalized prisms of paths. These results are discussed in Section 5.3, followed by an investigation into the planarity of generalized Cartesian products.

Recall that if a graph G of order n is planar, then $|E(G)| \leq 3n - 6$. This leads to the following obvious condition for when the graph H is a path and the generalized Cartesian product $G \boxtimes H$ is nonplanar.

Proposition 5.1.1 *If $|E(G)| \geq \frac{5}{2}|V(G)|$, then $G \boxtimes H$ is nonplanar for any nontrivial path*

H and any permutation π of $V(G)$.

Proof: Let G and H be of order m and n respectively. If $G \boxplus H$ is planar, then $n|E(G)| + m|E(H)| = |E(G \boxplus H)| \leq 3mn - 6$. If H is a path of size $n - 1 \geq 1$, then $|E(G)| \leq 2m + \frac{m}{n} - \frac{6}{n}$. Since $n \geq 2$, $|E(G)| \leq \frac{5}{2}m - \frac{6}{n} < \frac{5}{2}m$. ■

It is assumed throughout that the graph in question is 2-connected, since a graph is planar if and only if all of its blocks are planar. Some preliminary definitions are provided, generally following the terminology in [2] and [58].

Definition 5.1.1 Let H be a proper subgraph of G . A maximal nontrivial component B of $G - E(H)$ with the property that any two vertices in B are connected by a path internally disjoint from H , is called a bridge of H in G .

As an example, the graph shown in Figure 5.1 has proper subgraph H the cycle induced by $\{v_1, v_2, \dots, v_5\}$, and bridges B_1 and B_2 , the subgraphs with vertex sets $\{v_2, v_4, v_6, v_7, v_8\}$ and $\{v_3, v_4, v_9, v_{10}, v_{11}, v_{12}\}$, and edges shown as dark and dashed lines respectively.

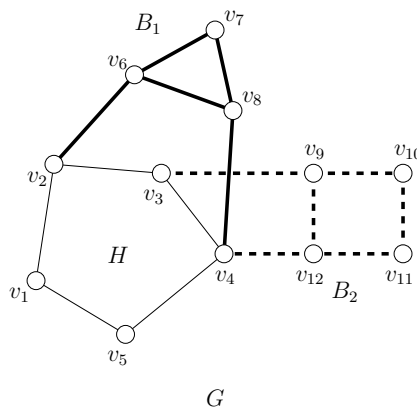


Figure 5.1: B_1 and B_2 are bridges of $H = \langle \{v_1, v_2, \dots, v_5\} \rangle$.

Definition 5.1.2 If B is a bridge of H in G , then the elements of $V(B) \cap V(H)$ are called

the vertices of attachment (of B to H). The elements of $V(B) - V(H)$ are called the internal vertices of B with respect to H .

Referring to the example shown in Figure 5.1, vertices v_2 and v_4 are vertices of attachment of B_1 to H , while vertices v_6 , v_7 and v_8 are internal vertices of B_1 .

Definition 5.1.3 Let G be a planar graph and H a subgraph of G . A planar embedding \hat{H} of H is said to be G -admissible if there exists a planar embedding \hat{G} of G such that $\hat{H} \subseteq \hat{G}$. In this case, \hat{H} is extended to \hat{G} .

As an example, consider the complete graph on vertices $\{v_1, v_2, \dots, v_5\}$. Let $G = K_5 - \{v_2v_4\}$ and $H = G - \{v_4v_5\}$. Figure 5.2 shows two embeddings, \hat{H}_1 and \hat{H}_2 , of H . The former is G -admissible, since clearly the edge v_4v_5 can be embedded to produce a planar embedding of G , but the latter is not G -admissible.

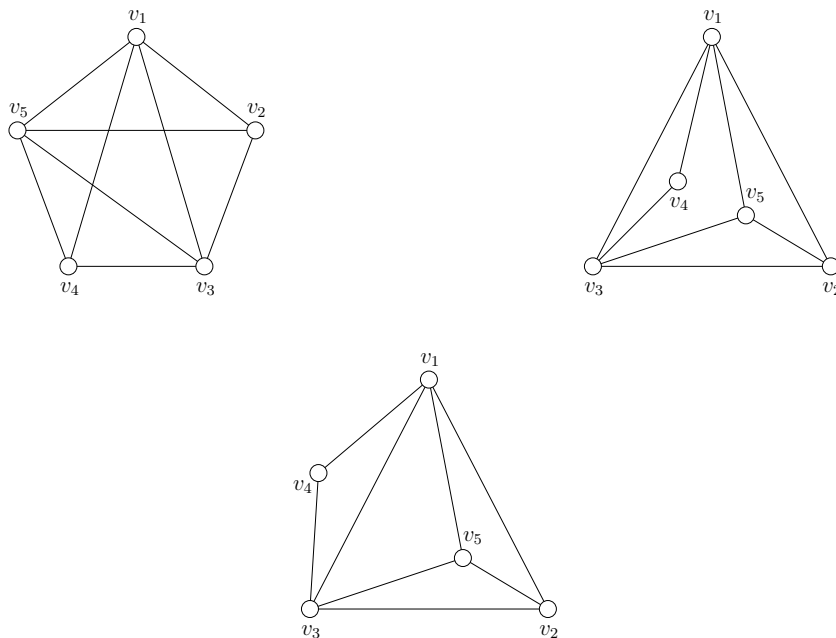


Figure 5.2: The graph $G = K_5 - \{v_2v_4\}$ with two embeddings, \hat{H}_1 and \hat{H}_2 , of $H = G - \{v_4v_5\}$.

Definition 5.1.4 For a bridge B of H in G , a path in B whose end-vertices are vertices of attachment of B , is called a bridge-path (in B) of H .

For the graph G in Figure 5.1, the path $P : v_2, v_6, v_8, v_4$ is a bridge-path (in B_1) of H in G .

Definition 5.1.5 Let \hat{H} be G -admissible. An admissible face f of a bridge B (or a bridge-path P in B) in \hat{H} , is one in which B (or P) can be embedded to produce a new G -admissible embedding. The set of admissible faces of B in \hat{H} is denoted $F(B, \hat{H})$.

Referring to the graph in Figure 5.1, with partial embedding \hat{H} and bridges B_1 and B_2 , both bridges (and all their bridge-paths) have both faces of the embedded cycle \hat{H} as admissible faces.

5.2 A Planarity Testing Algorithm

Let G be a 2-connected graph with cycle C . Demoucron, Malgrange and Pertuiset [16] suggested a polynomial-time algorithm to test the planarity of G . Starting with the embedding \hat{G}_1 of the cycle C , an appropriate bridge-path is added at each step to extend the partial embedding \hat{G}_i to \hat{G}_{i+1} . Given the G -admissible embedding \hat{G}_i , the number of admissible faces of a bridge is considered. If a bridge has 0 admissible faces, then clearly \hat{G}_i cannot be extended and G is nonplanar. If a bridge has exactly one admissible face, then the bridge is embedded into that face immediately. However, if every bridge has at least 2 admissible faces, then an arbitrary choice may be made for any one of them. These possibilities form the basis of an algorithm by Rubin [64], which considers bridge-paths sequentially to select the next partial embedding. This is stated in Algorithm 5.2.1.

Given the partial embedding \hat{G}_i of G (specified by the graph G_i and its faces F), the subalgorithm `FINDPATH()` searches for a long bridge-path to embed next. This is done by

Algorithm 5.2.1: ISPLANAR(G, C)

comment: $\left\{ \begin{array}{l} \text{Returns } \mathbf{true} \text{ if } G \text{ is planar.} \\ C \text{ is a cycle in } G, \text{ which is assumed to be 2-connected.} \end{array} \right.$

external $\left\{ \begin{array}{l} \text{REMOVEEDGES}(), \text{FACES}(), \text{ISEMPTY}(), \\ \text{EDGES}(), \text{FINDPATH}(), \text{EMBED}() \end{array} \right.$

$G_i \leftarrow C$

$G \leftarrow \text{REMOVEEDGES}(G, C)$

$F \leftarrow \text{FACES}(C)$

while **not** ISEMPTY(EDGES(G))

$\left\{ \begin{array}{l} \text{facelist}, P \leftarrow \text{FINDPATH}(G_i, G, F) \\ \text{if ISEMPTY}(\text{facelist}) \\ \text{do } \left\{ \begin{array}{l} \text{then return (false)} \\ \text{else } \left\{ \begin{array}{l} \text{face} \leftarrow \text{facelist}(1) \\ G_i, G, F \leftarrow \text{EMBED}(P, G_i, G, F, \text{face}) \end{array} \right. \end{array} \right. \end{array} \right.$

return (**true**)

way of a depth-first search through the bridges, and the algorithm returns the longest path P so obtained, as well as the set *facelist* of admissible faces of P . If a path that does not have any admissible faces is encountered, *facelist* is set to \emptyset . Also, as soon as a path with exactly one admissible face is obtained, this path is returned along with the relevant face. The subalgorithm EMBED() proceeds to take the path P and embed it into the admissible face *face* (the first one in *facelist*, since the choice is arbitrary) of the partial embedding \hat{G}_i . It updates G_i and F to represent the current embedding \hat{G}_{i+1} , as well as deletes the newly embedded edges from G .

The following observation is made before presenting a proof of the algorithm.

Observation 5.2.1 *Let G be planar graph and H a proper subgraph of G .*

1. If \hat{H} is G -admissible, then $|F(B, \hat{H})| \geq 1$ for any bridge B of \hat{H} in G .
2. If \hat{H} is not G -admissible, then there exists a bridge-path of H that has no admissible faces in \hat{H} .
3. If \hat{H} is not G -admissible, then there exist vertices $u, v \in V(H)$ and a closed Jordan curve K in \hat{H} such that
 - (a) $u \in \text{int}(K)$, $v \in \text{ext}(K)$ and
 - (b) G has a u - v path Q , and this path contains a bridge-path of \hat{H} in G . ■

Proposition 5.2.1 *A 2-connected graph G is planar if and only if Algorithm 5.2.1 returns true.*

Proof: If the algorithm returns **true** then a planar embedding of G is obtained. Suppose that G is planar. Let $\hat{G}_1, \hat{G}_2, \dots, \hat{G}_r$ denote the sequence of partial embeddings produced by the algorithm, with \hat{G}_1 being the initial cycle. It is shown that every embedding \hat{G}_i is G -admissible.

Since G_1 is a cycle, its planar embedding \hat{G}_1 is unique and therefore G -admissible. Suppose \hat{G}_i is G -admissible for some i such that $1 \leq i \leq r - 1$. Then $E(G) \setminus E(G_i) \neq \emptyset$. Let \mathcal{S} denote the nonempty set of bridges of \hat{G}_i in G . Then $F(B, \hat{G}_i) \neq \emptyset$ for every $B \in \mathcal{S}$.

If there exists a bridge B such that $|F(B, \hat{G}_i)| = 1$, let P be any bridge-path in B of \hat{G}_i . Since \hat{G}_i is G -admissible, the embedding \hat{G}_{i+1} obtained from \hat{G}_i by embedding P in the one admissible face, is a planar embedding and also G -admissible.

Otherwise, $|F(B, \hat{G}_i)| \geq 2$ for every bridge $B \in \mathcal{S}$. Then any bridge-path of \hat{G}_i in G has at least two admissible faces. The algorithm acts on the premise that any bridge-path P can be embedded into any of its admissible faces, and \hat{G}_{i+1} so obtained is G -admissible. Let $f(P)$ denote the set of admissible faces of a bridge-path P . Suppose, to the contrary, that there

exist a bridge-path P and an admissible face $f_1 \in f(P)$ such that \hat{G}_{i+1} is not G -admissible. Then \hat{G}_{i+1} cannot be extended to a planar embedding of G . By Observation 5.2.1(3), there exist vertices $u, v \in V(G_{i+1})$ and a closed Jordan curve K in \hat{G}_{i+1} , induced by edges of \hat{G}_{i+1} , such that

- $u \in \text{int}(K)$, $v \in \text{ext}(K)$ and
- G has a u - v path Q that is a bridge-path of \hat{G}_{i+1} in G .

Furthermore, since \hat{G}_i is G -admissible, P lies on the curve K , and therefore $u, v \in V(G_i)$. Also, Q is a bridge-path of \hat{G}_i in G . It follows that Q has only one admissible face in \hat{G}_i , namely the face $f_1 \in f(P)$. This contradiction shows that any bridge-path can be embedded into any of its admissible faces to produce a G -admissible partial embedding. ■

As an example, let G be the graph shown in Figure 5.3. Algorithm 5.2.1 is used to sequentially embed the edges of G , starting with \hat{G}_1 , the cycle shown in Figure 5.4. This figure illustrates the first steps the algorithm follows to produce a planar embedding \hat{G} of G . Due to the fact that a depth-first search is employed to determine the next bridge-path to embed, the last steps of the algorithm are only concerned with embedding single edges. In this example, the edges v_2v_7 , v_3v_8 , v_5v_9 and v_6v_7 are embedded, in this order, to produce the planar embedding \hat{G} illustrated in Figure 5.3.

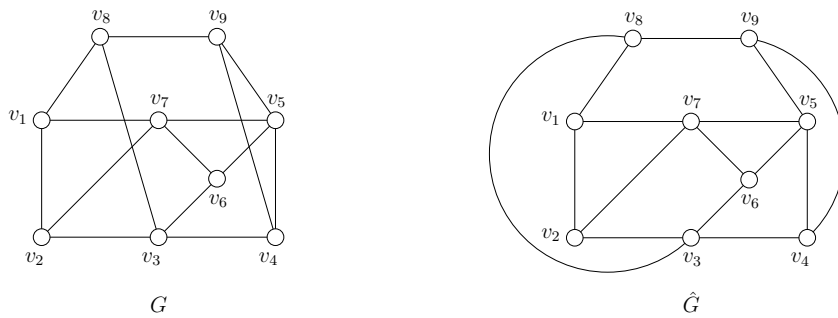


Figure 5.3: A graph G with planar embedding \hat{G} .

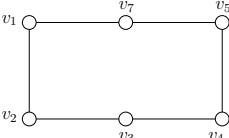
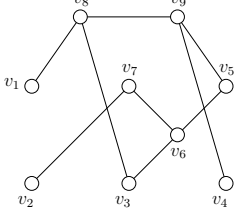
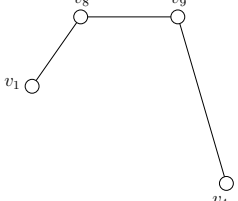
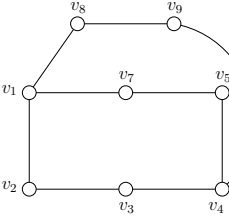
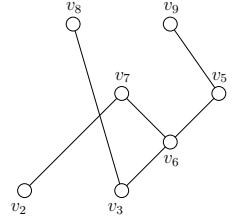
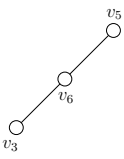
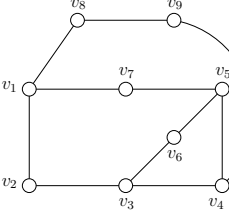
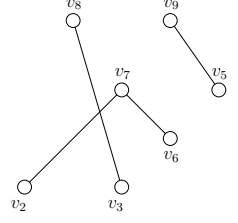
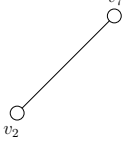
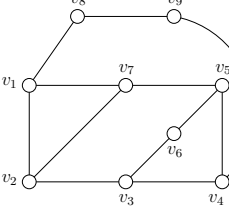
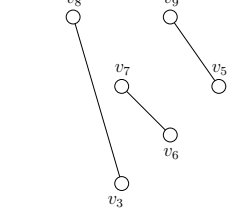

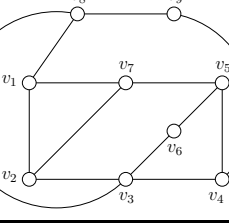
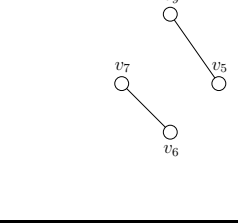
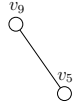
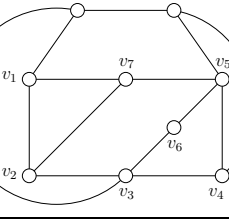
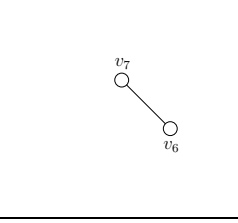
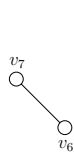
Partial embedding \hat{G}_i	The graph induced by $E(G) - E(\hat{G}_i)$	Selected bridge-path
		
		
		
		
		
		

Figure 5.4: Partial embeddings produced by Algorithm 5.2.1 for the graph G shown in Figure 5.3.

5.3 Planarity Conditions

For 2-connected graphs G , Chartrand and Harary [9] provided a characterization of planar generalized prisms πG . Recall that the automorphism group of a canonically labelled cycle of length m is the dihedral group D_m . Observe that G is outerplanar if πG is planar, since it is impossible to embed all the edges between the two G -layers otherwise. Suppose that G has vertex set $\{v_1, v_2, \dots, v_m\}$ and an outerplanar embedding with exterior cycle C canonically labelled. Embed a copy G_1 of G with interior face bounded by C , and embed a second copy G_2 of G inside this face, but with an outerplanar embedding as illustrated in Figure 5.5. (The shaded areas indicate the other embedded edges of G_1 and G_2 respectively.) The matching edges can be embedded if and only if the matching corresponds to a permutation $\pi \in D_m$. This result is stated next.

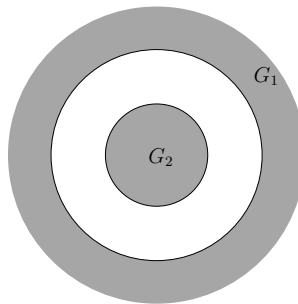


Figure 5.5: An embedding of the two copies G_1 and G_2 of the outerplanar graph G in πG .

Proposition 5.3.1 [9] *For a 2-connected graph G of order m , πG is planar if and only if G is outerplanar and, if π is defined with respect to a canonical labelling of the exterior cycle of an outerplanar embedding of G , then $\pi \in D_m$. ■*

The following corollary is applicable to an arbitrarily labelled graph G .

Corollary 5.3.1 *Let G be a 2-connected outerplanar graph of order m , C_m a canonically labelled cycle of order m , and let C denote the exterior cycle of an outerplanar embedding*

of G . Then πG is planar if and only if there exists an isomorphism $\phi : C \rightarrow C_m$ such that $\phi^{-1}\pi\phi \in D_m$. ■

Nebeský [60] provided the following characterization for planar generalized prisms πP_m . For three distinct integers i, j and k , let $\text{med}(i, j, k)$ denote the property that either $i < j < k$ or $k < j < i$. Let the vertices of the P_m -layers be canonically labelled $\{v_{i,1} : i = 1, 2, \dots, m\}$ and $\{v_{i,2} : i = 1, 2, \dots, m\}$ respectively, and suppose there exist integers $1 < i < j < k < m$ such that $\text{med}(\pi(i), \pi(j), \pi(i-1))$. Algorithm 5.2.1 can be used to examine possible embeddings of πP_m . If $\pi(i) < \pi(j) < \pi(i-1)$, let C be the cycle containing $v_{i,1}, v_{j,1}, v_{\pi(j),2}, v_{\pi(i),2}$, as illustrated in Figure 5.6(a). Every bridge-path of C has two admissible faces. The bridge-path containing $v_{i,1}, v_{i-1,1}, v_{\pi(i-1),2}, \dots, v_{\pi(j),2}$ can be embedded in the exterior of C , as shown in Figure 5.6(a). If, in addition to $\pi(i) < \pi(j) < \pi(i-1)$, $\text{med}(\pi(k), \pi(j), \pi(k+1))$ also holds, then it can be verified easily that not all bridge-paths can be embedded sequentially according to Algorithm 5.2.1. For the case $\pi(i-1) < \pi(j) < \pi(i)$, let C be the cycle containing $v_{i-1,1}, v_{i,1}, \dots, v_{j,1}, v_{\pi(j),2}, \dots, v_{\pi(i-1),2}$, as illustrated in Figure 5.6(b). Similarly, the bridge-path containing $v_{i,1}, v_{\pi(i),2}, \dots, v_{\pi(j),2}$ can be embedded in the exterior of C , as shown in Figure 5.6(b). It again follows that $\text{med}(\pi(k), \pi(j), \pi(k+1))$ cannot hold, since otherwise not all bridge-paths can be embedded sequentially according to Algorithm 5.2.1.

Proposition 5.3.2 [60] *The generalized prism πP_m , $m \geq 5$, is planar if and only if for any $1 < i < j < k < m$, at most one of $\text{med}(\pi(i), \pi(j), \pi(i-1))$ or $\text{med}(\pi(k), \pi(j), \pi(k+1))$ holds.* ■

When considering the planarity of generalized Cartesian products, it is shown below that $G \boxtimes H$ is nonplanar if each of the graphs G and H is 2-connected (of order at least 3, including the 3-cycle). Recall that for any two vertices u and v in a 2-connected graph, there exist two internally disjoint u - v paths, and therefore a cycle containing u and v .

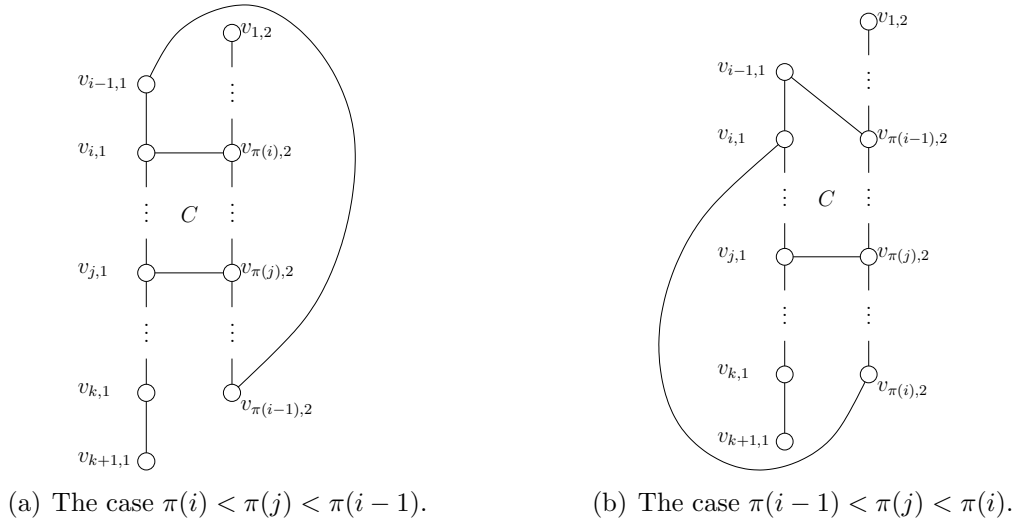


Figure 5.6: A partial embedding produced by Algorithm 5.1 when $\text{med}(\pi(i), \pi(j), \pi(i-1))$.

Proposition 5.3.3 *If G and H are both 2-connected graphs, then $G \boxtimes H$ is nonplanar for any permutation π of $V(G)$.*

Proof: Let $V(G) = \{v_1, v_2, \dots, v_m\}$ and $V(H) = \{u_1, u_2, \dots, u_n\}$. Also, let P_H and Q_H denote two internally disjoint u_1 – u_n paths and let $C_H = P_H \cup Q_H$ denote the corresponding cycle containing u_1 and u_n in H . For each $j = 1, 2, \dots, n$, there exist two internally disjoint $(\pi^{j-1}(v_1), u_j)$ – $(\pi^{j-1}(v_m), u_j)$ paths, say $P_G^{(j)}$ and $Q_G^{(j)}$, in the j^{th} G -layer G_j of $G \boxtimes H$. Let $C_G^{(j)} = P_G^{(j)} \cup Q_G^{(j)}$ denote the corresponding cycle containing $(\pi^{j-1}(v_1), u_j)$ and $(\pi^{j-1}(v_m), u_j)$. Also, observe that for $i \in \{1, m\}$, the set $\{(\pi^{j-1}(v_i), u_j) : u_j \in V(C_H)\}$ induces a cycle in the corresponding H -layer of $G \boxtimes H$. For $i \in \{1, m\}$, let $P_H^{(i)}$ and $Q_H^{(i)}$ denote two internally disjoint (v_i, u_j) – $(\pi^{n-1}(v_i), u_n)$ paths, with $C_H^{(i)} = P_H^{(i)} \cup Q_H^{(i)}$. Using Algorithm 5.2.1, it is shown next that there does not exist a planar embedding of $G \boxtimes H$:

Without loss of generality in the above notation, suppose that the P -paths defined have order at least that of the corresponding Q -paths. Let C denote the cycle induced in $G \boxtimes H$ by $P_G^{(1)} \cup P_H^{(m)} \cup P_G^{(n)} \cup P_H^{(1)}$.

Suppose $G \boxtimes H$ is planar and consider the possible embedding of three bridge-paths:

- (i) the bridge-path $Q_H^{(1)}$, with vertices of attachment (v_1, u_1) and $(\pi^{n-1}(v_1), u_n)$;
- (ii) the bridge-path $P_G^{(2)}$, with vertices of attachment $(\pi(v_1), u_2)$ and $(\pi(v_m), u_2)$;
- (iii) the bridge-path $Q_G^{(2)}$, with vertices of attachment $(\pi(v_1), u_2)$ and $(\pi(v_m), u_2)$.

Note that any bridge-path, including those in (i) – (iii), has both the interior and exterior of C as an admissible face. Following Algorithm 5.2.1, the partial embedding obtained from embedding any bridge path next, results in an admissible embedding. Without loss of generality, suppose $Q_H^{(1)}$ is embedded in the exterior of C . Then both $P_G^{(2)}$ and $Q_G^{(2)}$ must be embedded in the interior of C . Let (w, u_2) be an internal vertex of $P_G^{(2)}$. It is easily verified that for any embedding of $P_G^{(2)}$ and $Q_G^{(2)}$ in the interior of C , either

- a bridge-path containing the edge $(\pi^{-1}(w), u_1)(w, u_2)$ has no admissible face, or
- a bridge-path containing the edge $(w, u_2)(\pi(w), u_3)$ has no admissible face.

This contradiction implies that there does not exist a planar embedding of $G \boxtimes H$. ■

For the remainder of this section the generalized Cartesian product $P_m \boxtimes P_n$, with both paths canonically labelled, is considered. When it is convenient to do so, π is viewed as an element of S_m acting on the subscripts of the vertex labels v_1, v_2, \dots, v_m of P_m . In other words, $\pi(v_i) = v_j$ will be written as $v_{\pi(i)} = v_j$. In the case of the generalized Cartesian product $P_m \boxtimes P_n$, Algorithm 5.2.1 gives rise to the necessary condition stated in Proposition 5.3.1. The following observation follows from Algorithm 5.2.1.

Observation 5.3.1 *Let \hat{H} be a G -admissible partial embedding of G and let B be a bridge-path of H . If $|F(B, \hat{H})| = 1$, then any subpath of B that contains a vertex of attachment may be embedded into the admissible face of B such that the resulting embedding is G -admissible.* ■

Theorem 5.3.1 *If $P_m \boxtimes P_n$ is planar, $n \geq 4$, then for any distinct $a, b \in \{1, 2, \dots, m\}$ and any $j = 2, 3, \dots, n - 1$,*

$$|\pi^j(a) - \pi^j(b)| \in \{|\pi^{j+1}(a) - \pi^{j+1}(b)|, m - |\pi^{j+1}(a) - \pi^{j+1}(b)|\}.$$

Proof: Let $V(P_m \boxtimes P_n) = \{v_{i,j} : i = 1, 2, \dots, m, j = 1, 2, \dots, n\}$ and $a, b \in \{1, 2, \dots, m\}$, $a < b$. Also, let the P_m -layers be denoted G_j and $V_j = V(G_j)$, $j = 1, 2, \dots, n$. Consider Algorithm 5.2.1 with initial cycle C induced by the vertex sets $\{v_{\pi^{j-1}(a),j} : j = 1, 2, \dots, n\} \cup \{v_{\pi^{j-1}(b),j} : j = 1, 2, \dots, n\} \cup \{v_{a,1}, v_{a+1,1}, \dots, v_{b,1}\} \cup \{v_{\pi^{n-1}(a),n}, \dots, v_{\pi^{n-1}(b),n}\}$. The vertices from each P_m -layer are sequentially embedded.

Considering the intersection of the cycle C and the P_m -layer G_j , $j \in \{1, 2, \dots, n\}$, the vertices of G_j are partitioned into sets

$$\begin{aligned} V_j^{(l)} &= \{v_{i,j} : i > \max\{\pi^{j-1}(a), \pi^{j-1}(b)\}\}, \\ V_j^{(c)} &= \{v_{i,j} : \min\{\pi^{j-1}(a), \pi^{j-1}(b)\} < i < \max\{\pi^{j-1}(a), \pi^{j-1}(b)\}\}, \text{ and} \\ V_j^{(u)} &= \{v_{i,j} : i < \min\{\pi^{j-1}(a), \pi^{j-1}(b)\}\}. \end{aligned}$$

Let \hat{H}_1 denote the unique planar embedding of C . Since any bridge-path of \hat{H}_1 in G has two admissible faces, embed the path induced by $V_2^{(c)}$ into the interior face of C . Then the exterior of C is the only admissible face of any bridge-path containing $V_2^{(u)}$ [similarly $V_2^{(l)}$], since otherwise not all the edges joining G_2 and G_3 can be embedded. By Observation 5.3.1, the subpaths induced by $V_2^{(u)}$ and $V_2^{(l)}$ are embedded in this face. Let \hat{H}_2 denote this G -admissible partial embedding and note that it contains all the vertices of G_2 . The embedding of $V_2^{(c)}$ in \hat{H}_2 is illustrated in Figure 5.7.

It is shown next that $|V_j^{(c)}|$ is equal to either $|V_{j+1}^{(c)}|$ or $|V_{j+1}^{(u)}| + |V_{j+1}^{(l)}|$, $j = 2, 3, \dots, n - 2$.

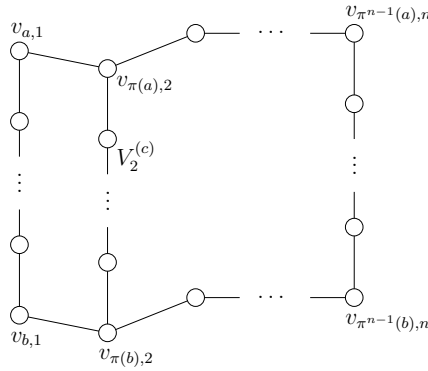


Figure 5.7: The planar embedding of \hat{H}_2 .

Assume that \hat{H}_j is an admissible embedding, with all P_m -layers G_2, G_3, \dots, G_j already embedded, and exactly one of (a) $V_j^{(c)}$ or (b) $V_j^{(u)} \cup V_j^{(l)}$ embedded in the interior of C , $j = 2, 3, \dots, n - 2$. These cases are illustrated in Figure 5.8. Consider case (a), divided into two subcases.

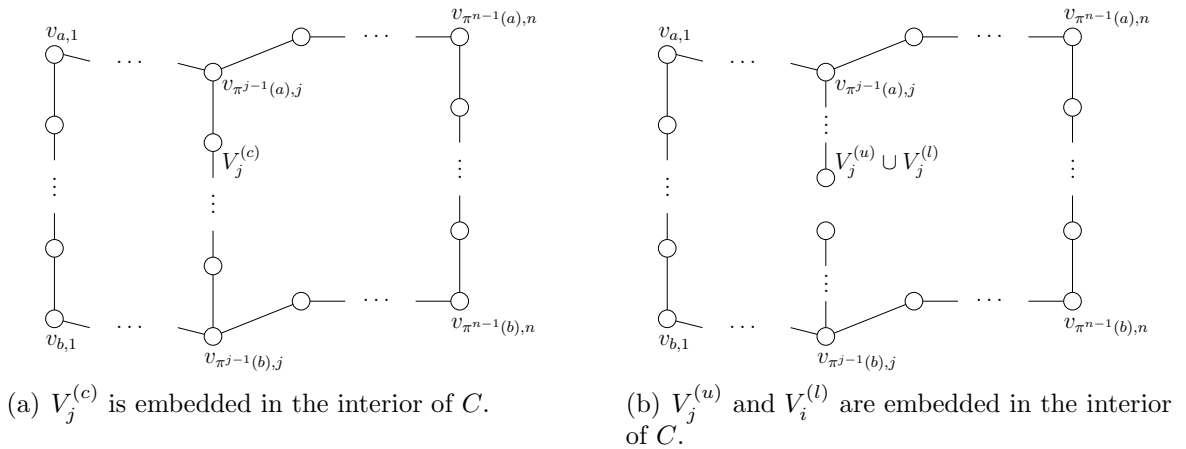


Figure 5.8: The two possible cases for \hat{H}_j , when considering the part of G_j embedded inside C .

Subcase 1: $v_{\pi(i),j+1} \in V_{j+1}^{(c)}$ for some $v_{i,j} \in V_j^{(c)}$. Then the bridge-paths $P : v_{i,j}, v_{\pi(i),j+1}, \dots, v_{\pi^j(a),j+1}$ and $Q : v_{\pi(i),j}, \dots, v_{\pi^j(b),j+1}$ each has exactly one admissible face, in the interior of C . By Observation 5.3.1, embed the path induced by $V_{j+1}^{(c)}$ in this face. As was the case with embedding G_2 , the paths induced by $V_{j+1}^{(u)}$ and $V_{j+1}^{(l)}$ have only the exterior of C as

admissible face. Let \hat{H}_{j+1} denote the admissible partial embedding obtained by embedding G_j accordingly. The embedding of $V_{j+1}^{(c)}$ in \hat{H}_{j+1} is shown in Figure 5.9. (The edge $v_{i,j}v_{\pi(i),j+1}$ is shown as a dashed line, since it is not part of the embedding \hat{H}_{j+1} .) It follows that there is a matching between $V_j^{(c)}$ and $V_{j+1}^{(c)}$ in $P_m \boxtimes P_n$, so that $|V_j^{(c)}| = |V_{j+1}^{(c)}|$.

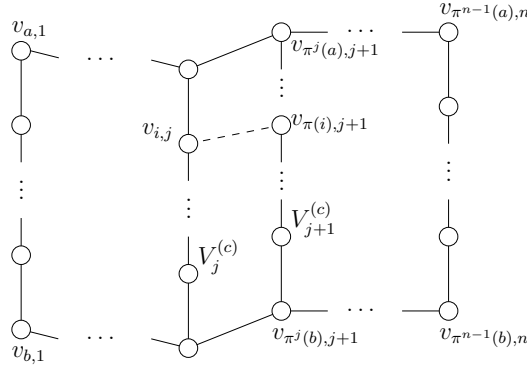


Figure 5.9: The embedding in case (a) when $v_{\pi(i),j} \in V_{j+1}^{(c)}$ for some $v_{i,j} \in V_j^{(c)}$.

Subcase 2: $v_{\pi(i),j+1} \notin V_{j+1}^{(c)}$ for any $v_{i,j} \in V_j^{(c)}$. Then the bridge-paths $P : v_{\pi^{-1}(1),j}, v_{1,j+1}, \dots, v_{\pi^j(a),j+1}$ and $Q : v_{\pi^{-1}(m),j}, v_{m,j+1}, \dots, v_{\pi^j(b),j+1}$ each has exactly one admissible face, in the interior of C . By Observation 5.3.1, embed the paths induced by $V_{j+1}^{(u)}$ and $V_{j+1}^{(l)}$ in this face. Once again, the bridge-path induced by $V_{j+1}^{(c)}$ have only the exterior of C as admissible face. Let \hat{H}_{j+1} denote the admissible partial embedding obtained by embedding G_j accordingly. The embedding of $V_{j+1}^{(u)}$ and $V_{j+1}^{(l)}$ in \hat{H}_{j+1} is shown in Figure 5.10. (The edges $v_{\pi^{-1}(1),j}v_{1,j+1}$ and $v_{\pi^{-1}(m),j}v_{m,j+1}$ are shown as dashed lines, since they are not part of the embedding \hat{H}_{j+1} .) It follows that there is a matching between $V_j^{(c)}$ and $V_{j+1}^{(u)}, V_{j+1}^{(l)}$ in $P_m \boxtimes P_n$, so that $|V_j^{(c)}| = |V_{j+1}^{(u)}| + |V_{j+1}^{(l)}|$.

In a similar manner, case (b) leads to two subcases. Subcase 1 allows for $v_{\pi(i),j} \in V_{j+1}^{(c)}$ for some $v_{i,j} \in V_j^{(u)} \cup V_j^{(l)}$, while subcase 2 considers the possibility that $v_{\pi(i),j} \notin V_{j+1}^{(c)}$ for any $v_{i,j} \in V_j^{(u)} \cup V_j^{(l)}$. The former leads to $|V_j^{(u)}| + |V_j^{(l)}| = |V_{j+1}^{(c)}|$, while the latter results in $|V_j^{(u)}| + |V_j^{(l)}| = |V_{j+1}^{(u)}| + |V_{j+1}^{(l)}|$.

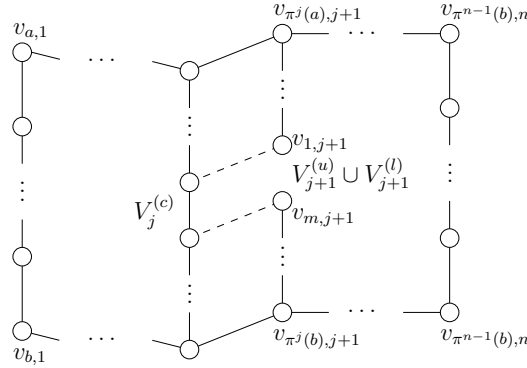


Figure 5.10: The embedding in case (a) when $v_{\pi(i),j} \notin V_{j+1}^{(c)}$ for any $v_{i,j} \in V_j^{(c)}$.

In all cases, either $|V_j^{(c)}| = |V_{j+1}^{(u)}| + |V_{j+1}^{(l)}|$ or $|V_j^{(c)}| = |V_{j+1}^{(c)}|$. The result follows by induction on j . ■

If $P_m \boxtimes P_n$ is planar, the proof of Proposition 5.3.1 suggests a planar embedding of the graph. Sufficient conditions are established next for the generalized Cartesian product $P_m \boxtimes P_n$ to be planar. Each pair of consecutive P_m -layers in the product induces a subgraph isomorphic to the generalized prism πP_m . For $v, w \in V(P_m)$, say that π has a *planar matching* with respect to (P_m, v, w) if the edges of the K_2 -layers of πP_m (also called the matching edges) can be embedded under certain additional restrictions involving v and w . When considering the generalized Cartesian product $P_m \boxtimes P_n$, establishing a suitable sequence of planar matchings will yield a planar embedding of the graph.

As before, let $P_m \boxtimes P_n$ have vertex set $\{v_{i,j} : i = 1, 2, \dots, m, j = 1, 2, \dots, n\}$ and let $a, b \in \{1, 2, \dots, m\}$, $a < b$. Also, let the P_m -layers of $P_m \boxtimes P_n$ be denoted G_j and $V_j = V(G_j)$, $j = 1, 2, \dots, n$. Consider Algorithm 5.2.1 with initial cycle C induced by the vertex sets $\{v_{\pi^{j-1}(a),j} : j = 1, 2, \dots, n\} \cup \{v_{\pi^{j-1}(b),j} : j = 1, 2, \dots, n\} \cup \{v_{a,1}, v_{a+1,1}, \dots, v_{b,1}\} \cup \{v_{\pi^{n-1}(a),n}, \dots, v_{\pi^{n-1}(b),n}\}$. For $j = 1, 2, \dots, n$, define the sets $V_j^{(l)}$, $V_j^{(c)}$ and $V_j^{(u)}$ as in the proof of Theorem 5.3.1. Embed $V_j^{(u)} \cup V_j^{(l)}$ in the exterior of C for $j \in \{1, n\}$, denoting this embedding by \hat{H}_1 , and establish a sequence of planar matchings so that for each

State label	Sets embedded inside C
s_{1a}	$V_1^{(c)}$ and $V_2^{(c)}$
s_{1b}	$V_1^{(c)}$ and $V_2^{(u)} \cup V_2^{(l)}$
s_2	$V_j^{(c)}$ and $V_{j+1}^{(c)}$
s_3	$V_j^{(c)}$ and $V_{j+1}^{(u)} \cup V_{j+1}^{(l)}$
s_4	$V_j^{(u)} \cup V_j^{(l)}$ and $V_j^{(c)}$
s_5	$V_j^{(u)} \cup V_j^{(l)}$ and $V_{j+1}^{(u)} \cup V_{j+1}^{(l)}$
s_{6a}	$V_{n-1}^{(c)}$ and $V_n^{(c)}$
s_{6b}	$V_{n-1}^{(u)} \cup V_{n-1}^{(l)}$ and $V_n^{(c)}$

Table 5.1: The states describing a planar embedding of $P_m \boxtimes P_n$.

$j \in \{2, 3, \dots, n-1\}$, exactly one of the sets $V_j^{(c)}$ or $V_j^{(u)} \cup V_j^{(l)}$ is embedded in the interior of C , as described below. First define 8 states, regarding an embedding of consecutive P_m -layers, as explained in Table 5.1.

Let D denote the directed graph shown in Figure 5.11, with vertices the states listed in Table 5.1. It will be shown that any directed walk W of order $n-1$ in D , with initial vertex s_{1a} or s_{1b} and terminal vertex s_{6a} or s_{6b} and satisfying property **P**, corresponds to a planar embedding of $P_m \boxtimes P_n$.

(**P**) If state s_i is the j^{th} vertex in W , then π has a planar matching of type i (defined below) with respect to $(P_m, v_{\pi^{j-1}(a)}, v_{\pi^{j-1}(b)})$, $j = 1, 2, \dots, n$.

Let G_1 and G_2 denote the respective P_m -layers of the generalized prism πP_m . A permutation π has a *planar matching of type 1a* with respect to (P_m, v, w) if the graph πP_m can be embedded as shown in Figure 5.12(a) without any edge-crossings, such that all matching edges are embedded above the line of the path G_2 . (The P_m -layers G_1 and G_2 are drawn horizontally instead of vertically.) Similarly, a permutation π has a *planar matching of type 6a* with respect to (P_m, v, w) if the graph πP_m can be embedded as shown in Figure 5.12(b) without any edge-crossings, such that all matching edges are embedded above the line of the path G_1 . In both cases, the vertices v and w partition the vertex set of the P_m -layer

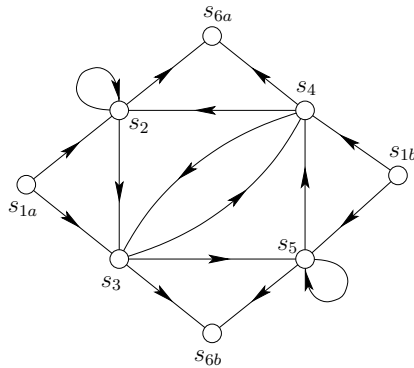


Figure 5.11: The state-transition graph D that allows for a planar embedding of $P_m \boxtimes P_n$.

G_1 into sets denoted $V_1^{(u)}$, $V_1^{(c)}$ and $V_1^{(l)}$, and similarly for the layer G_2 , as illustrated.

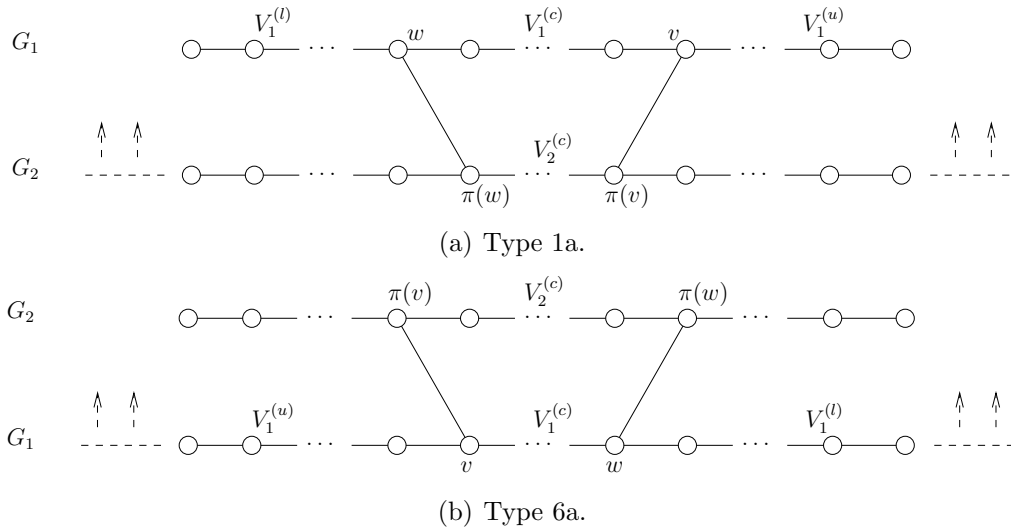


Figure 5.12: Planar matchings of types 1a and 6a.

A permutation π has a *planar matching of type 1b* with respect to (P_m, v, w) if the graph πP_m can be embedded as in Figure 5.13(a) without any edge-crossings, where no matching edge intersects the shaded areas. Similarly, a permutation π has a *planar matching of type 6b* with respect to (P_m, v, w) if the graph πP_m can be embedded as shown in Figure 5.13(b) without any edge-crossings, where no matching edge intersects the shaded areas. In both cases, the vertices v and w partition the vertices of the P_m -layer G_1 into sets denoted $V_1^{(u)}$, $V_1^{(c)}$ and $V_1^{(l)}$, and similarly for the layer G_2 , as illustrated.

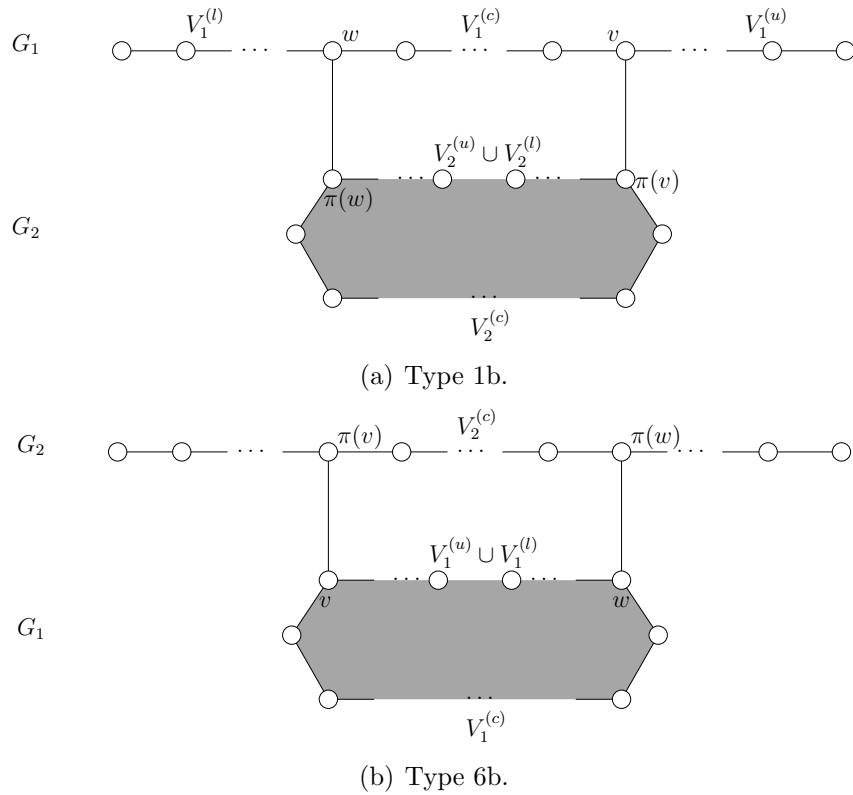


Figure 5.13: Planar matchings of types 1b and 6b.

A permutation π has a *planar matching of type 2* with respect to (P_m, v, w) if the graph πP_m can be embedded as shown in Figure 5.14(a), without any edge-crossings, where no matching edge intersects the shaded areas. Similarly, a permutation π has a *planar matching of type 5* with respect to (P_m, v, w) if the graph πP_m can be embedded as shown in Figure 5.14(b) without any edge-crossings, where no matching edge intersects the shaded areas. Again the vertices v and w partition the vertex set of the P_m -layer G_1 into sets denoted $V_1^{(u)}$, $V_1^{(c)}$ and $V_1^{(l)}$, and similarly for the layer G_2 .

A permutation π has a *planar matching of type 3* with respect to (P_m, v, w) if the graph πP_m can be embedded as shown in Figure 5.15(a), without any edge-crossings, with all matching edges embedded below the line of the path G_1 , where no edges intersect the shaded area. Similarly, a permutation π has a *planar matching of type 4* with respect to (P_m, v, w) if the graph πP_m can be embedded as shown in Figure 5.15(b) without any

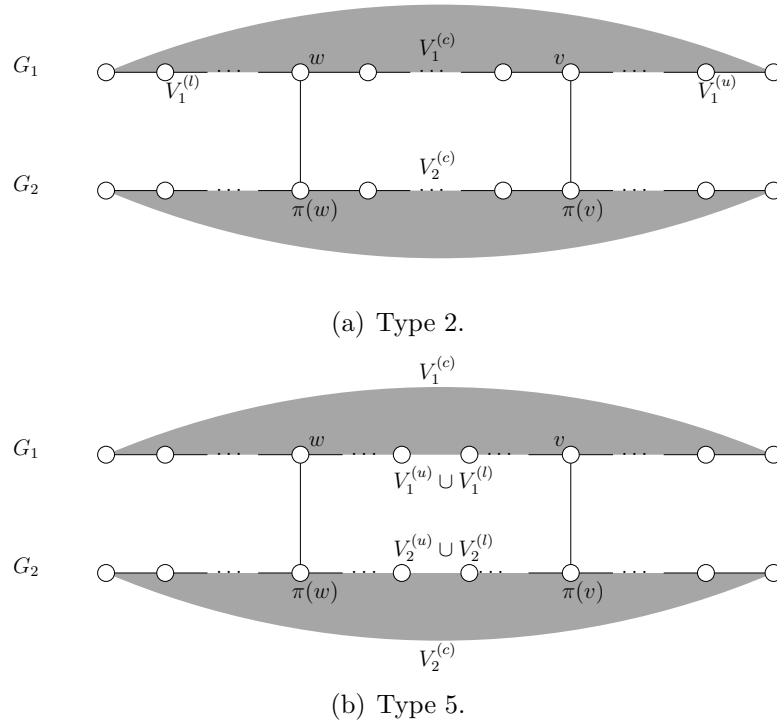


Figure 5.14: Planar matchings of types 2 and 5.

edge-crossings, with all matching edges embedded below the line of the path G_2 , where no edges intersect the shaded area. In both cases, the vertices v and w partition the vertex set of the P_m -layer G_1 into sets denoted $V_1^{(u)}$, $V_1^{(c)}$ and $V_1^{(l)}$, and similarly for the layer G_2 , as illustrated.

A sufficient condition for $P_m \boxtimes P_n$ to be planar is now stated, referring to the state-transition graph D in Figure 5.11. Suppose π allows for a directed walk W of order $n - 1$ in the state-transition graph D , with initial vertex s_{1a} or s_{1b} and terminal vertex s_{6a} or s_{6b} , that satisfies property **P**. Then clearly there exists a sequence of embeddings \hat{H}_j of $P_m \boxtimes P_j$ that are G -admissible, $j = 2, 3, \dots, n$. Since the walk W satisfies property **P**, each successive copy G_j can be embedded, along with its edges to the previous copy, according to the appropriate type of planar matching. At each step, the partial embedding can be extended to include the next P_m -layer, ultimately resulting in an embedding of G .

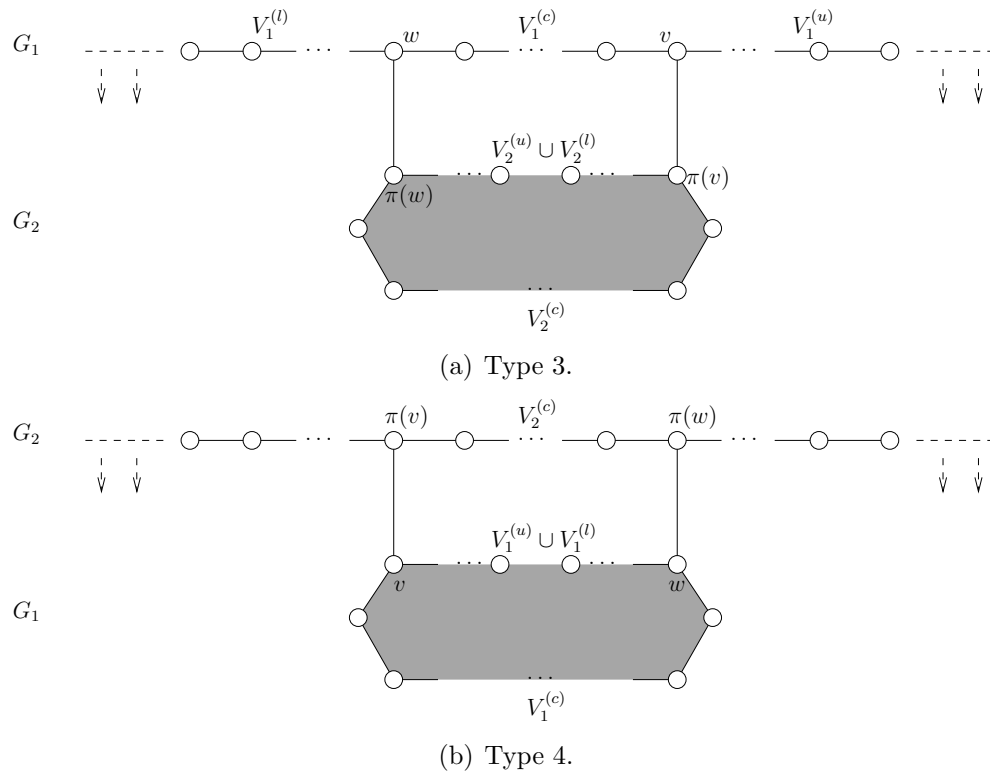


Figure 5.15: Planar matchings of types 3 and 4.

Theorem 5.3.2 *If there exists a directed walk W of order $n-1$ in the state-transition graph D , with initial vertex s_{1a} or s_{1b} and terminal vertex s_{6a} or s_{6b} , that satisfies property \mathbf{P} , then $P_m \boxtimes P_n$ is planar, $n \geq 3$. ■*

It remains to characterize permutations π which allow planar matchings of types 1a, 1b, 6a and 6b. The first of these types of matchings is discussed, while it is noted that the other types follow a similar argument. For the sake of simplicity, assume that $\pi(v) < \pi(w)$ in the canonical ordering of $V(P_m)$, and that the vertices of πP_m are partitioned as illustrated in Figure 5.16. For the sake of convenience, consider the sets $V_j^{(u)}$, $V_j^{(c)}$ and $V_j^{(l)}$ to be ordered sequences $s_j(u)$, $s_j(c)$ and $s_j(l)$ respectively, so as to efficiently reference the vertices. For example, the vertex $s_j^{(u)}(i)$ denotes the i^{th} vertex from the left in $V_j^{(u)}$ in Figure 5.16, $j = 1, 2$.

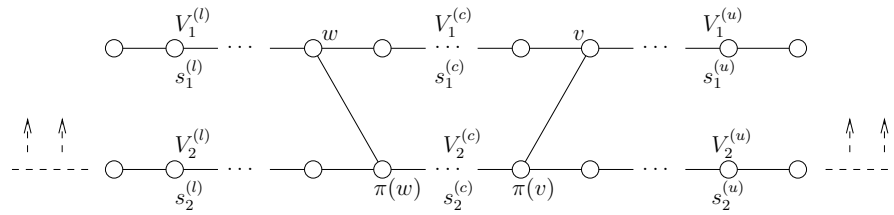


Figure 5.16: A partitioning of the vertices of πP_m .

To determine whether or not the permutation π has a planar matching of type 1a, the matching edges are embedded iteratively, and it is observed that the resulting situation is equivalent to some other planar matching on a generalized prism of lower order. Ultimately, the remaining edges can only be embedded in a trivial manner. The permutation π then has a planar matching of type 1a if and only if the matching edges of πP_m can be embedded systematically in this fashion.

Let $s_2^{(c)}$ be a sequence of length k . If $k \neq 0$, then the sequence matches with some subsequence of $s_1^{(c)}$. Let this sequence of indices be given by j_1, j_2, \dots, j_k . To ensure that the edges can be embedded without any edge-crossings, $s_1^{(c)}(j_{i_1}) < s_1^{(c)}(j_{i_2})$ if and only if $s_2^{(c)}(i_1) < s_2^{(c)}(i_2)$ for any $i_1, i_2 \in \{1, 2, \dots, k\}$. Examining the remaining edges is equivalent to examining a planar matching of type 1a in the smaller generalized prism illustrated in Figure 5.17.

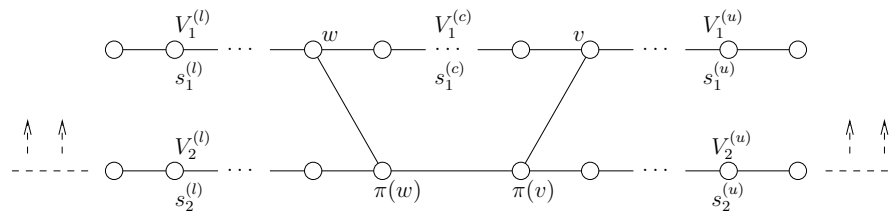


Figure 5.17: A partitioning of the vertices of πP_m , where $s_2^{(c)}$ is empty.

This smaller case is now examined, considering four subcases based on the adjacency of the vertex $s_1^{(u)}(1)$.

Case 1: The vertex $s_1^{(u)}(1)$ is adjacent to $s_2^{(u)}(1)$. This edge is embedded uniquely, and examining the remaining edges is equivalent to examining a planar matching of type 1a on a smaller generalized prism, illustrated in Figure 5.17.

Case 2: The vertex $s_1^{(u)}(1)$ is adjacent to $s_2^{(u)}(i)$ for some $i > 1$. First define two additional types of planar matchings. A permutation π has a *planar matching of type 7a* with respect to (P_m, v) if the graph πP_m can be embedded as shown in Figure 5.18(a) without any edge-crossings, with all matching edges embedded above the line of the path G_2 . Similarly, a permutation π has a *planar matching of type 7b* with respect to (P_m, v, w) if the graph πP_m can be embedded as shown in Figure 5.18(b) without any edge-crossings, with all matching edges embedded above the line of the path G_2 . Where applicable, the vertices v and w partition the vertex set of the P_m -layer G_1 into sets $V_1^{(u)}$, $V_1^{(c)}$ and $V_1^{(l)}$, and similarly for the layer G_2 . The edge $s_1^{(u)}(1)s_2^{(u)}(i)$ is embedded such that $V_1^{(u)} - \{s_1^{(u)}(1)\}$ is in the interior of the face induced by $v, \pi(v), \dots, s_2^{(u)}(i), s_1^{(u)}(1)$. Examining the remaining edges is equivalent to examining a planar matching of both types 7a and 7b, on smaller graphs, as illustrated in Figure 5.18.

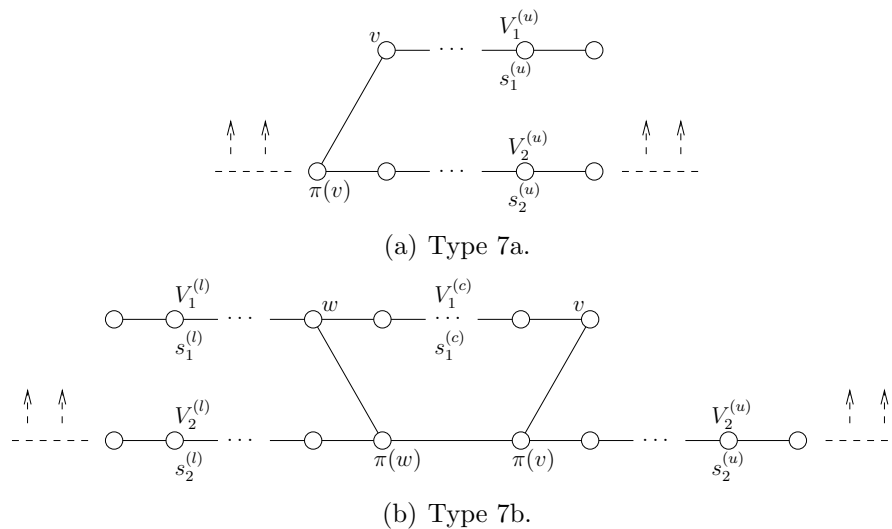


Figure 5.18: Planar matchings of types 7a and 7b.

Case 3: The vertex $s_1^{(u)}(1)$ is adjacent to $s_2^{(l)}(i)$ for some i . First define an additional type of planar matching. A permutation π has a *planar matching of type 7c* with respect to (P_m, v) if the graph πP_m can be embedded as shown in Figure 5.19 without any edge-crossings, with all matching edges embedded above the line of the path G_2 . The vertex v partitions the vertex set of the P_m -layer G_1 into sets $V_2^{(u)}$, $V_2^{(l)}$ and $V_1^{(u)}$. The edge $s_1^{(u)}(1)s_2^{(l)}(i)$ is embedded uniquely, and examining the remaining edges is equivalent to examining a planar matching of both types 7c, and 7b with $V_2^{(u)} = \emptyset$, on smaller graphs, as illustrated in Figure 5.19 and 5.18(b).

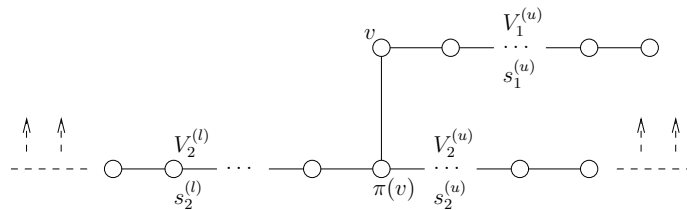


Figure 5.19: A planar matching of type 7c.

Case 4: If $V_1^{(u)} = \emptyset$, then a planar matching of type 7b, as illustrated in Figure 5.18, is examined.

It remains to further explore planar matchings of types 7a, 7b, 7c, and observe how they can be reduced to smaller cases. Examining whether or not a permutation π has a planar matching of type 7a, as illustrated in Figure 5.18(a), it is noted that $s_1^{(u)}(1)$ is adjacent to either $s_2^{(u)}(1)$ or $s_2^{(u)}(n_2)$, where n_2 denotes the length of the sequence $s_2^{(u)}$. In both cases, examining the remaining edges is equivalent to examining a planar matching of type 7a on a smaller graph.

To determine whether or not π has a planar matching of type 7b, as illustrated in Figure 5.18(b), let n_1 and n_2 denote the lengths of $s_1^{(l)}$ and $s_2^{(l)}$ respectively. In the case where $s_1^{(l)}(n_1)$ is adjacent to $s_2^{(l)}(n_2)$, examining the remaining edges is equivalent to examining a planar matching of type 7b on a smaller graph. Suppose the vertex $s_1^{(l)}(n_1)$ is adjacent to

$s_2^{(l)}(k)$ for some $k < n_2$. A permutation π has a *planar matching of type 7d* with respect to (P_m, v, w) if the graph πP_m can be embedded as shown in Figure 5.20 without any edge-crossings, with all matching edges embedded above the line of the path G_2 . The edge $s_1^{(l)}(n_1)s_2^{(l)}(k)$ is embedded such that $V_1^{(l)} - \{s_1^{(l)}(n_1)\}$ is in the interior of the face induced by $w, \pi(w), \dots, s_2^{(l)}(k), s_1^{(l)}(n_1)$. Examining the remaining edges is equivalent to examining a planar matching of both types 7a and 7d, on smaller graphs, as illustrated in Figure 5.18(a) and 5.20. Lastly, in the case where $s_1^{(l)}(n_1)$ is adjacent to $s_2^{(u)}(k)$ for some k , examining the remaining edges is equivalent to examining a planar matching of both types 7c, and 7d with $V_2^{(l)} = \emptyset$, on smaller graphs, as illustrated in Figure 5.19 and 5.20.

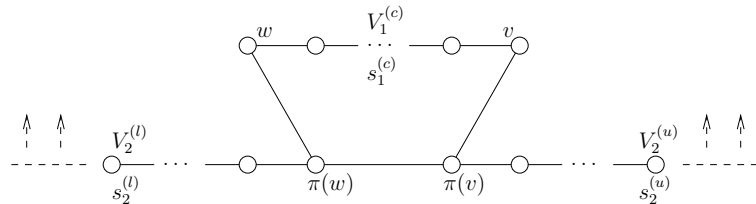


Figure 5.20: A planar matching of type 7d.

Examining whether or not a permutation π has a planar matching of type 7c, as illustrated in Figure 5.19, it is noted that if $s_2^{(l)}$ is empty, then examining the remaining edges is equivalent to examining a planar matching of type 7a, as illustrated in Figure 5.18(a). Otherwise, $s_2^{(l)}$ must match with the last part of $s_1^{(u)}$ in reversed order, reducing the remaining edges to be matched according to a planar matching of type 7a.

A permutation π has a planar matching of type 7d, as illustrated in Figure 5.20, if and only if the first (left) part of $s_1^{(c)}$ matches with $s_2^{(l)}$ in reversed order, and the last (right) part of $s_1^{(c)}$ matches with $s_2^{(u)}$ in reversed order.

A small example of a generalized product that satisfies the sufficient conditions for planarity stated in Proposition 5.3.2 is provided next. Let the vertex set of $P_5 \boxtimes P_5$ be denoted $\{v_{i,j} : i = 1, 2, \dots, 5, j = 1, 2, \dots, 5\}$ as before and $\pi = (v_1, v_2)(v_3, v_5)$. This product is

shown in Figure 5.21. Figure 5.22 shows that $\pi = (v_1, v_2)(v_3, v_5)$ has a planar matching of type 1a with respect to (P_5, v_1, v_5) , a planar matching of type 3 with respect to (P_5, v_2, v_5) , a planar matching of type 4 with respect to (P_5, v_1, v_5) , and a planar matching of type 6a with respect to (P_5, v_2, v_5) . The permutation π therefore allows for a walk $W : s_{1a}, s_3, s_4, s_{6a}$ of order of length 3 in the state-transition graph D (Figure 5.11) that satisfies property **P**, so that $P_5 \boxtimes P_5$ is planar, with a planar embedding illustrated in Figure 5.23.

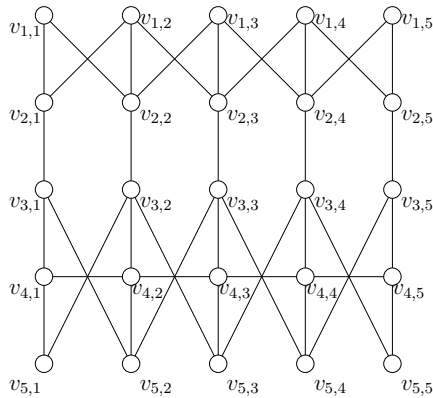


Figure 5.21: The generalized Cartesian product $P_5 \boxtimes P_5$, with $\pi = (v_1, v_2)(v_3, v_5)$.

5.4 Chapter Summary

In this chapter, the planarity of generalized Cartesian products was explored. If both G and H are 2-connected graphs, then the generalized Cartesian product $G \boxtimes H$ is nonplanar. A simple polynomial-time planarity testing algorithm by Demoucron, Malgrange and Per-tuiset [16] was discussed in Section 5.2. The algorithm was used to establish conditions on the planarity of $P_m \boxtimes P_n$ in Section 5.3.

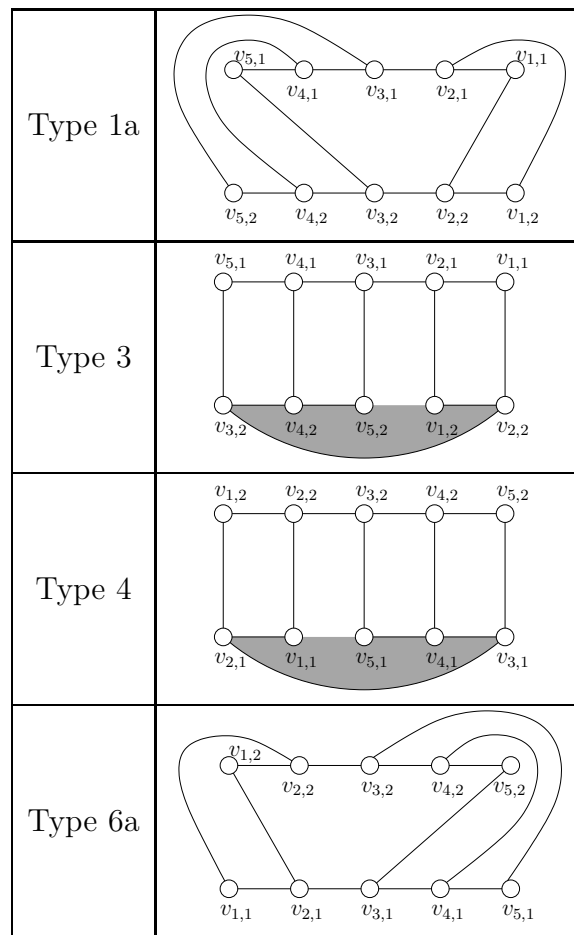


Figure 5.22: Planar matchings of $\pi = (v_1, v_2)(v_3, v_5)$.

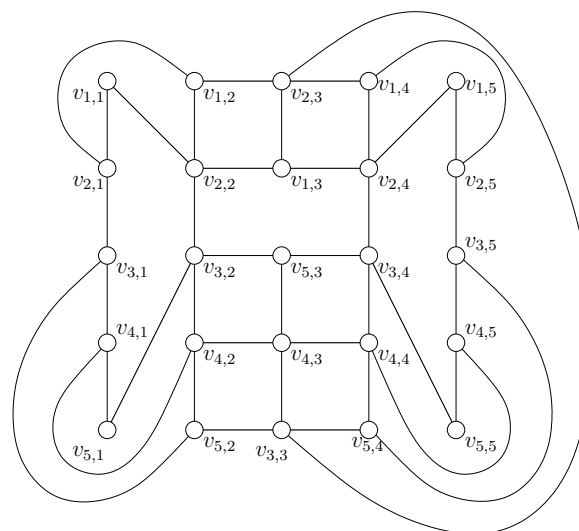


Figure 5.23: A planar embedding of $P_5 \square P_5$, with $\pi = (v_1, v_2)(v_3, v_5)$.

Chapter 6

Conclusion

A summary of the work contained in this document is provided in Section 6.1. In Section 6.2, various open problems that arose from the study are summarised and highlighted for further work. Finally, the definition of the generalized Cartesian product may be generalised in various ways, while still maintaining the so-called layer partition property. The chapter concludes with one such generalization, thereby suggesting a possibly sensible framework for future research on generalizing the Cartesian product.

6.1 Thesis Summary

The potential truth of Vizing's conjecture gives rise to an investigation of similar inequalities for graph products that generalize the Cartesian product. In this dissertation a first step towards investigating a generalized Cartesian product that incorporates structural properties of both the Cartesian product of two graphs as well as the generalized prism of a graph was taken. The domination number of such a generalized Cartesian product was explored, with the objective to lay the foundation for further research in this area.

The generalized Cartesian product graph was defined in Chapter 1, where it was related to

both the Cartesian product and the generalized prism graph. A survey of the literature on the domination of Cartesian products was conducted in Section 1.2, and progress towards proving Vizing's conjecture was highlighted. Other graph products that may be considered as possible generalizations of the Cartesian product were discussed, in an attempt to place the new generalized Cartesian product definition into context.

Chapter 2 initiated the study of the generalized Cartesian product. Conditions on the isomorphism of two generalized Cartesian products were explored in Section 2.2. The characterization for natural isomorphisms by Lee and Sohn [54] for G -permutation graphs over H was applied to this graph product and various corollaries were discussed. Section 2.3 explored the diameter of the generalized Cartesian product, comparing it to that of the corresponding Cartesian product graph. Conditions were discussed under which the respective diameters are equal. Lastly, Section 2.4 explored the validity of an inequality similar to Vizing's conjecture for Cartesian products. Various results were provided to illustrate the relationship between the domination number of a generalized Cartesian product and the domination numbers of the respective graphs.

Chapter 3 explored graphs that attain equality in the general bounds for the domination number of the Cartesian product and generalized Cartesian product. For any graph G and $n \geq 2$, $\min\{|V(G)|, \gamma(G) + n - 2\} \leq \gamma(G \square K_n) \leq n\gamma(G)$. A graph G is called a consistent fixer if $\gamma(G \square K_n) = \gamma(G) + n - 2$ for each n such that $2 \leq n < |V(G)| - \gamma(G) + 2$. This and other classes of Cartesian fixers were characterized in Section 3.2. A graph attaining equality in the stated upper bound on $\gamma(G \square K_n)$ is called a Cartesian n -multiplier. This class of graphs was characterized in Section 3.3. Concerning the generalized Cartesian product, $\gamma(G \boxtimes K_n) \leq n\gamma(G)$ for any graph G , permutation π and $n \geq 2$. A graph attaining equality in the upper bound for all π is called a universal multiplier. Such graphs were characterized in Section 3.4 similar to [5] in the case of generalized prisms. A similar problem for the product $G \boxtimes C_n$ was considered in Section 3.5, where conditions on a graph

being a so-called cycle multiplier were provided. A graph attaining equality in the lower bound $\gamma(G \boxtimes H) \geq \gamma(G)$ for some permutation π is called a π - H -fixer. Section 3.6 conducted a brief investigation into the existence of universal H -fixers, i.e. graphs that are π - H -fixers for some H and all permutations π of $V(G)$, and it was shown that no such graphs exist when $n \geq 3$.

Chapter 4 explored how the efficient algorithm by Livingston and Stout [55] (for determining $\gamma(G \square P_n)$) may be modified to accommodate any Cartesian product $G \square H$. Furthermore, its use in determining the domination number of the generalized Cartesian product $G \boxtimes H$ was illustrated. The basic algorithm was explained in Section 4.2 by way of an example. Section 4.3 introduced a general framework for evaluating the domination number of $G \square H$ for a fixed graph G and any H . The problem of determining $\gamma(G \square H)$ was shown to be equivalent to a conditional, weighted homomorphism problem. Section 4.4 provided an algorithm to determine $\gamma(G \square T)$ for any tree T , and observed that it is polynomial for trees of bounded maximum degree. Lastly, Section 4.5 discussed how the general framework for $G \square H$ may be modified to accommodate the generalized Cartesian product $G \boxtimes H$. The results were illustrated by presenting an algorithm to determine $\gamma(G \boxtimes T)$.

The study diverted from the main topic of domination to investigate the planarity of the generalized Cartesian product graph in Chapter 5. If both G and H are 2-connected graphs, then $G \boxtimes H$ is nonplanar. A simple polynomial-time planarity testing algorithm by Demoucron, Malgrange and Pertuiset [16] was discussed in Section 5.2. The algorithm was adapted to establish conditions on the planarity of $P_m \boxtimes P_n$ in Section 5.3.

6.2 Further Work

Throughout this study, a number of unresolved questions arose. These open problems are summarized in this section.

As discussed in Section 1.2.3, Lee and Sohn [54] defined a G -permutation graph over H with respect to ϕ , denoted $H \bowtie^\phi G$, as a graph product that generalizes the notion of both graph bundles and generalized prisms. They provided a characterization for when two permutation graphs over a graph are isomorphic by a natural isomorphism. Consider two generalized Cartesian products $G \boxtimes H$ and $G \boxtimes H$, with vertex sets $\{(v_i, u_j) : i = 1, 2, \dots, m, j = 1, 2, \dots, n\}$, and let G_j denote the G -layer corresponding to u_j in the respective graphs, with vertex set $V_j = V(G_j)$. The product $G \boxtimes H$ is said to be isomorphic to $G \boxtimes H$ by a natural isomorphism ϕ if for any $i \in \{1, 2, \dots, n\}$, $\phi(V_i) = V_j$ for some $j \in \{1, 2, \dots, n\}$. In Section 2.2, Theorem 2.2.2 provided a characterization (similar to the result by Lee and Sohn [54]) for when two generalized Cartesian products are isomorphic by a natural isomorphism. The characterization was followed by various corollaries regarding the natural isomorphism of two generalized Cartesian products.

Question 6.2.1 *Is it possible to establish conditions for a non-natural isomorphism between two generalized Cartesian products $G \boxtimes H$ and $G \boxtimes H$?*

In Section 2.2, it was observed that the set of generalized Cartesian product graphs $G \boxtimes H$ depends on the labelling of $V(H)$. As an example, let H be the path of order 3, with vertices canonically labelled u_1, u_2, u_3 , and let H' be obtained from H by interchanging the labels u_1 and u_2 . The generalized Cartesian products $G \boxtimes H$ and $G \boxtimes H'$, with $G = P_3$ and $\pi = (v_1, v_2)$, were shown in Figure 2.5. It is verified easily that $G \boxtimes H' \not\cong G \boxtimes H$ for any permutation α of $V(G)$.

Question 6.2.2 *Is it possible to establish conditions under which different labellings of $V(H)$ change the domination number of the generalized product $\gamma(G \boxtimes H)$?*

In Section 2.4, it was observed that the complete graph K_m satisfies a Vizing inequality with respect to any graph H for any permutation π . The generalized Cartesian product between

a cycle and the corona of a graph was used to illustrate that a Vizing inequality does not always hold for this product. Furthermore, it was shown that $\gamma(G \boxtimes H) \geq \gamma(G)\rho_2(H)$ for any permutation π and that for some π , $\gamma(G \boxtimes H) \geq \rho_2(G)\gamma(H)$. In other words, a Vizing inequality holds between two trees for all permutations, and there exist permutations π (other than the identity permutation) such that a tree satisfies a Vizing inequality with respect to any graph.

Question 6.2.3 *Do there exist families of noncomplete graphs G that satisfy a Vizing inequality with respect to any graph H and for any permutation π ?*

Question 6.2.4 *Is it possible to characterize graphs G for which there exist a graph H and permutation π of $V(G)$ such that $\gamma(G \boxtimes H) < \gamma(G)\gamma(H)$?*

Proposition 2.4.8 showed that if $\gamma(\pi G) \geq k$, then $\gamma(G \boxtimes H) \geq \frac{k}{2} \frac{\delta(H)}{\Delta(H)^2} |V(H)|$ for any permutation π of $V(G)$. If H is r -regular with an efficient γ -set, then $\delta(H) = \Delta(H) = r$ and $|V(H)| = (r+1)\gamma(H)$, so that $\gamma(G \boxtimes H) \geq \frac{k}{2}\gamma(H)$ in this case. It follows that any universal doubler satisfies a Vizing inequality with respect to such H for any permutation, since $k = 2\gamma(G)$ yields $\gamma(G \boxtimes H) \geq \gamma(G)\gamma(H)$.

Question 6.2.5 *Is it possible to prove that $\gamma(G \boxtimes H) \geq c\gamma(G)\gamma(H)$ for some constant c ?*

Section 3.5 considered the generalized Cartesian product $G \boxtimes C_n$. A graph G is called a universal n -cycle-multiplier if $\gamma(G \boxtimes C_n) = n\gamma(G)$ for every permutation π of $V(G)$. By constructing a family of graphs, a necessary condition for a graph to be a universal n -cycle-multiplier was noted in Observation 3.5.2.

Question 6.2.6 *Is it possible to characterize universal cycle-multipliers for some simple graph classes by way of a statement similar to Observation 3.5.2?*

Both universal multipliers and universal cycle-multipliers concerned the domination of the generalized Cartesian product of a graph G with a vertex transitive graph (the complete graph and the cycle respectively). Universal multipliers were characterized in Section 3.4, while Observation 3.5.2 suggested a possible characterization for universal cycle-multipliers that belong to some simple classes of graphs.

Question 6.2.7 *Is it possible to characterize graphs G for which $\gamma(G \boxtimes H) = n\gamma(G)$, where $H \neq K_n$ is some vertex transitive graph?*

Chapter 5 investigated the planarity of generalized Cartesian products. In Section 5.3, Proposition 5.3.3 established that, if G and H are both 2-connected graphs, then $G \boxtimes H$ is nonplanar for any permutation π of $V(G)$.

Question 6.2.8 *Is it true that if G and H each contain a 2-connected subgraph, then for any permutation π of $V(G)$, $G \boxtimes H$ is nonplanar?*

It is easy to verify that $C_m \square P_n$ is planar, and therefore so is $C_m \boxtimes P_n$ for any $\pi \in \text{Aut}(C_m)$. So one of the graphs G or H may be 2-connected and the generalized Cartesian product $G \boxtimes H$ may still be planar for some permutation π of $V(G)$.

Question 6.2.9 *Is it possible to establish conditions under which one of G or H is 2-connected and $G \boxtimes H$ is planar for some π ?*

The majority of Section 5.3 concerned the planarity of $P_m \boxtimes P_n$. A sufficient condition was established on the planarity of this generalized Cartesian product. Restricting the study to the product of two graphs that do not contain any 2-connected subgraphs, one could also consider the planarity of the generalized product between two trees instead of paths.

Question 6.2.10 *Is it possible to characterize trees T_1, T_2 and permutations π such that $T_1 \boxtimes T_2$ is planar?*

6.3 A Further Generalization

As a possibly sensible framework for future research, a graph product that generalizes Definition 1.1.3 is proposed in this section.

Denote the graph obtained from G by replacing each label v_i with $\pi(v_i)$, by $\pi(G)$. Following the usual notation for functions, $\pi^k(G)$ is recursively defined by $\pi^k(G) = \pi(\pi^{k-1}(G))$ (π^0 is simply the identity permutation $\mathbf{1}$). The G -layers of the generalized Cartesian product $G \boxtimes H$ may be relabeled so that they correspond to the copies $\pi^0 G, \pi^{-1} G, \pi^{-2} G, \dots, \pi^{-(n-1)} G$ (in the first entries of the vertex labels). Denoting the vertex set by $V(G \boxtimes H) = \{(v_i, u_j) : i = 1, 2, \dots, m, j = 1, 2, \dots, n\}$, the product $G \boxtimes H$ of labelled graphs G and H may be defined as the graph with this vertex set, where $(v_i, u_j)(v_k, u_l) \in E(G \boxtimes H)$ if and only if (i) $u_j = u_l$ and $\pi^{j-1}(v_i)\pi^{j-1}(v_k) \in E(G)$, or (ii) $v_i = v_k$ and $w_j w_l \in E(H)$.

In the pursuit of generalizing Definition 1.1.3, a permutation σ of $V(H)$ may be specified as well. To this end, the product of $G \boxtimes H$ is defined as follows.

Definition 6.3.1 *For two labelled graphs G and H and permutations π, σ of $V(G), V(H)$ respectively, the product $G \boxtimes H$ is the graph with vertex set $V(G \boxtimes H) = V(G) \times V(H)$, where $(v_i, u_j)(v_k, u_l) \in E(G \boxtimes H)$ if and only if*

- (i) $u_j = u_l$ and $\pi^{j-1}(v_i)\pi^{j-1}(v_k) \in E(G)$, or
- (ii) $v_i = v_k$ and $\sigma^{i-1}(w_j)\sigma^{i-1}(w_l) \in E(H)$.

An informal discussion of this definition may be beneficial, since the labelling method for the vertex set differs from that of Definition 1.1.3. For the vertex $(v_i, u_j) \in V(G \boxtimes H)$, the first entry v_i corresponds to the vertex labelled $\pi^{j-1}(v_i)$ in the original labelling of G , while the second entry u_j corresponds to the vertex $\sigma^{i-1}(w_j)$ in the original labelling of H . When representing the product $G \boxtimes H$ as (relabelled) copies of G in the columns and

(relabelled) copies of H in the rows, the j^{th} G -layer (the column of vertices $\{(v_i, u_j) : i = 1, 2, \dots, m\}$) corresponds to the labelled graph $\pi^{-(j-1)}(G)$ in the first entries, so that π^{j-1} is an isomorphism from this layer to G . Adjacency requirement (i) in Definition 6.3.1 then states that two vertices (v_i, u_j) and (v_k, u_l) in the product $G \boxtimes H$ are adjacent if they appear in the same G -layer (column), and the vertices that the first entries $v_i, v_k \in V(\pi^{-(j-1)}(G))$ refer to in the original labelling of G , are adjacent (in other words $\pi^{j-1}(v_i)\pi^{j-1}(v_k) \in E(G)$). The second requirement may be interpreted in a similar manner by considering the permutation σ on the vertices of H in the rows of the representation.

Clearly the generalized Cartesian product is obtained in the case where $\sigma = \mathbf{1}$, and the product $G \boxtimes H$ still satisfies the layer-partition property stated in Section 1.1. As an example, consider $G \cong H \cong P_4$, where G and H are canonically labelled v_1, v_2, v_3, v_4 and u_1, u_2, u_3, u_4 respectively, Figure 6.1(a) shows the generalized product $G \boxtimes H$ with $\pi = (v_1, v_2, v_3)$ and $\sigma = \mathbf{1}$, while Figure 6.1(b) shows $G \boxtimes H$ with $\pi = (v_1, v_2, v_3)$ and $\sigma = (u_1, u_2)$. Recall that vertices (v_i, w_j) are labeled $v_{i,j}$ for convenience.

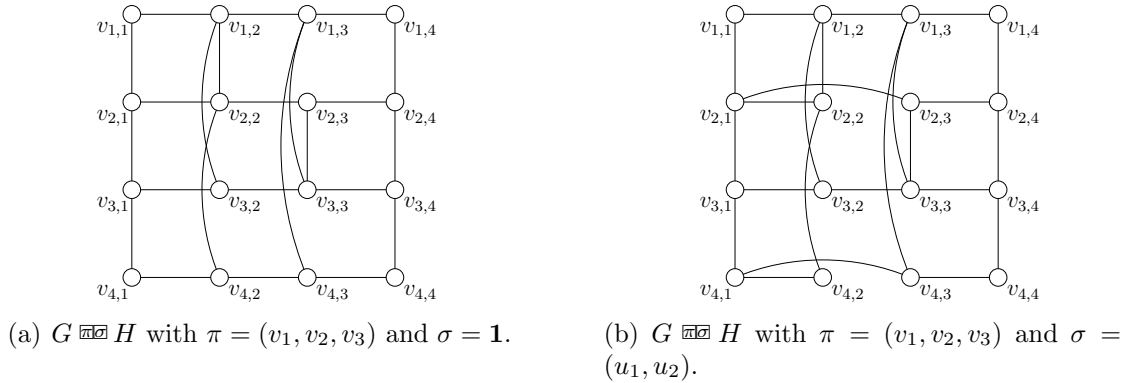


Figure 6.1: The product $G \boxtimes H$ of canonically labelled graphs G and H , $G \cong H \cong P_4$, with permutations (a) $\pi = (v_1, v_2, v_3)$, $\sigma = \mathbf{1}$ and (b) $\pi = (v_1, v_2, v_3)$, $\sigma = (u_1, u_2)$.

References

- [1] A.M. BARCALKIN AND L.F. GERMAN, *The external stability number of the Cartesian product of graphs*, Bul. Akad. Shtiintse RSS Moldoven., **1** (1979), 5-8, 94.
- [2] J.A. BONDY AND U.S.R. MURTY, *Graph Theory*, Springer, GTM 244, 2008.
- [3] B. BREŠAR, *On Vizing's conjecture*, Discuss. Math. Graph Theory, **21**(1) (2001), 5-11.
- [4] B. BREŠAR, M.A. HENNING AND S. KLAVŽAR, *On integer domination in graphs and Vizing-like problems*, Taiwanese J. Math., **10**(5) (2006), 1317-1328.
- [5] A.P. BURGER, C.M. MYNHARDT AND W.D. WEAKLEY, *On the domination number of prisms of graphs*, Discuss. Math. Graph Theory, **24**(2) (2004), 303-318.
- [6] A.P. BURGER AND C.M. MYNHARDT, *Regular graphs are not universal fixers*, Discrete Math., (2009), to appear.
- [7] T.Y. CHANG AND W.E. CLARK, *The domination numbers of the $5 \times n$ and $6 \times n$ grid graphs*, J. Graph Theory, **17**(1) (1993), 81-107.
- [8] T.Y. CHANG, W.E. CLARK AND E.O. HARE, *Domination numbers of complete grid graphs I*, Ars Combin., **38** (1994), 97-111.
- [9] G. CHARTRAND AND F. HARARY, *Planar permutation graphs*, Ann. Inst. H. Poincaré Sect. B (N.S.), **3** (1967), 433-438.

-
- [10] G. CHEN, W. PIOTROWSKI AND W. SHREVE, *A partition approach to Vizing's conjecture*, J. Graph Theory, **21**(1) (1996), 103-111.
- [11] R. CHÉRIFI, S. GRAVIER AND I. ZIGHEM, *Bounds on domination number of complete grid graphs*, Ars Combin., **60** (2001), 307-311.
- [12] W.E. CLARK AND S. SUEN, *An inequality related to Vizing's conjecture*, Electron. J. Combin., **7**(N4) (2000), (electronic).
- [13] W.E. CLARK, M.E.H. ISMAIL AND S. SUEN, *Applications of upper and lower bounds for the domination number to Vizing's conjecture*, Ars Combin., **69** (2003), 97-108.
- [14] E.J. COCKAYNE, E.O. HARE, S.T. HEDETNIEMI AND T.V. WIMER, *Bounds for the domination number of grid graphs*, Congr. Numer., **47** (1985), 217-228.
- [15] E.J. COCKAYNE, R.G. GIBSON AND C.M. MYNHARDT, *Claw-Free Graphs Are Not Universal Fixers*, Discrete Math., **309** (2009), 128-133.
- [16] G. DEMOUCRON, Y. MALGRANGE AND R. PERTUISET, *Graphes planaires: Reconnaissance et construction des représentations planaires topologiques*, Rev. Francais de Rech. Operationelle, **8** (1964), 34-47.
- [17] W. DORFLER, *On mapping graphs and permutation graphs*, Math Slovaca, **28**(3) (1978), 277-288.
- [18] M.H. EL-ZAHAR, S.M. KHAMIS AND K.M. NAZZAL, *On the domination number of the Cartesian product of the cycle of length n and any graph*, Discrete Appl. Math., **155**(4) (2007), 515-522.
- [19] M.H. EL-ZAHAR AND C.M. PAREEK, *Domination number of products of graphs*, Ars Combin., **31** (1991), 223-227.

-
- [20] M.H. EL-ZAHAR AND R.S. SHAHEEN, *The domination number of $C_8 \times C_n$ and $C_9 \times C_n$* , J. Egyptian Math. Soc., **7**(2) (1999), 151-166.
- [21] M.H. EL-ZAHAR AND R.S. SHAHEEN, *Bounds for the domination number of toroidal grid graphs*, J. Egyptian Math. Soc., **10**(2) (2002), 103-113.
- [22] R.J. FAUDREE, R.H. SCHELP AND W.E. SHREVE, *The domination number for the product of graphs*, Congr. Numer. **79** (1990), 29-33.
- [23] J.F. FINK, M.S. JACOBSON, L.F. KINCH AND J. ROBERTS, *On graphs having domination number half their order*, Period. Math. Hungar., **16**(4) (1985), 287-293.
- [24] D.C. FISHER, *Domination, fractional domination, 2-packing, and graph products*, SIAM J. Discrete Math., **7**(3) (1994), 493-498.
- [25] R.G. GIBSON AND C.M. MYNHARDT, *Universal Fixers and Regular Graphs*, preprint, 2006.
- [26] R.G. GIBSON, *Bipartite graphs are not universal fixers*, *Discrete Math.* **308** (2008), 5937-5943.
- [27] S. GRAVIER AND A. KHELLADI, *On the domination number of cross products of graphs*, *Discrete Math.*, **145**(1-3) (1995), 273-277.
- [28] S. GRAVIER AND M. MOLLARD, *On domination numbers of Cartesian product of paths*, *Discrete Appl. Math.*, **80**(2-3) (1997), 247-250.
- [29] F.F.M. GHALEB AND R.S. SHAHEEN, *Algorithms for finding a dominating set and the domination number of toroidal grid graphs*, *Int. J. Appl. Math.*, **8**(3) (2002), 341-350.
- [30] M. GIONFRIDDO, F. MILAZZO AND V. VACIRCA, *On the chromatic number of multipermutation graphs*, *Ars Combin.*, **25**(C) (1988), 267-274.

-
- [31] M. GIONFRIDDO, F. MILAZZO AND V. VACIRCA, *Transitive multipermutation graphs: case $4 \leq n \leq m$* , Discrete Math., **97**(1-3) (1991), 191-198.
- [32] D.R. GUICHARD, *A lower bound for the domination number of complete grid graphs*, J. Combin. Math. Combin. Comput., **49** (2004), 215-220.
- [33] E.O. HARE, S.T. HEDETNIEMI AND W.R. HARE, *Algorithms for computing the domination number of $k \times n$ complete grid graphs*, Congr. Numer., **55** (1986), 81-92.
- [34] E.O. HARE AND W.R. HARE, *Domination in graphs similar to grid graphs*, Congr. Numer., **97** (1993), 143-154.
- [35] B.L. HARTNELL, *On determining the 2-packing and domination numbers of the Cartesian product of certain graphs*, Ars Combin., **55** (2000), 25-31.
- [36] B.L. HARTNELL AND D.F. RALL, *On Vizing's conjecture*, Congr. Numer., **82** (1991), 87-96.
- [37] B.L. HARTNELL AND D.F. RALL, *Vizing's conjecture and the one-half argument*, Discuss. Math. Graph Theory, **15**(2) (1995), 205-216.
- [38] B.L. HARTNELL AND D.F. RALL, *Domination in Cartesian products: Vizing's conjecture*, Domination in graphs: Advanced topics, Marcel Dekker, New York, 1998, 163-189.
- [39] B.L. HARTNELL AND D.F. RALL, *Lower bounds for dominating Cartesian products*, J. Combin. Math. Combin. Comput., **31** (1999), 219-226.
- [40] B.L. HARTNELL AND D.F. RALL, *Improving some bounds for dominating Cartesian products*, Discuss. Math. Graph Theory, **23**(2) (2003), 261-272.
- [41] B.L. HARTNELL AND D.F. RALL, *On dominating the Cartesian product of a graph and K_2* , Discuss. Math. Graph Theory, **24**(3) (2004), 389-402.

-
- [42] T.W. HAYNES, S.T. HEDETNIEMI AND P.J. SLATER, *Fundamentals of Domination in Graphs*, Marcel Dekker, New York, 1998.
- [43] S. HEDETNIEMI, *On classes of graphs defined by special cutsets of lines*, The Many Facets of Graph Theory. Lecture Notes in Mathematics 110, pp. 171-190, 1969.
- [44] A.M. HOBBS, H. LAI, H. LAI AND G. WENG, *Uniformly dense generalized prisms over graphs*, Congr. Numer., **91** (1992), 99-105.
- [45] W. IMRICH AND H. IZBICKI, *Associative products of graphs*, Monatsh. Math., **80**(4) (1975), 277-281.
- [46] M.S. JACOBSON AND L.F. KINCH, *On the domination of the products of graphs I*, Ars Combin., **18** (1984), 33-44.
- [47] M.S. JACOBSON AND L.F. KINCH, *On the domination of the products of graphs II: Trees*, J. Graph Theory, **10**(1) (1986), 97-106.
- [48] L.Y. KANG, E.F. SHAN AND L. SUN, *Some results on domination numbers of products of graphs*, Appl. Math. J. Chinese Univ. Ser. B, **13**(1) (1998), 103-108.
- [49] W. Kocay and D. L. Kreher, *Graphs, Algorithms, and Optimization*, Chapman & Hall/CRC, Boca Raton, Florida, 2005.
- [50] S. KLAVŽAR AND N. SEIFTER, *Dominating Cartesian products of cycles*, Discrete Appl. Math., **59**(2) (1995), 129-136.
- [51] S. KLAVŽAR AND J. ŽEROVNIK, *Algebraic approach to fasciagraphs and rotagraphs*, Discrete Appl. Math., **68**(1-2) (1996), 93-100.
- [52] S. KLAVŽAR AND B. ZMAZEK, *On a Vizing-like conjecture for direct product graphs*, Discrete Math., **156**(1-3) (1996), 243-246.

-
- [53] J.H. KWAK AND J. LEE, *Isomorphism classes of graph bundles*, *Canad. J. Math.*, **42**(4) (1990), 747-761.
- [54] J. LEE AND M.Y. SOHN, *On permutation graphs over a graph*, *Commun. Korean Math. Soc.*, **10**(4) (1995), 831-837.
- [55] M. LIVINGSTON AND Q.F. STOUT, *Constant time computation of minimum dominating sets*, *Congr. Numer.*, **105** (1994), 116-128.
- [56] A. MEIR AND J.W. MOON, *Relations between packing and covering numbers of a tree*, *Pacific J. Math*, **61**(1) (1975), 225-233.
- [57] M.A. MILLER AND C.D. TRAIL, *Sparse domination of (t, k) -prisms*, *Bull. Inst. Combin. Appl.*, **46** (2006), 81-87.
- [58] O. MORIŠ, *Planarity Testing*, [Online], [cited 2008, May 12], Available from: www.fi.muni.cz/~hlineny/Teaching/AGTT/planarity-testing.pdf
- [59] C.M. MYNHARDT AND Z. XU, *Domination in prisms of graphs: Universal fixers*, *Utilitas Math.*, **78** (2009), 185-201.
- [60] L. NEBESKÝ, *Planar permutation graphs of paths*, *Comment. Math. Univ. Carolinae*, **13** (1972), 253-256.
- [61] R.J. NOWAKOWSKI AND D.F. RALL, *Associative graph products and their independence, domination and coloring numbers*, *Discuss. Math. Graph Theory*, **16**(1) (1996), 53-79.
- [62] C. PAYAN AND N.H. XUONG, *Domination-balanced graphs*, *J. Graph Theory*, **6**(1) (1982), 23-32.
- [63] T. PISANSKI, J. SHAWE-TAYLOR AND J. VRABEC, *Edge-colorability of graph bundles*, *J. Combin. Theory Ser. B*, **35**(1) (1983), 12-19.

-
- [64] F. RUBIN, *An Improved Algorithm for Testing the Planarity of a Graph*, IEEE Trans. Computers, **C-24** (1975), 113-121.
- [65] R.S. SHAHEEN, *On the domination number of $m \times n$ toroidal grid graphs*, Congr. Numer., **146** (2000), 187-200.
- [66] H.G. SINGH AND R.P. PARGAS, *A parallel implementation for the domination number of a grid graph*, Congr. Numer., **59** (1987), 297-311.
- [67] S. STUECKLE, *On natural isomorphisms of cycle permutations graphs*, Graphs Combin., **4**(1) (1988), 75-85.
- [68] L. SUN, *A result on Vizing's conjecture*, Discrete Math., **275**(1-3) (2004), 363-366.
- [69] J. HOPCROFT AND R. TARJAN, *Efficient planarity testing*, J. Assoc. Comput. Mach., **21** (1974), 549-568.
- [70] V.G. VIZING, *The Cartesian product of graphs*, Vychisl. Sistemy, **9** (1963), 30-43.
- [71] V.G. VIZING, *Some unsolved problems in graph theory*, Uspehi Mat. Nauk, **23** (1968), no. 6 (144), 117-134.
- [72] J. ŽEROVNIK, *Deriving formulas for domination numbers of fasciagraphs and rotagraphs*, Fundamentals of computation theory (Iași, 1999), 559-568, Lecture Notes in Comput. Sci., 1684, Springer, Berlin, 1999.
- [73] B. ZMAZEK AND J. ŽEROVNIK, *On domination numbers of graph bundles*, J. Appl. Math. Comput., **22**(1) (2006), 39-48.