

SOME COMPLEXES OF Pt(II) AND Pd(II) WITH SULFUR LIGANDS

by

REIKO ONO

B.Sc., University of Sussex, 1979

A THESIS SUBMITTED IN PARTIAL FULFILLMENT
OF THE REQUIREMENTS FOR THE DEGREE OF

MASTER OF SCIENCE

in the Department

of

Chemistry

ACCEPTED

FACULTY OF SCIENCE STUDIES

DATE

June 83

We accept this thesis as conforming
to the required standard

G. W. Bushnell

K. R. Dixon

R. M. Clements

T. M. Eyles

R. W. Olafson

© REIKO ONO, 1983

UNIVERSITY OF VICTORIA

February 1983

*All rights reserved. This thesis may not be reproduced
in whole or in part, by mimeograph or other means,
without the permission of the author.*

Supervisors: Professor G. W. Bushnell and Professor K. R. Dixon

ABSTRACT

A monophenylthio-bridged complex $\text{cis-}[\text{Pt}_2\text{Cl}_2(\mu\text{-Cl})(\mu\text{-SPh})(\text{PEt}_3)_2]$ has been prepared. A three dimensional X-ray structure analysis of the complex showed that it had cis geometry. The dihedral angle between the two square planes is 157.1° . The unit cell is orthorhombic, space group Pbca. The cell dimensions are: $a = 23.389(5) \text{ \AA}$, $b = 28.351(7) \text{ \AA}$, $c = 8.154(2) \text{ \AA}$, $V_{\text{cell}} = 5407(2) \text{ \AA}^3$ at $23 \pm 2^\circ\text{C}$. Positional parameters and anisotropic temperature factors of the non-hydrogen atoms of the molecule were refined by the least-squares method.

Reaction of Me_3SiSPh with $[\text{Pd}_2(\mu\text{-Cl})_2(\text{PPh}_3)_4](\text{BF}_4)_2$ yielded $[\text{Pd}_2(\mu\text{-Cl})(\mu\text{-SPh})(\text{PPh}_3)_4](\text{BF}_4)_2$ which was characterized by $^{31}\text{P}\{^1\text{H}\}$ NMR techniques. Reactions of Me_3SiSPh with $[\text{M}_2(\mu\text{-Cl})_2(\text{PEt}_3)_4](\text{BF}_4)_2$ ($\text{M} = \text{Pd}$ or Pt) under the same reaction conditions yielded a 1:1 mixture of $[\text{M}_2(\mu\text{-SPh})_2(\text{PEt}_3)_4](\text{BF}_4)_2$ and $[\text{MCl}_2(\text{PEt}_3)_2]$.

The structure of a trinuclear complex $[\text{Pt}_3\text{S}_3(\text{PMe}_2\text{Ph})_6](\text{BF}_4)_2$ has been studied using NMR and X-ray diffraction techniques. The $^{31}\text{P}\{^1\text{H}\}$ and $^{195}\text{Pt}\{^1\text{H}\}$ NMR spectra are reported. The $^2\text{J}(\text{Pt-Pt})$ coupling constant falls within the range 452-484 Hz. The $^1\text{J}(\text{Pt-P})$ coupling constant is 3201 Hz, which is similar to the value obtained for complexes of the type $[\text{Pt}_2\text{Cl}_2(\mu\text{-SPh})_2\text{L}_2]$, where L is PMe_3 , PMe_2Ph ,

PEt_3 or $\text{P}^{\text{n}}\text{Pr}_3$. The asymmetric unit of the crystal is one half of the molecular formula. The unit cell is monoclinic, space group $C2/c$. The cell dimensions at $23 \pm 2^\circ\text{C}$ are : $a = 15.447(2) \text{ \AA}$, $b = 18.033(3) \text{ \AA}$, $c = 26.505(5) \text{ \AA}$, $\beta = 96.73(2)^\circ$ and $V_{\text{cell}} = 7332(2) \text{ \AA}^3$. Full-matrix least squares refinement converged at $R = 0.0545$.

G. W. Bushnell

~~R. R. Dixon~~

R. W. Olafson

T. M. Fyles



R. M. Clements

TABLE OF CONTENTS

<u>Chapter</u>		<u>Page</u>
	Abstract	ii
	Table of contents	iv
	List of tables	vi
	List of figures	vii
	Acknowledgement	viii
I	INTRODUCTION	1
II	SYNTHESES AND CHARACTERISATIONS	5
	II-A. Syntheses	5
	II-A-1. The Mercaptide Bridged Dinuclear Complexes of Pt(II) and Pd(II)	5
	II-A-2. The Sulfide Bridged Trinuclear Complex, $[M_3S_2L_6]X_2$	10
	II-A-3. Polysulfide Complexes of Pt(II) Containing a PtS_4 Ring	11
	II-B. NMR Results and Discussion	13
	II-B-1. ^{31}P NMR Spectra of Mercaptide Bridged Dinuclear Complexes of Pt(II) and Pd(II)	15
	II-B-2. ^{31}P and ^{195}Pt NMR Spectra of $[Pt_3S_2(PMe_2Ph)_6](BET_4)_2$	24
	EXPERIMENTAL	34
III	X-RAY DIFFRACTION STUDIES	42
	III-A. Descriptions and Discussion of the Structures	42
	III-A-1. Structure of $[Pt_2Cl_3(SPh)(PEt_3)_2]$...	42

<u>Chapter</u>	<u>Page</u>
III-A-2. Structure of $[\text{Pt}_3\text{S}_2(\text{PMe}_2\text{Ph})_6](\text{BEt}_4)_2$	51
III-B. X-Ray Experimental	62
III-B-1. X-Ray Experimental of $[\text{Pt}_2\text{Cl}_3(\text{SPh})(\text{PEt}_3)_2]$	67
III-B-2. X-Ray Experimental of $[\text{Pt}_3\text{S}_2(\text{PMe}_2\text{Ph})_6](\text{BEt}_4)_2$	72
III-B-3. X-Ray Experimental of $[(\text{dppe})\text{PtS}_4]$	78
EPILOGUE	79
REFERENCES	81
APPENDIX I	85
APPENDIX II	95

LIST OF TABLES

<u>Figure</u>		<u>Page</u>
1	^{31}P NMR parameters for dinuclear complexes containing PhS-bridges	23
2	^{31}P NMR parameters for chloro-bridged dimers used as reactants	23
3	Mercaptide bridged complexes of Pt(II) and Pd(II)	41
4	Interatomic distances for $\text{cis-}[\text{Pt}_2\text{Cl}_3(\text{SPh})(\text{PET}_3)_2]$	48
5	Bond angles for $\text{cis-}[\text{Pt}_2\text{Cl}_3(\text{SPh})(\text{PET}_3)_2]$	49
6	Mean planes for $\text{cis-}[\text{Pt}_2\text{Cl}_3(\text{SPh})(\text{PET}_3)_2]$	50
7	Interatomic distances for $[\text{Pt}_3\text{S}_2(\text{PMe}_2\text{Ph})_6](\text{BEt}_4)_2$	59
8	Bond angles for $[\text{Pt}_3\text{S}_2(\text{PMe}_2\text{Ph})_6](\text{BEt}_4)_2$	60
9	Mean planes for $[\text{Pt}_3\text{S}_2(\text{PMe}_2\text{Ph})_6](\text{BEt}_4)_2$	61
10	Fractional atomic coordinates and temperature parameters for $[\text{Pt}_2\text{Cl}_3(\text{SPh})(\text{PET}_3)_2]$	68
11	Anisotropic temperature parameters for $[\text{Pt}_2\text{Cl}_3(\text{SPh})(\text{PET}_3)_2]$	70
12	Selected intermolecular distances for $[\text{Pt}_2\text{Cl}_3(\text{SPh})(\text{PET}_3)_2]$	71
13	Fractional atomic coordinates and temperature parameters for $[\text{Pt}_3\text{S}_2(\text{PMe}_2\text{Ph})_6](\text{BEt}_4)_2$	73
14	Anisotropic temperature parameters for $[\text{Pt}_3\text{S}_2(\text{PMe}_2\text{Ph})_6](\text{BEt}_4)_2$	75
15	Selected intermolecular distance for $[\text{Pt}_3\text{S}_2(\text{PMe}_2\text{Ph})_6](\text{BEt}_4)_2$	77

LIST OF FIGURES

<u>Figure</u>		<u>Page</u>
1	Iron-sulfur centers found in rubredoxin and ferredoxin	1
2	A Mo-Fe-S cluster in a FeMo cofactor model of nitrogenase	2
3	Isotopomers and their natural abundances of dinuclear Pt(II) complexes	15
4	^{31}P NMR spectrum of $[\text{Pt}_2\text{Cl}_3(\text{SPh})(\text{PEt}_3)_2]$	19
5	^{31}P NMR spectrum of $[\text{Pt}_2\text{Cl}_2(\text{SPh})_2(\text{PEt}_3)_2]$	20
6	^{31}P NMR spectrum of $[\text{Pt}_2(\text{SPh})_2(\text{PEt}_3)_4](\text{BF}_4)_2$	21
7	^{31}P NMR spectrum of $[\text{Pd}_2\text{Cl}(\text{SPh})(\text{PPh}_3)_4](\text{BF}_4)_2$	22
8	Isotopomers and their natural abundances of $[\text{Pt}_3\text{S}_2\text{L}_6]^{2+}$	24
9	^{31}P NMR spectrum of $[\text{Pt}_3\text{S}_2(\text{PMe}_2\text{Ph})_6](\text{BET}_4)_2$	30
10	The simulated ^{31}P NMR spectra for V and VI ...	31
11	^{195}Pt NMR spectrum of $[\text{Pt}_3\text{S}_2(\text{PMe}_2\text{Ph})_6](\text{BET}_4)_2$	32
12	The simulated ^{195}Pt NMR spectra for V and VI ..	33
13	Molecular structure of $\text{cis}-[\text{Pt}_2\text{Cl}_3(\text{SPh})(\text{PEt}_3)_2]$	46
14	Schematic molecular structure diagram of $\text{cis}-[\text{Pt}_2\text{Cl}_3(\text{SPh})(\text{PEt}_3)_2]$	47
15	Molecular structure of $[\text{Pt}_3\text{S}_2(\text{PMe}_2\text{Ph})_6]^{2+}$	56
16a	Schematic molecular structure diagram of $[\text{Pt}_3\text{S}_2(\text{PMe}_2\text{Ph})_6]^{2+}$	57
16b	Schematic molecular structure diagram of BET_4^{2-}	58

ACKNOWLEDGEMENT

I wish to express my appreciation to my supervisors Dr. Gordon W. Bushnell and Dr. Keith R. Dixon for their encouragement and guidance throughout my research. I would like to thank Dr. Alan Pidcock of the University of Sussex, who was at the University of Victoria on a sabbatical year, for helpful guidance and suggestions. Thanks are also extended to Kathy Beveridge for technical assistance and to Christine Greenwood for her excellent NMR spectra.

CHAPTER I

INTRODUCTION

Sulfur is known to form stable chemical bonds with almost all the transition metals. Despite this fact, transition metal-sulfur complex chemistry has not, until very recently, been an active field of research. The ligands concerned in this work have sulfur as a donor atom. These have not been investigated as extensively as the ligands whose donor atoms are carbon, nitrogen, oxygen or phosphorus. With the growing interest in biological and industrial sulfur containing catalysts, it is rapidly becoming popular to study transition metal complexes containing metal-sulfur bonds.

Complexes containing RS^- and S^{2-} ligands are known to exist in biological systems. Rubredoxins and ferredoxins contain redox centers composed of sulfur and iron atoms, whose structures are shown in Figure 1. The two-iron and four-iron clusters contain two-fold and three-fold bridging sulfide ligands, respectively. The $MoFe_3S_4$ cluster

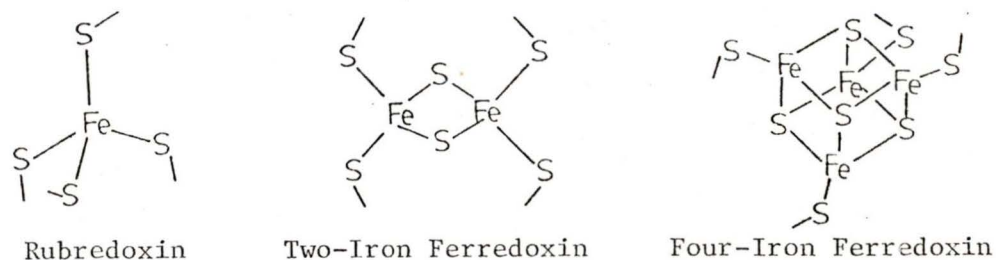

Figure 1. Iron-sulfur centers found in rubredoxin and ferredoxin

of FeMo cofactor is believed to be the active site of nitrogenases. It is a cubane type cluster similar to the four-iron ferredoxin redox centers. Many FeMo cofactor model systems such as the example shown in Figure 2 have been intensively studied.^{1,2,3}

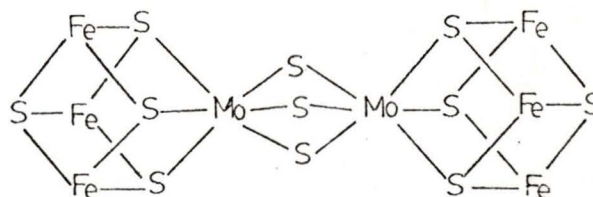
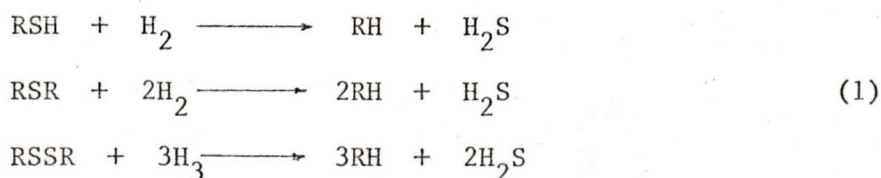

Figure 2. A Mo-Fe-S cluster in a FeMo cofactor model of nitrogenase

Hydrodesulfurization is an important reaction in the purification of petroleum products. It involves the hydrogenolysis of organosulfur compounds in which hydrocarbons and hydrogen sulfide are formed(1).



A commonly used hydrogenolysis catalyst is sulfided molybdenum and cobalt supported on alumina.^{4,5} In the most accepted catalytic reaction mechanism, the organosulfur compound is coordinated to the vacant site on the molybdenum ion. The sulfide ligands on the catalyst surface

react with molecular hydrogen to form hydrosulfido ligands. The hydrogenolysis reaction then occurs between these adsorbed species.⁶ To verify the above reaction mechanism and to synthesize homogeneous catalysts, the reactivity of molecular hydrogen and coordinated sulfide ligands needs to be studied. The first example of such a reaction to form hydrosulfido ligands from molecular hydrogen and coordinated sulfide ligands has been reported recently. Methyl-substituted cyclopentadienylmolybdenum complexes of the type $[(CH_3)_n(C_5H_{5-n})MoS_2]_2$ reacted with hydrogen and gave a dimeric complex with hydrosulfido ligands, of the type $[(CH_3)(C_5H_{5-n})Mo(S)SH]_2$.⁷

Transition metal ions Pt(II) and Pd(II) are class B or soft metals⁸ and form stable complexes with higher atomic number elements. They strongly bond with sulfur which is large and polarizable.⁹ The relatively great polarizability of sulfur causes the coordinating abilities of sulfur ligands to depend on their permanent dipole moments.¹⁰ There is another property of sulfur which explains the stability of metal-sulfur bonds. Sulfur has low-energy d-orbitals which allow it to accept some π -electrons from the metal. This π -back donation contributes to the further strengthening of the bond.

A number of Pt(II) and Pd(II) complexes containing sulfur donor ligands have been reported up to the present time.^{11,12} This thesis includes the structure elucidation of mercaptide bridged, sulfide bridged and tetrasulfide complexes. In all the complexes investigated,

the bond angles about sulfur are approximately tetrahedral, which suggests that the sulfur can be roughly described as sp^3 . Mercaptide(μ), three-fold bridging sulfide and polysulfide ligands have one, one and two lone pairs per sulfur, respectively. All the M-S-M bond angles lie between 80° and 96° , which is smaller than the tetrahedral angle, allowing the lone pair to occupy a larger space. This is attributed to the large steric effect of a lone pair and to the incomplete involvement of the s-orbital in the hybridization. The trans influence of sulfur ligands can be determined from the analysis of the bond length of a given metal-ligand bond. The cis and trans influence of sulfur ligands is reflected also in NMR data. Of the two major NMR parameters: chemical shifts and coupling constants, the latter has been widely used in bonding studies. Coupling constants give direct information about metal-ligand σ bonding, but only the possibility of indirect information on the π -back bonding. Insufficient data are available for us to reach any conclusion about metal-sulfur bonds at this stage. However, this thesis presents some useful information on the subject.

CHAPTER II

SYNTHESES AND CHARACTERISATIONS

II-A. Syntheses

II-A-1. The Mercaptide Bridged Dinuclear Complexes of Pt(II) and Pd(II)

Ethylthio-bridged complexes of the type $[M_2Cl_2(\mu-Cl)_n(\mu-SEt)_{2-n}L_2]$ ($M=Pd^{13}$ or Pt^{14} , $n=0,1$ and L =tertiary phosphine) have been obtained in the past by treatment of neutral dimers of the type $[M_2Cl_2(\mu-Cl)_2L_2]$ with ethanethiol. The corresponding phenylthio-bridged Pt(II) complexes have been prepared from the reaction of neutral dimer with thiophenol¹⁵, $NaSPh^{15}$, $LiSPh^{16}$ or Me_3SiSPh^{17} . The use of Me_3SiSPh seems to be the most convenient route for the chloride bridge substitution with SPh^- and gives the highest yield. We have prepared $[Pt_2Cl_2(\mu-Cl)(\mu-SPh)L_2]$ and $[Pt_2Cl_2(\mu-SPh)_2L_2]$ ($L=P^nBu_3$ or PEt_3) by the reaction of trans- $[Pt_2Cl_2(\mu-Cl)_2L_2]$ and Me_3SiSPh . Some attempts to substitute the chloride bridge of monophenylthio-bridged complexes with a diphenyl phosphido group were made so as to investigate the correlation of the NMR parameters with the Pt-P-Pt bond angles. The $^{31}P\{^1H\}$ NMR analyses of the mercaptide bridged complexes are described in Chapter II-B and the X-ray structure analysis of *cis*- $[Pt_2Cl_2(\mu-Cl)(\mu-SPh)(PEt_3)_2]$ in Chapter III-A-1. The reactivities of Me_3SiSPh towards cationic complexes of the type $[M_2(\mu-Cl)_2L_4](BF_4)_2]$ ($M=Pd$ or Pt , $L=PEt_3$ or PPh_3) were also studied. The monophenylthio-bridged cationic complex $[Pd_2(\mu-Cl)(\mu-SPh)L_4](BF_4)_2$

was isolated and analyzed.

Results and Discussion

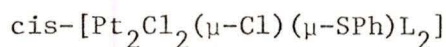

The monophenylthio-bridged complex $\text{cis-}[\text{Pt}_2\text{Cl}_2(\mu\text{-Cl})(\mu\text{-SPh})\text{L}_2]$ was formed readily by the reaction of $\text{trans-}[\text{Pt}_2\text{Cl}_2(\mu\text{-Cl})_2\text{L}_2]$ and an equivalent molar quantity of Me_3SiSPh in dichloromethane at room temperature. When L was P^nBu_3 , 2.3 molar equivalents of Me_3SiSPh were required to form the corresponding monophenylthio-bridged complex. The complex is stable both in solution and in the solid state. The $^{31}\text{P}\{^1\text{H}\}$ NMR spectrum is shown in Figure 4 and the NMR parameters are listed in Table 1. The $^{31}\text{P}\{^1\text{H}\}$ NMR analysis agreed with the X-ray structural studies and the complex was found to exist exclusively as the cis isomer.

It was suggested that there should be some correlations between the Pt-P-Pt bond angles of diphenylphosphido-bridged complexes and the $^{31}\text{P}\{^1\text{H}\}$ NMR parameters.¹⁸ It was of interest to us to prepare a series of complexes of the type $[\text{Pt}_2\text{Cl}_2(\mu\text{-X})(\mu\text{-PPh}_2)\text{L}_2]$ (2) where X is any bridging ligand other than -PPh_2 . We chose -SPh for -X since mercaptide

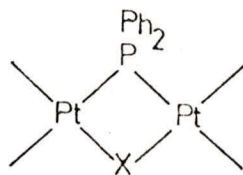

(2)

bridges were expected to be significantly more stable than chloride

bridges¹⁹ and to allow the substitution of the chloride bridge in $\text{cis-}[\text{Pt}_2\text{Cl}_2(\mu\text{-Cl})(\mu\text{-SPh})(\text{PET}_3)_2]$ with PPh_2^- .

We have made several attempts to substitute the chloride bridge of $\text{cis-}[\text{Pt}_2\text{Cl}_2(\mu\text{-Cl})(\mu\text{-SPh})(\text{PET}_3)_2]$ with PPh_2^- . The complex was allowed to react with: equivalent amounts of PPh_2H , PPh_2H in the presence of p-toluidine, a mixture of NaOEt and PPh_2H or $\text{Me}_3\text{SiPPh}_2$, in dichloromethane all at low temperatures. All the reactions gave mixtures of many complexes. One of the main products was $\text{cis-}[\text{Pt}(\text{PET}_3)(\text{PPh}_2\text{H})\text{Cl}_2]$, suggesting that there was a Pt-S bond cleavage. It is known that halogen bridged complexes of Pt(II) are readily cleaved by tertiary phosphine whereas the corresponding thio-bridged complexes are stable to such reactions.¹¹ However, the above observations indicate that the monothio-bridged complexes seem to have much more unstable Pt-S bonds than do dithio-bridged complexes. It seemed to us that $\text{Me}_3\text{SiPPh}_2$ was the best reagent for introducing a diphenylphosphido-bridge, but there were technical difficulties using this reagent. It is very moisture sensitive and forms PPh_2H on reaction with a trace amount of water. It was technically impossible to carry out the reaction of the monophenylthio-bridged complex without the presence of any PPh_2H impurity.

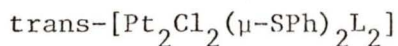

The neutral dimer $[\text{Pt}_2\text{Cl}_4\text{L}_2]$ reacts with 2.7 molar equivalents of Me_3SiSPh at room temperature to give $\text{trans-}[\text{Pt}_2\text{Cl}_2(\mu\text{-SPh})_2\text{L}_2]$. No cis isomer was detected by $^{31}\text{P}\{^1\text{H}\}$ NMR. The same product was obtained from

the reaction of the monophenylthio-bridged complex with one molar equivalent of Me_3SiSPh (3).

Reactions of Me_3SiSPh with $[\text{M}_2(\mu\text{-Cl})_2\text{L}_4](\text{BF}_4)_2$

The reaction of Me_3SiSPh with cationic complexes of the type $[\text{M}_2(\mu\text{-Cl})_2\text{L}_4](\text{BF}_4)_2$ ($\text{M}=\text{Pd}$ or Pt , $\text{L}=\text{PPh}_3$ or PEt_3) was examined under the same conditions as the preparation of $\text{cis-}[\text{Pt}_2\text{Cl}_2(\mu\text{-Cl})(\mu\text{-SPh})\text{L}_2]$. A monophenylthio-bridged complex was obtained when $\text{M}=\text{Pd}$ and $\text{L}=\text{PPh}_3$ (5). When $\text{L}=\text{PEt}_3$, a one to one mixture of diphenylthio-bridged complex $[\text{M}_2(\mu\text{-SPh})_2\text{L}_4](\text{BF}_4)_2$ and monomeric complex $[\text{MCl}_2\text{L}_2]$ was obtained (4).

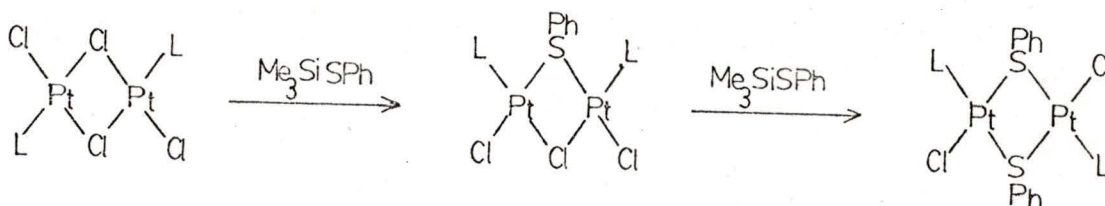

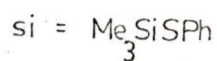
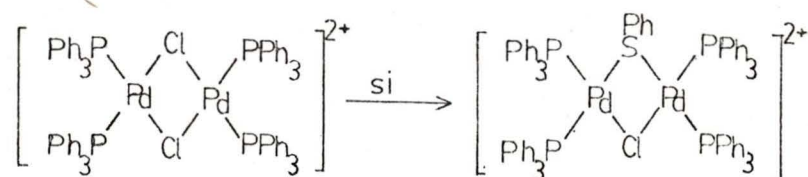
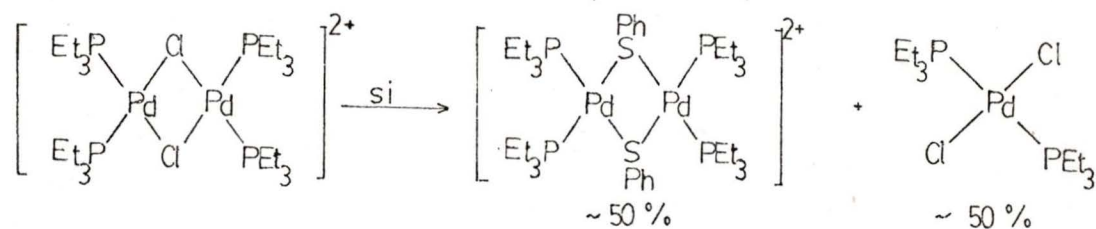
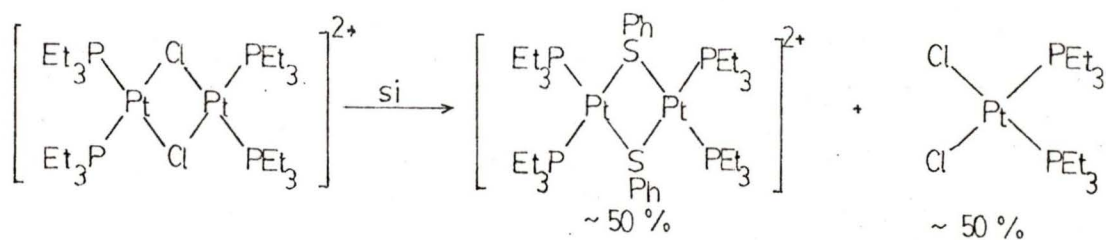

(4)

(5)

II-A-2. The Sulfide-Bridged Trinuclear Complex, $[M_3S_2L_6]X_2$

The complexes $[Pt_3S_2(PMe_2Ph)_6]X_2$, where $X=ClO_4^-$, BF_4^- or BPh_4^- had been synthesized by Chatt and Mingos¹⁹ from the reaction of $cis-[PtCl_2(PMe_2Ph)_2]$ with sodium sulfide in ethanol, and later treatment with $HClO_4$, $NaBF_4$ or $NaBPh_4$, respectively. The yield was very low, about 12%, and the structure was not fully characterized prior to this work. We carried out a reaction of $cis-[PtCl_2(PMe_2Ph)_2]$ with lithium sulfide in the presence of excess BEt_3 and obtained a high yield (85%) of the trinuclear complex $[Pt_3S_2(PMe_2Ph)_6](BEt_4)_2$.

Analogous complexes of nickel and palladium were reported in recent papers.^{20,21} Complex $[Pd_3S_2(PMe_3)_6](BPh_4)_2$ was isolated accidentally when a solution of $[Pd(PMe_3)_3H](BPh_4)_2$ in acetone was stirred in an atmosphere of carbonyl sulfide, COS .²⁰ The same complex was also obtained from the reaction of H_2S and $[Pd(MeCN)_4](BF_4)_2$ in acetonitrile in the presence of PMe_3 , followed by anion replacement by $NaBPh_4$. The nickel analogue $[Ni_3S_2(PEt_3)_6](BPh_4)_2$ was isolated two years before the palladium compound during the investigation of H_2S reactivity towards transition metals. The nickel complex was formed by bubbling H_2S through an ethanol solution of $Ni(BF_4)_2 \cdot 6H_2O$ in the presence of PEt_3 .²¹

The stability of trinuclear complexes of the type $[M_3S_2L_6]X_2$ ($M=Pt$, Pd or Ni ; L =tertiary phosphine; X =bulky anion) is due mainly to the favourable geometry of M_3S_2 units. The molecular structure of the complex $[Pt_3S_2(PMe_2Ph)_6](BEt_4)_2$, along with data for structurally related complexes is described and discussed in Chapter III-A-2. Analysis of the ³¹P and ¹⁹⁵Pt NMR spectra are described in Chapter II-B.

II-A-3 Polysulfide Complexes of Pt(II) Containing a PtS_4 Ring

Polysulfide complexes of transition metals contain one or more heteronuclear rings consisting of one metal and two or more sulfur atoms. Metals such as Ti, V, Mo, W, Co, Rh, Ir, Ni, Pd, Pt, Cu and Ag are known to form such complexes, and a recent review by Schmidt and Hoffmann²² provides the references to the work done in this field. The only known polysulfide complexes of Pt(II) are those containing MS_4 or MS_5 rings,^{19,23} whereas polysulfide complexes containing MS_2 , MS_3 , MS_4 or MS_5 rings exist for other metals. Although much research has been done on platinum pentasulfide complexes, very little has been done on the tetrasulfide complexes.

There are only three tetrasulfide complexes of Pt(II) which have been isolated: $[(\text{PPh}_3)_2\text{PtS}_4]$,¹⁹ $[(\text{dppe})\text{PtS}_4]$ ¹⁹ and $[(\text{tol})_2\text{PtS}_4]$ ²⁶, where $\text{dppe}=\text{Ph}_2\text{PCH}_2\text{CH}_2\text{PPh}_2$ and $\text{tol}=\text{tris-}p\text{-tolylphosphine}$. The first two complexes were prepared by Chatt and Mingos by treating Pt^0 complexes $[\text{Pt}(\text{dppe})_2]$ and $[\text{Pt}(\text{PPh}_3)_4]$ with six molar equivalents of elemental sulfur.¹⁹ However, when the same reaction was repeated with $[\text{Pt}(\text{PPh}_3)_2]$ or $[\text{Pt}(\text{PPh}_3)_3]$ as starting material, a polymeric complex $[\text{Pt}(\text{PPh}_3)_2\text{S}]_n$ was obtained.²⁴ The reaction of $\text{cis-}[\text{PtCl}_2(\text{PPh}_3)_2]$ with sodium sulfide also gave the same polymeric substance.²⁴ It seems possible that the product from the reaction of $[\text{Pt}(\text{PPh}_3)_4]$ with elemental sulfur was a mixture of the tetrasulfide and polymeric complexes. This could be the cause of the discrepancies in the melting points of $[(\text{PPh}_3)_2\text{PtS}_4]$ reported by two different authors: $138\text{-}140^\circ\text{C}$.¹⁹ and $167\text{-}168^\circ\text{C}$.²⁵ (the melting point of $[\text{Pt}(\text{PPh}_3)_2\text{S}]_n$ is 246°C .²⁴). Beck et al. later reported

that tetrasulfide complexes were more conveniently made by the reaction of tris(pentasulfido)platinate or bis(pentasulfido)platinate with tertiary phosphines (6).²⁵

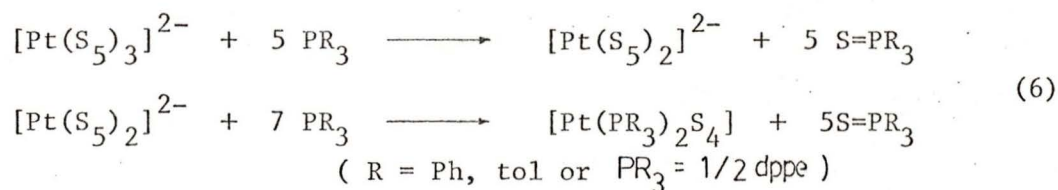

The infra red spectrum of the tetrasulfide complex $[(\text{dppe})\text{PtS}_4]$ prepared by this method was reported to be identical to that reported by Chatt and Mingos.²⁵ We followed the method by Chatt and Mingos to make this complex and attempted to determine its molecular structure by X-ray diffraction techniques (refer to Chapter III-B-3).

II-B. NMR Results and Discussion

^{31}P NMR is a powerful technique for investigating transition metal-phosphorus complexes. Most of the complexes used during this research provided sufficient structural information in their ^{31}P NMR spectra. When a molecule has more than two platinum atoms, the ^{195}Pt NMR technique becomes important. In such a molecule, the interpretation of ^{195}Pt NMR spectrum is significantly less complicated than that of the ^{31}P NMR spectrum. The analysis of the trinuclear complex $[\text{Pt}_3\text{S}_2(\text{PMe}_2\text{Ph})_6](\text{BET}_4)_2$ in Chapter II-B-2 illustrates such an example.

A characteristic feature of the NMR spectroscopy of platinum complexes arises from the presence of the magnetically active isotope ^{195}Pt ($I=\frac{1}{2}$) with natural abundance 33.8%. This complicates the spectra derived from polynuclear complexes of platinum. A polynuclear complex of platinum exists as a mixture of several magnetic isomers called isotopomers which differ in kinds and number of platinum isotopes within the molecule. The isotopomers are chemically equivalent but magnetically non-equivalent. Each isotopomer gives a spectrum characteristic of its spin system. An experimental spectrum is the sum of these spectra from isotopomers, but in practice only those with high natural abundances are observed. To analyse the spectra of polynuclear complexes, we have to consider the spin system of each naturally abundant isotopomer, then the sum of these spectra has to agree with the experimental spectrum.

The natural abundance of magnetically active ^{31}P ($I=\frac{1}{2}$) is 100%. In ^{31}P NMR spectra, the resonance of a platinum-phosphorus complex is

flanked by satellites which arise from the coupling between ^{31}P and ^{195}Pt . The ^{31}P NMR spectra of palladium-phosphorus complexes are much simpler than these, because there is no palladium isotope with $I=\frac{1}{2}$ and hence no coupling to phosphorus is observed. The fine structure arises only from phosphorus-phosphorus couplings.

The spectrum of $(\text{dppe})\text{PtS}_4$ is simple since it involves only one kind of phosphorus and one metal. It is a first order spectrum with a singlet at $\delta=-91.1\text{ppm}$ flanked by satellites with $^1J(\text{Pt-P})=2805\text{Hz}$. The NMR spectra of dinuclear and trinuclear complexes have some non-first order character. Their interpretations are described in detail in the following chapters. The analyses were simplified by making one assumption based upon abundant experimental data²⁹; namely that one-bond platinum-phosphorus coupling constants are large and positive with values about 3 to 4 KHz.

II-B-1. ^{31}P NMR Spectra of Mercaptide Bridged Dinuclear Complexes of Pt(II) and Pd(II)

The dinuclear complexes of Pt(II) have three isotopomers shown in Figure 3 along with their relative abundances. Isotopomer I contains two non-active platinum isotopes ($I=0$), isotopomer II one of each isotope ($I=0$ and $I=\frac{1}{2}$) and isotopomer III two active isotopes ($I=\frac{1}{2}$). The

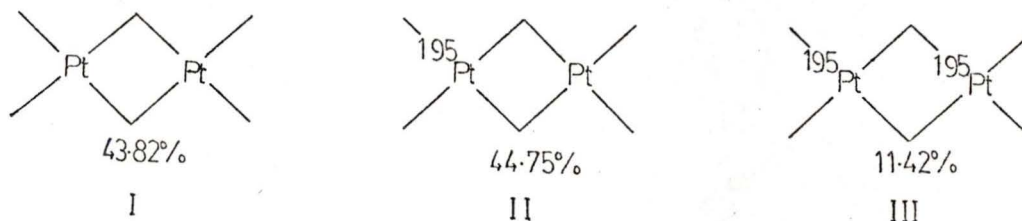

Figure 3. Isotopomers and their natural abundances of dinuclear Pt(II) complexes.

calculation of natural abundance of each isotopomer is shown below (7).

$$\begin{aligned}
 \text{I.} & \quad 0.662^2 \times 100 = 43.82 \\
 \text{II.} & \quad (0.662 \times 0.338 \times 100) \times 2 = 44.75 \\
 \text{III.} & \quad 0.338^2 \times 100 = 11.42
 \end{aligned} \tag{7}$$

These isotopomers have the same chemical shifts, but the patterns of their spectra are not identical. All the three isotopomers can be observed in the experimental spectra, yet III has much smaller natural abundance and hence smaller peaks than the other two. The spectrum from I appears only as a singlet for one kind of phosphorus, because there is no coupling between phosphorus and platinum ($I=0$). The spectrum from II is the most important of the three, as its peaks are intense and

contain platinum-phosphorus coupling information. The spin system of II and III are AA'X and AA'XX', respectively. The procedure involved in the spectral analysis is summarised in a monograph by Abraham.²⁸

Sufficient structural information was obtained for dinuclear complexes of Pt(II) by applying a first order analysis. The spectra obtained for the dinuclear complexes were sufficiently simple that further detailed analysis by computer simulation proved unnecessary. The $^{31}\text{P}\{^1\text{H}\}$ NMR parameters of the mercaptide bridged complexes relevant to this research are listed in Table 1, and those of chloride bridged complexes used as starting materials in Table 2. The spectral analysis of each mercaptide bridged complex is described in detail as follows.

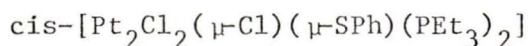

The spectrum of the title complex is shown in Figure 4. The largest peak in the center ($\delta = -130.6\text{ppm}$) is the singlet from I. The satellites arise from II whose spin system is AA'X. The larger satellites arise from one-bond platinum-phosphorus coupling, $^1\text{J}(\text{Pt-P}) = 3962\text{Hz}$, and the satellites close to the central peak from three-bond platinum-phosphorus coupling, $^3\text{J}(\text{Pt-P}) = 36\text{Hz}$. The $^1\text{J}(\text{Pt-P})$ coupling constant is much closer to $\text{trans-}[\text{Pt}_2\text{Cl}_4(\text{PEt}_3)_2]$ (3831Hz) than to $\text{trans-}[\text{Pt}_2\text{Cl}_2(\mu\text{-SPh})_2(\text{PEt}_3)_2]$ (3181Hz), indicating the phosphine of the title complex is trans to chlorine rather than to sulfur. The satellites at 3962Hz apart are significantly more intense than those at 36Hz apart. This is due to the overlapping with the spectrum from III. The spin system of III is AA'XX',

but appear only as a simple doublet with $^1J(\text{Pt-P})=3962\text{Hz}$. The coupling between two phosphorus atoms through four bonds is very small and does not appear on the spectrum. This feature is commonly observed when two phosphorus atoms are cis to each other.³⁰

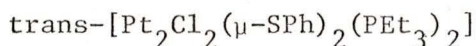

The experimental spectrum (Figure 5) contains fine structures from II and III. One-bond metal-phosphine coupling of II is measured directly from the spectrum as the separation between the two satellites furthest from the center; $^1J(\text{Pt-P})=3181\text{Hz}$. The other phosphorus of II which is three bonds away from ^{195}Pt gives resonances close to the central peak with $^3J(\text{Pt-P})=52\text{Hz}$. They are further split by remote coupling with a phosphorus, $^4J(\text{Pt-P})=11\text{Hz}$. The smallest satellites separated by about 3100Hz are due to III.

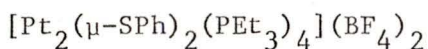

The spectral interpretation for the title complex (Figure 6) is similar to that of $\text{trans-}[\text{Pt}_2\text{Cl}_2(\mu\text{-SPh})_2(\text{PEt}_3)_2]$. In this experimental spectrum, spectra from I and II are seen clearly, but not that from III. The coupling constants measured from the resonance pattern are $^1J(\text{Pt-P})=2881\text{Hz}$, $^3J(\text{Pt-P})=19\text{Hz}$ and $^2J(\text{P-P})=7\text{Hz}$.

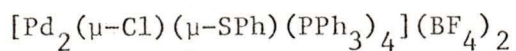

The cationic palladium complex (8) gives a non-first order spectrum (Figure 7). The four phosphorus atoms are magnetically non-equivalent and the spin system is AA'XX'. The fine structure is derived from the coupling between four magnetically non-equivalent phosphorus nuclei. The pattern of the spectrum resembles the theoretically obtained spectrum.³¹ In theory, $^2J(\text{P-P})$ and $^4J(\text{P-P})$ can be calculated from the spectrum, but there is no unique solution for these parameters.

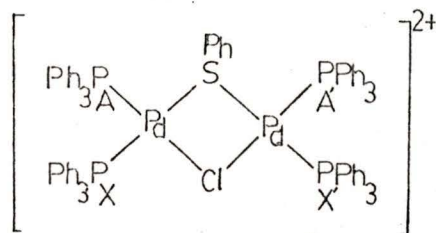

(8)

Figure 4. $^{31}\text{P}\{^1\text{H}\}$ NMR spectrum of $[\text{Pt}_2\text{Cl}_3(\text{SPh})(\text{PEt}_3)_2]$.

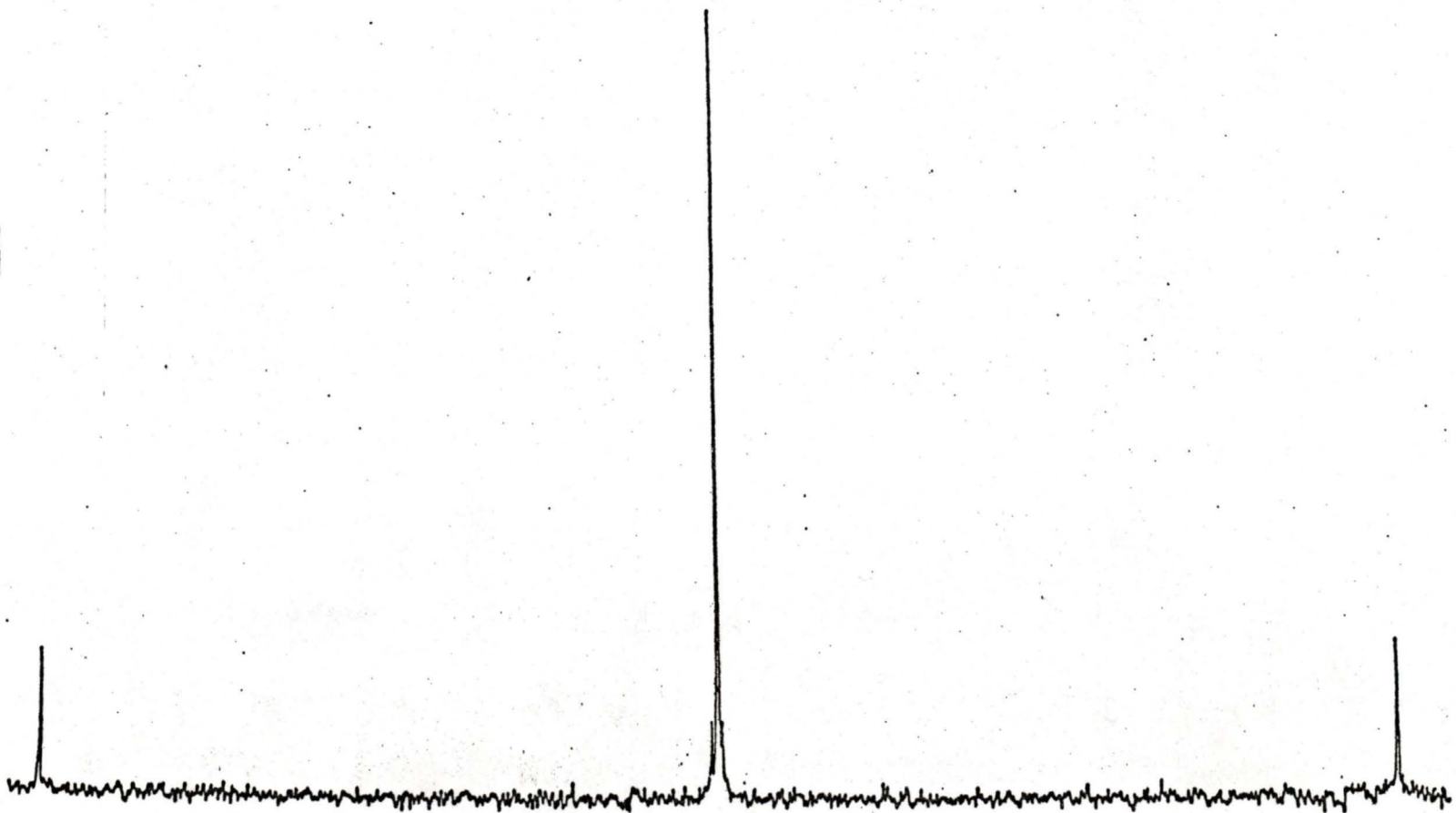

Figure 5. $^{31}\text{P}\{^1\text{H}\}$ NMR spectrum of $[\text{Pt}_2\text{Cl}_2(\text{SPh})_2(\text{PEt}_3)_2]$.

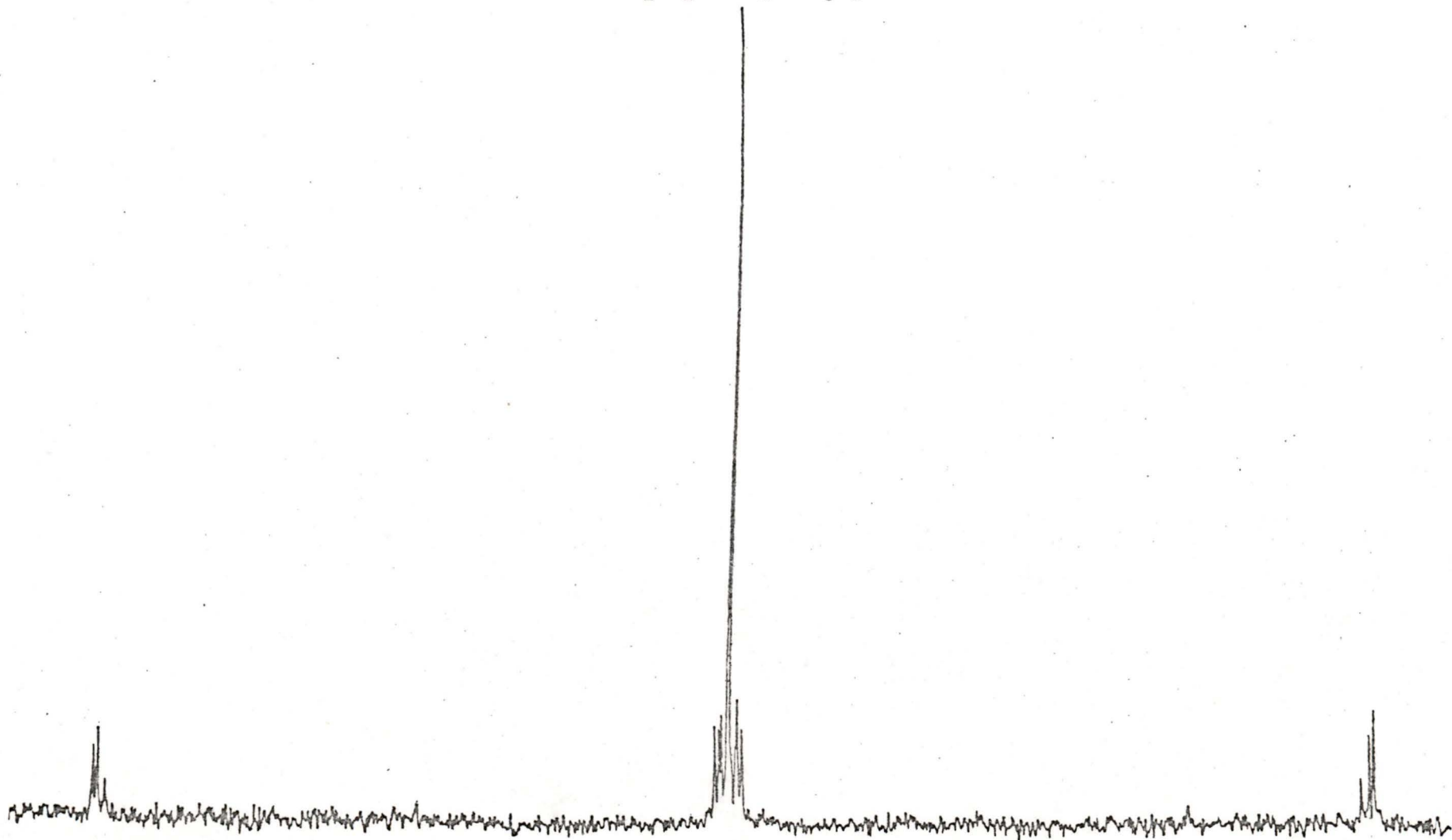

Figure 6. $^{31}\text{P}\{^1\text{H}\}$ NMR spectrum of $[\text{Pt}_2(\text{SPh})_2(\text{PEt}_3)_4](\text{BF}_4)_2$.

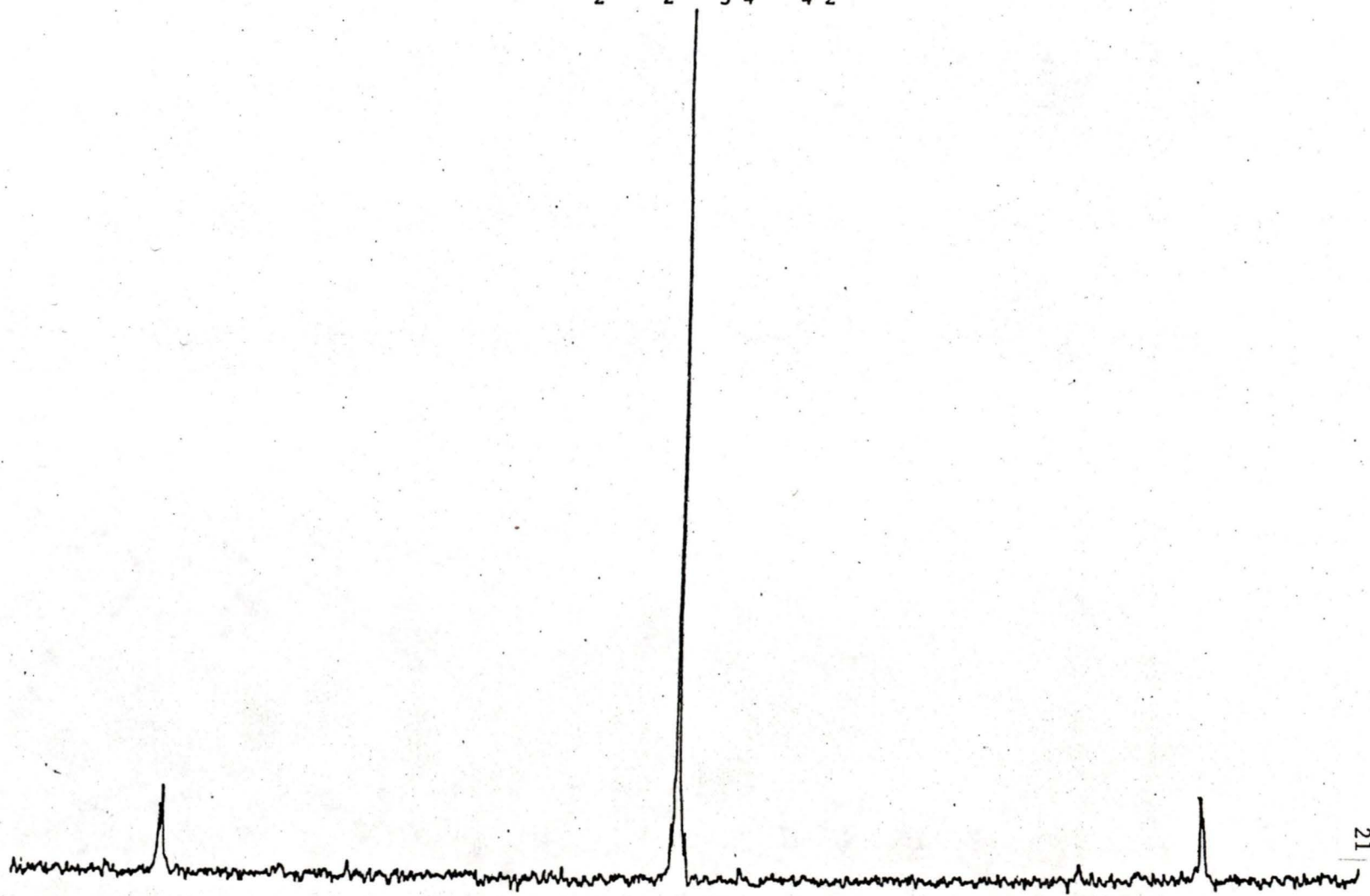

Figure 7. $^{31}\text{P}\{^1\text{H}\}$ NMR spectrum of $[\text{Pd}_2\text{Cl}(\text{SPh})(\text{PPh}_3)_4](\text{BF}_4)_2$.

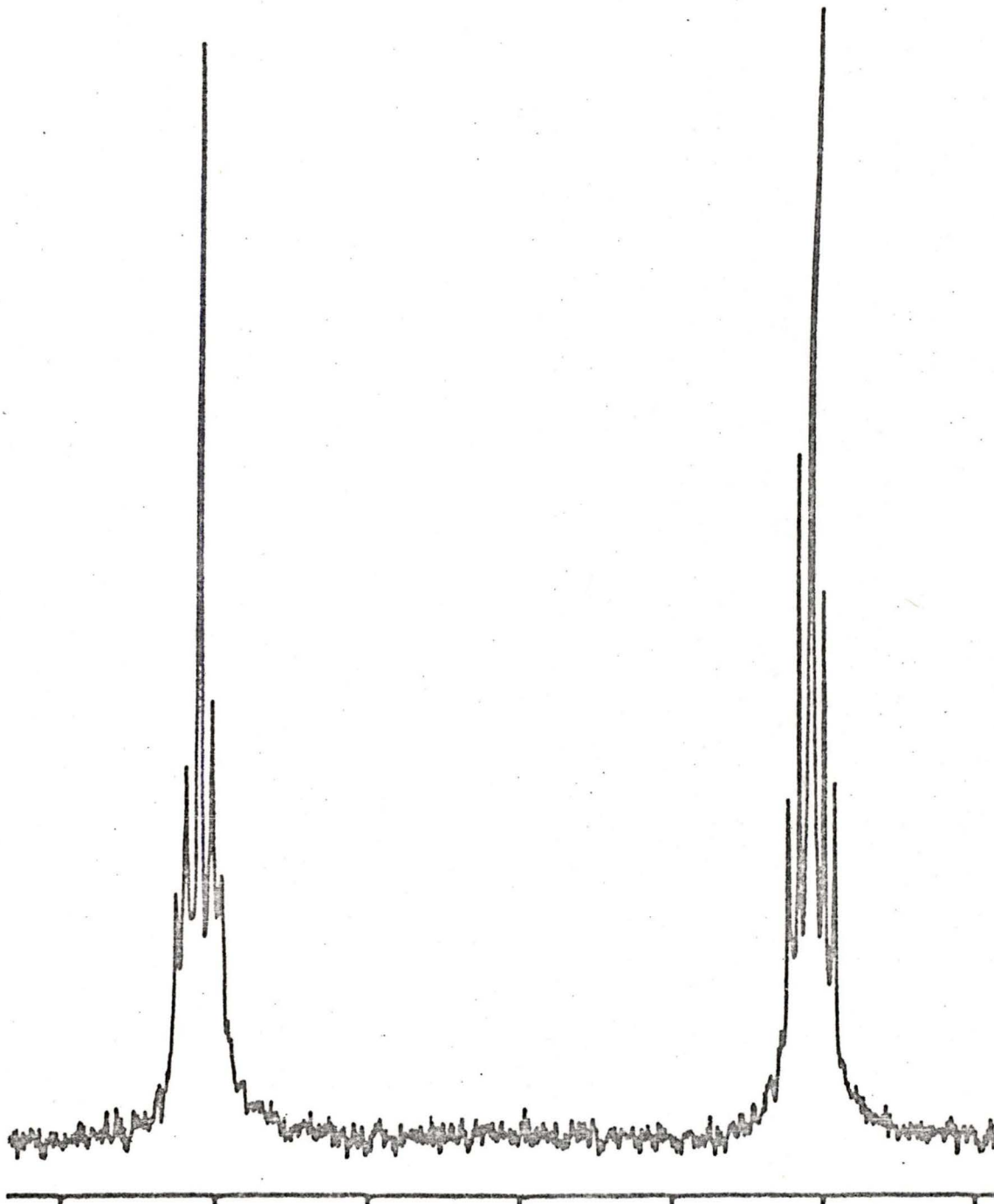

Table 1. $^{31}\text{P}\{^1\text{H}\}$ NMR Parameters for Dimers Containing PhS-Bridges

	δ (ppm)	$^1\text{J}(\text{Pt-P})$ (Hz)	
cis- $[\text{Pt}_2\text{Cl}_2(\mu\text{-Cl})(\mu\text{-SPh})(\text{PMe}_3)_2]$	-164.5	3967	*
cis- $[\text{Pt}_2\text{Cl}_2(\mu\text{-Cl})(\mu\text{-SPh})(\text{PEt}_3)_2]$	-130.6	3965	
cis- $[\text{Pt}_2\text{Cl}_2(\mu\text{-Cl})(\mu\text{-SPh})(\text{P}^n\text{Pr}_3)_2]$	-139.7	3940	*
cis- $[\text{Pt}_2\text{Cl}_2(\mu\text{-Cl})(\mu\text{-SPh})(\text{P}^n\text{Bu}_3)_2]$	-138.7	3939	
trans- $[\text{Pt}_2\text{Cl}_2(\mu\text{-SPh})_2(\text{PMe}_3)_2]$	-158.7	3157	*
trans- $[\text{Pt}_2\text{Cl}_2(\mu\text{-SPh})_2(\text{PEt}_3)_2]$	-129.1	3181	
trans- $[\text{Pt}_2\text{Cl}_2(\mu\text{-SPh})_2(\text{P}^n\text{Pr}_3)_2]$	-138.2	3156	*
$[\text{Pt}_2(\mu\text{-SPh})_2(\text{PEt}_3)_4](\text{BF}_4)_2$	-124.8	2881	
$[\text{Pd}_2(\mu\text{-SPh})_2(\text{PEt}_3)_4](\text{BF}_4)_2$	-115.8		
$[\text{Pd}_2(\mu\text{-Cl})(\mu\text{-SPh})(\text{PPh}_3)_4](\text{BF}_4)_2$	-103.8, -107.9		

Table 2. $^{31}\text{P}\{^1\text{H}\}$ NMR Parameters for Chloro-Bridged Dimers Used as Reactants

	δ (ppm)	$^1\text{J}(\text{Pt-P})$ (Hz)
trans- $[\text{Pt}_2\text{Cl}_2(\mu\text{-Cl})(\text{PEt}_3)_2]$	-129.3	3831
trans- $[\text{Pt}_2\text{Cl}_2(\mu\text{-Cl})(\text{P}^n\text{Bu}_3)_2]$	-137.2	3814
$[\text{Pt}_2(\mu\text{-Cl})_2(\text{PEt}_3)_4](\text{BF}_4)_2$	-121.3	3582
$[\text{Pd}_2(\mu\text{-Cl})_2(\text{PEt}_3)_4](\text{BF}_4)_2$	-92.6	
$[\text{Pd}_2(\mu\text{-Cl})_2(\text{PPh}_3)_4](\text{BF}_4)_2$	-101.8	

* Reference 17.

II-B-2. ^{31}P and ^{195}Pt NMR Spectra of $[\text{Pt}_3\text{S}_3(\text{PMe}_2\text{Ph})_6](\text{BET}_4)_2$

The trinuclear complex $[\text{Pt}_3\text{S}_2(\text{PMe}_2\text{Ph})_6](\text{BET}_4)_2$ has four isotopomers IV to VII shown in schematic diagrams (Figure 8), along with their natural abundances. In the diagram, the complex is viewed from above the plane of the Pt_3 ring to simplify the drawing. The six phosphorus atoms occupy positions above and below the plane of the ring.

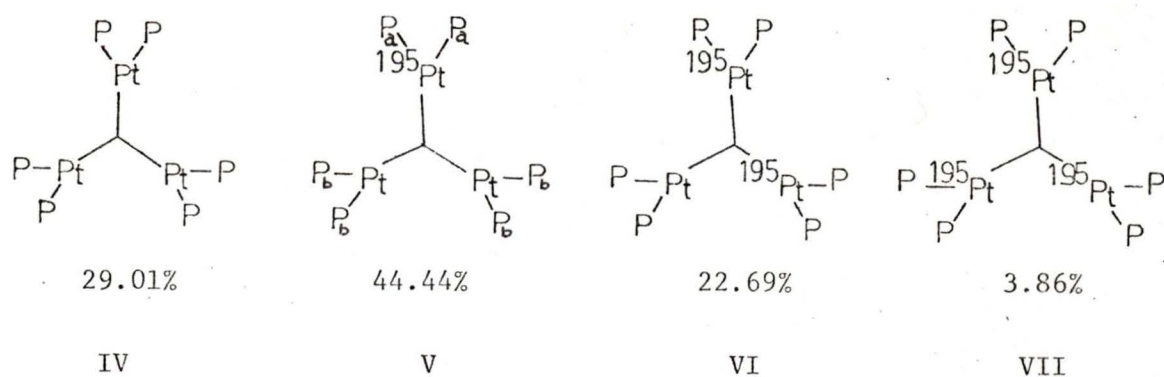

Figure 8. Isotopomers and their natural abundances of $[\text{Pt}_3\text{S}_2\text{L}_6]^{2+}$.

The relative abundances of the isotopomers were calculated below (9), using the natural abundances of magnetically active and non-active platinum isotopes as 33.8% and 66.2%, respectively.

$$\begin{aligned}
 \text{IV.} & \quad 0.662^3 \times 100 = 29.01 \\
 \text{V.} & \quad (0.662^2 \times 0.338 \times 100) \times 3 = 44.44 \\
 \text{VI.} & \quad (0.662 \times 0.338^2 \times 100) \times 3 = 22.69 \\
 \text{VII.} & \quad 0.338^3 \times 100 = 3.86
 \end{aligned}
 \tag{9}$$

In the experimental spectra, the isotopomers IV, V and VI are detected, but VII has too small a natural abundance to be significant. The spectral features of the first three isotopomers were studied and assigned individually to analyse the ^{31}P and ^{195}Pt spectra. The analysis was simplified by making two assumptions. Firstly, one-bond platinum-phosphorus coupling constants are about 3 to 4 KHz. Secondly, for this complex, four-bond phosphorus-phosphorus coupling constants are much smaller than three-bond platinum-phosphorus coupling constants and are not resolved. The spectrum of each relevant isotopomer was then simulated using the computer program PANIC (Parameter Adjustment in NMR by Iteration Calculation) produced by Bruker Spectrospin (Canada) Ltd.

^{31}P NMR

The $^{31}\text{P}\{^1\text{H}\}$ NMR spectrum of the trinuclear complex is shown in Figure 9. As explained in Chapter II-B, it is necessary to consider each isotopomer separately. The interpretations of the isotopomer spectra are as follows.

Isotopomer IV has all the six phosphorus atoms attached to magnetically non-active platinum ($I=0$), and gives a spectrum which consists of a singlet. This resonance is the largest signal in the center of the experimental spectrum at -157.68 ppm. The multiplet features of the experimental spectrum arise from V and VI. The pattern due to V is particularly intense because it is the most abundant isotopomer (44.44%). The spin system of V is $AA'A''\dots\dots A''''X$. All

the P nuclei are magnetically non-equivalent because each nucleus sees ^{195}Pt and other phosphorus nuclei differently. Applying the assumption described earlier that $^4J(\text{P-P})$ is zero, the spin system is reduced to a pseudo first order $A_2A'_4X$ type. The most intense signals in the ^{195}Pt satellites labeled a are due to P_a of V with one-bond platinum-phosphorus coupling of 3201 Hz. A large resonance of P_b appears as a doublet very close to the resonance from IV, due to the coupling with ^{195}Pt which is three bonds apart ($^3J(\text{Pt-P})=25$ Hz). Isotopomer VI has a spin system $AA'A''\dots A''''X'$ which is simplified to $A_2A'_4XX'$ by using the assumption. The resonances labelled b in Figure 9 are due to VI. The spectrum from VI is non-first order. It involves the coupling between two platinum nuclei separated by two bonds. However, it is very difficult to calculate $^2J(\text{Pt-Pt})$ from this spectrum. This value was estimated from the ^{195}Pt NMR spectrum, which will be discussed in the next section. The spectra of V and VI were simulated from these coupling constants (Figure 10). It is clear that super-imposition of these two spectra gives a satisfactory simulation of the experimental spectrum in Figure 9.

^{195}Pt NMR

The $^{195}\text{Pt}\{^1\text{H}\}$ NMR spectrum of the trinuclear complex appears much simpler than its ^{31}P NMR spectrum (Figure 11). The fine structures are derived from the coupling between the metal and phosphorus nuclei. As for the analysis of the ^{31}P NMR spectrum, it is assumed that the phosphorus-phosphorus couplings are much smaller than metal-phosphorus

and metal-metal couplings and are not resolved in the experimental spectrum.

The ^{195}Pt NMR spectrum is a super-imposition of the spectra from V and VI. The spectrum from VII is not detectable in this scale because of its low natural abundance. The peaks labelled a in Figure 11 belong to the spectrum from V. The one-bond metal- P_a coupling of V is pseudo first order. The triplet is due to the coupling between the platinum and two equivalent phosphorus nuclei P_a . In a strict sense, those two phosphorus nuclei are magnetically non-equivalent (see the last section), but they are chemically equivalent and coupled to each other and hence give a simple triplet. The separations between the lines of the triplet differ by 2 Hz, and the average of the two gives 3201 Hz which is the same as the value obtained for $^1\text{J}(\text{Pt-P})$ coupling constant obtained from the ^{31}P spectrum. Each signal is further complicated by three-bond metal-phosphorus couplings. This is detected only as a broadening of each line. The central line is larger than expected from the first order analysis in which the triplet should have an intensity ratio 1:2:1. This feature indicates the triplet of V overlaps with the spectrum from VI. The peaks labelled b in Figure 11 are from the spectrum of VI which contains the metal-metal coupling information. As it was mentioned in the last section, the spin system of VI is $\text{A}_2\text{A}'_4\text{XX}'$, and non-first order analysis is required for this spin system. The separations between three pairs of b's are 483.9 Hz, 452.1 Hz and 468.4 Hz, from left to right of the spectrum. This large irregularity is due to the inaccuracy of the plotting. The first step in solving this problem is to consider that the platinum

nucleus couples with two adjacent equivalent phosphorus atoms to give a triplet which is further split into doublets by the coupling between the two non-equivalent platinum atoms. The two-bond platinum-platinum coupling constant is then somewhere between 452 Hz and 484 Hz. This crude analysis was proved reasonable, when it was tested by simulation of the spectrum using PANIC. The spectrum of VI was simulated with an estimated value of ${}^2J(\text{Pt-Pt})=480$ Hz. The simulated spectra (Figure 12) agree reasonably well with the observed spectrum (Figure 11). The same value for the ${}^2J(\text{Pt-Pt})$ coupling constant was used to simulate the ${}^{31}\text{P}$ spectrum of VI in Figure 10, which also proved the validity of the analysis.

The coupling mechanism is known to depend on the s-coefficients in the polarizability term.²⁹ The parameters $J(\text{Pt-P})$ and P-Pt bond length are believed to have some correlation. Considering this, it seems reasonable to expect a source of metal-metal bond information in the parameters ${}^1J(\text{Pt-Pt})$ and ${}^2J(\text{Pt-Pt})$ coupling constants of polymeric platinum complexes. A recent review by Pregosin summarizes research done in this field.³² Theoretically speaking, the degree of metal-metal interactions should be reflected in the size of coupling constants. However, it was found that there is no direct relationship between $J(\text{Pt-Pt})$ parameters and platinum bond distances which are obtained by X-ray techniques. The reason for this lies probably in the nature of metal-metal bonds. Unlike platinum-phosphorus bonds where the s character of phosphorus is important for the bonding, metal-metal bonds involve significant degrees of p and d characters. The relation between

the coupling mechanism and p- or d-coefficients is not known at the present time.

Conclusion

The size of $^1J(\text{Pt-P})$ coupling constant is related to the number of covalent bonds on sulfur for complexes in which phosphine ligands are trans to sulfur atoms. When the sulfur ligand has two covalent bonds, $^1J(\text{Pt-P})$ is about 2600-2800 Hz: $[(\text{dppe})\text{PtS}_4]$, 2805 Hz; $[\text{Pt}_2\text{S}_2(\text{PMe}_2\text{Ph})_4]$, 2679 Hz³³. If the sulfur ligand has three covalent bonds, the value is significantly larger and falls between 3100 Hz and 3200 Hz, for both triply bridging sulfur ligand and alkylthio-bridging ligand: trans- $[\text{Pt}_2\text{Cl}_2(\mu\text{-SPh})_2\text{L}_2]$, 3150-3200 Hz (Table 1 and reference 33); $[\text{Pt}_3\text{S}_2\text{L}_6]^{2+}$, 3201 Hz. The only known platinum complex with sulfur having four chemical bonds is thioether bridged complex $[\text{Pt}_2\text{Br}_4(\text{SEt}_2)_2]^{20}$, and the thioether complex containing terminal phosphine ligands has not been isolated.

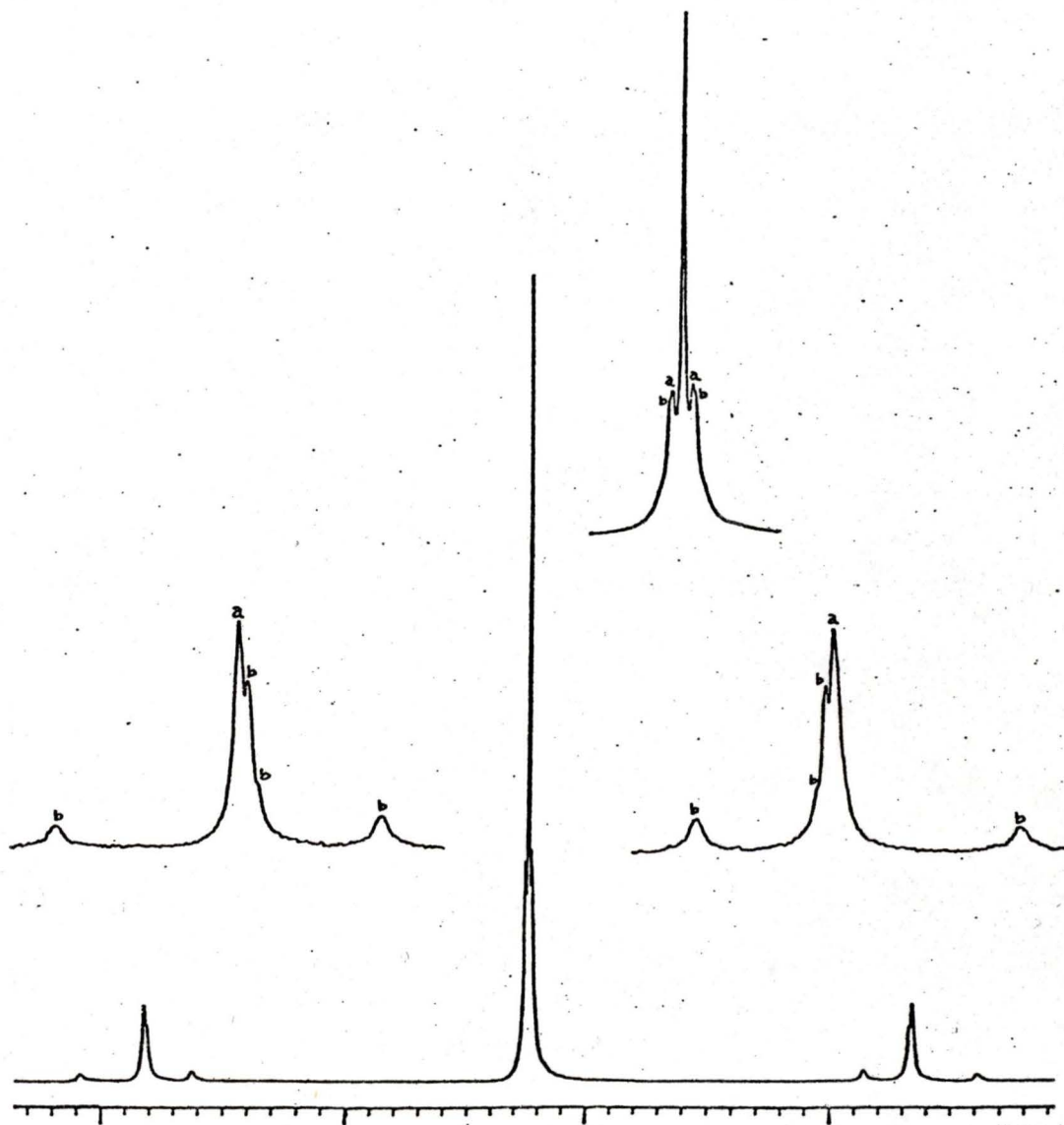

Figure 9. $^{31}\text{P}\{^1\text{H}\}$ NMR spectrum of $[\text{Pt}_3\text{S}_2(\text{PMe}_2\text{Ph})_6](\text{BET}_4)_2$.

a: spectrum from V; b: spectrum from VI.

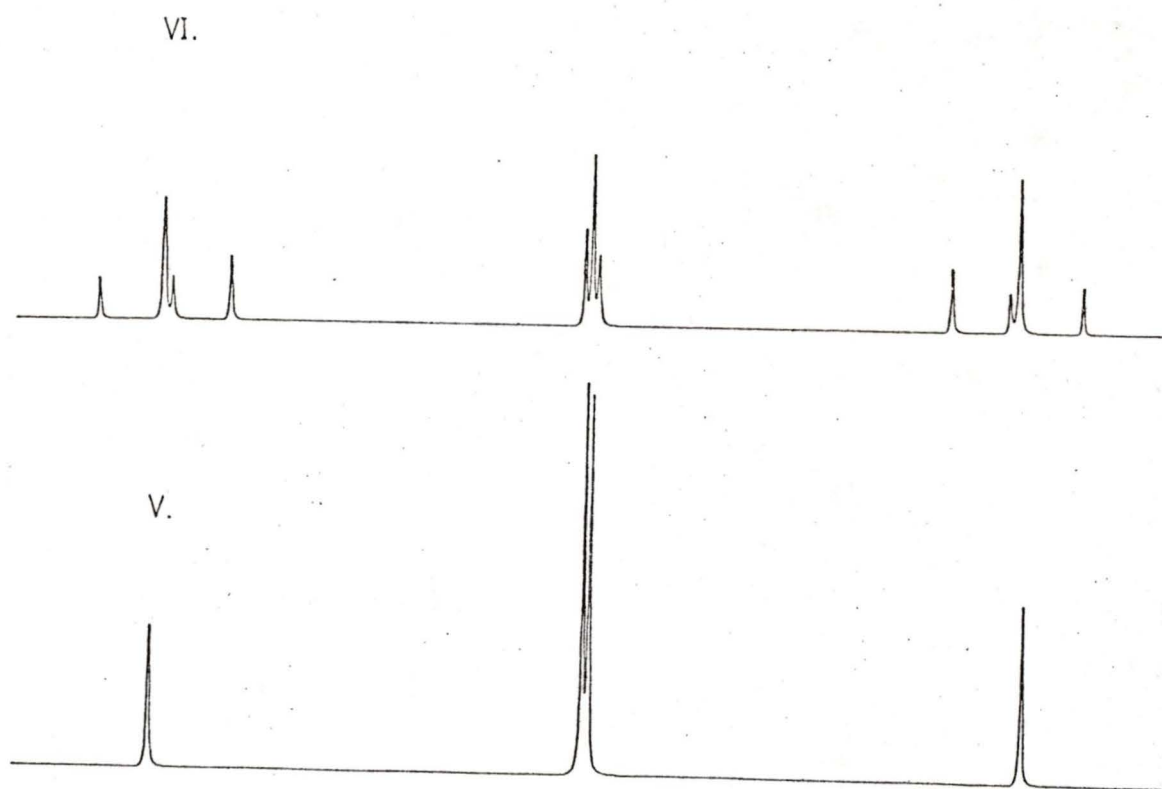
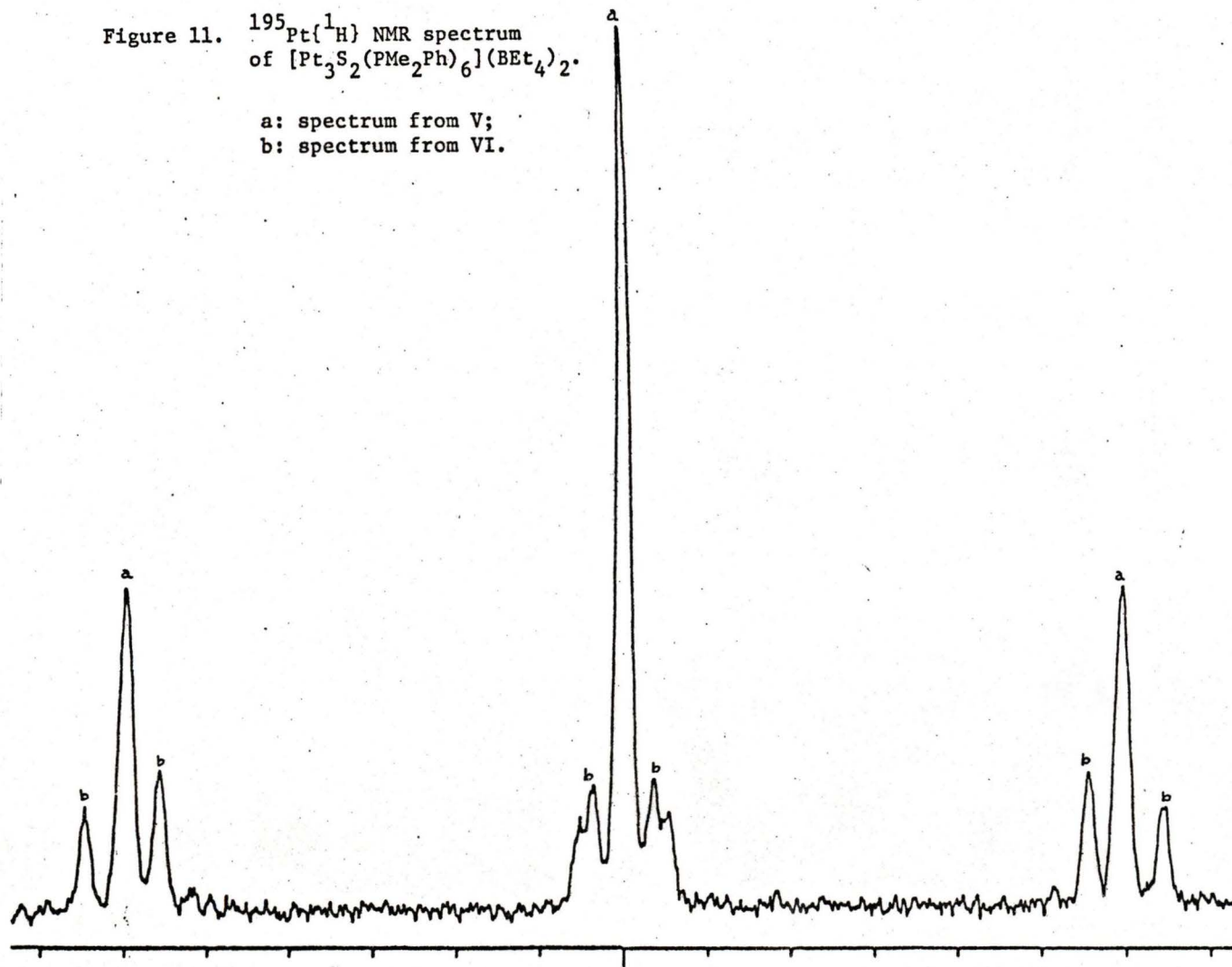

Figure 10. The simulated ^{31}P spectra for V and VI.

Figure 11. $^{195}\text{Pt}\{^1\text{H}\}$ NMR spectrum
of $[\text{Pt}_3\text{S}_2(\text{PMe}_2\text{Ph})_6](\text{BET}_4)_2$.

a: spectrum from V;
b: spectrum from VI.



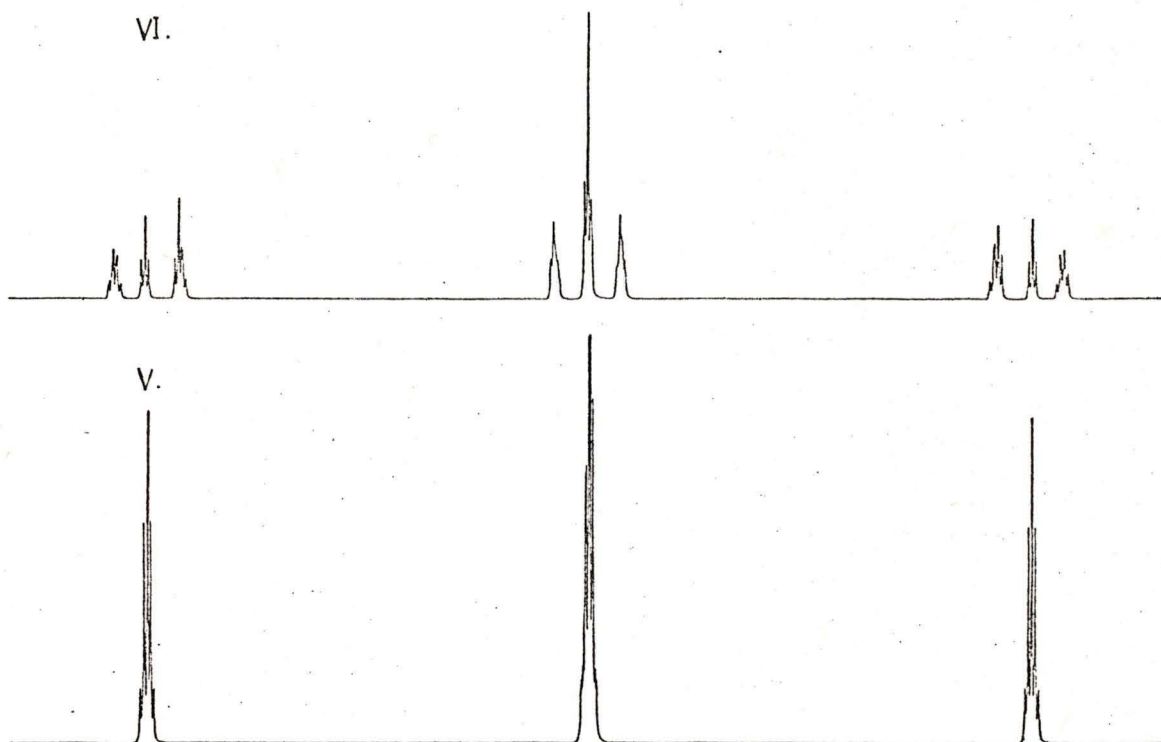

Figure 12. The simulated ^{195}Pt spectra for V and VI.

EXPERIMENTAL

1. NMR

The $^{31}\text{P}\{^1\text{H}\}$ and $^{195}\text{Pt}\{^1\text{H}\}$ NMR spectra were measured in CH_2Cl_2 solution in 10 mm tubes using Nicolet TT 14 and Bruker WM250 NMR spectrometers operating at 53.54 MHz for ^{195}Pt and 101.27 MHz for ^{31}P nuclei. The chemical shifts of ^{31}P spectra were measured relative to trimethylphosphite. The ^{195}Pt spectrum was taken without a reference, placing the chemical shift of the most intense line close to zero. Negative chemical shifts indicate upfield from the reference, adopting the most popular chemical shift convention of the present time.³⁴ The ^1H NMR spectra were measured relative to tetramethylsilane using a Perkin-Elmer R32 (90MHz) spectrometer.

Spectral simulations were made using the computer program PANIC produced by Bruker Spectrospin (Canada) Ltd.

2. Preparations of Me_3SiSPh and $\text{Me}_3\text{SiPPh}_2$

Both trimethylthiosilane and trimethyldiphenylphosphinosilane are unstable to oxygen and moisture. Diethyl ether and tetrahydrofuran were dried over potassium in the presence of benzophenone as an indicator, and were distilled under nitrogen just prior to use. Tert-butylchloride and trimethylchlorosilane were dried over 4 Å molecular sieve and were distilled under nitrogen. Thiophenol was dried over 4 Å molecular sieve

and was degassed by freeze-and-thaw technique. Glassware was dried in an oven and then by heating with flame under vacuum. All the manipulations were carried out under a nitrogen atmosphere.

Me_3SiSPh

Clean dry magnesium turnings (5.35 g, 0.22 mol) were stirred with 1,2-dichloroethane (1 ml) in dry ether (200 ml) for 10 min under a nitrogen atmosphere in a 1 liter round-bottomed flask fitted with a dropping funnel and a condenser. A solution of PhBr (21 ml) in ether was added dropwise to the magnesium through the dropping funnel over a period of 3 h. The resulting brown solution was refluxed for 20 min to ensure completion of the reaction. Benzene thiol (20.5 ml) was added dropwise to the PhMgBr solution without removing the unreacted magnesium turnings, maintaining the reflux caused by the heat of reaction at a reasonable rate. The resulting mixture of pale yellow solution and gray solid was refluxed for 3 h during which the solid changed its color to white. To the suspension of PhSMgBr in ether was added a solution of Me_3SiCl (25.2 ml) in ether (5 ml) slowly. The reaction mixture was refluxed for 3 h. The pale yellow solution of Me_3SiSPh was separated from a white solid. Some more Me_3SiSPh was extracted from the solid with ether. The solvent was removed by distillation under nitrogen pressure. Pure Me_3SiSPh (36 g, 98.7%) was obtained from the distillation of the residual oil at 0.3 mmHg (b.p. 40-43°/0.3mmHg; ^1H NMR: δ 0.3 ppm (singlet), δ 7.4 ppm (multiplet)).



Lithium metal (0.55 g, 0.08 mol) was added to a solution of PPh_3 (10.5 g, 0.04 mol) in dry THF (25 ml) in a three-necked, round-bottomed flask equipped with a condenser. An exothermic reaction took place and the solution was stirred for 2 h to give a mixture of LiPPh_2 and LiPh . Tert-butyl chloride was syringed slowly into the mixture to remove LiPh . A solution of Me_3SiCl (5 ml) in THF was added dropwise to the LiPPh_2 solution to give a pale yellow solution of $\text{Me}_3\text{SiPPh}_2$. The product was separated from the solvent and byproducts by filtration followed by low-pressure distillation. The literature quotes the boiling point of $\text{Me}_3\text{SiPPh}_2$ as 126–127°/1 mmHg.³⁵ However, the fraction collected within this range contained PPh_2H impurity whose boiling point is 112–113°/1.5 mmHg³⁶ ($^{31}\text{P}\{^1\text{H}\}$ NMR: $\text{Me}_3\text{SiPPh}_2$, δ -196.4 ppm; PPh_2H , δ -180.2 ppm).

3. Preparation of Mercaptide Bridged Complexes

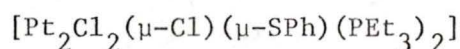

To a solution of $[\text{Pt}_2\text{Cl}_4(\text{PET}_3)_2]$ (0.5 g, 0.65 mmol) in CH_2Cl_2 (20 ml) was added Me_3SiSPh (0.119 g, 0.65 mmol) in CH_2Cl_2 (3 ml). The mixture was stirred for 15 h at room temperature. No change in color was observed. The solution was dried in vacuo to give a yellow powder which was washed well with ether and was recrystallised from CH_2Cl_2 to give yellow needles of $[\text{Pt}_2\text{Cl}_3(\text{SPh})(\text{PET}_3)_2]$ (0.474 g, 86.5 % yield) (m.p. 248–249°, $^{31}\text{P}\{^1\text{H}\}$ NMR: δ -130.6 ppm, $^1\text{J}(\text{Pt-P})$ 3965 Hz; Found: C, 25.78; H, 4.05,

$C_{18}H_{35}Cl_3P_2Pt_2S$ requires C, 25.67; H, 4.20).

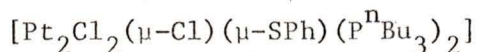

A solution of $[Pt_2Cl_4(P^nBu_3)_2]$ (0.2 g, 0.21 mmol) in CH_2Cl_2 (8 ml) was stirred with Me_3SiSPh (0.087 g, 0.48 mmol) in CH_2Cl_2 (8 ml) for 2 h at room temperature. The solution was dried in vacuo to give a yellow oil. The product was recrystallised from CH_2Cl_2 /ether system to give yellow crystals of $[Pt_2Cl_3(SPh)(P^nBu_3)_2]$ (0.181 g, 85.7 %) (m.p. 141-142°, $^{31}P\{^1H\}$ NMR: δ -138.7 ppm, $^1J(Pt-P)$ 3939 Hz).



To a solution of $[Pt_2Cl_3(SPh)(PEt_3)_2]$ (0.470 g, 0.56 mmol) in CH_2Cl_2 (15 ml) was added 1.3 molar equivalents of Me_3SiSPh (0.133 g) dropwise. The reaction mixture was stirred for 3 h at room temperature. The product was recrystallised from CH_2Cl_2 to give yellow crystals of trans- $[Pt_2Cl_2(\mu-SPh)_2(PEt_3)_2]$ ($^{31}P\{^1H\}$ NMR: δ -129 ppm, $^1J(Pt-P)$ 3181 Hz).

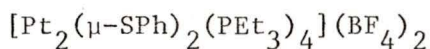

A solution of Me_3SiSPh (0.33 g, 0.18 mmol) in CH_2Cl_2 (3 ml) was added dropwise to $[Pt_2Cl_2(PEt_3)_4](BF_4)_2$ (0.197 g, 0.18 mmol) in CH_2Cl_2 (5 ml). The mixture was stirred for 14 h at room temperature. The solution was dried in vacuo to give a white oil which was then dissolved in MeOH (8 ml) and ether (8 ml). Hexane was added to the solution until a very small amount of precipitation started. The system was allowed to stand in a deep-freezer over night to give white crystals which were

separated from the solution, washed with hexane and dried. The recrystallization from CH_2Cl_2 /hexane gave white crystals of $[\text{Pt}_2(\text{SPh})_2(\text{PEt}_3)_4](\text{BF}_4)_2$ (73 mg, 32.6 %) (m.p. 278–283°, $^{31}\text{P}\{^1\text{H}\}$ NMR: δ -124.8 ppm, $^1\text{J}(\text{Pt-P})$ 2881 Hz; Found: C 34.41, H, 5.76. $\text{C}_{36}\text{H}_{70}\text{B}_2\text{F}_8\text{P}_4\text{Pt}_2\text{S}_2$ requires C, 34.45; H, 5.63).

Subsequent work-up of the solution separated from the solid yielded pale yellow crystals of *cis*- $[\text{PtCl}_2(\text{PEt}_3)_2]$ (58 mg, 66.3 %) ($^{31}\text{P}\{^1\text{H}\}$ NMR: δ -130.9 ppm, $^1\text{J}(\text{Pt-P})$ 3508 Hz).

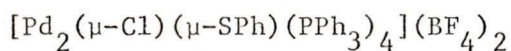

To a solution of $[\text{Pd}_2\text{Cl}_2(\text{PPh}_3)_4](\text{BF}_4)_2$ (0.300 g, 0.20 mmol) in CH_2Cl_2 (20 ml) was added a solution of Me_3SiSPh (0.049 g, 0.26 mmol) in CH_2Cl_2 (3 ml), which was then stirred for 16 h at room temperature. The solvent was removed in vacuo to give an orange solid which was dissolved in CH_2Cl_2 (30 ml) and ether (30 ml). To the system was added hexane (10 ml), which was then kept in a deep-freezer for three days to give orange hexagonal plates of $[\text{Pd}_2\text{Cl}(\text{SPh})(\text{PPh}_3)_4](\text{BF}_4)_2$ (0.268 g, 85.2 %) (m.p. 212–215°, $^{31}\text{P}\{^1\text{H}\}$ NMR: δ -103.8 ppm, -107.9 ppm; Found: C, 58.44; H, 4.05. $\text{C}_{78}\text{H}_{65}\text{B}_2\text{ClF}_8\text{P}_4\text{Pd}_2\text{S}$ requires C, 59.32; H, 4.16).

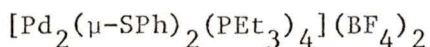

To a solution of $[\text{Pd}_2\text{Cl}_2(\text{PEt}_3)_4](\text{BF}_4)_2$ (0.122 g, 0.13 mmol) in CH_2Cl_2 (4 ml) was added a solution of Me_3SiSPh (0.024 g, 0.13 mmol) in CH_2Cl_2 (3 ml), and the reaction mixture was stirred for 15 h at room

temperature. The solvent was removed to give an orange oil which was then dissolved in methanol(7 ml) and ether(7 ml). Hexane was added until precipitate just started to form. The system was kept in a deep-freezer overnight to give a mixture of orange solution and orange crystals of $[\text{Pd}_2(\text{SPh})_2(\text{PPh}_3)_4](\text{BF}_4)_2$ (65 mg, 30 %) (m.p. 224.227° , $^{31}\text{P}\{^1\text{H}\}$ NMR: δ -115 ppm, Found: C, 38.85; H, 6.59. $\text{C}_{36}\text{H}_{70}\text{B}_2\text{F}_8\text{P}_4\text{Pd}_2\text{S}_2$ requires C, 40.13; H, 6.56).

The removal of the solvent from the solution gave an orange oil which was recrystallized from CH_2Cl_2 /ether to give yellow crystals of trans- $[\text{PdCl}_2(\text{PEt}_3)_2]$ (46 mg, 67.5 %).

4. Preparation of $[\text{Pt}_3\text{S}_2(\text{PMe}_2\text{Ph})_6](\text{BEt}_4)_2$

The experiments were carried out under dry N_2 . Lithium sulfide was prepared from elemental sulfur and LiEt_3BH . Sublimed sulfur was obtained from Matheson Coleman & Bell and LiEt_3BH from Aldrich as 1.0 M THF solution; both of which were used without further purification.

To a slurry of sulfur(118 mg) in THF was added LiEt_3BH (8 ml) dropwise to give a clear yellow solution of Li_2S . The solution was stirred for 15 min to ensure completion of the reaction. The Li_2S solution was added dropwise to a suspension of cis- $[\text{PtCl}_2(\text{PMe}_2\text{Ph})_2]$ (2 g) in nitrogen purged EtOH(70 ml). The mixture was stirred for 3 h at room temperature to give a yellow solution and yellow solid. The solid was filtered off and washed with water and EtOH. The product was recrystallised twice from CH_2Cl_2 /EtOH. Air-stable pale yellow crystals of $[\text{Pt}_3\text{S}_2(\text{PMe}_2\text{Ph})_6]$ -

(BEt₄)₂ were obtained (1.811 g; 85 %) (m.p. 147-150°, ¹H NMR: δ 1.65 ppm triplet of doublets, δ 7.5 ppm broad peak; ³¹P{¹H} NMR: δ -159 ppm multiplet, ¹J(Pt-P) 3199 Hz; Found: C, 44.3; H, 6.0; S, 4.2. C₆₄H₁₀₆P₆-Pt₃S₂B₂ requires C, 44.4; H, 6.2; S, 3.7).

5. Preparation of [(dppe)PtS₄]

To a solution of [Pt(dppe)₂] (260 g) in degassed benzene (10 ml) was added elemental sulfur (49 mg) in benzene (5 ml) under nitrogen. Orange solids precipitated out after a few minutes of stirring. The mixture was stirred for ½ h at room temperature. The orange solids were filtered off, washed with a small amount of toluene, and dried. The air stable product was recrystallized from CH₂Cl₂/MeOH to give orange needles of platinum complex (m.p. 280-284, ³¹P{¹H} NMR: δ -91.1 ppm, ¹J(Pt-P) 2805 Hz; Found: C, 41.9; H, 2.99. C₂₆H₂₄P₂PtS₄ requires C, 41.43; H, 3.21). The product is not likely to be the tetrasulfide platinum complex, because the discrepancies of the elemental analysis results are too large (see also the X-ray studies of this product in Chapter III-B-3).

Table 3. Mercaptide Bridged Complexes of Pt(II) and Pd(II)

Molecular Formula	Color	C	H	Melting Point	$^{31}\text{P}\{^1\text{H}\}$ NMR		Yield(%)
		Anal. (Calc.)	Anal. (Calc.)		δ (ppm)	1J (Hz)	
$[\text{Pt}_2\text{Cl}_3(\text{SPh})(\text{PEt}_3)_2]$	pale yellow	25.78(25.67)	4.05(4.20)	248-249	-130.59	3965	86.5
$[\text{Pt}_2\text{Cl}_3(\text{SPh})(\text{PBu}_3)_2]$	yellow			141-142	-138.70	3939	85.7
$[\text{Pt}_2(\text{SPh})_2(\text{PEt}_3)_4](\text{BF}_4)_2$	white	34.41(34.45)	5.76(5.63)	278-283	-124.83	2881	32.6
$[\text{Pd}_2(\text{SPh})_2(\text{PEt}_3)_4](\text{BF}_4)_2$	orange	38.85(40.13)	6.59(6.56)	224-227	-115.75		30.0
$[\text{Pd}_2\text{Cl}(\text{SPh})(\text{PPh}_3)_4](\text{BF}_4)_2$	orange	58.44(59.32)	4.05(4.16)	212-215	-103.77		85.2
					-107.88		

CHAPTER III

X-RAY DIFFRACTION STUDIES

The structure of complexes $\text{cis-}[\text{Pt}_2\text{Cl}_2(\mu\text{-Cl})(\mu\text{-SPh})(\text{PEt}_3)_2]$, $[\text{Pt}_3\text{S}_2(\text{PMe}_2\text{Ph})_6](\text{BEt}_4)_2$ and $[(\text{dppe})\text{PtS}_4]$ were investigated using single crystal X-ray diffraction techniques. The structure of the first two molecules were solved, but that of the last complex remained unsolved due to crystallographic problems. The structure analyses were done by methods which were standard in Dr. G. W. Bushnell's laboratory. These techniques along with the instrumentation are described in Chapter III-B.

III-A. Description and Discussion of the Structures

III-A-1. Structure of $[\text{Pt}_2\text{Cl}_2(\mu\text{-Cl})(\mu\text{-SPh})(\text{PEt}_3)_2]$

The crystal structure consists of a discrete dinuclear entity of the formula given in the title. The asymmetric unit is one molecule whose structure is presented in Figure 13 and its schematic diagram in Figure 14, along with the numbering system used elsewhere. All the hydrogen atoms are excluded from the drawing. Table 4 lists the bonded interatomic distances and Table 5 the bond angles. The results of the mean plane calculation are shown in Table 6. The coordination around each platinum atom is almost square planar. The platinum-platinum distance is 3.828 Å. The molecule has a cis configuration which agrees with the

results obtained from the dipole moment measurement¹⁵ and $^{31}\text{P}\{^1\text{H}\}$ NMR (Chapter II-B-1). The bond angles Pt(1)-S(1)-C(1) and Pt(2)-S(1)-C(1) are $109.0(9)^\circ$ and $104.8(10)^\circ$, respectively. These values show that the sulfur atom of phenylthio-bridge is approximately tetrahedral with the lone pair of electrons occupying the fourth position. The Pt(1)-S(1)-Pt(2) bond angle is $95.6(3)^\circ$ which is much closer in value to the square planar angle than to the tetrahedral angle. This arises from the geometric requirement to join two square planes of platinum atoms. The dihedral angle between the two least squares coordination planes is 157.1° . This indicates that the $\text{Pt}_2\text{Cl}_3\text{P}_2\text{S}$ unit is not planar but bent by 22.9° , due to the tetrahedral bridging sulfur. The phenylthio-group is cis to triethylphosphines, though such a geometry is not expected from the minimum steric effects between these bulky groups. One of the reasons for the stability of this structure is explained in terms of trans-influence of the ligands about the platinum atom.¹⁵ Groups of high trans-influence in trans position to each other introduce configurational instability into the molecule. Both sulfur and phosphorus have considerably high trans-influences than chlorine. The cis geometry which has low trans influence chlorine rather than phosphine trans to sulfur is favoured in terms of this effect. The benzene ring of phenylthio-bridge is almost perpendicular to the plane of the $\text{Pt}_2\text{Cl}_3\text{P}_2\text{S}$ unit so as to minimize steric hindrance.

The average bond distance between platinum and chloride (bridge) is $2.418(9) \text{ \AA}$ which is very close to the value 2.40 \AA obtained for $[\text{Pt}(\mu\text{-Cl})_2(\text{PEt}_3)_4](\text{BF}_4)_2$.³⁷ The introduction of sulfur into the two-

platinum-two-bridging ligand ring does not seem to affect Pt-bridging chloride bond lengths. The average bond distance between platinum and terminal chloride is 2.313(10) Å which is significantly shorter than the Pt-Cl(bridging) bond distance. This is expected as bond lengthening is associated with bridging. However, such an effect seems negligible or absent in Pt-S(bridging) bonds of the title complex. The average value of Pt-S bond lengths is 2.279(8) Å. This is similar to that of the thioether-bridged complex $[\text{Pt}_2\text{Br}_4(\text{SEt}_2)_2]$: 2.23(5) Å,³⁸ and much shorter than the average Pt-S(bridging) distance of *cis*- $[\text{Pt}_2(\mu\text{-SCH}_2\text{Ph})_2(\text{SCH}_2\text{Ph})_2(\text{PMePh}_2)_2]$: 2.351(4) Å.³⁹ The average Pt-S(terminal) distance of the last complex is 2.330(5) Å, which is longer than the Pt-S(bridging) distance of the title complex. It might be argued that it is due to the higher trans influence of bridging sulfur compared to bridging chloride. However, the complex *cis*- $[\text{PtCl}_2(\text{SC}_6\text{H}_4\text{Cl})_2]$ which has sulfur trans to chlorine has the average Pt-S distance of 2.285(7) Å.⁴⁹

The two PEt_3 groups are arranged in such a way as to minimize the steric crowding. This causes the slight distortion of the square planar bond angles about platinum. Each PEt_3 can be described as a W-shaped unit having a L-shaped unit attached to the center approximately perpendicular to the plane of the W. The W-shaped unit, consisting of C(14), C(13), P(1), C(15) and C(16), is approximately perpendicular to the square plane of Pt(1), avoiding the steric hindrance with Cl(1). This causes the L-shaped unit consisting of C(11) and C(12) to come close to the phenyl group. This steric crowding makes the S(1)-Pt(1)-

P(1) angle to be widened to 95.3° , and the Cl(1)-Pt(1)-P(1) angle to close to 88.6° . The strain free Cl(1) leaves the Cl(3)-Pt(1)-Cl(1) angle(90.8°) very close to the square planar angle. In the other PEt_3 group, the W-shaped unit C(24)-C(23)-P(2)-C(25)-C(26) is arranged in such a manner as to minimize the steric crowding with the phenylthio-group, allowing the S(1)-Pt(2)-P(2) angle(90.4°) to remain close to 90° . The atom(21) interacts sterically with Cl(2) which results in an increase of the Cl(2)-Pt(2)-P(2) angle to 95.9° , and a decrease of the Cl(2)-Pt(2)-Cl(3) angle to 88.2° .

Figure 13. Molecular structure of $\text{cis-}[\text{Pt}_2\text{Cl}_3(\text{SPh})(\text{PET}_3)_2]$.

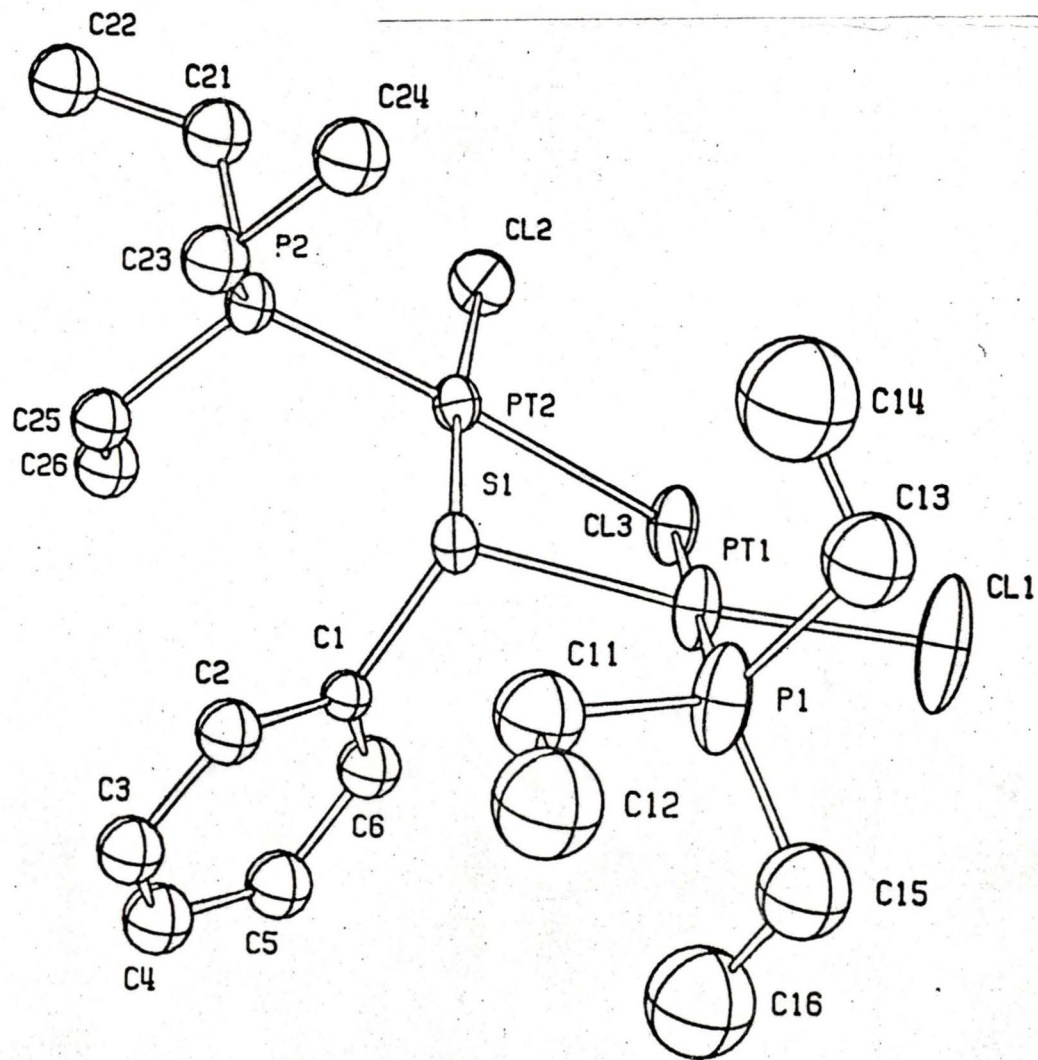

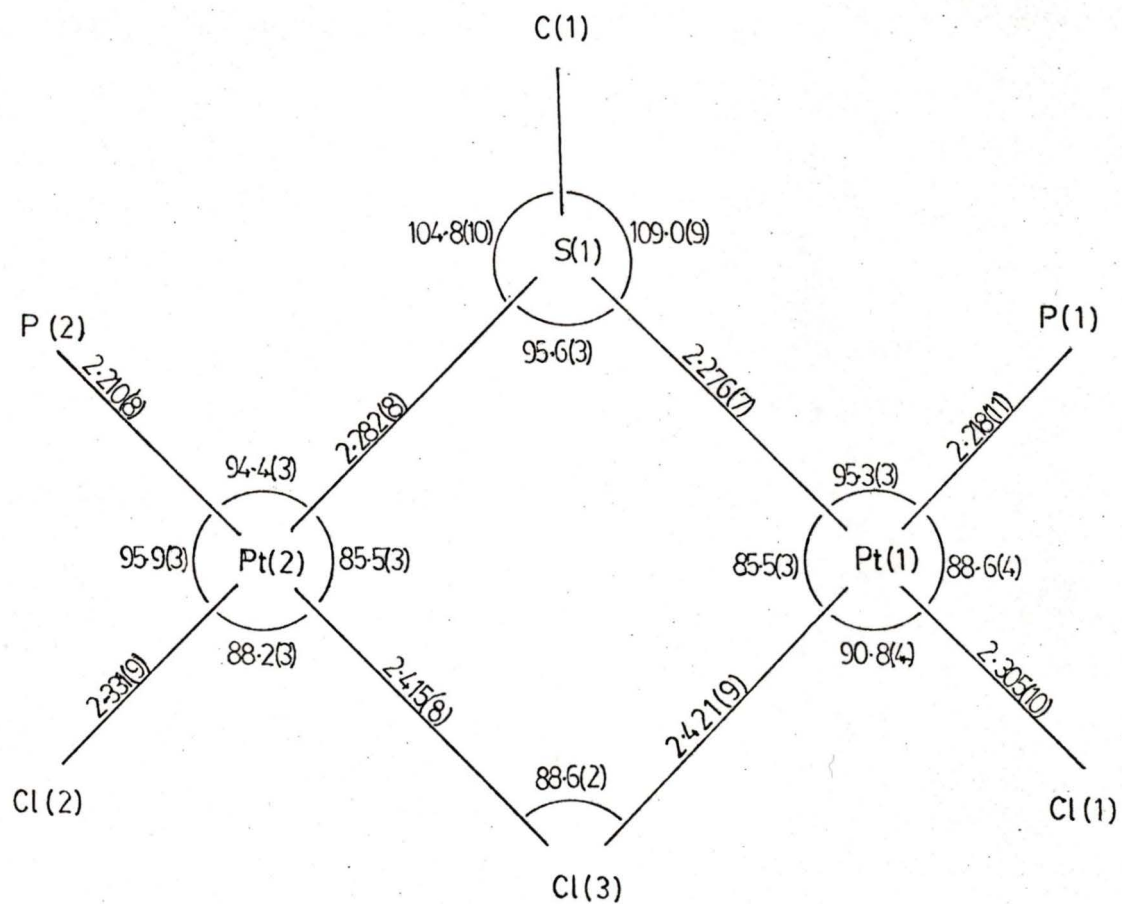

Figure 14. Schematic Molecular Structure Drawing of $\text{cis-}[\text{Pt}_2\text{Cl}_3(\text{SPh})(\text{PEt}_3)_2]$.

TABLE 4.

Interatomic distances (Å).

Atoms	Distance	Atoms	Distance
Cl(1) -Pt(1)	2.305(10)	Cl(2) -Pt(2)	2.331(9)
Cl(3) -Pt(1)	2.421(9)	Cl(3) -Pt(2)	2.415(8)
P(1) -Pt(1)	2.218(11)	P(2) -Pt(2)	2.210(8)
S(1) -Pt(1)	2.276(7)	S(1) -Pt(2)	2.282(8)
C(11) -P(1)	1.798(48)	C(21) -P(2)	1.879(37)
C(13) -P(1)	1.977(50)	C(23) -P(2)	1.812(34)
C(15) -P(1)	1.809(52)	C(25) -P(2)	1.819(30)
C(2) -C(1)	1.391(36)	C(5) -C(4)	1.401(42)
C(3) -C(2)	1.416(39)	C(6) -C(5)	1.416(39)
C(4) -C(3)	1.414(43)	C(6) -C(1)	1.399(36)
C(1) -S(1)	1.761(25)		
C(12) -C(11)	1.520(72)	C(22) -C(21)	1.528(47)
C(14) -C(13)	1.477(75)	C(24) -C(23)	1.631(45)
C(16) -C(15)	1.561(71)	C(26) -C(25)	1.506(43)

Estimated standard deviations are given in parentheses.

TABLE 5

Bond angles ($^{\circ}$).

Atoms	Angle	Atoms	Angle
(a) Angles at platinum.			
Cl(3) -Pt(1) -Cl(1)	90.8(4)	Cl(3) -Pt(2) -Cl(2)	88.2(3)
P(1) -Pt(1) -Cl(1)	88.6(4)	P(2) -Pt(2) -Cl(2)	95.9(3)
P(1) -Pt(1) -Cl(3)	178.1(4)	P(2) -Pt(2) -Cl(3)	175.5(3)
S(1) -Pt(1) -Cl(1)	173.2(5)	S(1) -Pt(2) -Cl(2)	173.8(3)
S(1) -Pt(1) -Cl(3)	85.5(3)	S(1) -Pt(2) -Cl(3)	85.5(3)
S(1) -Pt(1) -P(1)	95.3(3)	S(1) -Pt(2) -P(2)	90.4(3)
(b) Angles at chlorine and sulfur.			
Pt(2) -Cl(3) -Pt(1)	88.6(2)	Pt(2) -S(1) -Pt(1)	95.6(3)
C(1) -S(1) -Pt(1)	109.0(9)	C(1) -S(1) -Pt(2)	104.8(10)
(c) Angles at phosphorus.			
C(11) -P(1) -Pt(1)	113.3(18)	C(21) -P(2) -Pt(2)	113.8(11)
C(13) -P(1) -Pt(1)	108.0(16)	C(23) -P(2) -Pt(2)	116.6(12)
C(13) -P(1) -C(11)	110.1(21)	C(23) -P(2) -C(21)	105.0(15)
C(15) -P(1) -Pt(1)	111.6(17)	C(25) -P(2) -Pt(2)	112.5(10)
C(15) -P(1) -C(11)	106.0(22)	C(25) -P(2) -C(21)	105.3(16)
C(15) -P(1) -C(13)	107.7(24)	C(25) -P(2) -C(23)	102.3(15)
(d) Phenyl ring carbon angles.			
C(2) -C(1) -S(1)	116.2(21)	C(6) -C(1) -S(1)	122.2(21)
C(6) -C(1) -C(2)	121.5(26)	C(5) -C(4) -C(3)	121.7(32)
C(3) -C(2) -C(1)	121.7(28)	C(6) -C(5) -C(4)	120.4(31)
C(4) -C(3) -C(2)	116.4(29)	C(5) -C(6) -C(1)	117.6(28)
(e) The triethylphosphine carbon angles.			
C(12) -C(11) -P(1)	113.8(41)	C(22) -C(21) -P(2)	114.8(25)
C(14) -C(13) -P(1)	109.1(43)	C(24) -C(23) -P(2)	111.6(22)
C(16) -C(15) -P(1)	111.2(42)	C(26) -C(25) -P(2)	113.1(22)

Estimated standard deviations are given in parentheses.

Table 6. Mean Planes for $\text{cis-}[\text{Pt}_2\text{Cl}_2(\mu\text{-Cl})(\mu\text{-SPh})(\text{PEt}_3)_2]$

(a) Plane Definitions

Plane	Atoms	Description
1	Pt(1), Cl(1), Cl(3), P(1), S(1)	Square plane of Pt(1)
2	Pt(2), Cl(2), Cl(3), P(2), S(1)	Square plane of Pt(2)
3	C(1)-C(6)	Benzene ring

(b) Coefficients of Equations of Least-Squares Planes Through Selected Sets of Atoms: $Ax + By + Cz = D$ (Å)

Plane	A	B	C	D	χ^2 *
1	-0.0243	-0.9994	-0.0234	-3.5347	209.8028
2	0.3429	-0.9262	-0.1568	-2.1178	37.1790
3	0.9193	0.2790	-0.2776	3.9739	2.6994

* $\chi^2 = \sum_i (P_i^2 / \sigma^2(P_i))$ where P_i is the perpendicular distance of atom i from the plane.

(c) Perpendicular Distances of Atoms from the Planes

Plane	Atoms and Distances
1	Pt(1), 0.002(1); Cl(1), -0.168(14); Cl(3), 0.027(9); P(1), 0.051(14); S(1), -0.056(9)
2	Pt(2), -0.001(1); Cl(2), -0.009(9); Cl(3), 0.033(9); P(2), 0.038(9); S(1), -0.008(8)
3	Cl(3), 0.121(9); S(1), 0.071(7)

Angles between normals to the planes: 1,2 = 22.93°; 1,3 = 107.14°; 2,3 = 84.24°

III-A-2. Structure of $[\text{Pt}_3\text{S}_2(\text{PMe}_2\text{Ph})_6](\text{BEt}_4)_2$

The cationic complex $[\text{Pt}_3\text{S}_2(\text{PMe}_2\text{Ph})_6]^{2+}$ and the two anionic molecules BEt_4^- exist as separate entities in the crystal. The molecular structure is shown in Figure 15 along with the numbering system used elsewhere, and the schematic diagram in Figure 16. The interatomic distances, bond angles and the results of mean plane calculation are listed in Table 7, Table 8 and Table 9, respectively. The structure of the cationic complex is best described as three distorted square planar $\text{cis-PtS}_2\text{P}_2$ moieties combined together by sharing the two sulfur atoms. These planes are arranged in such a way as to achieve the minimum interactions. The angle between the square planes of Pt(1) and Pt(2) is 121.8° and that between the square planes of Pt(1) and Pt(1') is 116.4° . The central core made up of three platinum and two sulfur atoms shows trigonal bipyramidal structure. The three metal atoms occupy the three equatorial apices and the two sulfur atoms the axial apices. There is a two-fold symmetry axis passing through Pt(2) and the midpoint of Pt(1)-Pt(1'). The asymmetric unit is one half of the formula. The Pt_3 triangle is isosceles and the metal-metal distances are $3.182(1) \text{ \AA}$, 3.182 \AA and $3.108(1) \text{ \AA}$. The Pt(1)-Pt(1') is the shortest of these three. The two sulfur atoms are bound equally to the three metals. The S-Pt-S angles are $79.0(1)^\circ$, $79.0(1)^\circ$ and $79.6(1)^\circ$ which are sharper than the square planar angle 90° . This causes the widening of P-Pt-P bond angle to $96.9(1)^\circ$, $96.9(1)^\circ$ and $103.0(2)^\circ$. All the P-Pt-S angles remain close to 90° .

The X-ray diffraction studies of the analogous complexes $[\text{Pd}_3\text{S}_2(\text{PMe}_3)_6](\text{BPh}_4)_2$ ²⁰ and $[\text{Ni}_3\text{S}_2(\text{PEt}_3)_6](\text{BPh}_4)_2$ ²¹ were reported

previously. Their structures are very similar to that of the title complex. Each complex has the central unit M_3S_2 consisting of a metal triangle capped with triply bridging sulfur atoms above and below the plane of the triangle. Structural similarities and differences of these complexes are discussed below.

The central metal triangle of the nickel analogue is equilateral with a mean Ni-Ni distance of 2.91(2) Å. On the other hand, both platinum and palladium trinuclear complex have non-equilateral triangles. The three Pd-Pd distances are 3.011(2) Å, 3.178(2) Å and 3.144(2) Å. The Pt-Pt distances are described earlier in this chapter. In both cases, one of the three distances are significantly shorter than the other two due to weak crystal packing forces. The triangle of platinum has higher symmetry than that of palladium. The average metal-sulfur distances of the nickel, palladium and platinum complexes are 2.15(6) Å, 2.33(2) Å and 2.37(3) Å, respectively. This trend as well as the metal-metal distances reflect the sizes of these metals. The M-S-M and S-M-S bond angles determine the shape of the M_2S_3 unit. Their mean values are very similar for all the nickel, palladium and platinum complexes: The M-S-M and S-M-S bond angles for nickel, palladium and platinum complexes are: 84.9(1.0)° and 77.4(1)°, 83.3(2)° and 79.2(3)°, 83.3(1)° and 79.3(1)°, respectively. The phosphorus atoms which protrude from the central M_3S_2 unit are situated above and below the plane of the M_3 triangle. The average S-M-P bond angles for nickel, palladium and platinum complexes are 90.0(1.9)°, 91.6(2)° and 89.8(1)°, respectively. They remain very similar to the square

planar angle. The S-M-S bond angles are sharpened in order to form a geometrically favourable M_3S_2 unit. This is compensated for by making P-M-P bond angles obtuse. The mean P-M-P bond angles of the nickel, palladium and platinum complexes are $98.0(1.6)^\circ$, $97.4(2)^\circ$ and $100(2)^\circ$, respectively.

One of the most interesting points of discussion about the M_3S_2 structure is the degree of the metal-metal interactions within the metal triangle. The three complexes mentioned above are believed to have no metal-metal bonds.^{20,21,19,40} The degrees of metal-metal interactions can, in principle, be estimated from the interatomic distances, provided those of structurally related compounds are compared. The remainder of this discussion involves whether the titled platinum complex has significant metal-metal interactions.

There are a number of complexes which have similar structural features to the title complex. The complex $[Ni_3S_2(C_5H_5)_3]$ has the average Ni-Ni distance of $2.81(5) \text{ \AA}$ ⁴¹, and believed to have weak metal-metal interactions. This distance is appreciably shorter than Ni-Ni distance of $[Ni_3S_2(PET_3)_6]^{2+}$. The cationic cobalt complex $[Co_3S_2(C_5H_5)_3]^+$ (10) has strong metal-metal interactions and three equivalent metal-metal bond distances are 2.452 \AA .⁴² The enneacarbonyl complex $[Fe_3(CO)_9S_2]$ (11) has a V-shaped metal frame rather than a metal triangle. The average Fe-Fe bond length is 2.60 \AA and the distance between the non-bonded iron atom is 3.37 \AA . The three iron atoms are bound by two triply bridging sulfur atoms with an equal distance of 2.23 \AA .

The methoxy bridged rhodium complex $[\text{Rh}_3(\text{diphos})_3(\text{OMe})_2]\text{PF}_6$ has

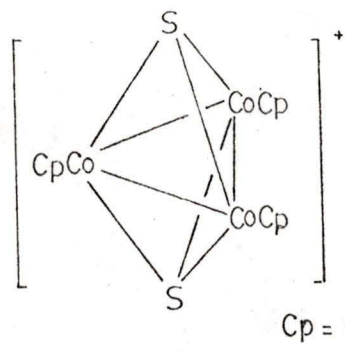

(10)

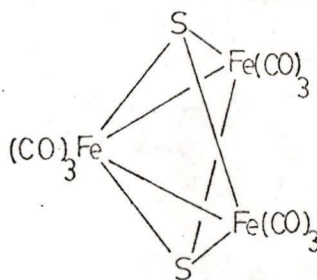

(11)

similar geometry; the Rh-Rh distance is 3.06 Å.⁴³ The shortest bonds of Pd₃S₂ and Pt₃S₂ are 3.01 Å and 3.11 Å, respectively, which lie within the same range as the Rh-Rh bond distance. There is little difference in the atomic sizes of the second and third transition series of the same group and of the neighbouring groups owing to the lanthanide contraction. The outer electrons are imperfectly shielded from the nuclear charge by the intermediately situated 4f electrons and the change in the number of outermost electrons contributes very little to the size of these atoms. The bond distances of d⁸ electron systems Rh(I) and Pt(II) in a similar structural environment can thus be expected to fall within the same range. However, metal-metal distances obtained in various dimeric platinum complexes containing formal metal-metal bonds are in the range 2.47 Å and 2.70 Å.^{44,45} and formal platinum-platinum bonds greater than 2.70 Å have not yet been reported.⁴⁶ Considering this evidence we have reached the conclusion

that there are some metal-metal interactions in Pt_3S_2 units but they are not strong enough to be considered formal metal-metal bonds. It might be interesting to see the correlation of this result with ^{195}Pt NMR data in the future when two-bond platinum-platinum coupling mechanisms are well understood; refer to Chapter II-B-2.

The PMe_2Ph groups have distorted tetrahedral geometries in order to place bulky phenyl groups away from the central Pt_3S_2 core. The average Pt-P-C(methyl) angle is 116.6° , and the average Pt-P-C(phenyl) angle 111.3° . They are significantly greater than the tetrahedral angle, thus causing the average C(methyl)-P-C(phenyl) angle and C(methyl)-P-C(methyl) angle to decrease to 103.9° and 102.6° , respectively. The phenyl ring plane numbered 4 in Table 9 is approximately parallel to the least squares coordination plane of the three platinum atoms. The phenyl ring planes 3 and 5 lie 64.2° and 69.3° from the plane of the metal triangle, respectively.

The tetramethyl borate has the average C-C distance of 1.541 Å. The C-B_{av} (1.658 Å) is longer because the covalent radius of boron (0.88 Å) is larger than that of carbon (0.77 Å). The boron is tetrahedral (the average C-B-C angle is 109.5°), but the ethyl carbon adjacent to the boron is distorted due to the steric crowding (the average C-C-B angle is 114.8°).

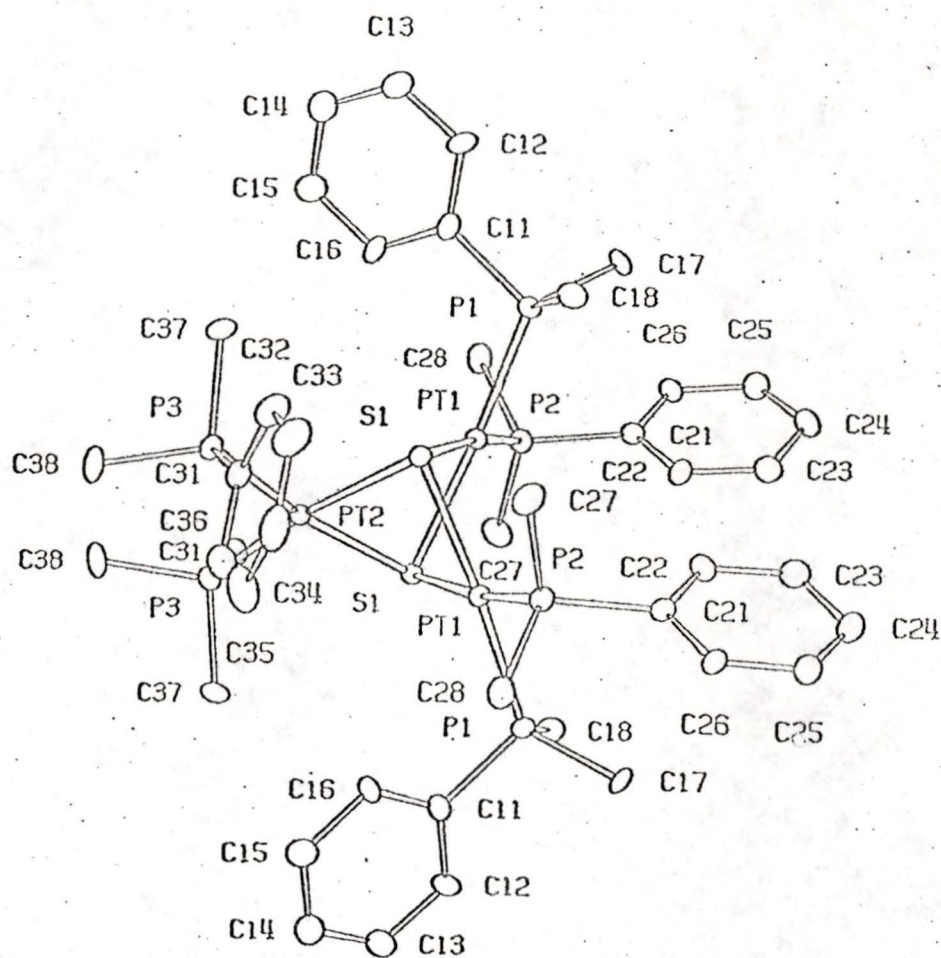

Figure 15. Molecular structure of $[\text{Pt}_3\text{S}_2(\text{PMe}_2\text{Ph})_6]^{2+}$.

Figure 16a. Schematic Molecular Structure Drawing of $[\text{Pt}_3\text{S}_2(\text{PMe}_2\text{Ph})_6]^{2+}$

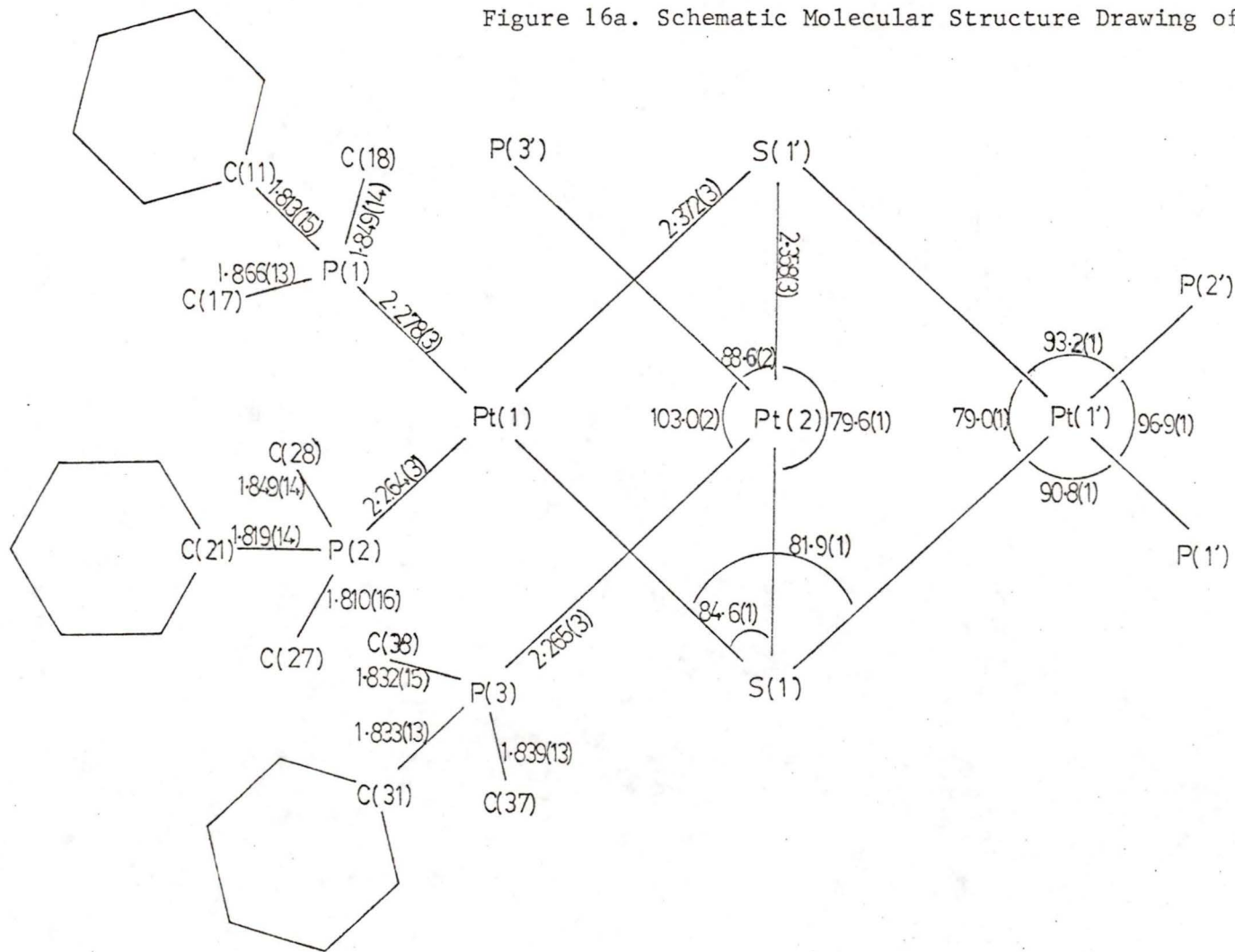
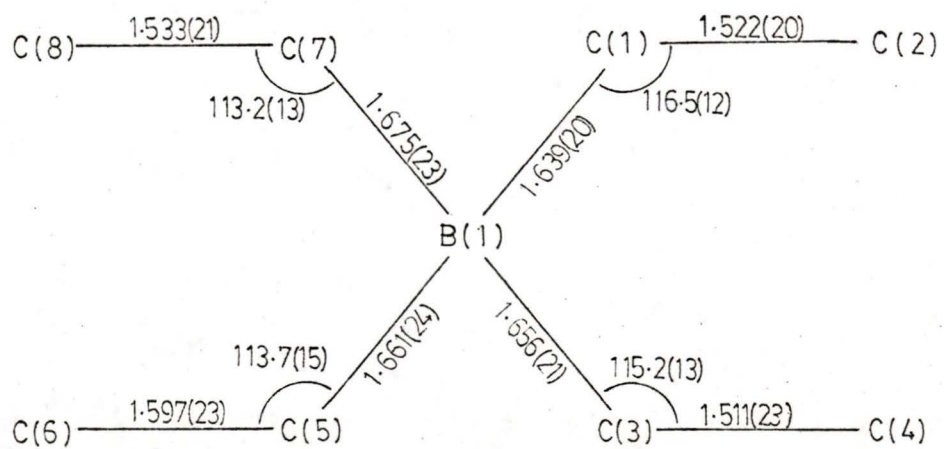

Figure 16b. Schematic Molecular Structure Drawing of BEt_4^- .



Interatomic distances (Å).

Atoms	Distance	Atoms	Distance
Pt(2) -Pt(1)	3.182(1)	Pt(1) -Pt(1)	3.108(1)
S(1) -Pt(1)	2.372(3)	S(1) -Pt(2)	2.358(3)
P(1) -Pt(1)	2.278(3)	P(3) -Pt(2)	2.265(3)
P(2) -Pt(1)	2.264(3)		
C(11) -P(1)	1.813(15)	C(21) -P(2)	1.819(14)
C(17) -P(1)	1.866(13)	C(27) -P(2)	1.810(16)
C(18) -P(1)	1.849(14)	C(28) -P(2)	1.849(14)
C(31) -P(3)	1.833(13)	C(38) -P(3)	1.832(15)
C(37) -P(3)	1.839(13)		
C(12) -C(11)	1.404(21)	C(14) -C(13)	1.400(24)
C(16) -C(11)	1.413(21)	C(15) -C(14)	1.406(25)
C(13) -C(12)	1.392(22)	C(16) -C(15)	1.437(21)
C(22) -C(21)	1.396(18)	C(24) -C(23)	1.488(24)
C(26) -C(21)	1.395(17)	C(25) -C(24)	1.363(23)
C(23) -C(22)	1.372(22)	C(26) -C(25)	1.362(21)
C(32) -C(31)	1.372(21)	C(34) -C(33)	1.397(29)
C(36) -C(31)	1.401(20)	C(35) -C(34)	1.334(31)
C(33) -C(32)	1.435(26)	C(36) -C(35)	1.415(22)
C(1) -B(1)	1.639(20)	C(5) -B(1)	1.661(24)
C(3) -B(1)	1.656(21)	C(7) -B(1)	1.675(23)
C(2) -C(1)	1.522(20)	C(6) -C(5)	1.597(23)
C(4) -C(3)	1.511(23)	C(8) -C(7)	1.533(21)

Estimated standard deviations are given in parentheses.

Bond angles ($^{\circ}$).

Atoms			Angle	Atoms			Angle
Pt(1)	-S(1)	-Pt(1)	81.9(1)	Pt(2)	-S(1)	-Pt(1)	84.6(1)
S(1)	-Pt(1)	-S(1)	79.0(1)	S(1)	-Pt(2)	-S(1)	79.6(1)
P(2)	-Pt(1)	-P(1)	96.9(1)	P(3)	-Pt(2)	-P(3)	103.0(2)
P(1)	-Pt(1)	-S(1)	90.8(1)	P(2)	-Pt(1)	-S(1)	172.2(1)
P(3)	-Pt(2)	-S(1)	168.2(1)	P(2)	-Pt(1)	-Pt(2)	126.8(1)
P(1)	-Pt(1)	-Pt(2)	124.2(1)	P(3)	-Pt(2)	-Pt(1)	122.0(1)
Pt(1)	-Pt(2)	-Pt(1)	58.5(0)	Pt(2)	-Pt(1)	-Pt(1')	60.75(0)
C(11)	-P(1)	-Pt(1)	112.1(6)	C(18)	-P(1)	-Pt(1)	113.7(5)
C(17)	-P(1)	-Pt(1)	120.7(5)	C(27)	-P(2)	-Pt(1)	116.2(5)
C(21)	-P(2)	-Pt(1)	111.2(4)	C(28)	-P(2)	-Pt(1)	113.8(6)
C(31)	-P(3)	-Pt(2)	110.5(4)	C(37)	-P(3)	-Pt(2)	112.1(5)
C(38)	-P(3)	-Pt(2)	123.3(5)	C(27)	-P(2)	-C(21)	103.2(7)
C(17)	-P(1)	-C(11)	103.8(7)	C(28)	-P(2)	-C(21)	106.9(6)
C(18)	-P(1)	-C(11)	104.2(7)	C(28)	-P(2)	-C(27)	104.6(8)
C(18)	-P(1)	-C(17)	100.5(7)	C(38)	-P(3)	-C(31)	100.8(6)
C(37)	-P(3)	-C(31)	105.5(7)	C(38)	-P(3)	-C(37)	102.8(7)
C(12)	-C(11)	-P(1)	120.8(13)	C(22)	-C(21)	-P(2)	116.8(10)
C(16)	-C(11)	-P(1)	116.9(12)	C(26)	-C(21)	-P(2)	121.5(11)
C(32)	-C(31)	-P(3)	121.2(12)	C(36)	-C(31)	-P(3)	116.0(12)
C(16)	-C(11)	-C(12)	122.2(14)	C(15)	-C(14)	-C(13)	119.7(18)
C(13)	-C(12)	-C(11)	116.8(16)	C(16)	-C(15)	-C(14)	118.5(18)
C(14)	-C(13)	-C(12)	123.5(17)	C(15)	-C(16)	-C(11)	119.3(16)
C(26)	-C(21)	-C(22)	121.7(14)	C(25)	-C(24)	-C(23)	119.2(17)
C(23)	-C(22)	-C(21)	119.5(15)	C(26)	-C(25)	-C(24)	121.5(16)
C(24)	-C(23)	-C(22)	118.3(16)	C(25)	-C(26)	-C(21)	119.8(14)
C(36)	-C(31)	-C(32)	122.8(13)	C(35)	-C(34)	-C(33)	121.8(20)
C(33)	-C(32)	-C(31)	116.9(18)	C(36)	-C(35)	-C(34)	120.2(23)
C(34)	-C(33)	-C(32)	119.9(20)	C(35)	-C(36)	-C(31)	118.3(19)
C(3)	-B(1)	-C(1)	111.2(12)	C(7)	-B(1)	-C(1)	109.5(12)
C(5)	-B(1)	-C(1)	106.2(13)	C(7)	-B(1)	-C(3)	107.6(13)
C(5)	-B(1)	-C(3)	108.3(12)	C(7)	-B(1)	-C(5)	114.1(13)
C(2)	-C(1)	-B(1)	116.5(12)	C(6)	-C(5)	-B(1)	113.7(15)
C(4)	-C(3)	-B(1)	115.2(13)	C(8)	-C(7)	-B(1)	113.2(13)

Estimated standard deviations are given in parentheses.

Table 9. Mean Planes for $[\text{Pt}_3\text{S}_2(\text{PMe}_2\text{Ph})_6](\text{BEt}_4)_2$

(a) Plane Definitions

Plane	Atoms	Description
1	Pt(1), S(1), S(1'), P(1), P(2)	Square plane of Pt(1)
2	Pt(2), S(1), S(1'), P(3), P(3')	Square plane of Pt(2)
3	C(11), C(12).....C(16)	Phenyl group attached to P(1)
4	C(21), C(22).....C(26)	Phenyl group attached to P(2)
5	C(31), C(32).....C(36)	Phenyl group attached to P(3)
6	Pt(1), Pt(1'), Pt(2)	Metal triangle

(b) Coefficients of Equations of Least-Squares Planes Through Selected Sets of Atoms: $Ax + By + Cz = D$ (Å)

Plane	A	B	C	D	χ^2 *
1	0.0603	0.8496	-0.5239	6.0712	49.5898
2	0.0841	-0.0000	-0.9965	-5.9734	351.7717
3	0.5111	-0.4827	-0.7112	-8.4480	0.9474
4	-0.9121	0.0742	-0.4033	-7.3540	1.7439
5	-0.3499	-0.9354	-0.0517	-9.1753	1.7328
6	-0.9947	0.0000	-0.1026	-7.5853	0.0577

* $\chi^2 = \sum_i (P_i^2 / \sigma^2(P_i))$ where P_i is the perpendicular distance of atom i from the plane.

(c) Perpendicular Distances of Atoms from the Planes

Plane	Atoms and Distances
1	Pt(1), 0.000(1); S(1), 0.010(3); S(1'), -0.010(3); P(1), -0.013(4); P(2), 0.013(4)
2	Pt(2), -0.000(0); S(1), -0.027(3); S(1'), 0.027(3); P(3), -0.030(3); P(3'), 0.030(3)
3	Pt(1), 0.502(1); Pt(1'), 2.864(1); Pt(2), 3.023(0); P(1), -0.069(3)
4	Pt(1), -1.247(1); Pt(1'), -0.291(1); Pt(2), -0.975(0); P(2), -0.006(4)
5	Pt(1), -4.540(1); Pt(1'), -4.492(1); Pt(2), -1.919(1); P(3), 0.026(3)
6	Pt(1), -0.000(1); Pt(1'), -0.000(1); Pt(2), -0.000(0)

Angles between normals to the planes: 1,2 = 58.19°; 1,3 = 90.38°; 1,4 = 77.33°; 1,6 = 90.36°; 2,5 = 88.73°; 2,6 = 88.94°; 3,4 = 102.43°; 3,5 = 71.97°; 3,6 = 115.81°; 4,5 = 74.30°; 4,6 = 18.45°; 5,6 = 69.31°

III-B. X-Ray Experimental

The technological aspect of X-ray crystallography is described explicitly in a book by Stout and Jensen.⁴⁷ A routine work used for this research is summarized below.

Crystals suitable for X-ray analyses were obtained by solute diffusion technique. A compound was dissolved in dichloromethane in a small tube. An equivolume of hexane or ethanol in which the substance is insoluble was placed very carefully on top of the CH_2Cl_2 solution to form a double layer. The solvents were allowed to mix by diffusion overnight. Crystals suitable for single-crystal X-ray diffraction studies were chosen using a polarizing microscope. Crystals had sizes between 0.3 mm and 0.8 mm, and all of these had well defined edges. They were bright under the microscope and extinguished completely at certain angles when they were rotated about an axis normal to the polarizing material. Crystals were used without shaping.

The space groups and cell constants of the crystals were determined by photographic techniques using a Weissenberg camera. Crystals were mounted either in capillaries or fastened on glass fibers by shellac in alcohol. It was mounted on the X-ray camera in such a way as to align the axis of rotation parallel to one of its well defined edges. A rotation photograph of the crystal was taken and the alignment of the rotation axis to one of the crystal axes was ensured. An aligned rotation photograph consists of straight layer lines which are perpendicular to the axis of rotation. In this photograph, two-dimensional

reciprocal lattice plane is condensed into a one-dimensional layer line. Each line is made up of the projection of reciprocal lattice points. The spacing of lines give the length of the unit cell along the rotational axis. This unit cell calculation was done using the formula (12),

$$r = \frac{n \lambda}{\sin \tan^{-1} (y_n / R)} \quad (12)$$

where r is the unit cell length, λ the wave-length (Copper K_α has $\lambda = 1.542 \text{ \AA}$), y_n the distance on the film from the zero to the n 'th layer lines and R the true film radius (57.3 mm). Other cell constants and the space group were obtained by the analyses of zero and first layer Weissenberg photographs. In the Weissenberg technique, a slotted screen was used to select just one layer line. As the crystal is rotated, the film is moved back and forth past the slot so as to record the reflections occurring at different times at different points on the film. The Weissenberg photograph is interpreted as a distorted photograph of a reciprocal lattice section. Two axes on the photograph appear as straight lines. Indexing of the reciprocal lattice lines was done by comparing the zero and first layer photographs. The camera is constructed so that 1 mm of film translation is equal to 2° . The diffraction angle θ was obtained from the distance between two spots on the axis which are equally separated from the center line. Two unit cell lengths which were not obtained by a rotational photograph were calculated from the values θ using the equation (13). The separation between the two axes on the photograph gave the angle between the two.

$$d = \frac{n\lambda}{2 \sin\theta} \quad (13)$$

Zero and first order precession photographs were taken to provide an undistorted picture of the reciprocal lattice cell. In this technique, a film is allowed to precess as the crystal precesses so as to keep the plane of film always parallel to the reciprocal lattice plane.

Both Weissenberg and precession photographs were used to determine the space group. Careful comparison between the zero and first order photographs provided information about the systematic absences. This is more clearly seen in the precession photographs but a wider range of the reciprocal lattice is covered by Weissenberg photographs. The systematic absences indicate when the structure has symmetry elements involving translation such as glide planes and screw axes. One or more possible space groups were assigned according to the diffraction symbol.

The density of crystals was obtained by a flotation technique. Crystals were suspended in a mixture of liquids of known densities. The weight of the liquid mixture was weighed in an accurately calibrated bottle. The density of the liquid which is same as that of the crystals was calculated from the equation $\rho = M / V$. The mass of the unit cell was then obtained from the density, and the volume of the unit cell calculated from the cell constants. The formula, $M = \rho N_A V_{\text{cell}}$ was used. The mass per asymmetric unit was calculated by dividing M by the number of asymmetric units given for the space group. This value was compared to the theoretically obtained molecular weight of

the compound. The density was also used for the calculation of the linear absorption coefficient, which is the measure of absorption of X-rays by the crystal. The linear absorption coefficient for radiation of specified wave length λ , μ_λ is calculated using the formula(14),

$$\mu_\lambda = \rho \sum \left(\frac{P_n}{100} \right) \left(\frac{\mu}{\rho} \right)_{\lambda, E_n} \quad (14)$$

where ρ is the density of the crystal and P_n the percentage of element E_n in the molecule. Absorption produces errors in X-ray data. This reduces the total diffracted intensity and drifts the center of a record so that 2θ appears slightly larger than the actual size.

The unit cell was determined by studying the geometrical features of the diffraction by the crystal as has been summarized above. The arrangement of atoms in the cell was determined from the intensities of the diffraction maxima. The intensity data were collected with Zr-filtered Mo- K_α radiation ($\lambda = 0.71069 \text{ \AA}$) on a PDP-11 computer controlled Picker four-circle diffractometer. The intensities were measured by the direct counting of the diffracted photons. The diffractometer provides us with more accurate intensity data than does the film method. The four-circle diffractometer has arcs ϕ (ϕ), χ (χ), ω (ω) and two θ (2θ), which are used to adjust the orientation of crystal. The χ and ϕ arcs were adjusted to bring desired reciprocal lattice points into the equatorial plane within the sphere of reflection defined by the source, crystal and detector. A $\theta/2\theta$ scan method was used to obtain desired intensity information. The crystal was rotated at a speed which is slow enough that a reasonable number of quanta were

diffracted and detected. During the rotation, the reciprocal lattice point was carried from the outside to the inside of the sphere of reflection. The scan was carried out with a number of steps of 0.01° in 2θ counting for 0.25 sec per step. The peak counts were obtained by subtracting the background from the scan counts.

The conventional crystallographic calculations were performed using the computer program SHELX-76 which uses scattering factors from International Tables for X-ray Crystallography.⁴⁸ Raw intensity data were converted to observed structure amplitudes by data reduction and numerical absorption corrections were performed. Systematic absences were rejected and equivalent reflections were averaged out. The crystal structure was solved by the heavy-atom method. The first step in the structure solution was based on the determination of the positions of platinum atoms. These positions were compared and agreed with the major peaks in the Patterson synthesis. A three-dimensional Fourier synthesis computed with the phases of the platinum atoms gave the positions of phosphorus and sulfur atoms. Several cycles of full-matrix least-squares refinement led to smaller values of the residual index R:

$$R = \frac{\sum ||F_o| - |F_c||}{\sum |F_o|},$$

where $|F_o|$ and $|F_c|$ are observed and calculated structure factor amplitudes. The function minimised was

$$\sum w(|F_o| - |F_c|)^2,$$

where $w = 1 / (\sigma^2(F_o) + 0.001F_o^2)$. Subsequent structure factor calculations and Fourier synthesis revealed the positions of the remaining non-hydrogen atoms. Each atom was refined with an individual isotropic thermal parameter. Some atoms were later refined anisotropically. No hydrogen atoms were located. Several cycles of refinement was performed until small and consistent R values were obtained.

III-B-1. X-Ray Experimental of $[\text{Pt}_2\text{Cl}_2(\mu\text{-Cl})(\mu\text{-SPh})(\text{PEt}_3)_2]$

Crystals were obtained from dichloromethane solution of the title complex. The crystals were mounted in capillaries. Preliminary photographic data showed that the crystal belong to the orthorhombic system with systematic extinctions consistent with the space group Pbca-D_{2h}^{15} (No. 61). Unit cell dimensions at $23 \pm 2^\circ\text{C}$ are $a = 23.389(5) \text{ \AA}$, $b = 28.351(7) \text{ \AA}$, $c = 8.154(2) \text{ \AA}$, $\alpha = \beta = \gamma = 90^\circ$, $V_{\text{cell}} = 5407(2) \text{ \AA}^3$ and $Z = 8$; $\rho_{\text{calc}} = 2.068 \text{ g/cm}^3$ for $\text{C}_{18}\text{H}_{35}\text{Cl}_3\text{P}_2\text{Pt}_2\text{S}$ and $\rho_{\text{obs}} = 2.060 \text{ g/cm}^3$ (flotation in $\text{CCl}_4/\text{CHBr}_3$); $M = 842.021$. The crystal was mounted along c -axis. The intensities of 2590 reflections were measured with Mo-K_α radiation. An absorption correction was applied to this data ($\mu = 104.04 \text{ cm}^{-1}$, crystal volume 0.0064 mm^3 , transmission factors 0.11-0.58).

Two platinum atoms were located from a Patterson synthesis. A three dimensional Fourier synthesis computed with the phases of the platinum atoms gave the positions of phosphorus and sulfur atoms. Platinum, phosphorus and sulfur atoms were treated anisotropically. The final refinement converged to values of R and R_w of 0.0915 and 0.0833, respectively. The final values of the positional and temperature parameters are given in Table 10 and anisotropic temperature parameters in Table 11. Selected intermolecular distances are listed in Table 12.

Fractional atomic coordinates and temperature parameters.

Atom	x/a	y/b	z/c	U_{eq}
Pt(1)	10384(6)	12030(5)	33820(15)	669(6)
Pt(2)	23868(6)	14320(4)	21362(13)	472(5)
Cl(1)	597(6)	1255(5)	5903(12)	152(7)
Cl(2)	3215(4)	1617(3)	3591(10)	76(3)
Cl(3)	1968(4)	1168(3)	4682(8)	73(3)
P(1)	181(5)	1211(5)	2221(11)	101(5)
P(2)	2722(4)	1638(3)	-294(9)	60(3)
S(1)	1532(3)	1230(3)	980(8)	46(3)
C(1)	163(1)	65(1)	25(3)	43(7)'
C(2)	149(2)	57(1)	-138(4)	70(9)'
C(3)	157(2)	13(1)	-213(4)	77(10)'
C(4)	183(2)	-23(1)	-115(4)	86(11)'
C(5)	194(2)	-16(1)	52(4)	81(10)'
C(6)	188(2)	30(1)	123(4)	72(9)'
C(11)	20(2)	114(1)	3(6)	124(16)'
C(12)	-38(3)	108(2)	-75(8)	173(22)'
C(13)	-19(2)	182(2)	279(6)	130(16)'
C(14)	14(3)	221(3)	207(8)	221(30)'
C(15)	-27(2)	74(2)	299(6)	138(17)'
C(16)	0(3)	25(2)	264(8)	196(26)'

C(21)	336(2)	204(1)	-19(4)	83(10)'
C(22)	369(2)	209(1)	-180(4)	90(11)'
C(23)	223(2)	193(1)	-168(4)	76(10)'
C(24)	192(2)	238(1)	-81(4)	91(11)'
C(25)	296(2)	113(1)	-150(4)	67(9)'
C(26)	339(2)	83(1)	-61(4)	82(10)'

Estimated standard deviations are given in parentheses.

Coordinates $\times 10^n$ where $n = 5, 4, 4, 4, 3$ for Pt, Cl, S, P, C.

Temperature parameters $\times 10^n$ where $n = 4$ for Pt and 3 otherwise.

U_{eq} = the equivalent isotropic temperature parameter.

$$U_{eq} = 1/3 \sum_i \sum_j U_{ij} a_i^* a_j^* (a_i \cdot a_j)$$

Primed values indicate that U_{iso} is given.

$$T = \exp(-8\pi^2 U_{iso} \sin^2 \theta / \lambda^2)$$

Anisotropic temperature parameters (\AA^2).

Atom	U_{11}	U_{22}	U_{33}	U_{23}	U_{13}	U_{12}
Pt(1)	502(10)	1133(12)	373(8)	55(7)	38(7)	222(8)
Pt(2)	507(10)	542(8)	367(8)	-14(5)	-34(6)	31(6)
Cl(1)	103(11)	308(17)	45(6)	23(7)	19(7)	71(11)
Cl(2)	70(7)	93(6)	66(5)	-5(4)	-18(5)	-11(5)
Cl(3)	76(7)	110(6)	33(4)	8(4)	0(5)	13(5)
P(1)	63(8)	194(11)	45(6)	4(6)	-4(6)	29(7)
P(2)	78(8)	65(5)	36(5)	2(4)	3(5)	-2(5)
S(1)	37(5)	64(4)	38(4)	-7(3)	0(4)	3(4)

Estimated standard deviations are given in parentheses.

U values $\times 10^n$ where $n=4$ for Pt and $n=3$ otherwise.

$$T = \exp -2\pi^2 (U_{11} h^2 a^{*2} + \dots + 2U_{23} k l b^* c^* + \dots)$$

Selected intermolecular distances (Å).

Atoms	Distance	Sym	Tx	Ty	Tz
C(24) ...Pt(2)	3.919	-3	0	1	0
C(4) ...Pt(2)	4.121	4	0	0	-1
C(2) ...Cl(1)	3.613	1	0	0	-1
C(11) ...Cl(1)	3.506	1	0	0	-1
C(12) ...Cl(1)	3.596	1	0	0	-1
C(21) ...Cl(2)	3.940	-3	0	1	0
C(22) ...Cl(2)	3.840	-3	0	1	0
C(4) ...Cl(2)	3.945	4	0	0	-1
C(12) ...Cl(2)	4.019	-4	0	0	1
C(13) ...Cl(2)	3.931	-4	0	0	1
C(2) ...Cl(3)	3.796	1	0	0	-1
C(3) ...Cl(3)	4.044	1	0	0	-1
C(23) ...Cl(3)	3.715	1	0	0	-1
C(25) ...Cl(3)	3.885	1	0	0	-1
C(4) ...Cl(3)	3.933	4	0	0	-1
C(5) ...Cl(3)	3.900	4	0	0	-1
C(25) ...C(5)	3.695	4	0	0	-1

The symmetry positions are for the second atom.

They are defined: 1 = x,y,z; 2 = 1/2 + x, 1/2 - y, -z;

3 = -x, 1/2 + y, 1/2 - z; 4 = 1/2 - x, -y, 1/2 + z.

A negative symmetry position denotes inversion.

The translations (T) are applied finally.

III-B-2. X-Ray Experimental of $[\text{Pt}_3\text{S}_2(\text{PMe}_2\text{Ph})_6](\text{BET}_4)_2$

Suitable crystals of the title complex were obtained from $\text{CH}_2\text{Cl}_2/\text{EtOH}$. Capillaries were used to mount the crystal. The crystal was assumed to belong triclinic system from the preliminary photographic analysis and the intensity data were collected on this assumption. More accurate measurement of the cell dimensions from the diffractometer revealed that the crystal was in fact monoclinic space group $\text{C}2/c-\text{C}_{2h}^6$ (No. 15). The indices were converted to the monoclinic system using the Niggli matrix. The cell parameters were: $a = 15.447(2)$ Å, $b = 18.033(3)$ Å, $c = 26.505(5)$ Å, $\alpha = \gamma = 90^\circ$ and $\beta = 96.73(2)^\circ$. Other crystal data at temperature 23°C were as follows: $V_{\text{cell}} = 7332(2)$ Å³; $\rho_{\text{calc}} = 1.569$ g/cm³ for $\text{C}_{64}\text{H}_{106}\text{B}_2\text{P}_6\text{Pt}_3\text{S}_2$; $\rho_{\text{obs}} = 1.568$ g/cm³ (flotation in $\text{CCl}_4/m\text{-xylene}$); $M = 1732.393$. The asymmetric unit was a half molecule. The intensities of 7289 reflections were measured and an absorption correction was applied ($\mu = 62.22$ cm⁻¹, crystal dimensions $0.37 \times 0.46 \times 0.38$ mm, transmission factors 0.048-0.160).

One platinum atom was located and the first cycle of full-matrix least squares refinement yielded $R = 0.580$, and gave the positions of another platinum and phosphorus atoms. Several cycles of refinement by means of the program SHELX led to a final R and R_w values of 0.0545 and 0.0536, respectively. The fractional atomic coordinates and temperature parameters are listed in Table 13, and anisotropic temperature parameters in Table 14. Selected intermolecular distances are given in Table 15.

Fractional atomic coordinates and temperature parameters.

Atom	x/a	y/b	z/c	U_{eq}
Pt(1)	50149(3)	64742(3)	30872(2)	524(2)
Pt(2)	50000(0)	49346(4)	25000(0)	488(3)
S(1)	5983(2)	5939(2)	2558(1)	51(1)
P(1)	6158(2)	6894(2)	3633(1)	62(1)
P(2)	3944(2)	6935(2)	3511(1)	64(1)
P(3)	3846(2)	4152(2)	2455(1)	62(1)
C(11)	6598(11)	6180(8)	4072(5)	77(6)
C(12)	7415(10)	6269(9)	4359(6)	87(7)
C(13)	7685(12)	5706(11)	4701(6)	105(8)
C(14)	7184(15)	5076(11)	4772(7)	111(9)
C(15)	6357(14)	4995(10)	4493(7)	109(9)
C(16)	6058(11)	5561(8)	4133(5)	87(7)
C(17)	6031(9)	7711(7)	4049(5)	79(6)
C(18)	7102(9)	7195(9)	3314(5)	89(6)
C(21)	4004(8)	7941(7)	3554(5)	64(5)
C(22)	4283(9)	8315(9)	3142(6)	79(6)
C(23)	4339(10)	9074(11)	3152(7)	101(8)
C(24)	4117(11)	9470(10)	3612(9)	112(9)
C(25)	3872(13)	9069(10)	4008(6)	99(8)
C(26)	3811(10)	8317(8)	3987(5)	78(6)
C(27)	2837(9)	6771(9)	3226(6)	98(7)
C(28)	3969(12)	6580(8)	4167(5)	97(7)

TABLE 13 (continued).

C(31)	3137(10)	4387(8)	2939(5)	71(6)
C(32)	2311(11)	4656(11)	2807(6)	102(8)
C(33)	1800(13)	4807(13)	3214(11)	144(12)
C(34)	2153(18)	4682(12)	3717(10)	132(12)
C(35)	2968(18)	4439(11)	3834(8)	145(12)
C(36)	3485(12)	4261(9)	3444(6)	104(8)
C(37)	3153(10)	4223(9)	1844(5)	85(6)
C(38)	3955(10)	3148(8)	2548(6)	95(7)
B(1)	4694(12)	2032(9)	812(5)	74(7)
C(1)	5229(11)	2309(9)	347(5)	92(7)
C(2)	5782(12)	3004(10)	444(6)	117(8)
C(3)	4092(10)	2711(8)	1007(6)	90(7)
C(4)	3379(12)	2994(10)	615(7)	116(8)
C(5)	5442(12)	1802(11)	1288(6)	113(8)
C(6)	5048(14)	1432(10)	1758(6)	121(10)
C(7)	4021(11)	1338(8)	608(6)	91(7)
C(8)	4500(11)	654(9)	437(6)	106(8)

Estimated standard deviations are given in parentheses.

Coordinates $\times 10^n$ where $n = 5, 4, 4, 4, 4$ for Pt, S, P, C and B.

Temperature parameters $\times 10^n$ where $n = 4, 3, 3, 3, 3$ for Pt, S, P, C, and B.

U_{eq} = the equivalent isotropic temperature parameter.

$$U_{eq} = 1/3 \sum_i \sum_j U_{ij} a_i a_j (a_i \cdot a_j)$$

$$T = \exp(-8\pi^2 U_{iso} \sin^2 \theta / \lambda^2)$$

TABLE 14

Anisotropic temperature parameters (\AA^2).

Atom	U_{11}	U_{22}	U_{33}	U_{23}	U_{13}	U_{12}
Pt(1)	583(4)	566(4)	438(4)	-33(2)	122(3)	-7(2)
Pt(2)	548(5)	519(5)	416(4)	0(0)	134(3)	0(0)
S(1)	45(2)	59(2)	51(2)	3(1)	10(1)	3(1)
P(1)	66(2)	70(2)	51(2)	-5(2)	7(2)	-8(2)
P(2)	71(2)	70(3)	55(2)	-8(2)	22(2)	1(2)
P(3)	67(2)	63(2)	59(2)	-10(2)	21(2)	-10(2)
C(11)	106(13)	67(10)	61(9)	1(8)	23(9)	23(9)
C(12)	75(11)	107(13)	74(10)	-2(10)	-13(9)	33(9)
C(13)	102(14)	115(16)	97(13)	-7(12)	1(10)	41(12)
C(14)	147(19)	101(16)	88(13)	-12(11)	24(13)	20(13)
C(15)	125(16)	124(16)	78(12)	-5(11)	12(11)	7(12)
C(16)	148(15)	60(10)	55(9)	13(8)	18(9)	29(10)
C(17)	91(10)	58(9)	85(10)	-36(8)	0(8)	-11(7)
C(18)	71(10)	110(13)	85(10)	6(9)	8(8)	-30(9)
C(21)	65(9)	73(9)	55(8)	-9(8)	11(7)	2(7)
C(22)	74(10)	69(11)	94(11)	19(9)	8(8)	1(8)
C(23)	75(11)	100(15)	124(15)	6(12)	-8(10)	-16(10)
C(24)	96(13)	78(13)	154(18)	-22(14)	-19(12)	-8(10)
C(25)	144(16)	84(14)	72(11)	-5(10)	20(10)	5(11)
C(26)	94(11)	67(11)	72(10)	-19(8)	0(8)	0(8)
C(27)	61(10)	119(13)	117(13)	-31(10)	32(9)	-13(9)
C(28)	156(16)	79(11)	63(10)	8(8)	48(10)	-17(10)

TABLE 14 (continued).

C(31)	73(11)	70(10)	75(11)	-5(8)	37(8)	-15(8)
C(32)	65(11)	133(15)	116(13)	-39(11)	45(10)	-16(10)
C(33)	98(15)	164(22)	174(23)	-53(19)	38(17)	-11(13)
C(34)	153(22)	97(15)	166(22)	-27(15)	104(20)	-27(15)
C(35)	202(25)	109(16)	146(19)	15(13)	117(19)	45(16)
C(36)	138(15)	101(13)	81(12)	15(10)	49(12)	3(11)
C(37)	86(10)	111(12)	54(9)	-17(8)	-4(7)	-10(9)
C(38)	120(13)	48(9)	129(13)	-8(9)	62(11)	-17(8)
B(1)	104(13)	71(12)	49(9)	7(8)	15(9)	10(10)
C(1)	116(13)	100(12)	66(10)	-4(8)	30(9)	-14(10)
C(2)	149(16)	98(13)	112(13)	-19(11)	46(12)	-52(12)
C(3)	91(11)	86(11)	95(11)	-2(9)	22(9)	30(9)
C(4)	111(14)	100(14)	136(15)	-3(12)	13(12)	17(11)
C(5)	145(16)	139(16)	57(10)	-4(10)	16(10)	14(12)
C(6)	191(21)	119(16)	54(10)	11(9)	20(11)	-12(13)
C(7)	102(12)	62(10)	111(13)	-14(9)	20(10)	-5(8)
C(8)	130(15)	72(12)	116(14)	-12(10)	15(11)	-11(10)

Estimated standard deviations are given in parentheses.

U values $\times 10^n$ where $n=4,3,3,3,3$ for Pt,S,P,C, and B.

$$T = \exp -2\pi^2 (U_{11} h^2 a^{*2} + \dots + 2U_{23} k l b^* c^* + \dots)$$

Selected intermolecular distances (\AA).

Atoms	Distance	Sym	Tx	Ty	Tz
Pt(2) ...Pt(1)	3.182	2	1	0	0
S(1) ...Pt(1)	2.370	2	1	0	0
S(1) ...S(1)	3.017	2	1	0	0
P(2) ...S(1)	3.368	2	1	0	0
P(3) ...S(1)	3.234	2	1	0	0
C(27) ...S(1)	3.282	2	1	0	0
C(31) ...S(1)	3.441	2	1	0	0
C(32) ...S(1)	3.720	2	1	0	0
C(37) ...S(1)	3.658	2	1	0	0
P(3) ...P(3)	3.545	2	1	0	0
C(38) ...P(3)	3.849	2	1	0	0
C(35) ...C(2)	3.636	2	1	0	0
C(15) ...C(4)	3.646	2	1	0	0
C(32) ...C(23)	3.541	2	1	-1	0
C(37) ...C(24)	3.601	2	1	-1	0
C(37) ...C(25)	3.647	2	1	-1	0
C(38) ...C(38)	3.267	2	1	0	0

The symmetry positions are for the second atom.

They are defined:

A negative symmetry position denotes inversion.

The translations (T) are applied finally.

III-B-3. X-Ray Experimental of [(dppe)PtS₄]

Thin needle crystals of the tetrasulfide complex were obtained from CH₂Cl₂/hexane. The crystal was mounted on glass fibre by shellac in alcohol. Systematic extinctions observed in photographic data indicated the presence of glide planes along c and along a axes. This is consistent with the space group Pbc₂a - D_{2h}¹⁵ (No. 61). The cell parameters are: a = 15.238(8) Å, b = 18.463(8) Å, c = 19.868(12) Å, α = β = γ = 90°. Other unit cell dimensions are V_{cell} = 5589.52(7) Å³ and Z = 8; ρ_{calc} = 1.7148 g/cm³ for C₂₆H₂₄P₂PtS₄ and ρ_{obs} = 1.7526 g/cm³ (flotation in CCl₄/CHBr₃); M = 721.753. The intensities of 3427 reflections were measured.

One platinum atom was located from a Patterson synthesis. The first structure factor calculation and Fourier synthesis by means of SHELX gave R = 0.766. The positions of two sulfur and two phosphorus atoms coordinated to the platinum in a square planar fashion were obtained. Subsequent calculations lead to the minimum R value of 0.24, but it failed to locate all the four sulfur atoms. Another attempt to solve the structure was made using the computer program MULTAN-78, but it also failed.

After the completion of this work, the first crystal structure of a compound with a PtS₄ ring, [Pt(PPh₃)₂S₄]·CHCl₃ was reported by Dudis and Fackler.²⁷

EPILOGUE

The chemistry of platinum-sulfur complexes offers an extensive scope for research. Three structurally interesting complexes were investigated in this research work using two powerful techniques: X-ray crystallography and nuclear magnetic resonance spectroscopy. The correlation of X-ray data with NMR data is of great theoretical interest. It is recognized that metal-ligand σ bonding is related to coupling constants through the s orbital contributions to the bonding. X-ray crystallography currently gives accurate bond lengths. Electron density maps are obtained also and there is a promising future for the precise determination of electron cloud distributions. Accumulation of X-ray and NMR data enables us to approach a thorough understanding of the relationship between these techniques. The metal-metal interactions in polynuclear complexes present a particularly challenging aspect of this type of work, the understanding of which will provide information on the extent of metal-metal interactions at interatomic distances on the borderline between bonding and non-bonding.

The platinum-sulfur complexes might become of practical importance, in that polynuclear platinum-sulfur complexes are interesting models for homogeneous catalysis. The ultimate aim is to prepare complexes which undergo redox reactions without changing their chemical composition. The three metal and two triply bridging ligand units arranged in

a trigonal bipyramidal fashion possesses a structural stability which might be useful in this way. A complex containing such a structural feature seems a reasonable system for future catalytic research.

REFERENCES

- (1) T. E. Wolff, P. P. Power, R. B. Frankel and R. H. Holm, *J. Am. Chem. Soc.*, 102, 4694 (1980).
- (2) D. Coucouvanis, E. D. Simbon and N. C. Baenzler, *J. Am. Chem. Soc.*, 102, 6644 (1980).
- (3) R. H. Tickelman et. al., *J. Am. Chem. Soc.*, 102, 5550 (1980).
- (4) F. E. Massoth, *Adv. Cat.*, 27, 265 (1978).
- (5) S. C. Schuman, H. Shalit, *Cat. Rev.*, 4, 245 (1970).
- (6) H. Kwart, G. C. A. Schuit and B. C. Gates, *J. Cat.*, 61, 128 (1980).
- (7) M. Rakowski DuBois, M. C. VanDerveer, D. L. DuBois, R. C. Haltiwanger and W. K. Miller, *J. Am. Chem. Soc.*, 102, 7456 (1980).
- (8) J. Chatt and N. R. Davies, *Quart. Rev.*, 12, 265 (1958).
- (9) J. A. Davis and F. R. Hartley, *Chem. Rev.*, 81, 79 (1981).
- (10) S. E. Livingstone, *Quart. Rev. Chem. Soc.*, 19, 386 (1965).
- (11) F. R. Hartley, "The Chemistry of Platinum and Palladium", Applied Science Publishers Ltd., London, 1973.
- (12) Review of thioether complexes was presented by S. G. Murray and F. R. Hartley, *Chem. Rev.*, 81, 365 (1981); references to the reviews on chalcogen-containing ligands are found therein.
- (13) J. Chatt and F. G. Mann, *J. Chem. Soc.*, 1949 (1938).
- (14) J. Chatt and F. A. Hart, *J. Chem. Soc.*, 2363 (1953).
- (15) J. Chatt and J. M. Davidson, *J. Chem. Soc.*, 2433 (1964).

- (16) J. Chatt and J. M. Davidson, *J. Chem. Soc.*, 2433 (1964).
- (17) C. Eaborn, K. J. Odell and A. Pidcock, *J. Organometal. Chem.*, 170, 105 (1979).
- (18) A. J. Carty, Personal communication with K. R. Dixon.
- (19) J. Chatt and D. M. P. Mingos, *J. Chem. Soc. (A)*, 1243 (1970).
- (20) H. Werner and W. Bertleff, *Inorg., Chim. Acta*, 43, 199 (1980).
- (21) C. A. Ghilardi, S. Midollini and L. Sacconi, *Inorg. Chim. Acta*, 31, L431 (1978).
- (22) M. Schmidt and G. G. Hoffmann, *Z. Naturforsch. B*, 34B, 451 (1979).
- (23) (a) H. Schiff, *Justus Liebigs, Ann. Chem.*, 115, 68 (1860).
(b) The synthesis of $(\text{NH}_4)_2[\text{Pt}(\text{S}_5)_3]$ is described by K. A. Hofmann and F. Höchtlen, *Chem. Ber.*, 36, 3090 (1903).
(c) X-ray crystal structure of $(\text{NH}_4)_2[\text{Pt}(\text{S}_5)_3] \cdot 2\text{H}_2\text{O}$ appears in a paper by P. E. Jones and L. Katz, *Acta. Crystallogr.*, B25, 745 (1969).
(d) Preparations of bis and tris(pentasulfido)platinate are described in a paper by A. E. Wickenden and T. A. Krause, *Inorg. Chem.*, 8, 779 (1969).
- (24) R. Ugo, G. LaMonica, S. Cenini, A. Segre and F. Conti, *J. Chem. Soc. (A)*, 522 (1971).
- (25) B. Kreutzer, P. Kreutzer and W. Beck, *Z. Naturforsch.*, 27B, 461 (1972).
- (26) R. A. Krause, *Inorg. Nucl. Chem. Lett.*, 7, 973 (1971).
- (27) D. Dudis and J. P. Fackler Jr., *Inorg. Chem.*, 21, 3577 (1982).

- (28) R. J. Abraham, "Analysis of High Resolution NMR Spectra", Elsevir, Amsterdam, 1971.
- (29) P. S. Pregosin and R. W. Kuntz, "NMR Basic Principles and Progress", Spinger-Verlag, Heiderberg, 1979, vol. 16.
- (30) K. R. Dixon and J. B. Brandon, Can J Chem. 59, 1188 (1981).
- (31) K. B. Wiberg and B. J. Nist, "Interpretation of NMR Spectra", W. A. Benjamin, Inc., New York, 1962, Chapt. 5, No.5-102.
- (32) P. S. Pregosin, Coord. Chem. Rev., 44, 247 (1982).
- (33) K. J. Odell, Ph. D. Thesis, University of Sussex, England, 1976.
- (34) R. K. Harris, Educ. in Chem. 14, 44 (1977).
- (35) R. Goldsberry and K. Cohn, Inorg. Syn., Vol. XIII, 26.
- (36) V. D. Bianco and S. Doronzo, Inorg. Syn., Vol. XVI, 161.
- (37) G. W. Bushnell, Unpublished work.
- (38) D. L. Sales, J. Stokes and P. Woodward, J. Chem. Soc.(A), 1852 (1968).
- (39) P. H. Bird, U. Siriwardane, R. D. Lai and A. Shaver, Can. J. Chem., 60, 2075 (1982).
- (40) H. Vahrenkamp, Angew. Chem. Internat. Edit., 14, 322 (1975).
- (41) H. Vahrenkamp, V. A. Uchtman and L. F. Dahl, J. Am. Chem. Soc., 90, 3272 (1968).
- (42) F. D. Frisch and L. F. Dahl, J. Am. Chem. Soc., 94, 5082 (1972).
- (43) J. Halpern, D. P. Riley, A. C. S. Chan and J. J. Pluth, J. Am. Chem. Soc., 8055 (1977).
- (44) H. B. Gray, J. Am. Chem. Soc., 104 4253 (1982).

- (45) A. Moor, P. S. Pregosin and L. M. Venanzi, *Inorg. Chim. Acta*, 48, 153 (1981).
- (46) F. A. Cotton and G. Wilkinson, "Advanced Inorganic Chemistry", John Wiley & Sons, Inc., 1980.
- (47) G. H. Stout and L. H. Jensen, "X-Ray Structure Determination", The Macmillan Company, New York, 1968.
- (48) C. H. Macgillavry and G. D. Rieck, eds., "International Tables for X-Ray Crystallography", Kynoch Press, Birmingham, England, 1960.
- (49) W. A. Spofford, E. L. Amma and C. V. Senoff, *Inorg. Chem.*, 10, 2309 (1971).

APPENDIX I

Observed and Calculated Structure Factors for $\text{cis-}[\text{Pt}_2\text{Cl}_3(\text{SPh})(\text{PEt}_3)_2]$

OBSERVED AND CALCULATED STRUCTURE FACTORS FOR CIS-((MU-CL).(MU-SPH)(PTCLPET3)2)

H	K	L	FO	FC	H	K	L	FO	FC	H	K	L	FO	FC	H	K	L	FO	FC	H	K	L	FO	FC
3	17	1	43	30	4	3	0	134	-122	4	9	3	117	123	4	16	5	38	-43	7	5	3	324	310
3	17	2	50	-40	4	4	2	95	-101	4	9	4	107	113	4	16	6	87	-75	7	5	3	385	-71
3	17	3	86	-75	4	4	3	28	23	4	9	5	58	69	4	16	7	86	94	7	5	4	331	-40
3	17	4	85	83	4	4	4	178	166	4	9	6	64	61	4	16	8	149	-145	7	5	5	66	40
3	17	5	21	22	4	4	5	215	-209	4	9	7	53	67	4	16	9	78	77	7	5	6	150	137
3	18	1	30	18	4	4	6	81	-78	4	4	0	489	-447	4	16	10	55	54	7	5	7	150	-122
3	18	2	55	-53	4	4	7	57	45	4	10	1	58	64	4	16	11	98	22	7	5	8	142	112
3	18	3	73	64	4	4	8	143	-134	4	10	2	317	325	4	16	12	22	78	7	5	9	142	88
3	18	4	65	-60	4	4	9	225	216	4	10	3	206	206	4	16	13	46	22	7	5	10	33	33
3	18	5	55	59	4	4	10	204	203	4	10	4	157	-162	4	16	14	30	22	7	5	11	33	33
3	19	1	34	-41	4	4	11	171	-168	4	10	5	260	-267	4	16	15	63	50	7	5	12	33	15
3	19	2	80	70	4	4	12	481	500	4	10	6	33	8	4	16	16	68	61	7	5	13	33	15
3	19	3	14	3	4	4	13	224	234	4	10	7	68	53	4	16	17	148	137	7	5	14	33	15
3	19	4	23	-7	4	4	14	228	204	4	11	0	156	-143	4	16	18	118	119	7	5	15	33	15
3	19	5	60	56	4	4	15	203	204	4	11	1	77	-69	4	16	19	118	12	7	5	16	33	15
3	20	1	74	-74	4	4	16	28	23	4	11	2	162	151	4	16	20	88	44	7	5	17	33	15
3	20	2	24	31	4	4	17	79	34	4	11	3	48	-42	4	16	21	22	44	7	5	18	33	15
3	20	3	36	-21	4	4	18	176	-178	4	11	4	50	53	4	16	22	33	14	7	5	19	33	15
3	20	4	44	16	4	4	19	121	-131	4	11	5	51	-60	4	16	23	33	89	7	5	20	33	15
3	20	5	40	-44	4	4	20	98	97	4	11	6	243	234	4	16	24	33	28	7	5	21	33	15
3	21	1	19	16	4	4	21	67	67	4	11	7	450	433	4	16	25	33	98	7	5	22	33	15
3	21	2	24	-16	4	4	22	484	434	4	11	8	29	21	4	16	26	33	98	7	5	23	33	15
3	21	3	18	16	4	4	23	73	-65	4	11	9	213	-219	4	16	27	33	74	7	5	24	33	15
3	21	4	43	-48	4	4	24	206	208	4	11	10	172	-177	4	16	28	33	22	7	5	25	33	15
3	21	5	50	33	4	4	25	336	347	4	11	11	36	20	4	16	29	82	75	7	5	26	33	15
3	22	1	24	-29	4	4	26	140	143	4	11	12	147	-143	4	16	30	116	114	7	5	27	33	15
3	22	2	12	7	4	4	27	349	355	4	11	13	100	-108	4	16	31	71	75	7	5	28	33	15
3	22	3	30	11	4	4	28	18	16	4	11	14	118	121	4	16	32	71	14	7	5	29	33	15
3	22	4	326	304	4	4	29	92	-97	4	11	15	105	-109	4	16	33	88	12	7	5	30	33	15
3	22	5	11	-3	4	4	30	42	87	4	11	16	43	-47	4	16	34	117	10	7	5	31	33	15
3	23	1	194	-174	4	4	31	30	22	4	11	17	380	341	4	16	35	175	34	7	5	32	33	15
3	23	2	53	50	4	4	32	25	-15	4	11	18	198	-189	4	16	36	33	33	7	5	33	33	15
3	23	3	77	-55	4	4	33	90	-92	4	11	19	332	338	4	16	37	66	64	7	5	34	33	15
3	23	4	79	92	4	4	34	134	136	4	11	20	43	-31	4	16	38	55	77	7	5	35	33	15
3	23	5	175	-170	4	4	35	84	79	4	11	21	106	100	4	16	39	2	43	7	5	36	33	15
3	24	1	242	224	4	4	36	50	-41	4	11	22	157	152	4	16	40	2	40	7	5	37	33	15
3	24	2	72	-44	4	4	37	589	582	4	11	23	86	85	4	16	41	2	38	7	5	38	33	15
3	24	3	132	111	4	4	38	248	-253	4	11	24	62	-68	4	16	42	2	33	7	5	39	33	15
3	24	4	55	-44	4	4	39	24	79	4	11	25	192	-187	4	16	43	2	35	7	5	40	33	15
3	24	5	89	89	4	4	40	32	336	4	11	26	61	54	4	16	44	2	26	7	5	41	33	15
3	25	1	46	-25	4	4	41	191	-194	4	11	27	312	275	4	16	45	2	27	7	5	42	33	15
3	25	2	63	55	4	4	42	25	16	4	11	28	87	84	4	16	46	2	28	7	5	43	33	15
3	25	3	33	-2	4	4	43	24	10	4	11	29	183	173	4	16	47	2	28	7	5	44	33	15
3	25	4	130	133	4	4	44	121	-114	4	11	30	60	59	4	16	48	2	28	7	5	45	33	15

OBSERVED AND CALCULATED STRUCTURE FACTORS FOR CIS-((MU-CL).(MU-SPH)(PTCLPET3)2)

H	K	L	FO	FC	H	K	L	FO	FC	H	K	L	FO	FC	H	K	L	FO	FC	H	K	L	FO	FC
7	7	7	28		7	8	3	236	-248	7	16	2	211		8	8	5	18	23	8	8	6	81	74
7	7	7	55		7	7	5	198	200	7	16	2	221		8	8	2	53	14	8	8	2	233	226
7	7	7	53		7	8	5	181	182	7	16	5	161		8	8	2	56	14	8	8	2	91	100
7	7	7	54		7	8	5	92	187	7	17	5	165		8	8	3	33	23	8	8	2	211	206
7	7	7	51		7	9	1	79	78	7	17	3	121		8	8	3	38	23	8	8	2	45	28
7	7	7	74		7	9	1	81	92	7	17	3	78		8	8	3	41	23	8	8	2	184	173
7	7	7	74		7	9	2	115	118	7	17	4	87		8	8	3	77	63	8	8	2	70	67
7	7	7	77		7	9	2	110	118	7	18	1	115		8	8	3	58	67	8	8	2	32	53
7	7	7	77		7	9	2	34	11	7	18	2	121		8	8	3	64	67	8	8	2	111	33
7	7	7	77		7	9	2	103	94	7	18	3	204		8	8	3	164	164	8	8	2	162	176
7	7	7	77		7	9	2	44	44	7	18	4	148		8	8	4	55	48	8	8	2	42	48
7	7	7	77		7	9	2	43	44	7	18	5	87		8	8	4	121	111	8	8	2	70	64
7	7	7	77		7	9	2	22	21	7	19	1	204		8	8	4	42	407	8	8	2	43	34
7	7	7	77		7	9	2	76	77	7	19	2	74		8	8	4	117	110	8	8	2	117	22
7	7	7	77		7	9	2	35	32	7	19	3	19		8	8	4	92	84	8	8	2	54	54
7	7	7	77		7	9	2	27	22	7	19	4	62		8	8	4	72	63	8	8	2	107	55
7	7	7	77		7	9	2	99	99	7	19	5	24		8	8	4	88	66	8	8	2	33	33
7	7	7	77		7	9	2	74	66	7	20	0	22		8	8	4	57	47	8	8	2	53	53
7	7	7	77		7	9	2	49	46	7	20	0	160		8	8	4	33	33	8	8	2	184	184
7	7	7	77		7	9	2	121	122	7	20	0	136		8	8	5	33	33	8	8	2	55	55
7	7	7	77		7	9	2	88	88	7	20	0	104		8	8	5	33	33	8	8	2	184	184
7	7	7	77		7	9	2	67	66	7	20	0	104		8	8	5	33	33	8	8	2	184	184
7	7	7	77		7	9	2	65	62	7	21	1	31		8	8	5	199	188	8	8	2	168	173
7	7	7	77		7	9	2	66	64	7	21	1	19		8	8	5	119	114	8	8	2	155	164
7	7	7	77		7	9	2	99	99	7	21	1	63		8	8	5	137	124	8	8	2	71	73
7	7	7	77		7	9	2	55	55	7	21	1	55		8	8	5	195	191	8	8	2	81	89
7	7	7	77		7	9	2	99	99	7	21	2	164		8	8	6	51	51	8	8	2	86	63
7	7	7	77		7	9	2	55	55	7	21	2	71		8	8	6	127	133	8	8	2	193	183
7	7	7	77		7	9	2	27	27	7	21	2	30		8	8	6	143	144	8	8	2	120	111
7	7	7	77		7	9	2	88	88	7	21	2	107		8	8	6	173	172	8	8	2	70	75
7	7	7	77		7	9	2	44	44	7	21	3	44		8	8	6	71	77	8	8	2	63	69
7	7	7	77		7	9	2	44	44	7	21	3	47		8	8	6	46	33	8	8	2	145	155
7	7	7	77		7	9	2	33	33	7	21	3	63		8	8	6	33	33	8	8	2	46	41
7	7	7	77		7	9	2	17	16	7	21	3	177		8	8	6	76	65	8	8	2	272	270
7	7	7	77		7	9	2	117	117	7	21	3	49		8	8	6	44	41	8	8	2	197	199
7	7	7	77		7	9	2	44	44	7	21	4	49		8	8	6	33	33	8	8	2	38	38
7	7	7	77		7	9	2	33	33	7	21	4	360		8	8	6	120	75	8	8	2	107	104
7	7	7	77		7	9	2	50	50	7	21	4	111		8	8	6	75	65	8	8	2	97	99
7	7	7	77		7	9	2	50	50	7	21	4	64		8	8	6	15	21	8	8	2	14	14
7	7	7	77		7	9	2	146	142	7	21	5	149		8	8	6	180	182	8	8	2	19	22
7	7	7	77		7	9	2	27	23	7	21	5	151		8	8	6	103	103	8	8	2	92	95
7	7	7	77		7	9	2	104	104	7	21	5	137		8	8	6	279	288	8	8	2	24	24
7	7	7	77		7	9	2	47	33	7	21	5	165		8	8	6	172	188	8	8	2	43	43
7	7	7	77		7	9	2	72	71	7	21	5	64		8	8	6	306	323	8	8	2	93	93
7	7	7	77		7	9	2	55	55	7	21	5	52		8	8	6	213	222	8	8	2	21	21
7	7	7	77		7	9	2	74	77	7	21	5	60		8	8	6	44	44	8	8	2	27	28
7	7	7	77		7	9	2	61	61	7	21	5	61		8	8	6	105	106	8	8	2	39	44

OBSERVED AND CALCULATED STRUCTURE FACTORS FOR CIS-((MU-CL).(MU-SPH)(PTCLPET3)2)

H	K	L	FO	FC	H	K	L	FO	FC	H	K	L	FO	FC	H	K	L	FO	FC	H	K	L	FO	FC
8	16	3	111	125	9	2	7	122	115	9	11	5	102	-99	10	0	4	238	-247	10	7	5	61	-41
8	16	5	115	-111	9	3	2	135	124	9	11	6	56	32	10	0	6	297	-285	10	7	6	47	-24
8	16	7	80	-85	9	3	3	275	276	9	11	7	102	109	10	0	0	317	-285	10	8	8	169	185
8	17	0	90	-90	9	3	3	73	-76	9	11	8	128	-117	10	1	1	264	-287	10	8	8	263	-263
8	17	1	22	-38	9	3	4	63	-40	9	11	9	30	-45	10	1	2	255	-287	10	8	9	50	-39
8	17	2	90	-86	9	3	5	84	-74	9	11	10	119	-119	10	1	3	111	-106	10	8	10	147	-44
8	17	3	117	-126	9	3	6	113	-101	9	11	11	65	58	10	1	4	55	-45	10	8	11	33	-139
8	18	0	173	-169	9	3	7	206	206	9	11	12	81	-96	10	1	5	17	-33	10	8	12	99	-92
8	18	1	35	-55	9	3	8	402	383	9	11	13	40	-43	10	1	6	44	-20	10	9	13	20	-33
8	18	2	138	145	9	3	9	84	-83	9	11	14	225	-240	10	1	7	37	-7	10	9	14	55	-26
8	18	3	74	-83	9	3	10	280	-274	9	11	15	66	-73	10	1	8	86	-91	10	9	15	48	-35
8	18	4	78	-83	9	3	11	63	-71	9	11	16	74	-82	10	1	9	34	-94	10	9	16	42	-35
8	19	0	72	-81	9	3	12	206	186	9	11	17	61	-63	10	1	10	57	-55	10	9	17	50	-38
8	19	1	32	-39	9	3	13	73	-63	9	11	18	45	-43	10	1	11	2	-240	10	9	18	3	-38
8	19	2	34	-31	9	3	14	110	-120	9	11	19	114	112	10	1	12	2	-32	10	9	19	0	-49
8	19	3	101	-108	9	3	15	169	-174	9	11	20	26	8	10	1	2	-33	-252	10	9	20	11	-11
8	20	0	72	-70	9	3	16	206	206	9	11	21	155	18	10	1	23	1	12	10	10	21	1	-49
8	20	1	126	132	9	3	17	129	-125	9	11	22	26	-206	10	1	24	1	-151	10	10	22	1	-49
8	20	2	68	-66	9	3	18	236	-227	9	11	23	186	-206	10	1	25	1	-166	10	10	23	1	-38
8	20	3	61	-66	9	3	19	36	-224	9	11	24	17	-9	10	1	26	1	-166	10	10	24	1	-38
8	20	4	76	-79	9	3	20	225	-224	9	11	25	148	164	10	1	27	1	-167	10	10	25	1	-45
8	21	0	15	-66	9	3	21	139	-129	9	11	26	226	-63	10	1	28	1	-105	10	10	26	1	-45
8	21	1	76	-76	9	3	22	196	-183	9	11	27	64	-46	10	1	29	1	-41	10	10	27	1	-72
8	21	2	119	-103	9	3	23	63	-72	9	11	28	35	-75	10	1	30	1	-31	10	10	28	1	-33
8	21	3	71	-89	9	3	24	116	-127	9	11	29	56	-26	10	1	31	1	-52	10	10	29	1	-16
8	21	4	72	-59	9	3	25	2	-240	9	11	30	106	-97	10	1	32	1	-193	10	10	30	1	-35
8	22	0	47	-79	9	3	26	53	-47	9	11	31	132	-144	10	1	33	1	-83	10	10	31	1	-11
8	22	1	75	-79	9	3	27	82	-84	9	11	32	42	-47	10	1	34	1	-193	10	10	32	1	-11
8	22	2	39	-43	9	3	28	44	-55	9	11	33	173	180	10	1	35	1	-16	10	10	33	1	-11
8	22	3	108	-96	9	3	29	261	-264	9	11	34	102	-111	10	1	36	1	-87	10	10	34	1	-11
8	22	4	66	-56	9	3	30	101	-102	9	11	35	45	-32	10	1	37	1	-112	10	10	35	1	-11
8	23	0	320	-305	9	3	31	159	-157	9	11	36	26	-10	10	1	38	1	-112	10	10	36	1	-11
8	23	1	230	-199	9	3	32	103	-103	9	11	37	36	-26	10	1	39	1	-69	10	10	37	1	-11
8	23	2	154	-196	9	3	33	113	-118	9	11	38	65	-72	10	1	40	1	-58	10	10	38	1	-11
8	23	3	275	-254	9	3	34	74	-92	9	11	39	147	-157	10	1	41	1	-61	10	10	39	1	-11
8	23	4	181	-175	9	3	35	238	-269	9	11	40	134	-136	10	1	42	1	-43	10	10	40	1	-11
8	24	0	54	-22	9	3	36	55	-51	9	11	41	60	-47	10	1	43	1	-43	10	10	41	1	-11
8	24	1	195	-168	9	3	37	119	-170	9	11	42	17	-4	10	1	44	1	-201	10	10	42	1	-11
8	24	2	179	-185	9	3	38	41	-30	9	11	43	10	-30	10	1	45	1	-170	10	10	43	1	-11
8	24	3	432	-374	9	3	39	124	-125	9	11	44	41	-30	10	1	46	1	-87	10	10	44	1	-11
8	24	4	54	-55	9	3	40	134	-134	9	11	45	123	-122	10	1	47	1	-201	10	10	45	1	-11
8	25	0	344	-334	9	3	41	133	-129	9	11	46	124	-133	10	1	48	1	-299	10	10	46	1	-11
8	25	1	30	-33	9	3	42	230	-231	9	11	47	23	-11	10	1	49	1	-383	10	10	47	1	-11
8	25	2	285	-299	9	3	43	35	-20	9	11	48	10	-11	10	1	50	1	-383	10	10	48	1	-11
8	25	3	30	-29	9	3	44	35	-20	9	11	49	10	-11	10	1	51	1	-383	10	10	49	1	-11
8	25	4	30	-29	9	3	45	35	-20	9	11	50	10	-11	10	1	52	1	-383	10	10	50	1	-11

OBSERVED AND CALCULATED STRUCTURE FACTORS FOR CIS-((MU-CL).(MU-SPH)(PTCLPET3)2)

PAGE 7

H	K	L	FO	FC	H	K	L	FO	FC	H	K	L	FO	FC	H	K	L	FO	FC	H	K	L	FO	FC
10	15	3	104	103	11	2	4	44	35	11	11	2	113	135	11	2	3	171	134	11	2	3	54	40
10	15	4	76	58	11	2	5	207	195	11	11	3	118	130	11	2	4	50	228	11	2	4	39	72
10	16	1	170	167	11	2	6	43	31	11	11	4	40	45	11	2	5	150	123	11	2	5	278	316
10	16	2	230	246	11	3	1	76	87	11	11	5	118	123	11	3	1	80	68	11	3	1	61	75
10	16	3	91	107	11	3	2	206	205	11	11	6	72	85	11	3	2	133	128	11	3	2	177	217
10	16	4	102	112	11	3	3	243	239	11	11	7	208	241	11	3	3	86	95	11	3	3	121	135
10	16	5	20	8	11	3	4	147	146	11	11	8	80	86	11	3	4	188	193	11	3	4	206	338
10	16	6	19	16	11	3	5	147	159	11	11	9	91	90	11	3	5	205	190	11	3	5	119	123
10	17	0	121	115	11	3	6	43	59	11	11	10	107	119	11	3	6	190	208	11	3	6	46	8
10	17	1	97	106	11	4	2	448	438	11	11	11	89	114	11	4	2	123	111	11	4	2	88	123
10	17	2	39	48	11	4	3	46	41	11	11	12	96	108	11	4	3	195	205	11	4	3	90	115
10	17	3	80	92	11	4	4	227	227	11	11	13	48	44	11	4	4	70	71	11	4	4	50	20
10	17	4	44	46	11	4	5	63	64	11	11	14	121	126	11	4	5	48	54	11	4	5	67	77
10	17	5	57	54	11	4	6	100	73	11	11	15	106	121	11	4	6	51	64	11	4	6	94	94
10	18	0	228	228	11	5	1	189	187	11	11	16	83	96	11	5	1	209	209	11	5	1	22	222
10	18	1	156	164	11	5	2	212	209	11	11	17	106	112	11	5	2	149	147	11	5	2	244	31
10	18	2	151	152	11	5	3	181	182	11	11	18	83	96	11	5	3	228	228	11	5	3	244	51
10	18	3	78	78	11	5	4	157	165	11	11	19	67	92	11	5	4	102	109	11	5	4	100	112
10	18	4	53	51	11	5	5	49	79	11	11	20	83	76	11	5	5	142	146	11	5	5	70	66
10	19	0	125	130	11	6	0	155	156	11	11	21	46	26	11	6	0	167	174	11	6	0	138	156
10	19	1	38	32	11	6	1	194	199	11	11	22	70	62	11	6	1	144	150	11	6	1	138	87
10	19	2	54	76	11	6	2	225	229	11	11	23	114	135	11	6	2	186	191	11	6	2	69	94
10	19	3	32	33	11	6	3	308	309	11	11	24	47	58	11	6	3	123	130	11	6	3	69	123
10	19	4	77	92	11	6	4	88	85	11	11	25	84	97	11	6	4	88	99	11	6	4	33	32
10	20	0	186	181	11	6	5	154	145	11	11	26	16	21	11	6	5	44	48	11	6	5	33	44
10	20	1	155	168	11	6	6	87	76	11	11	27	63	51	11	6	6	44	48	11	6	6	67	72
10	20	2	115	124	11	6	7	43	52	11	11	28	61	74	11	6	7	2	312	11	6	7	47	63
10	20	3	69	71	11	7	1	245	243	11	11	29	23	40	11	7	1	78	89	11	7	1	73	85
10	20	4	67	76	11	7	2	200	202	11	11	30	76	74	11	7	2	143	157	11	7	2	45	66
10	21	0	78	85	11	7	3	96	106	11	11	31	21	22	11	7	3	127	148	11	7	3	61	95
10	21	1	125	135	11	7	4	168	167	11	11	32	17	24	11	7	4	160	184	11	7	4	48	74
10	21	2	157	146	11	7	5	50	50	11	11	33	48	55	11	7	5	144	150	11	7	5	64	107
10	21	3	65	83	11	8	0	345	355	11	11	34	57	55	11	8	0	155	162	11	8	0	64	107
10	21	4	56	67	11	8	1	105	95	11	11	35	56	40	11	8	1	86	94	11	8	1	79	76
10	22	0	80	90	11	8	2	165	162	11	11	36	12	22	11	8	2	122	132	11	8	2	51	78
10	22	1	66	59	11	8	3	105	114	11	11	37	46	28	11	8	3	148	166	11	8	3	46	62
10	22	2	129	127	11	8	4	152	157	11	11	38	32	30	11	8	4	171	195	11	8	4	33	57
10	22	3	70	67	11	9	0	144	151	11	11	39	24	38	11	9	0	46	37	11	9	0	44	72
10	22	4	473	433	11	9	1	80	92	11	11	40	65	84	11	9	1	55	60	11	9	1	19	23
11	0	0	231	235	11	9	2	159	151	11	11	41	19	24	11	9	2	102	99	11	9	2	123	154
11	1	0	94	79	11	9	3	41	30	11	11	42	43	30	11	9	3	2	112	11	9	3	17	26
11	1	1	237	227	11	9	4	132	130	11	11	43	21	92	11	9	4	90	107	11	9	4	2	88
11	1	2	168	153	11	10	0	143	156	11	11	44	47	88	11	10	0	11	134	11	10	0	2	9
11	1	3	160	149	11	10	1	2	217	11	11	45	185	184	11	10	1	89	88	11	10	1	2	70
11	1	4	141	143	11	10	2	99	91	11	11	46	191	188	11	10	2	128	130	11	10	2	2	55
11	1	5	300	285	11	10	3	90	87	11	11	47	46	55	11	10	3	148	154	11	10	3	1	175
11	1	6	221	248	11	10	4	122	124	11	11	48	34	66	11	10	4	48	51	11	10	4	1	9
11	1	7	328	308	11	11	0	56	79	11	11	49	42	42	11	11	0	10	127	11	11	0	1	4

OBSERVED AND CALCULATED STRUCTURE FACTORS FOR CIS-((MU-CL).(MU-SPH)(PTCLPET3)2)

PAGE 8

H	K	L	FO	FC	H	K	L	FO	FC	H	K	L	FO	FC	H	K	L	FO	FC	H	K	L	FO	FC
12	23	20	150	184	13	10	2	84	107	14	3	5	105	77	14	12	5	60	-65	15	9	4	89	-82
13	0	0	158	167	13	10	3	90	-111	14	4	6	71	-16	14	13	1	50	-45	15	5	5	76	74
13	0	0	206	186	13	10	4	108	-125	14	4	7	453	400	14	13	2	78	-111	15	10	10	72	-59
13	1	1	208	187	13	11	1	99	-128	14	4	4	96	-79	14	13	4	54	87	15	10	3	56	50
13	1	1	186	166	13	11	2	39	-73	14	4	2	304	-277	14	14	0	63	-62	15	10	4	76	57
13	1	1	120	133	13	11	3	128	164	14	4	4	49	39	14	14	4	62	-82	15	10	10	29	32
13	1	1	132	133	13	11	4	21	-122	14	4	4	53	-51	14	15	0	23	-63	15	11	5	24	39
13	1	1	129	133	13	11	5	113	-122	14	4	4	28	-24	14	15	1	72	-90	15	11	2	219	-206
13	1	1	153	166	13	11	6	59	71	14	4	4	172	173	14	15	2	51	77	15	11	1	46	-28
13	1	1	151	166	13	12	1	33	-38	14	4	5	259	256	14	15	3	15	71	15	11	1	195	180
13	1	1	116	133	13	12	2	137	-158	14	4	5	140	-192	14	15	4	88	-108	15	11	1	12	-35
13	1	1	114	133	13	12	3	60	49	14	4	5	285	-280	14	15	5	43	-47	15	12	2	69	67
13	1	1	229	200	13	12	4	77	119	14	4	5	62	-44	14	16	1	46	57	15	13	1	71	-62
13	1	1	100	106	13	13	1	22	0	14	4	6	85	-89	14	16	2	60	23	15	13	3	36	-70
13	1	1	164	141	13	13	2	122	135	14	4	6	306	-321	14	16	3	59	-38	15	13	3	241	220
13	1	1	170	166	13	13	3	92	55	14	4	6	105	94	14	16	4	69	-84	15	13	4	77	66
13	1	1	90	99	13	14	1	32	55	14	4	6	75	73	14	17	1	19	76	15	14	1	65	-38
13	1	1	338	336	13	14	2	123	-114	14	4	6	137	136	14	17	1	44	26	15	14	1	93	-74
13	1	1	111	111	13	15	1	114	120	14	4	7	123	104	14	17	2	56	-107	15	14	1	29	-57
13	1	1	163	159	13	15	2	33	22	14	4	7	263	-279	14	18	1	20	24	15	15	2	30	39
13	1	1	182	184	13	16	1	46	-79	14	4	7	53	-75	14	18	2	40	76	15	15	2	177	168
13	1	1	466	457	13	16	2	53	52	14	4	7	137	158	14	19	0	35	-85	15	16	3	62	-74
13	1	1	113	113	13	16	3	45	77	14	4	7	68	-66	14	19	1	14	10	15	16	3	50	60
13	1	1	184	184	13	17	1	58	-56	14	4	8	55	-63	14	20	0	38	8	15	17	1	217	-187
13	1	1	61	61	13	17	2	70	-89	14	4	8	260	-283	14	20	1	29	-27	15	17	1	46	-59
13	1	1	338	336	13	17	3	30	62	14	4	8	99	123	14	21	1	72	-79	15	17	2	114	-117
13	1	1	74	74	13	18	1	64	102	14	4	8	150	181	14	21	1	56	-20	15	18	1	41	-44
13	1	1	94	94	13	18	2	37	-93	14	4	8	75	-44	14	21	2	30	-74	15	18	2	69	-53
13	1	1	95	110	13	19	1	29	-40	14	4	9	53	-54	14	22	0	80	83	15	19	1	72	82
13	1	1	61	61	13	20	1	17	-77	14	4	9	201	-244	14	23	3	81	-73	15	20	1	72	82
13	1	1	85	88	14	0	0	0	-46	14	4	9	36	-51	14	24	4	74	88	15	21	1	279	259
13	1	1	96	96	14	0	0	300	278	14	4	9	103	-112	14	24	4	81	9	15	21	1	273	255
13	1	1	207	207	14	0	0	39	70	14	4	9	36	85	14	24	4	74	88	15	21	2	258	248
13	1	1	64	64	14	0	0	167	175	14	4	10	92	101	14	25	5	38	-23	15	22	5	52	-90
13	1	1	147	153	14	0	0	50	-25	14	4	10	166	-205	14	25	5	69	61	15	22	5	60	65
13	1	1	50	53	14	1	1	146	-24	14	4	10	83	-114	14	26	6	49	-94	15	22	5	81	-48
13	1	1	127	143	14	1	1	49	458	14	4	10	95	121	14	26	6	51	-38	15	22	5	96	88
13	1	1	117	144	14	2	2	54	-41	14	4	11	103	-131	14	27	7	61	-72	15	22	5	41	6
13	1	1	338	338	14	2	2	28	16	14	4	11	37	78	14	27	7	158	174	15	23	5	104	-103
13	1	1	110	109	14	2	2	156	-176	14	4	11	67	70	14	27	7	123	-137	15	23	5	256	221
13	1	1	175	175	14	2	2	31	17	14	4	11	37	78	14	27	7	77	-97	15	23	5	312	285
13	1	1	38	36	14	2	2	159	166	14	4	11	49	-85	14	27	7	22	-86	15	23	5	157	-146
13	1	1	164	168	14	2	2	37	-123	14	4	12	37	76	14	28	8	45	61	15	23	5	133	127
13	1	1	42	42	14	3	3	160	123	14	4	12	34	-36	14	28	8	20	-60	15	23	5	101	78
13	1	1			14	3	3			14	4	12			14	28	8	232	-215	15	24	4	107	

OBSERVED AND CALCULATED STRUCTURE FACTORS FOR CIS-((MU-CL), (MU-SPH) (PTCLPET3)2)

H	K	L	FO	FC	H	K	L	FO	FC	H	K	L	FO	FC	H	K	L	FO	FC	H	K	L	FO	FC
16	4	3	47	-22	16	14	3	108	-101	17	10	4	50	3	18	9	1	139	137	19	9	3	75	74
16	4	4	121	-109	16	14	3	43	-33	17	11	2	80	72	18	9	2	170	154	19	9	3	64	-58
16	5	5	319	-285	16	15	3	169	-150	17	11	3	35	30	18	9	3	23	19	19	10	3	31	5
16	5	5	174	-155	16	15	3	77	-62	17	11	4	49	-53	18	10	0	62	41	19	11	1	57	59
16	5	5	293	-265	16	15	3	73	-60	17	11	2	121	111	18	10	1	72	-72	19	11	2	74	46
16	5	5	60	-28	16	16	0	111	-110	17	12	3	13	9	18	10	2	69	-64	19	12	1	18	-48
16	5	5	49	-24	16	16	0	113	-111	17	12	3	32	-7	18	10	3	18	-22	19	12	2	41	17
16	5	5	128	-122	16	16	2	47	50	17	13	3	89	-83	18	11	0	181	-175	19	12	0	210	201
16	6	6	141	-134	16	16	3	52	46	17	14	3	34	54	18	11	1	137	-124	20	0	0	55	45
16	6	6	162	-148	16	16	3	153	-132	17	14	3	115	-101	18	11	2	114	-104	20	0	0	75	44
16	6	6	67	-98	16	17	1	76	-66	17	15	1	17	-15	18	11	3	136	-135	20	0	1	133	-151
16	6	6	102	-101	16	17	1	65	-60	17	15	2	66	-74	18	12	0	82	-71	20	0	3	53	-12
16	6	6	153	-139	16	18	0	133	-110	17	16	2	58	-59	18	12	1	60	-41	20	0	0	206	-196
16	6	6	303	-279	16	18	1	94	-78	18	0	0	98	-92	18	12	2	59	-49	20	0	2	52	53
16	6	6	44	-54	16	19	0	89	-77	18	0	4	88	-108	18	12	3	53	-45	20	0	5	84	-74
16	6	6	149	-147	17	0	0	252	-236	18	0	4	135	-157	18	13	0	144	-114	20	0	5	19	29
16	6	6	124	-105	17	0	4	269	-252	18	0	2	27	-25	18	13	1	205	-184	20	0	2	68	124
16	6	6	84	-100	17	1	1	87	-89	18	0	4	41	6	18	13	2	108	-109	20	0	1	107	-72
16	6	6	173	-155	17	1	5	122	-110	18	0	0	31	52	18	14	2	74	-74	20	0	1	140	141
16	6	6	55	-55	17	1	7	67	-73	18	0	1	78	70	18	14	2	72	-58	20	0	1	79	53
16	6	6	42	-66	17	1	3	326	-300	18	0	2	35	-52	18	15	0	253	-210	20	0	1	111	107
16	6	6	102	-94	17	1	3	140	-136	18	0	3	177	-182	18	15	1	110	-87	20	0	2	29	-38
16	6	6	304	-267	17	1	3	117	-112	18	0	4	126	-124	18	16	0	92	-83	20	0	2	26	200
16	6	6	40	-45	17	1	3	69	-50	18	0	4	90	-96	18	16	1	59	-46	20	0	1	27	34
16	6	6	227	-200	17	1	4	134	-140	18	0	1	42	-31	19	1	1	97	-103	20	0	1	104	73
16	6	6	34	-45	17	1	4	226	-203	18	0	3	29	-15	19	1	3	172	-206	20	0	1	73	-81
16	6	6	166	-156	17	1	4	247	-229	18	0	4	119	-124	19	1	4	196	-207	20	0	2	12	-114
16	6	6	99	-99	17	1	5	24	-20	18	0	0	104	-89	19	1	3	54	-50	20	0	0	5	63
16	6	6	121	-114	17	1	3	39	-36	18	0	2	91	-75	19	1	3	92	-100	20	0	1	13	-111
16	6	6	78	-73	17	1	4	51	-49	18	0	2	174	-166	19	1	2	130	-135	20	0	2	36	9
16	6	6	46	-44	17	1	4	115	-102	18	0	3	97	-78	19	1	3	185	-222	20	0	1	13	-112
16	6	6	75	-70	17	1	6	110	-105	18	0	6	160	-154	19	1	4	160	-164	20	0	1	86	-78
16	6	6	2	-2	17	1	7	242	-232	18	0	0	24	-20	19	1	4	36	-3	20	0	1	17	-149
16	6	6	122	-110	17	1	7	43	-49	18	0	1	64	-60	19	1	4	52	-40	20	0	1	5	-33
16	6	6	150	-135	17	1	7	110	-99	18	0	2	34	-42	19	1	5	90	-73	20	0	1	7	64
16	6	6	70	-66	17	1	7	18	-15	18	0	4	43	-33	19	1	5	172	-171	20	0	2	5	-74
16	6	6	143	-122	17	1	8	32	-27	18	0	0	101	-99	19	1	5	163	-151	20	0	1	2	-45
16	6	6	27	-26	17	1	8	173	-161	18	0	1	137	-116	19	1	5	49	-3	20	0	1	4	-42
16	6	6	49	-46	17	1	8	43	-49	18	0	3	51	-35	19	1	6	55	-70	20	0	0	1	-63
16	6	6	76	-73	17	1	8	204	-185	18	0	3	194	-181	19	1	6	51	-16	20	0	0	3	-271
16	6	6	246	-219	17	1	4	17	-17	18	0	4	36	-33	19	1	7	75	-93	20	0	1	1	-202
16	6	6	117	-114	17	1	9	44	-47	18	0	0	61	-57	19	1	7	50	-65	20	0	1	3	-41
16	6	6	150	-137	17	1	4	78	-61	18	0	8	67	-59	19	1	7	220	-201	20	0	1	2	-222
16	6	6	48	-46	17	1	9	108	-87	18	0	8	58	-52	19	1	8	72	-36	20	0	2	5	-227
16	6	6	41	-39	17	1	10	62	-59	18	0	8	67	-55	19	1	8	67	-77	20	0	9	3	-71
16	6	6	136	-123	17	1	10	174	-159	18	0	4	110	-108	19	1	9	156	-141	20	0	2	6	-13
16	6	6	98	-96	17	1	10	174	-169	18	0	9	151	-123	19	1	9	156	-141	20	0	2	8	252

APPENDIX II

Observed and Calculated Structure Factors for $[\text{Pt}_3\text{S}_2(\text{PMe}_2\text{Ph})_6](\text{BEt}_4)_2$

OBSERVED AND CALCULATED STRUCTURE FACTORS FOR (PT3S2(P(CH3)2(C6H5)16) (R(C2H5)4)2

PAGE 1

H	K	L	FO	FC	H	K	L	FO	FC	H	K	L	FO	FC	H	K	L	FO	FC	H	K	L	FO	FC
14	0	2	158	-159	11	34	26	26	26	2	16	51	49	11	1	1	191	-196	11	5	12	73	68	
14	0	2	99	99	12	166	162	162	162	2	17	164	169	11	1	2	274	-273	11	5	13	1	4	
14	0	2	22	14	13	18	10	10	10	4	4	50	56	11	1	3	115	112	11	5	14	24	18	
14	0	2	77	74	14	26	24	24	24	4	2	42	34	11	1	4	187	195	11	5	15	114	-114	
14	0	2	115	118	14	147	146	146	146	4	3	53	53	11	1	5	41	28	11	5	16	26	32	
14	0	2	33	33	14	62	68	68	68	4	4	52	48	11	1	6	84	-90	11	5	17	187	180	
14	0	2	77	77	14	97	103	103	103	4	4	16	13	11	1	7	138	-136	11	5	18	17	11	
14	0	2	84	80	14	121	124	124	124	4	4	168	164	11	1	8	29	29	11	5	19	222	-230	
14	0	2	40	47	14	133	133	133	133	4	4	97	99	11	1	9	133	131	11	5	20	56	49	
14	0	2	66	66	14	128	128	128	128	4	4	281	276	11	1	10	27	-29	11	5	21	117	108	
14	0	2	22	22	14	122	126	126	126	4	4	140	140	11	1	11	78	-84	11	5	22	93	89	
14	0	2	100	100	14	158	154	154	154	4	4	211	211	11	1	12	93	87	11	5	23	31	14	
14	0	2	36	36	14	80	88	88	88	4	4	91	89	11	1	13	41	36	11	5	24	99	89	
14	0	2	70	70	14	99	97	97	97	4	4	123	122	11	1	14	165	-183	11	5	25	72	72	
14	0	2	44	44	14	88	87	87	87	4	4	14	14	11	1	15	66	65	11	5	26	66	65	
14	0	2	00	00	14	201	199	199	199	4	4	204	201	11	1	16	216	223	11	5	27	90	91	
14	0	2	57	57	14	211	211	211	211	4	4	31	37	11	1	17	175	-175	11	5	28	47	49	
14	0	2	10	10	14	233	233	233	233	4	4	49	50	11	1	18	222	-227	11	5	29	29	11	
14	0	2	31	31	14	224	224	224	224	4	6	66	66	11	1	19	154	159	11	5	30	58	63	
14	0	2	00	00	14	122	122	122	122	4	6	66	66	11	1	20	65	-72	11	5	31	125	-122	
14	0	2	44	44	14	333	333	333	333	4	6	66	66	11	1	21	40	44	11	5	32	56	55	
14	0	2	11	11	14	377	377	377	377	4	6	66	66	11	1	22	64	65	11	5	33	77	75	
14	0	2	44	44	14	377	377	377	377	4	6	66	66	11	1	23	83	79	11	5	34	31	38	
14	0	2	10	10	14	265	265	265	265	4	6	66	66	11	1	24	30	28	11	5	35	53	42	
14	0	2	37	37	14	284	281	281	281	4	6	66	66	11	1	25	251	-252	11	5	36	94	95	
14	0	2	11	11	14	189	188	188	188	4	6	66	66	11	1	26	50	49	11	5	37	70	68	
14	0	2	99	99	14	11	10	10	10	4	6	66	66	11	1	27	295	306	11	5	38	152	-145	
14	0	2	40	40	14	11	22	22	22	4	6	66	66	11	1	28	61	50	11	5	39	192	-180	
14	0	2	99	99	14	100	107	107	107	4	6	66	66	11	1	29	227	-234	11	5	40	175	-161	
14	0	2	33	33	14	18	16	16	16	4	6	66	66	11	1	30	32	35	11	5	41	237	-225	
14	0	2	55	55	14	164	160	160	160	4	6	66	66	11	1	31	158	167	11	5	42	182	-169	
14	0	2	11	11	14	253	251	251	251	4	6	66	66	11	1	32	35	37	11	5	43	164	-160	
14	0	2	11	11	14	174	184	184	184	4	6	66	66	11	1	33	54	-64	11	5	44	138	-122	
14	0	2	44	44	14	75	77	77	77	4	6	66	66	11	1	34	51	60	11	5	45	23	18	
14	0	2	11	11	14	200	171	171	171	4	6	66	66	11	1	35	46	-50	11	5	46	128	-122	
14	0	2	44	44	14	90	85	85	85	4	6	66	66	11	1	36	55	61	11	5	47	30	18	
14	0	2	66	66	14	26	17	17	17	4	6	66	66	11	1	37	89	90	11	5	48	87	-81	
14	0	2	107	107	14	107	105	105	105	4	6	66	66	11	1	38	192	198	11	5	49	54	50	
14	0	2	101	101	14	127	127	127	127	4	6	66	66	11	1	39	149	-147	11	5	50	35	36	
14	0	2	127	127	14	151	155	155	155	4	6	66	66	11	1	40	65	58	11	5	51	140	-129	
14	0	2	151	151	14	140	147	147	147	4	6	66	66	11	1	41	158	-155	11	5	52	500	-494	
14	0	2	140	140	14	96	99	99	99	4	6	66	66	11	1	42	44	44	11	5	53	200	-207	
14	0	2	96	96	14	144	144	144	144	4	6	66	66	11	1	43	187	187	11	5	54	35	38	
14	0	2	22	22	14	144	144	144	144	4	6	66	66	11	1	44	147	-147	11	5	55	140	-129	
14	0	2	44	44	14	127	127	127	127	4	6	66	66	11	1	45	65	58	11	5	56	140	-129	
14	0	2	151	151	14	151	155	155	155	4	6	66	66	11	1	46	158	-155	11	5	57	500	-494	
14	0	2	140	140	14	96	99	99	99	4	6	66	66	11	1	47	44	44	11	5	58	200	-207	
14	0	2	96	96	14	144	144	144	144	4	6	66	66	11	1	48	187	187	11	5	59	140	-129	
14	0	2	22	22	14	127	127	127	127	4	6	66	66	11	1	49	65	58	11	5	60	140	-129	
14	0	2	151	151	14	151	155	155	155	4	6	66	66	11	1	50	158	-155	11	5	61	500	-494	
14	0	2	140	140	14	96	99	99	99	4	6	66	66	11	1	51	44	44	11	5	62	200	-207	
14	0	2	96	96	14	144	144	144	144	4	6	66	66	11	1	52	187	187	11	5	63	140	-129	
14	0	2	22	22	14	127	127	127	127	4	6	66	66	11	1	53	65	58	11	5	64	140	-129	
14	0	2	151	151	14	151	155	155	155	4	6	66	66	11	1	54	158	-155	11	5	65	500	-494	
14	0	2	140	140	14	96	99	99	99	4	6	66	66	11	1	55	44	44	11	5	66	200	-207	
14	0	2	96	96	14	144	144	144	144	4	6	66	66	11	1	56	187	187	11	5	67	140	-129	
14	0	2	22	22	14	127	127	127	127	4	6	66	66	11	1	57	65	58	11	5	68	140	-129	
14	0	2	151	151	14	151	155	155	155	4	6	66	66	11	1	58	158	-155	11	5	69	500	-494	
14	0	2	140	140	14	96	99	99	99	4	6	66	66	11	1	59	44	44	11	5	70	200	-207	
14	0	2	96	96	14	144	144	144	144	4	6	66	66	11	1	60	187	187	11	5	71	140	-129	
14	0	2	22	22	14	127	127	127	127	4	6	66	66	11	1	61	65	58	11	5	72	140	-129	
14	0	2	151	151	14	151	155	155	155	4	6	66	66	11	1	62	158	-155	11	5	73	500	-494	
14	0	2	140	140	14	96	99	99	99	4	6	66	66	11	1	63	44	44	11	5	74	200	-207	
14	0	2	96	96	14	144	144	144	144	4	6	66	66	11	1	64	187	187	11	5	75	140	-129	
14	0	2	22	22	14	127	127	127	127	4	6	66	66	11	1	65	65	58	11	5	76	140	-129	
14	0	2	151	151	14	151	155	155	155	4	6	66	66	11	1	66	158	-155	11	5	77	500	-494	
14	0	2	140	140	14	96	99	99	99	4	6	66	66	11	1	67	44	44	11	5	78	200	-207	
14	0	2	96	96	14	144	144	144	144	4	6	66	66	11	1	68	187	187	11	5	79	140	-129	
14	0	2	22	22	14	127	127	127	127	4	6	66	66	11	1	69	65	58	11	5	80	140	-129	
14	0	2	151	151	14	151	155	155	155	4	6	66	66	11	1	70	158	-155	11	5	81	500		

OBSERVED AND CALCULATED STRUCTURE FACTORS FOR (PT3S2(P(CH3)2(C6H5))6) (R(C2H5)4)2

H	K	L	FO	FC	H	K	L	FO	FC	H	K	L	FO	FC	H	K	L	FO	FC	H	K	L	FO	FC
10	0	16	294	307	10	12	8	78	70	10	9	5	36	-35	10	9	15	124	117	10	9	15	124	117
10	18	365	307	307	10	11	8	356	-363	10	9	5	159	157	10	9	15	24	28	10	9	15	24	28
10	20	255	307	307	10	11	1	395	-400	10	9	5	99	94	10	9	17	171	-179	10	9	17	171	-179
10	21	275	307	307	10	11	3	83	85	10	9	5	201	-207	10	9	11	134	126	10	9	11	134	126
10	22	101	307	307	10	11	4	209	216	10	9	5	149	-155	10	9	2	62	-56	10	9	2	62	-56
10	23	137	307	307	10	11	5	150	155	10	9	5	137	136	10	9	3	108	-98	10	9	3	108	-98
10	24	179	307	307	10	11	6	97	-102	10	9	5	103	110	10	9	4	90	82	10	9	4	90	82
10	25	121	307	307	10	11	7	228	-242	10	9	5	37	34	10	9	5	38	39	10	9	5	38	39
10	26	247	307	307	10	11	8	38	45	10	9	5	25	-32	10	9	6	163	-148	10	9	6	163	-148
10	27	239	307	307	10	11	9	202	210	10	9	5	157	-159	10	9	7	64	56	10	9	7	64	56
10	28	221	307	307	10	11	10	83	-93	10	9	5	54	53	10	9	8	284	257	10	9	8	284	257
10	29	186	307	307	10	11	11	115	-112	10	9	5	248	247	10	9	9	163	-140	10	9	9	163	-140
10	30	116	307	307	10	11	12	150	153	10	9	5	84	-91	10	9	10	281	-253	10	9	10	281	-253
10	31	156	307	307	10	11	13	59	65	10	9	5	183	-181	10	9	11	83	70	10	9	11	83	70
10	32	166	307	307	10	11	14	288	-207	10	9	5	86	92	10	9	12	165	148	10	9	12	165	148
10	33	145	307	307	10	11	15	46	47	10	9	5	63	-63	10	9	13	51	40	10	9	13	51	40
10	34	87	307	307	10	11	16	286	300	10	9	5	275	-287	10	9	14	39	30	10	9	14	39	30
10	35	110	307	307	10	11	17	153	-156	10	9	5	36	-40	10	9	13	109	108	10	9	13	109	108
10	36	182	307	307	10	11	18	274	-286	10	9	5	159	154	10	9	13	162	-155	10	9	13	162	-155
10	37	43	307	307	10	11	19	152	158	10	9	5	95	92	10	9	13	82	-75	10	9	13	82	-75
10	38	137	307	307	10	11	20	171	179	10	9	5	50	44	10	9	13	133	121	10	9	13	133	121
10	39	42	307	307	10	11	21	20	-26	10	9	5	116	-108	10	9	13	31	15	10	9	13	31	15
10	40	189	307	307	10	11	22	64	-62	10	9	5	166	-160	10	9	13	63	-49	10	9	13	63	-49
10	41	72	307	307	10	11	23	165	167	10	9	5	54	42	10	9	13	37	35	10	9	13	37	35
10	42	69	307	307	10	11	24	53	56	10	9	5	188	183	10	9	13	51	43	10	9	13	51	43
10	43	8	307	307	10	11	25	159	170	10	9	5	48	-43	10	9	13	504	-508	10	9	13	504	-508
10	44	77	307	307	10	11	26	8	-9	10	9	5	12	7	10	9	13	236	240	10	9	13	236	240
10	45	176	307	307	10	11	27	346	-358	10	9	5	58	54	10	9	13	60	-75	10	9	13	60	-75
10	46	127	307	307	10	11	28	89	-85	10	9	5	175	-165	10	9	13	63	68	10	9	13	63	68
10	47	305	307	307	10	11	29	359	367	10	9	5	42	-48	10	9	13	64	65	10	9	13	64	65
10	48	271	307	307	10	11	30	191	194	10	9	5	247	238	10	9	13	95	99	10	9	13	95	99
10	49	31	307	307	10	11	31	292	-301	10	9	5	19	17	10	9	14	216	-227	10	9	14	216	-227
10	50	154	307	307	10	11	32	141	-146	10	9	5	236	-237	10	9	14	309	327	10	9	14	309	327
10	51	7	307	307	10	11	33	195	202	10	9	5	51	43	10	9	14	344	-354	10	9	14	344	-354
10	52	26	307	307	10	11	34	20	12	10	9	5	106	-97	10	9	14	252	256	10	9	14	252	256
10	53	90	307	307	10	11	35	84	-89	10	9	5	51	-42	10	9	14	73	-72	10	9	14	73	-72
10	54	252	307	307	10	11	36	30	38	10	9	5	78	74	10	9	14	349	-348	10	9	14	349	-348
10	55	90	307	307	10	11	37	75	-70	10	9	5	117	113	10	9	14	80	80	10	9	14	80	80
10	56	114	307	307	10	11	38	178	166	10	9	5	6	15	10	9	14	113	118	10	9	14	113	118
10	57	66	307	307	10	11	39	30	19	10	9	5	198	-168	10	9	14	215	216	10	9	14	215	216
10	58	113	307	307	10	11	40	143	130	10	9	5	136	-119	10	9	14	147	151	10	9	14	147	151
10	59	160	307	307	10	11	41	203	-187	10	9	5	203	187	10	9	14	264	-275	10	9	14	264	-275
10	60	77	307	307	10	11	42	223	230	10	9	5	187	-179	10	9	14	353	-376	10	9	14	353	-376
10	61	65	307	307	10	11	43	130	118	10	9	5	181	-168	10	9	14	243	257	10	9	14	243	257
10	62	51	307	307	10	11	44	123	109	10	9	5	181	-168	10	9	14	340	355	10	9	14	340	355
10	63	51	307	307	10	11	45	130	118	10	9	5	138	133	10	9	14	236	247	10	9	14	236	247
10	64	51	307	307	10	11	46	126	-110	10	9	5	18	10	10	9	14	245	-255	10	9	14	245	-255
10	65	51	307	307	10	11	47	87	75	10	9	5	74	72	10	9	14	148	151	10	9	14	148	151

OBSERVED AND CALCULATED STRUCTURE FACTORS FOR (PT3SP(P(CH3)2(C6H5)16) (R(C2H5)4)2

H	K	L	FO	FC	H	K	L	FO	FC	H	K	L	FO	FC	H	K	L	FO	FC	H	K	L	FO	FC
13	45	46			6	17	156	154	-8	12	8	109	102	-7	3	13	40	32	-7	7	16	308	305	
14	116	121			6	18	228	229	-8	12	9	145	138	-7	3	14	50	-53	-7	7	17	16	-22	
15	143	149			6	19	109	-108	-8	12	10	65	-60	-7	3	15	28	10	-7	7	18	302	-293	
16	105	108			6	20	175	176	-8	12	11	86	78	-7	3	16	97	-99	-7	7	19	1	6	
17	177	184			6	21	24	34	-8	12	12	58	61	-7	3	17	47	-49	-7	7	20	215	218	
18	205	207			8	22	205	191	-8	12	13	59	57	-7	3	18	83	86	-7	7	21	11	-7	
19	159	159			8	23	159	-140	-8	14	1	38	11	-7	3	19	21	24	-7	9	9	1	-206	
20	103	103			8	24	103	94	-8	14	2	174	-164	-7	3	20	29	20	-7	9	2	45	-49	
21	207	207			8	25	207	187	-8	14	3	23	28	-7	3	21	21	28	-7	9	3	95	95	
22	65	65			8	26	65	54	-8	14	4	98	91	-7	3	22	124	-121	-7	9	4	84	78	
23	58	58			8	27	58	56	-8	14	5	67	64	-7	3	23	62	-71	-7	9	5	90	90	
24	219	219			8	28	219	201	-8	14	6	23	44	-7	3	24	409	419	-7	9	6	225	-205	
25	337	337			8	29	337	17	-8	14	7	110	95	-7	3	25	170	-174	-7	9	7	203	-191	
26	159	159			8	30	159	145	-7	14	8	255	-248	-7	3	26	187	-182	-7	9	8	226	210	
27	103	103			8	31	103	14	-7	14	9	338	-334	-7	3	27	157	153	-7	9	9	289	262	
28	207	207			8	32	207	149	-7	14	10	130	-136	-7	3	28	60	-62	-7	9	10	207	-197	
29	65	65			8	33	65	43	-7	14	11	222	228	-7	3	29	257	-259	-7	9	11	153	-141	
30	58	58			8	34	58	9	-7	14	12	222	228	-7	3	30	257	-259	-7	9	12	137	126	
31	219	219			8	35	219	161	-7	14	13	47	49	-7	3	31	160	162	-7	9	13	36	35	
32	159	159			8	36	159	112	-7	14	14	40	45	-7	3	32	226	230	-7	9	14	59	-59	
33	103	103			8	37	103	177	-7	14	15	221	-244	-7	3	33	241	-240	-7	9	15	17	16	91
34	207	207			8	38	207	172	-7	14	16	288	297	-7	3	34	239	-227	-7	9	16	68	68	
35	65	65			8	39	65	172	-7	14	17	16	14	-7	3	35	178	177	-7	9	17	16	13	
36	58	58			8	40	58	136	-7	14	18	240	254	-7	3	36	180	174	-7	9	18	162	-163	
37	219	219			8	41	219	121	-7	14	19	62	65	-7	3	37	36	34	-7	9	19	23	28	
38	159	159			8	42	159	44	-7	14	20	22	29	-7	3	38	151	-150	-7	9	20	131	128	
39	103	103			8	43	103	22	-7	14	21	23	29	-7	3	39	190	-198	-7	9	21	186	190	
40	207	207			8	44	207	21	-7	14	22	175	182	-7	3	40	186	187	-7	9	22	34	29	
41	65	65			8	45	65	52	-7	14	23	156	164	-7	3	41	249	246	-7	9	23	114	-110	
42	58	58			8	46	58	43	-7	14	24	255	267	-7	3	42	98	-96	-7	9	24	76	74	
43	219	219			8	47	219	243	-7	14	25	139	-143	-7	3	43	199	-207	-7	9	25	30	17	
44	159	159			8	48	159	52	-7	14	26	249	-256	-7	3	44	94	102	-7	9	26	172	-164	
45	103	103			8	49	103	357	-7	14	27	102	103	-7	3	45	64	62	-7	9	27	42	41	
46	207	207			8	50	207	38	-7	14	28	162	163	-7	3	46	129	-134	-7	9	28	231	212	
47	65	65			8	51	65	317	-7	14	29	18	-25	-7	3	47	29	-16	-7	9	29	70	-61	
48	58	58			8	52	58	56	-7	14	30	39	-43	-7	3	48	445	-415	-7	9	30	210	-196	
49	219	219			8	53	219	178	-7	14	31	62	-69	-7	3	49	49	39	-7	9	31	48	51	
50	159	159			8	54	159	37	-7	14	32	41	-36	-7	3	50	198	181	-7	9	32	123	120	
51	103	103			8	55	103	1	-7	14	33	108	113	-7	3	51	10	16	-7	9	33	40	25	
52	207	207			8	56	207	26	-7	14	34	26	-13	-7	3	52	13	-5	-7	9	34	9	-21	
53	65	65			8	57	65	74	-7	14	35	147	145	-7	3	53	95	-83	-7	9	35	109	-107	
54	58	58			8	58	58	1	-7	14	36	109	108	-7	3	54	101	-99	-7	9	36	54	-50	
55	219	219			8	59	219	195	-7	14	37	345	-346	-7	3	55	75	75	-7	9	37	143	137	
56	159	159			8	60	159	191	-7	14	38	150	-158	-7	3	56	92	85	-7	9	38	143	137	
57	103	103			8	61	103	141	-7	14	39	496	-516	-7	3	57	64	-63	-7	9	39	202	-202	
58	207	207			8	62	207	127	-7	14	40	152	160	-7	3	58	55	55	-7	9	40	129	130	
59	65	65			8	63	65	50	-7	14	41	498	-510	-7	3	59	22	18	-7	9	41	117	114	
60	58	58			8	64	58	142	-7	14	42	164	-165	-7	3	60	242	-242	-7	9	42	72	71	
61	219	219			8	65	219	87	-7	14	43	266	278	-7	3	61	21	19	-7	9	43	8	7	

OBSERVED AND CALCULATED STRUCTURE FACTORS FOR (PT3S2(P(CH3)2(C6H5)1)6) (R(C2H5)4)2

H	K	L	FO	FC	H	K	L	FO	FC	H	K	L	FO	FC	H	K	L	FO	FC	H	K	L	FO	FC
7	13	8	77	-73	4	2	29	18	-6	8	5	108	109	-6	12	13	49	47	-5	3	9	29	36	
7	13	33	33	-25	4	3	179	-178	-6	8	6	36	-25	-6	12	14	26	-32	-5	3	11	59	-30	
7	13	10	44	48	4	4	524	319	-6	8	8	271	-266	-6	12	15	150	-150	-5	3	12	59	-57	
7	13	11	20	13	4	5	84	76	-6	8	8	79	78	-6	12	16	40	56	-5	3	13	277	272	
7	13	12	26	18	4	6	453	-453	-6	8	9	262	257	-6	14	1	31	-20	-5	3	13	82	82	
7	13	13	73	-68	4	4	111	115	-6	8	10	131	-125	-6	14	2	226	-235	-5	3	14	29	-22	
7	13	14	71	64	4	8	435	451	-6	8	10	170	-170	-6	14	3	44	-44	-5	3	15	15	-11	
7	13	15	81	-80	4	4	234	224	-6	8	12	95	86	-6	14	4	110	116	-5	3	16	133	-132	
7	13	16	18	16	4	4	501	521	-6	8	13	61	55	-6	14	5	90	90	-5	3	17	115	-116	
7	13	17	76	73	4	10	176	178	-6	8	14	140	-138	-6	14	6	23	19	-5	3	18	33	36	
7	13	18	83	77	4	12	309	310	-6	8	15	119	120	-6	14	7	122	-114	-5	3	19	101	101	
6	6	4	88	88	4	13	159	162	-6	8	16	167	169	-6	14	8	84	-81	-5	3	20	45	43	
6	6	5	22	22	4	14	116	-107	-6	8	17	160	-154	-6	14	9	113	110	-5	3	21	1	3	
6	6	6	14	16	4	15	212	-214	-6	8	18	262	-258	-6	14	10	62	50	-5	3	22	147	-148	
6	6	7	44	44	4	16	120	122	-6	8	19	108	106	-6	14	11	95	-94	-5	3	23	44	44	
6	6	8	20	20	4	17	220	122	-6	8	20	154	155	-6	14	12	39	27	-5	3	24	224	223	
6	6	9	11	14	4	18	22	15	-6	8	21	13	-18	-6	14	1	1	1	-5	3	25	289	285	
6	6	10	16	14	4	19	94	40	-6	10	2	38	-31	-6	14	2	243	-320	-5	3	26	269	-280	
6	6	11	55	55	4	20	46	40	-6	10	3	138	138	-6	14	3	332	227	-5	3	27	235	-222	
6	6	12	20	20	4	21	29	34	-6	10	4	37	-33	-6	14	4	227	235	-5	3	28	457	421	
6	6	13	77	77	4	22	167	-168	-6	10	5	67	57	-6	14	5	35	50	-5	3	29	10	-31	
6	6	14	61	61	4	23	1	-6	-6	10	6	116	103	-6	14	6	64	54	-5	3	30	299	-296	
6	6	15	29	30	6	6	300	270	-6	10	7	273	-265	-6	14	7	306	-310	-5	3	31	304	292	
6	6	16	49	45	6	7	454	418	-6	10	8	103	96	-6	14	8	333	-248	-5	3	32	303	302	
6	6	17	88	88	6	8	183	170	-6	10	9	289	280	-6	14	9	412	422	-5	3	33	379	-377	
6	6	18	15	15	6	9	285	266	-6	10	10	72	73	-6	14	10	198	204	-5	3	34	235	-230	
6	6	19	72	77	6	10	101	-93	-6	10	11	229	-218	-6	14	11	166	-171	-5	3	35	235	-231	
6	6	20	108	111	6	11	147	-142	-6	10	12	103	-100	-6	14	12	19	-17	-5	3	36	239	233	
6	6	21	177	177	6	12	228	220	-6	10	13	148	144	-6	14	13	39	-38	-5	3	37	49	49	
6	6	22	278	278	6	13	43	42	-6	10	14	38	37	-6	14	14	232	-231	-5	3	38	297	-298	
6	6	23	44	44	6	14	183	-165	-6	10	15	34	-26	-6	14	15	272	281	-5	3	39	229	-223	
6	6	24	55	55	6	15	13	-7	-6	10	16	47	-41	-6	14	16	269	258	-5	3	40	192	192	
6	6	25	18	18	6	16	63	66	-6	10	17	107	-108	-6	14	17	207	-211	-5	3	41	278	276	
6	6	26	117	117	6	17	115	114	-6	10	18	26	24	-6	14	18	228	226	-5	3	42	115	-117	
6	6	27	49	45	6	18	355	-356	-6	10	19	132	133	-6	14	19	69	71	-5	3	43	174	-182	
6	6	28	51	51	6	19	85	89	-6	12	2	288	291	-6	14	20	139	142	-5	3	44	125	124	
6	6	29	14	14	6	20	341	343	-6	12	3	72	76	-6	14	21	28	-27	-5	3	45	61	58	
6	6	30	38	40	6	21	184	182	-6	12	4	123	-124	-6	14	22	72	-68	-5	3	46	173	-170	
6	6	31	20	20	6	22	284	286	-6	12	5	50	43	-6	14	23	50	-48	-5	3	47	64	65	
6	6	32	34	35	6	23	217	-215	-6	12	6	26	26	-6	14	24	20	-16	-5	3	48	25	11	
6	6	33	16	16	6	24	37	40	-6	12	7	102	102	-6	14	25	39	-43	-5	3	49	470	-465	
6	6	34	13	13	6	25	113	111	-6	12	8	61	62	-6	14	26	58	57	-5	3	50	87	-84	
6	6	35	100	100	6	26	222	222	-6	12	9	68	68	-6	14	27	21	-19	-5	3	51	301	284	
6	6	36	65	65	6	27	222	222	-6	12	10	62	62	-6	14	28	112	109	-5	3	52	46	-43	
6	6	37	72	72	6	28	118	122	-6	12	11	46	43	-6	14	29	393	-398	-5	3	53	76	-81	
6	6	38	2	2	6	29	169	160	-6	12	12	11	11	-6	14	30	135	-150	-5	3	54	105	-97	
6	6	39	1	1	6	30	169	160	-6	12	13	11	11	-6	14	31	705	710	-5	3	55	48	-44	
6	6	40	1	1	6	31	169	160	-6	12	14	11	11	-6	14	32	103	103	-5	3	56	103	103	

OBSERVED AND CALCULATED STRUCTURE FACTORS FOR (PT3S2(P(CH3)2(C6H5)1)6) (R(C2H5)4)2

H	K	L	FO	FC	H	K	L	FO	FC	H	K	L	FO	FC	H	K	L	FO	FC	H	K	L	FO	FC
1	1	1	26	19	11	16	87	87	-4	6	8	33	-32	-4	10	11	35	-43						
1	1	1	109	104	11	17	167	162	-4	6	9	147	-144	-4	10	12	177	185						
1	1	1	105	111	11	18	145	84	-4	6	10	102	107	-4	10	13	58	52						
1	1	1	400	227	11	1	145	146	-4	6	11	108	102	-4	10	14	29	-23						
1	1	1	250	242	11	2	238	249	-4	6	12	184	179	-4	10	15	87	-84						
1	1	1	69	75	11	3	106	116	-4	6	13	9	-25	-4	10	16	103	-104						
1	1	1	58	55	11	4	46	55	-4	6	14	314	-310	-4	10	17	15	10						
1	1	1	13	9	11	5	68	72	-4	6	15	156	-149	-4	10	18	91	91						
1	1	1	7	7	11	6	67	59	-4	6	16	364	367	-4	10	19	33	-25						
1	1	1	18	40	11	7	18	24	-4	6	17	216	217	-4	10	20	30	33						
1	1	1	20	40	11	8	65	63	-4	6	18	313	-318	-4	12	1	335	333						
1	1	1	2	1	11	9	60	57	-4	6	19	117	-120	-4	12	2	76	-80						
1	1	1	2	7	11	10	42	41	-4	6	20	200	200	-4	12	3	135	-137						
1	1	1	2	3	11	11	1	1	-4	6	21	106	-108	-4	12	4	58	62						
1	1	1	2	3	11	12	14	5	-4	6	22	94	-98	-4	12	5	44	-55						
1	1	1	2	3	11	13	55	55	-4	6	23	113	118	-4	12	6	1	1						
1	1	1	2	3	11	14	78	88	-4	6	24	169	171	-4	12	7	137	147						
1	1	1	2	3	11	15	106	108	-4	6	25	264	228	-4	12	8	11	28						
1	1	1	2	3	11	1	123	107	-4	8	2	17	-12	-4	12	9	103	-110						
1	1	1	2	3	11	2	99	107	-4	8	3	155	-146	-4	12	10	69	-78						
1	1	1	2	3	11	3	18	21	-4	8	4	271	268	-4	12	11	48	53						
1	1	1	2	3	11	4	126	129	-4	8	5	113	109	-4	12	12	62	64						
1	1	1	2	3	11	5	103	106	-4	8	6	519	-486	-4	12	13	45	83						
1	1	1	2	3	11	6	65	70	-4	8	7	65	73	-4	12	14	55	-57						
1	1	1	2	3	11	7	161	165	-4	8	8	785	762	-4	12	15	139	-142						
1	1	1	2	3	11	8	45	46	-4	8	9	334	-328	-4	12	16	46	67						
1	1	1	2	3	11	9	146	150	-4	8	10	465	-461	-4	12	17	187	197						
1	1	1	2	3	11	10	43	47	-4	8	11	151	147	-4	14	1	54	-41						
1	1	1	2	3	11	1	331	331	-4	8	12	281	275	-4	14	2	216	-232						
1	1	1	2	3	11	2	325	349	-4	8	13	88	86	-4	14	3	17	-23						
1	1	1	2	3	11	3	319	381	-4	8	14	102	-106	-4	14	4	79	90						
1	1	1	2	3	11	4	292	313	-4	8	15	172	-170	-4	14	5	86	82						
1	1	1	2	3	11	5	300	306	-4	8	16	82	-82	-4	14	6	1	16						
1	1	1	2	3	11	6	64	66	-4	8	17	151	148	-4	14	7	102	-102						
1	1	1	2	3	11	7	367	357	-4	8	18	47	47	-4	14	8	53	-55						
1	1	1	2	3	11	8	483	456	-4	8	19	69	-61	-4	14	9	86	89						
1	1	1	2	3	11	9	318	301	-4	8	20	45	46	-4	14	10	59	49						
1	1	1	2	3	11	10	102	96	-4	8	21	6	10	-4	14	11	95	-99						
1	1	1	2	3	11	1	74	71	-4	8	22	176	-168	-4	14	12	32	33						
1	1	1	2	3	11	2	1	29	-4	8	23	1	22	-4	14	13	44	47						
1	1	1	2	3	11	3	594	545	-4	8	24	232	222	-4	14	14	113	-117						
1	1	1	2	3	11	4	109	121	-4	8	25	262	228	-4	14	15	74	-78						
1	1	1	2	3	11	5	249	237	-4	8	26	526	-512	-4	14	16	13	-11						
1	1	1	2	3	11	6	64	66	-4	8	27	223	207	-4	14	17	37	16						
1	1	1	2	3	11	7	44	35	-4	8	28	397	385	-4	14	18	95	100						
1	1	1	2	3	11	8	321	291	-4	8	29	130	116	-4	14	19	59	60						
1	1	1	2	3	11	9	417	400	-4	8	30	126	123	-4	14	20	159	-155						
1	1	1	2	3	11	10	378	374	-4	8	31	206	187	-4	14	21	116	-117						

OBSERVED AND CALCULATED STRUCTURE FACTORS FOR (PT3S2(P(CH3)2(C6H5))6) (B(C2H5)4)2

H	K	L	FO	FC	H	K	L	FO	FC	H	K	L	FO	FC	H	K	L	FO	FC	
1	1	1	141	-135	24	270	264	7	23	58	-58	13	8	71	-71	2	2	16	144	148
1	1	2	609	-616	25	46	64	9	9	189	-180	13	9	26	-32	2	2	17	316	-297
1	1	3	270	-274	25	415	413	9	1	37	-28	13	10	76	75	2	2	18	36	-42
1	1	4	442	444	25	370	358	9	3	42	40	13	11	61	58	2	2	19	215	201
1	1	5	60	46	25	343	327	9	4	270	87	13	12	27	37	2	2	20	141	136
1	1	6	58	54	25	270	274	9	5	175	172	13	13	17	25	2	2	21	39	-37
1	1	7	375	359	25	75	60	9	6	229	-242	13	14	105	-118	2	2	22	163	-164
1	1	8	119	103	25	257	261	9	7	287	-300	13	15	114	-113	2	2	23	113	-123
1	1	9	346	355	25	447	436	9	8	272	-286	13	16	198	-203	2	2	24	173	176
1	1	10	9	8	25	215	219	9	9	309	-321	15	1	112	-110	2	2	25	169	170
1	1	11	181	172	10	296	288	9	10	254	-264	15	2	91	-89	4	4	1	71	96
1	1	12	104	105	10	202	191	9	11	240	-248	15	3	1	16	4	4	2	67	79
1	1	13	559	556	11	108	114	9	12	170	179	15	4	99	103	4	4	3	59	-57
1	1	14	333	339	11	1	10	9	13	62	61	15	5	90	88	4	4	4	144	149
1	1	15	333	330	11	1	10	9	14	78	-74	15	6	31	-30	4	4	5	74	57
1	1	16	333	332	11	113	105	9	15	103	99	15	7	157	-174	4	4	6	541	-517
1	1	17	333	338	11	248	249	9	16	43	43	15	8	48	44	4	4	7	203	195
1	1	18	333	335	11	102	104	9	17	117	-111	15	9	185	188	4	4	8	628	605
1	1	19	333	338	11	310	306	9	18	7	8	15	10	24	-38	4	4	9	135	-139
1	1	20	228	228	11	117	120	9	19	75	74	15	11	115	-122	4	4	10	469	-461
1	1	21	57	55	11	215	214	9	20	59	52	15	12	55	58	4	4	11	51	48
1	1	22	22	22	11	116	123	9	21	10	16	15	13	675	-700	4	4	12	186	185
1	1	23	12	14	11	332	335	11	1	304	301	15	14	116	114	4	4	13	37	-32
1	1	24	1	1	11	87	90	11	2	41	43	15	15	183	-165	4	4	14	16	-18
1	1	25	143	144	11	90	86	11	3	180	-189	15	16	60	-58	4	4	15	69	-71
1	1	26	134	133	11	66	64	11	4	89	93	15	17	77	73	4	4	16	126	-121
1	1	27	33	33	11	61	59	11	5	31	-13	15	18	154	160	4	4	17	253	249
1	1	28	183	182	11	542	538	11	6	236	-246	15	19	401	-373	4	4	18	98	100
1	1	29	36	36	11	37	34	11	7	98	103	15	20	580	-547	4	4	19	194	-190
1	1	30	11	11	11	275	273	11	8	262	-282	15	21	599	-588	4	4	20	17	23
1	1	31	506	509	11	26	16	11	9	115	-123	15	22	360	351	4	4	21	27	30
1	1	32	43	43	11	10	9	11	10	187	-197	15	23	43	-48	4	4	22	120	-123
1	1	33	702	708	11	115	115	11	11	45	50	15	24	68	-62	4	4	23	76	67
1	1	34	146	138	11	226	232	11	12	146	150	15	1	810	-738	4	4	24	183	184
1	1	35	557	554	11	174	181	11	13	87	90	15	2	263	-242	4	4	25	321	302
1	1	36	165	164	11	101	102	11	14	22	33	15	3	315	316	4	4	26	459	-463
1	1	37	457	441	11	122	123	11	15	108	115	15	4	304	303	4	4	27	245	-245
1	1	38	66	66	11	51	55	11	16	42	44	15	5	251	251	4	4	28	185	187
1	1	39	50	52	11	52	56	11	17	146	152	15	6	526	-493	4	4	29	53	50
1	1	40	89	89	11	257	260	11	18	21	23	15	7	366	-348	4	4	30	22	28
1	1	41	100	107	11	21	24	11	19	124	-126	15	8	252	257	4	4	31	167	164
1	1	42	100	97	11	392	404	11	20	173	163	15	9	415	-390	4	4	32	211	-211
1	1	43	111	107	11	1	88	11	21	223	-222	15	10	394	360	4	4	33	202	-203
1	1	44	64	67	11	316	318	11	22	95	93	15	11	259	-255	4	4	34	48	56
1	1	45	35	35	11	18	7	11	23	81	85	15	12	367	357	4	4	35	124	123
1	1	46	10	10	11	194	192	11	24	33	33	15	13	204	-195	4	4	36	163	172
1	1	47	143	136	11	1	14	11	25	24	28	15	14	204	-195	4	4	37	123	134
1	1	48	1	1	11	51	52	11	26	16	17	15	15	241	230	4	4	38	130	-131

OBSERVED AND CALCULATED STRUCTURE FACTORS FOR (PT3S2(P(CH3)2(C6H5))6) (R(C2H5)4)2

H	K	L	FO	FC	H	K	L	FO	FC	H	K	L	FO	FC	H	K	L	FO	FC						
1	1	1	243	-254	10	18	23	23	-1	1	4	331	301	-1	5	2	54	-56	-1	9	3	154	140		
1	1	1	243	-254	10	19	13	-21	-1	1	5	441	409	-1	5	3	178	-180	-1	9	4	176	185		
1	1	1	243	-254	10	20	44	41	-1	1	6	370	-319	-1	5	4	69	60	-1	9	5	41	35		
1	1	1	243	-254	10	21	290	297	-1	1	7	326	-304	-1	5	5	64	-70	-1	9	6	273	-292		
1	1	1	243	-254	10	22	147	143	-1	1	8	80	85	-1	5	6	76	-74	-1	9	7	258	-275		
1	1	1	243	-254	10	23	190	188	-1	1	9	382	330	-1	5	7	365	364	-1	9	8	296	320		
1	1	1	243	-254	10	24	155	166	-1	1	10	134	-119	-1	5	8	94	96	-1	9	9	369	392		
1	1	1	243	-254	10	25	34	43	-1	1	11	133	-131	-1	5	9	358	-366	-1	9	10	275	-296		
1	1	1	243	-254	10	26	128	137	-1	1	12	239	208	-1	5	10	278	-280	-1	9	11	233	-249		
1	1	1	243	-254	10	27	178	190	-1	1	13	1	15	378	-344	-1	5	11	188	201	-1	9	12	176	187
1	1	1	243	-254	10	28	65	59	-1	1	14	92	103	-1	5	12	98	98	-1	9	13	32	-20		
1	1	1	243	-254	10	29	217	233	-1	1	15	424	403	-1	5	13	74	69	-1	9	14	121	-127		
1	1	1	243	-254	10	30	86	92	-1	1	16	266	-272	-1	5	14	224	20	-1	9	15	147	150		
1	1	1	243	-254	10	31	118	125	-1	1	17	432	-420	-1	5	15	239	-234	-1	9	16	45	52		
1	1	1	243	-254	10	32	66	74	-1	1	18	224	241	-1	5	16	37	36	-1	9	17	137	-141		
1	1	1	243	-254	10	33	104	109	-1	1	19	312	307	-1	5	17	333	324	-1	9	18	54	58		
1	1	1	243	-254	10	34	160	169	-1	1	20	1	17	263	-254	-1	5	18	58	-68	-1	9	19	54	58
1	1	1	243	-254	10	35	116	125	-1	1	21	138	-136	-1	5	19	263	-254	-1	9	20	37	46		
1	1	1	243	-254	10	36	178	182	-1	1	22	172	-171	-1	5	20	80	79	-1	9	21	29	20		
1	1	1	243	-254	10	37	89	103	-1	1	23	1	27	79	72	-1	5	21	79	72	-1	11	1	194	194
1	1	1	243	-254	10	38	27	24	-1	1	24	141	148	-1	5	22	38	-43	-1	11	2	67	-71		
1	1	1	243	-254	10	39	221	225	-1	1	25	255	-257	-1	5	23	84	83	-1	11	3	127	-126		
1	1	1	243	-254	10	40	21	21	-1	1	26	292	299	-1	5	24	44	31	-1	11	4	148	157		
1	1	1	243	-254	10	41	82	86	-1	1	27	21	21	-1	7	1	57	-60	-1	11	5	61	62		
1	1	1	243	-254	10	42	37	28	-1	1	28	147	151	-1	7	2	74	-74	-1	11	6	278	-290		
1	1	1	243	-254	10	43	118	126	-1	1	29	23	22	-1	7	3	189	189	-1	11	7	97	103		
1	1	1	243	-254	10	44	84	83	-1	1	30	635	-632	-1	7	4	204	200	-1	11	8	384	420		
1	1	1	243	-254	10	45	119	125	-1	1	31	77	78	-1	7	5	48	48	-1	11	9	194	-206		
1	1	1	243	-254	10	46	119	125	-1	1	32	520	497	-1	7	6	48	48	-1	11	10	412	-442		
1	1	1	243	-254	10	47	78	77	-1	1	33	208	217	-1	7	7	180	-186	-1	11	11	70	63		
1	1	1	243	-254	10	48	86	91	-1	1	34	431	-418	-1	7	8	230	-240	-1	11	12	172	180		
1	1	1	243	-254	10	49	19	19	-1	1	35	126	-123	-1	7	9	25	30	-1	11	13	71	78		
1	1	1	243	-254	10	50	49	42	-1	1	36	312	292	-1	7	10	186	193	-1	11	14	23	-29		
1	1	1	243	-254	10	51	125	131	-1	1	37	95	-87	-1	7	11	49	-52	-1	11	15	122	-130		
1	1	1	243	-254	10	52	74	71	-1	1	38	158	145	-1	7	12	14	-10	-1	11	16	26	9		
1	1	1	243	-254	10	53	11	18	-1	1	39	95	89	-1	7	13	136	135	-1	11	17	129	136		
1	1	1	243	-254	10	54	5	2	-1	1	40	109	100	-1	7	14	223	-232	-1	11	18	23	-34		
1	1	1	243	-254	10	55	1	15	-1	1	41	53	52	-1	7	15	86	-88	-1	11	19	73	-80		
1	1	1	243	-254	10	56	6	13	-1	1	42	180	169	-1	7	16	308	308	-1	11	20	153	150		
1	1	1	243	-254	10	57	97	98	-1	1	43	22	29	-1	7	17	29	-23	-1	11	21	276	-277		
1	1	1	243	-254	10	58	103	98	-1	1	44	36	29	-1	7	18	266	-268	-1	11	22	125	-127		
1	1	1	243	-254	10	59	146	148	-1	1	45	42	38	-1	7	19	28	43	-1	11	23	186	191		
1	1	1	243	-254	10	60	152	148	-1	1	46	176	-166	-1	7	20	128	122	-1	11	24	16	-6		
1	1	1	243	-254	10	61	167	170	-1	1	47	1	-24	-1	7	21	26	35	-1	11	25	50	-53		
1	1	1	243	-254	10	62	578	572	-1	1	48	262	262	-1	7	22	23	-24	-1	11	26	20	11		
1	1	1	243	-254	10	63	756	728	-1	1	49	12	50	-1	7	23	86	-82	-1	11	27	93	-96		
1	1	1	243	-254	10	64	157	139	-1	1	50	446	440	-1	7	24	226	-218	-1	11	28	38	-26		
1	1	1	243	-254	10	65	157	139	-1	1	51	446	440	-1	9	25	111	-114	-1	13	29	61	61		

OBSERVED AND CALCULATED STRUCTURE FACTORS FOR (PT3S2(P(CH3)2(C6H5))6) (R(C2H5)4)2 PAGE 10

H	K	L	FO	FC	H	K	L	FO	FC	H	K	L	FO	FC	H	K	L	FO	FC	H	K	L	FO	FC	
1	1	1	99	100	14	6	7	33	36	3	7	5	40	-38	3	11	9	54	-58	4	4	0	18	242	-240
1	1	1	134	129	14	7	8	93	93	3	7	6	52	60	3	11	10	178	-187	4	4	0	14	280	-279
1	1	1	17	14	14	8	9	91	94	3	7	7	90	-99	3	11	11	15	18	4	4	0	16	353	351
1	1	1	143	-132	14	9	10	89	91	3	7	8	84	-91	3	11	12	103	106	4	4	0	17	483	495
1	1	1	16	-10	14	10	11	41	42	3	7	9	139	144	3	11	13	19	29	4	4	0	18	613	-606
1	1	1	46	44	14	11	12	78	-81	3	7	10	19	29	3	11	14	25	-33	4	4	0	19	771	-767
1	1	1	16	13	14	12	13	44	43	3	7	11	86	-89	3	11	15	119	-124	4	4	0	20	884	-888
1	1	1	87	96	14	13	14	42	46	3	7	12	114	117	3	11	16	93	-93	4	4	0	21	997	-999
1	1	1	305	-333	16	14	15	117	-118	3	7	13	16	-23	3	11	17	176	171	4	4	0	22	1109	-1110
1	1	1	123	-129	16	15	16	34	31	3	7	14	248	-244	3	11	18	90	88	4	4	0	23	1221	-1222
1	1	1	380	408	16	16	17	71	-70	3	7	15	41	37	3	11	19	285	292	4	4	0	24	1333	-1334
1	1	1	64	63	16	17	18	31	25	3	7	16	331	324	3	11	20	187	182	4	4	0	25	1445	-1446
1	1	1	301	-319	16	18	19	1	11	3	7	17	17	30	3	11	21	222	-230	4	4	0	26	1557	-1558
1	1	1	78	86	16	19	20	64	68	3	7	18	353	-343	3	11	22	105	-102	4	4	0	27	1669	-1669
1	1	1	154	167	16	20	21	81	87	3	7	19	1	-16	3	11	23	63	60	4	4	0	28	1781	-1781
1	1	1	48	50	16	21	22	109	-107	3	7	20	201	197	3	11	24	18	20	4	4	0	29	1893	-1893
1	1	1	21	-12	16	22	23	133	-142	3	7	21	1	-8	3	11	25	30	30	4	4	0	30	2005	-2005
1	1	1	1	-12	16	23	24	143	142	3	7	22	59	-53	3	11	26	63	60	4	4	0	31	2117	-2117
1	1	1	1	-12	16	24	25	324	-321	3	7	23	39	-14	3	11	27	18	20	4	4	0	32	2229	-2229
1	1	1	88	99	11	25	26	371	-389	3	7	24	207	-206	3	11	28	71	-66	4	4	0	33	2341	-2341
1	1	1	20	23	11	26	27	273	-295	3	7	25	156	-140	3	11	29	32	-45	4	4	0	34	2453	-2453
1	1	1	105	106	11	27	28	398	417	3	7	26	25	-140	3	11	30	46	47	4	4	0	35	2565	-2565
1	1	1	37	44	11	28	29	92	98	3	7	27	25	-140	3	11	31	33	-26	4	4	0	36	2677	-2677
1	1	1	1	1	11	29	30	33	39	3	7	28	122	129	3	11	32	13	14	4	4	0	37	2789	-2789
1	1	1	169	165	11	30	31	136	-121	3	7	29	193	203	3	11	33	66	65	4	4	0	38	2901	-2901
1	1	1	298	305	11	31	32	315	-316	3	7	30	173	-185	3	11	34	76	83	4	4	0	39	3013	-3013
1	1	1	183	-186	11	32	33	149	-153	3	7	31	235	-243	3	11	35	84	-88	4	4	0	40	3125	-3125
1	1	1	163	-165	11	33	34	431	438	3	7	32	264	282	3	11	36	87	87	4	4	0	41	3237	-3237
1	1	1	98	101	11	34	35	123	114	3	7	33	237	251	3	11	37	126	-131	4	4	0	42	3349	-3349
1	1	1	23	15	11	35	36	238	-241	3	7	34	203	-211	3	11	38	133	-134	4	4	0	43	3461	-3461
1	1	1	94	-103	11	36	37	79	79	3	7	35	145	-148	3	11	39	33	33	4	4	0	44	3573	-3573
1	1	1	143	156	11	37	38	61	-56	3	7	36	123	125	3	11	40	98	95	4	4	0	45	3685	-3685
1	1	1	107	115	11	38	39	236	-220	3	7	37	79	73	3	11	41	107	105	4	4	0	46	3797	-3797
1	1	1	127	-133	11	39	40	234	-231	3	7	38	41	-36	3	11	42	62	-67	4	4	0	47	3909	-3909
1	1	1	35	36	11	40	41	260	231	3	7	39	44	46	3	11	43	159	-168	4	4	0	48	4021	-4021
1	1	1	84	87	11	41	42	196	-184	3	7	40	1	5	3	11	44	16	27	4	4	0	49	4133	-4133
1	1	1	40	37	11	42	43	203	-199	3	7	41	161	-166	3	11	45	154	160	4	4	0	50	4245	-4245
1	1	1	63	66	11	43	44	196	61	3	7	42	14	-14	3	11	46	35	-40	4	4	0	51	4357	-4357
1	1	1	75	77	11	44	45	106	103	3	7	43	107	107	3	11	47	105	-110	4	4	0	52	4469	-4469
1	1	1	179	-189	11	45	46	30	-34	3	7	44	27	21	4	4	0	0	0	4	4	0	53	4581	-4581
1	1	1	87	92	11	46	47	45	-42	3	7	45	140	-133	4	4	0	0	0	4	4	0	54	4693	-4693
1	1	1	179	187	11	47	48	45	-41	3	7	46	309	308	4	4	0	0	0	4	4	0	55	4805	-4805
1	1	1	263	271	11	48	49	48	-41	3	7	47	87	86	4	4	0	0	0	4	4	0	56	4917	-4917
1	1	1	40	-38	11	49	50	1	12	3	7	48	130	-132	4	4	0	0	0	4	4	0	57	5029	-5029
1	1	1	220	-214	11	50	51	41	-39	3	7	49	101	107	4	4	0	0	0	4	4	0	58	5141	-5141
1	1	1	220	211	11	51	52	457	-402	3	7	50	21	-17	4	4	0	0	0	4	4	0	59	5253	-5253
1	1	1	28	30	11	52	53	30	27	3	7	51	203	-211	4	4	0	0	0	4	4	0	60	5365	-5365
1	1	1	103	101	11	53	54	44	44	3	7	52	63	63	4	4	0	0	0	4	4	0	61	5477	-5477
1	1	1	87	87	11	54	55	222	197	3	7	53	199	195	4	4	0	0	0	4	4	0	62	5589	-5589

OBSERVED AND CALCULATED STRUCTURE FACTORS FOR (PT3S2(P(CH3)2(C6H5)1)6) (R(C2H5)4)2

H	K	L	FO	FC	H	K	L	FO	FC	H	K	L	FO	FC	H	K	L	FO	FC	H	K	L	FO	FC
4	4	4	86	87	4	4	22	158	-148	4	10	4	94	91	4	16	3	33	24	5	5	21	24	10
4	4	4	33	45	4	4	0	567	-164	4	4	5	107	-113	4	16	3	91	23	5	5	22	115	116
4	4	4	39	16	4	4	6	350	349	4	4	10	290	-306	4	16	5	41	48	5	5	0	128	127
4	4	4	12	55	4	4	6	609	-308	4	4	10	96	-99	4	16	6	140	-135	5	5	1	393	394
4	4	4	77	84	4	4	6	156	-140	4	4	10	256	-267	4	16	6	440	402	5	5	2	128	127
4	4	4	55	163	4	4	3	268	292	4	4	10	89	-88	4	16	1	153	-145	5	5	3	193	178
4	4	4	11	115	4	4	4	166	-164	4	4	10	190	-190	4	16	1	320	-310	5	5	4	365	356
4	4	4	17	174	4	4	5	134	-137	4	4	10	84	-92	4	16	1	297	-320	5	5	5	1	12
4	4	4	44	46	4	4	6	148	-148	4	4	10	130	-136	4	16	1	320	59	5	5	6	318	-327
4	4	4	11	200	4	4	6	20	-20	4	4	10	83	-85	4	16	1	47	-23	5	5	7	288	285
4	4	4	33	37	4	4	6	163	-167	4	4	10	14	-14	4	16	1	70	-69	5	5	8	228	232
4	4	4	11	115	4	4	6	15	-15	4	4	10	15	-12	4	16	1	314	-326	5	5	9	280	-281
4	4	4	11	115	4	4	6	63	-63	4	4	10	112	-107	4	16	7	109	-107	5	5	10	180	-181
4	4	4	11	115	4	4	6	207	-210	4	4	10	17	-16	4	16	9	328	-349	5	5	11	144	-148
4	4	4	11	115	4	4	6	16	-16	4	4	10	18	-20	4	16	1	197	-113	5	5	12	260	266
4	4	4	11	115	4	4	6	313	-314	4	4	12	86	-86	4	16	1	197	-203	5	5	13	46	49
4	4	4	11	115	4	4	6	108	-108	4	4	12	1	-1	4	16	1	57	-58	5	5	14	189	-188
4	4	4	11	115	4	4	6	315	-317	4	4	12	78	-74	4	16	1	64	-60	5	5	15	209	-208
4	4	4	11	115	4	4	6	164	-173	4	4	12	163	-160	4	16	1	192	-190	5	5	16	125	120
4	4	4	11	115	4	4	6	252	-248	4	4	12	50	-55	4	16	1	192	-197	5	5	17	228	224
4	4	4	11	115	4	4	6	178	-174	4	4	12	42	-44	4	16	1	252	-249	5	5	18	98	97
4	4	4	11	115	4	4	6	222	-221	4	4	12	8	-8	4	16	1	136	-128	5	5	19	170	-169
4	4	4	11	115	4	4	6	8	-8	4	4	12	8	-8	4	16	1	169	-165	5	5	20	95	93
4	4	4	11	115	4	4	6	479	-465	4	4	12	59	-59	4	16	1	66	-64	5	5	21	31	29
4	4	4	11	115	4	4	6	209	-200	4	4	12	57	-64	4	16	1	123	-125	5	5	7	606	613
4	4	4	11	115	4	4	6	341	-333	4	4	12	44	-38	4	16	1	42	-27	5	5	8	44	32
4	4	4	11	115	4	4	6	93	-94	4	4	12	50	-53	4	16	1	42	-41	5	5	9	406	-422
4	4	4	11	115	4	4	6	166	-173	4	4	12	19	-11	4	16	3	123	-114	5	5	10	104	96
4	4	4	11	115	4	4	6	57	-58	4	4	12	39	-44	4	16	1	90	-93	5	5	11	274	276
4	4	4	11	115	4	4	6	277	-286	4	4	12	14	-14	4	16	3	66	-59	5	5	12	59	55
4	4	4	11	115	4	4	6	107	-113	4	4	12	17	-21	4	16	1	1	-4	5	5	13	10	-16
4	4	4	11	115	4	4	6	257	-258	4	4	12	41	-40	4	16	3	177	-192	5	5	14	113	-111
4	4	4	11	115	4	4	6	133	-133	4	4	12	266	-276	4	16	3	413	-433	5	5	15	79	-74
4	4	4	11	115	4	4	6	152	-158	4	4	12	62	-63	4	16	3	147	-157	5	5	16	134	-137
4	4	4	11	115	4	4	6	90	-91	4	4	12	71	-75	4	16	7	617	-624	5	5	17	13	-19
4	4	4	11	115	4	4	6	183	-205	4	4	14	80	-88	4	16	7	115	-126	5	5	18	90	-87
4	4	4	11	115	4	4	6	123	-104	4	4	14	128	-123	4	16	9	496	-506	5	5	19	26	-29
4	4	4	11	115	4	4	6	105	-104	4	4	14	35	-38	4	16	11	56	-59	5	5	20	241	-236
4	4	4	11	115	4	4	6	190	-184	4	4	14	94	-87	4	16	12	216	-220	5	5	21	30	30
4	4	4	11	115	4	4	6	153	-155	4	4	14	62	-66	4	16	13	71	-73	5	5	22	302	295
4	4	4	11	115	4	4	6	199	-192	4	4	14	92	-95	4	16	14	44	-48	5	5	23	17	-6
4	4	4	11	115	4	4	6	100	-97	4	4	14	54	-47	4	16	15	1	-16	5	5	24	275	-258
4	4	4	11	115	4	4	6	121	-115	4	4	14	71	-75	4	16	16	77	-71	5	5	25	1	1
4	4	4	11	115	4	4	6	293	-291	4	4	14	34	-38	4	16	17	54	-54	5	5	26	156	-151
4	4	4	11	115	4	4	6	29	-28	4	4	16	50	-50	4	16	18	25	-18	5	5	27	22	-18
4	4	4	11	115	4	4	6	109	-108	4	4	16	43	-43	4	16	19	27	-28	5	5	28	280	-267
4	4	4	11	115	4	4	6	105	-105	4	4	16	43	-43	4	16	20	27	-16	5	5	29	1	10

OBSERVED AND CALCULATED STRUCTURE FACTORS FOR (PT3S2(P(CH3)2(C6H5))6) (R(C2H5)4)2

H	K	L	FO	FC	H	K	L	FO	FC	H	K	L	FO	FC	H	K	L	FO	FC
9	3	25	-28		5	15	1	104	-101	6	4	7	158	159	6	8	12	83	84
9	4	91	87		5	15	1	111	-115	6	4	8	436	-446	6	8	13	23	22
9	5	14	211		5	15	3	111	-115	6	4	9	121	-123	6	8	14	160	-157
9	6	188	193		5	15	5	96	-98	6	4	10	390	-397	6	8	15	114	115
9	7	238	252		5	15	7	111	-108	6	4	11	228	-223	6	8	16	158	-151
9	8	227	231		5	15	8	84	-76	6	4	12	189	-182	6	8	17	147	-139
9	9	198	206		5	15	8	145	-152	6	4	13	67	-63	6	8	18	123	-122
9	10	188	187		5	15	8	52	-52	6	4	14	24	-24	6	8	18	196	-193
9	11	145	141		5	15	0	36	-36	6	4	15	108	-106	6	8	10	9	4
9	12	131	134		5	15	0	41	-40	6	4	16	1	-20	6	8	10	131	134
9	13	56	52		5	15	0	19	-20	6	4	17	136	-135	6	8	10	70	-76
9	14	41	24		5	15	0	94	-112	6	4	18	68	-63	6	8	10	81	-81
9	15	76	81		5	15	0	24	-25	6	4	19	107	-107	6	8	10	51	-54
9	16	25	18		5	15	0	33	-33	6	4	20	35	-26	6	8	10	261	-260
9	17	142	138		5	15	0	66	-55	6	4	21	32	-20	6	8	10	49	-49
9	18	25	3		5	15	0	20	-20	6	6	6	45	-46	6	8	10	261	-258
11	1	174	177		5	15	0	116	-110	6	6	6	26	-26	6	8	10	77	-67
11	2	40	233		5	15	0	37	-37	6	6	6	41	-39	6	8	10	223	-227
11	3	75	72		5	15	0	16	-16	6	6	6	11	-10	6	8	10	45	-38
11	4	9	14		5	15	0	17	-15	6	6	6	25	-25	6	8	10	121	-119
11	5	56	55		5	15	1	35	-35	6	6	6	98	-96	6	8	10	21	-19
11	6	161	163		5	15	3	131	-125	6	6	6	78	-67	6	8	10	24	-35
11	7	51	57		5	15	4	166	-183	6	6	6	149	-146	6	8	10	16	-20
11	8	153	157		5	15	4	76	-90	6	6	6	83	-77	6	8	10	72	-65
11	9	51	56		5	15	5	189	-204	6	6	6	164	-164	6	8	10	114	-113
11	10	108	109		5	15	5	31	-33	6	6	6	22	-29	6	8	10	260	-253
11	11	19	14		5	15	8	55	-55	6	6	6	93	-90	6	8	10	107	-102
11	12	40	91		5	15	9	11	-33	6	6	6	72	-73	6	8	10	101	-100
11	13	37	33		5	15	9	168	-178	6	6	6	12	-13	6	8	10	81	-75
11	14	26	15		5	15	10	206	-216	6	6	6	147	-148	6	8	10	27	-27
11	15	99	92		5	15	10	17	-17	6	6	6	251	-242	6	8	10	46	-47
11	16	68	64		5	15	10	35	-34	6	6	6	144	-138	6	8	10	99	-93
11	17	99	97		5	15	10	110	-108	6	6	6	222	-213	6	8	10	32	-34
11	18	154	147		5	15	15	151	-159	6	6	6	72	-72	6	8	10	108	-116
11	19	191	190		5	15	16	49	-52	6	6	6	237	-225	6	8	10	62	-62
11	20	91	85		5	15	16	165	-164	6	6	6	138	-125	6	8	10	42	-45
11	21	40	41		5	15	18	33	-31	6	6	6	250	-242	6	8	10	63	54
11	22	54	59		5	15	19	130	-125	6	6	6	163	-163	6	8	10	41	-41
11	23	17	17		5	15	20	11	-6	6	6	93	-87	6	8	10	227	-222	
11	24	57	58		5	15	20	87	-88	6	6	6	129	-133	6	8	10	190	-191
11	25	8	18		5	15	20	260	-256	6	6	6	229	-228	6	8	10	53	-52
11	26	44	41		5	15	23	22	-22	6	6	6	251	-250	6	8	10	74	-71
11	27	15	11		5	15	23	161	-157	6	6	6	254	-250	6	8	10	73	-73
11	28	71	65		5	15	24	44	-45	6	6	6	348	-348	6	8	10	18	-18
11	29	109	109		5	15	25	377	-398	6	6	6	39	-30	6	8	10	102	-99

OBSERVED AND CALCULATED STRUCTURE FACTORS FOR (PT3S2(P(CH3)2(C6H5))16) (R(C2H5)4)2

H	K	L	FO	FC	H	K	L	FO	FC	H	K	L	FO	FC	H	K	L	FO	FC
7	7	7	48	-49	7	9	14	39	-47	8	6	14	87	-83	8	14	1	19	27
7	7	7	146	-152	7	9	15	107	100	8	6	15	137	-137	8	14	2	145	-145
7	7	7	207	215	7	9	16	4	7	8	6	16	159	-156	8	14	3	20	-15
7	7	7	180	174	7	11	0	40	-36	8	6	17	110	111	8	14	4	82	78
7	7	7	196	-193	7	11	1	179	175	8	6	18	200	199	8	14	5	408	431
7	7	7	143	-143	7	11	2	15	-6	8	6	19	183	-178	9	9	0	254	-265
7	7	7	71	68	7	11	3	103	-99	8	6	20	200	-204	9	9	1	408	431
7	7	7	69	64	7	11	4	80	68	8	6	21	183	-178	9	9	2	254	-265
7	7	7	45	49	7	11	5	34	15	8	6	22	200	-204	9	9	3	313	-330
7	7	7	27	-24	7	11	6	171	-173	8	6	23	149	139	9	9	4	209	228
7	7	7	143	-141	7	11	7	93	94	8	6	24	127	115	9	9	5	145	161
7	7	7	63	61	7	11	8	200	219	8	6	25	73	-67	9	9	6	137	-149
7	7	7	204	197	7	11	9	105	-101	8	6	26	200	-198	9	9	7	157	-149
7	7	7	75	-75	7	11	10	0	191	8	6	27	86	-75	9	9	8	33	34
7	7	7	130	-128	7	11	11	46	43	8	6	28	166	-166	9	9	9	120	119
7	7	7	43	43	7	11	12	93	89	8	6	29	137	-129	9	9	10	72	-73
7	7	7	29	-21	7	11	13	0	38	8	6	30	75	-74	9	9	11	88	-80
7	7	7	3	-3	7	11	14	2	20	8	6	31	22	23	9	9	12	112	114
7	7	7	36	-32	7	13	0	2	2	8	6	32	13	-3	9	9	13	1	6
7	7	7	182	160	7	13	1	15	5	8	6	33	61	-55	9	9	14	172	-180
7	7	7	47	51	7	13	2	189	-177	8	6	34	115	-118	9	9	15	93	92
7	7	7	23	18	7	13	3	80	109	8	6	35	200	-204	9	9	16	206	-212
7	7	7	55	-55	7	13	4	109	109	8	6	36	82	-81	9	9	17	129	-133
7	7	7	172	-162	7	13	5	14	17	8	6	37	49	-47	9	9	18	183	-186
7	7	7	45	36	7	13	6	23	3	8	6	38	26	-29	9	9	19	202	-206
7	7	7	116	109	7	13	7	113	113	8	6	39	49	-47	9	9	20	28	-30
7	7	7	52	-44	7	13	8	68	-63	8	6	40	25	-25	9	9	21	80	80
7	7	7	41	39	7	13	9	42	33	8	6	41	7	-19	9	9	22	18	36
7	7	7	42	47	7	13	10	26	23	8	6	42	21	-27	9	9	23	145	157
7	7	7	183	-172	7	15	0	106	100	8	6	43	58	-53	9	9	24	14	10
7	7	7	6	-1	7	15	1	62	52	8	6	44	1	-1	9	9	25	282	-310
7	7	7	25	23	7	15	2	74	78	8	6	45	68	-65	9	9	26	287	286
7	7	7	12	-16	7	15	3	15	-1	8	6	46	75	-73	9	9	27	267	286
7	7	7	185	-173	8	15	0	61	64	8	6	47	102	-119	9	9	28	285	-284
7	7	7	38	-25	8	15	1	36	38	8	6	48	52	-56	9	9	29	27	27
7	7	7	165	-156	8	15	2	136	156	8	6	49	61	-61	9	9	30	152	-158
7	7	7	24	-10	8	15	3	57	51	8	6	50	163	-176	9	9	31	203	-205
7	7	7	84	86	8	15	4	29	29	8	6	51	223	-233	9	9	32	170	120
7	7	7	112	118	8	15	5	40	57	8	6	52	131	-131	9	9	33	186	175
7	7	7	100	94	8	15	6	95	102	8	6	53	67	-66	9	9	34	123	-108
7	7	7	190	-183	8	15	7	28	29	8	6	54	25	-21	9	9	35	127	-123
7	7	7	33	-21	8	15	8	29	33	8	6	55	87	-86	9	9	36	109	105
7	7	7	157	148	8	15	9	22	22	8	6	56	110	-109	9	9	37	15	18
7	7	7	101	-97	8	15	10	33	33	8	6	57	27	-27	9	9	38	99	-100
7	7	7	125	125	8	15	11	33	33	8	6	58	109	-109	9	9	39	141	-137
7	7	7	10	-	8	15	12	30	33	8	6	59	24	-24	9	9	40	259	-257
7	7	7	11	-	8	15	13	109	109	8	6	60	157	-142	9	9	41	98	-106
7	7	7	12	-	8	15	14	61	67	8	6	61	23	-23	9	9	42	16	16
7	7	7	5	-	8	15	15	38	43	8	6	62	81	-81	9	9	43	57	-59
7	7	7	8	-	8	15	16	109	109	8	6	63	187	-179	9	9	44	36	36

OBSERVED AND CALCULATED STRUCTURE FACTORS FOR (PT3S2(P(CH3)2(C6H5))6) (R(C2H5)4)2

PAGE 14

H	K	L	FO	FC	H	K	L	FO	FC	H	K	L	FO	FC	H	K	L	FO	FC	H	K	L	FO	FC
9	5	7	179	182	9	11	7	65	58	10	4	12	89	93	11	1	1	168	-178	11	7	5	53	48
9	5	8	126	126	9	11	8	259	226	10	4	13	17	-14	11	1	2	226	-246	11	7	6	37	30
9	5	9	143	142	9	11	9	110	94	10	4	14	27	22	11	1	3	57	59	11	7	7	73	-69
9	5	10	147	148	9	11	10	204	-177	10	4	15	68	60	11	1	4	136	143	11	7	8	56	-65
9	5	11	77	79	9	11	11	181	172	10	6	0	251	251	11	1	5	75	73	11	7	9	74	72
9	5	12	46	40	9	11	13	112	98	10	6	1	158	169	11	1	6	53	-56	11	7	10	34	43
9	5	13	30	33	9	11	13	163	-160	10	6	2	172	-174	11	1	7	102	-110	11	7	11	60	-49
9	5	14	27	23	9	11	13	77	-65	10	6	3	106	-106	11	1	8	22	-3	11	9	0	19	8
9	5	15	15	14	9	11	13	105	111	10	6	4	60	61	11	1	9	103	110	11	9	1	56	-70
9	5	16	11	11	9	11	13	16	5	10	6	5	5	9	11	1	10	21	13	11	9	2	50	-53
9	5	17	15	14	9	11	13	543	580	10	6	6	69	64	11	1	11	57	-60	11	9	3	1	5
9	5	18	9	9	9	11	13	366	386	10	6	7	69	66	11	1	12	55	-63	11	9	4	70	63
9	5	19	2	2	9	11	13	83	96	10	6	8	59	52	11	1	13	45	-40	11	9	5	108	-101
9	5	20	18	19	9	11	13	1	14	10	6	9	96	92	11	1	14	122	-118	11	9	6	163	-164
9	5	21	10	10	9	11	13	29	22	10	6	10	44	47	11	1	15	98	-103	11	9	7	169	-148
9	5	22	10	10	9	11	13	17	17	10	6	11	54	51	11	1	16	83	-92	11	9	8	176	-155
9	5	23	11	11	9	11	13	74	73	10	6	12	25	21	11	1	17	24	27	11	9	9	28	-13
9	5	24	6	6	9	11	13	188	-190	10	6	13	68	57	11	1	18	32	33	11	11	0	109	-105
9	5	25	4	4	9	11	13	235	229	10	6	14	100	92	11	1	19	103	108	11	11	1	8	-12
9	5	26	14	14	9	11	13	228	233	10	6	15	133	138	11	1	20	14	12	11	11	2	61	-58
9	5	27	8	8	9	11	13	93	-100	10	6	16	106	-109	11	1	21	178	-186	11	11	3	266	-284
9	5	28	2	2	9	11	13	174	107	10	6	17	142	-141	11	1	22	36	-35	11	11	4	207	-218
9	5	29	6	6	9	11	13	174	192	10	6	18	20	15	11	1	23	216	234	11	11	5	90	99
9	5	30	4	4	9	11	13	60	63	10	6	19	131	131	11	1	24	26	26	11	11	6	8	28
9	5	31	14	13	9	11	13	164	-188	10	6	20	98	95	11	1	25	212	-223	11	11	7	106	-117
9	5	32	5	5	9	11	13	173	-184	10	6	21	173	-161	11	1	26	13	-14	11	11	8	56	50
9	5	33	1	1	9	11	13	142	158	10	6	22	34	37	11	1	27	100	96	11	11	9	57	63
9	5	34	8	7	9	11	13	152	-158	10	6	23	208	193	11	1	28	23	-28	11	11	10	52	-64
9	5	35	6	6	9	11	13	115	-163	10	6	24	24	-16	11	1	29	55	10	11	11	11	157	-163
9	5	36	10	10	9	11	13	62	60	10	6	25	133	-121	11	1	30	201	-214	11	11	12	69	-74
9	5	37	14	13	9	11	13	103	-108	10	6	26	69	-67	11	1	31	59	54	11	11	13	84	91
9	5	38	3	3	9	11	13	22	-26	10	6	27	32	-32	11	1	32	91	-92	11	11	14	25	-14
9	5	39	2	2	9	11	13	114	-121	10	6	28	29	25	11	1	33	66	69	11	11	15	93	-96
9	5	40	1	1	9	11	13	72	-71	10	6	29	29	-25	11	1	34	70	-68	11	11	16	108	-117
9	5	41	2	2	9	11	13	53	-49	10	6	30	10	-11	11	1	35	111	-109	11	11	17	145	-149
9	5	42	1	1	9	11	13	82	91	10	6	31	113	103	11	1	36	127	127	11	11	18	148	-159
9	5	43	1	1	9	11	13	133	-143	10	6	32	56	53	11	1	37	99	99	11	11	19	110	-113
9	5	44	1	1	9	11	13	60	62	10	6	33	203	-177	11	1	38	149	-158	11	11	20	70	-72
9	5	45	1	1	9	11	13	22	-24	10	6	34	81	75	11	1	39	63	65	11	11	21	58	-62
9	5	46	1	1	9	11	13	64	65	10	6	35	307	255	11	1	40	95	85	11	11	22	58	-71
9	5	47	1	1	9	11	13	62	57	10	6	36	59	42	11	1	41	73	60	11	11	23	58	55
9	5	48	1	1	9	11	13	187	-197	10	6	37	105	96	11	1	42	38	34	11	11	24	58	55
9	5	49	1	1	9	11	13	104	-114	10	6	38	151	136	11	1	43	223	233	11	11	25	29	-39
9	5	50	1	1	9	11	13	109	99	10	6	39	109	99	11	1	44	16	14	11	11	26	92	-105
9	5	51	1	1	9	11	13	86	93	10	6	40	83	83	11	1	45	209	-218	11	11	27	17	-113
9	5	52	1	1	9	11	13	176	-179	10	6	41	95	96	11	1	46	51	53	11	11	28	86	-192
9	5	53	1	1	9	11	13	64	65	10	6	42	273	296	11	1	47	69	66	11	11	29	80	-74

OBSERVED AND CALCULATED STRUCTURE FACTORS FOR (PT3S2(P(CH3)2(C6H5))6) (R(C2H5)4)2

H	K	L	FO	FC	H	K	L	FO	FC	H	K	L	FO	FC	H	K	L	FO	FC	H	K	L	FO	FC
12	4	8	194	199	12	8	0	166	169	13	1	6	1	-11	13	5	0	66	70	14	0	0	136	147
12	4	9	85	-86	12	8	1	78	-72	13	1	7	115	-130	13	5	1	132	129	14	0	2	126	-139
12	4	10	167	-163	12	8	2	115	-113	13	1	8	38	-39	13	5	2	92	-96	14	0	4	61	74
12	4	11	41	42	12	8	3	21	-19	13	1	9	130	134	13	5	3	35	-45	14	2	0	46	47
12	6	0	188	196	12	8	4	46	43	13	3	0	51	-50	13	5	4	112	121	14	2	1	93	-98
12	6	1	145	159	12	8	5	91	83	13	3	1	63	-72	13	5	5	35	-35	14	2	2	30	-23
12	6	2	176	-178	12	8	6	46	-39	13	3	2	23	11	13	5	6	100	-103	14	2	3	54	49
12	6	3	40	39	13	10	0	76	-73	13	3	3	26	-2	13	5	7	98	105	14	2	4	24	23
12	6	4	99	104	13	11	0	142	146	13	3	4	58	58	13	7	0	231	239	14	2	5	51	51
12	6	5	41	31	13	11	1	103	-113	13	3	5	28	37	13	7	1	39	4	14	4	0	24	-26
12	6	6	33	60	13	11	2	107	-108	13	3	6	148	-151	13	7	2	170	-173	14	4	1	66	69
12	6	7	38	49	13	11	3	79	87	13	3	7	49	-47	13	7	3	33	16	14	4	2	26	-19
12	6	8	54	49	13	11	4	57	62	13	3	8	209	207	13	7	4	58	59	14	4	3	64	62

PARTIAL COPYRIGHT LICENCE

I hereby grant the right to lend my thesis or dissertation (the title of which is shown below) to users of the University of Victoria Library, and to make single copies only for such users or in response to a request from the library of any other university, or similar institution, on its behalf or for one of its users. I further agree that permission for extensive copying of this thesis for scholarly purposes may be granted by me or a member of the University designated by me. It is understood that copying or publication of this thesis for financial gain shall not be allowed without my written permission.

Title of Thesis/Dissertation

SOME COMPLEXES OF Pt(II) AND Pd(II) WITH SULFUR LIGANDS

Author



REIKO ONO

February 1983
