

Intercultural Computer-Mediated Communication Exchange and the Development of  
Sociolinguistic Competence

by

Mathy Ritchie

B.A. Université du Québec à Montréal, 1994

M.A. Université du Québec à Montréal, 1997

A Dissertation Submitted in Partial Fulfillment of the  
Requirements for the Degree of

DOCTOR OF PHILOSOPHY

in the Department of Curriculum and Instruction

©Mathy Ritchie, 2009

University of Victoria

All rights reserved. This thesis may not be reproduced in whole or in part, by photocopy or other means, without the permission of the author.

Supervisory Committee

Intercultural Computer-Mediated Communication Exchange and the Development of  
Sociolinguistic Competence

by

Mathy Ritchie

B.A. Université du Québec à Montréal, 1997

M.A. Université du Québec à Montréal, 1994

Supervisory Committee

Dr. Kathy Sanford, Supervisor  
Department of Curriculum & Instruction

Dr. Ted Riecken, Departmental Member  
Department of Curriculum & Instruction

Dr. Catherine Caws, Outside Member  
Department of French

Dr. Ulf Schuetze, Outside Member  
Department of German and Slavic Studies

## Abstract

## Supervisory Committee

Dr. Kathy Sanford, Supervisor  
Department of Curriculum & Instruction

Dr. Ted Riecken, Departmental Member  
Department of Curriculum & Instruction)

Dr. Catherine Caws, Outside Member  
Department of French

Dr. Ulf Schuetze, Outside Member  
Department of German and Slavic Studies

The main goal of this study was to investigate whether computer-mediated communication (CMC) intercultural exchange offers the conditions necessary for the development of the sociolinguistic competence of L2 learners. The secondary goal was to provide a description of the characteristics of the exchange as a language practice regarding language learning and cultural contact. Non-native speakers (NNS) of French in British Columbia interacted through computer-mediated communication with native speakers (NS) of French in Quebec over the course of one school semester. The data for this study included the transcripts of text-based chat discussions and of a group forum, and answers to questionnaires and interviews. Drawing on the sociocultural perspective, this study used a qualitative approach to analyze the collected data. The framework used to guide the sociolinguistic inquiry consisted of *The Common European Framework of Reference for Languages* (Council of Europe, 2001). The findings of this study suggest that intercultural CMC exchange offers positive conditions for the development of this competence. NNS were exposed to sociolinguistic variation and made minor changes in their use of sociolinguistic elements, showing that they developed sensitivity to the vernacular style used by NS. In addition, the exchange fostered the creation of a collective

meaning that allowed L2 learners to participate in meaningful interactions and to increase their level of confidence. Finally, the exchange allowed participants to experience the dimension of “culture as individual” (Levy, 2007), an aspect of culture that encouraged them to share their personal views on culture and to connect on a personal level with their NS partners.

## Table of Contents

Supervisory Committee .....	ii
Abstract .....	iii
Table of Contents .....	v
List of Tables .....	vii
List of Figures .....	viii
Acknowledgments .....	ix
Dedication .....	x
I. Introduction .....	1
A. Rationale .....	1
B. CMC in the Second/Foreign Language Classroom: A Brief Overview .....	5
C. Purpose of the Study and Theoretical Framework .....	7
D. Design of the Study .....	9
E. Outline of this Dissertation .....	11
II. Literature Review .....	13
A. CMC in the Second/Foreign Language Classroom .....	13
B. Intercultural CMC exchange .....	17
C. Limitations in the Research .....	25
D. Sociolinguistic Competence in SLA .....	27
E. Sociolinguistic Competence and Pedagogy .....	31
F. Conclusion .....	34
III. Methodology .....	36
A. Participants .....	40
B. Setting .....	41
C. Structure and Activities .....	42
D. Data Collection .....	44
E. Data Analysis .....	45
1. <i>Analysis of the Sociolinguistic Aspect of the Intercultural CMC Exchange</i> .....	45
2. <i>Analysis of Language Practice</i> .....	49
F. Conclusion .....	52
IV. Results: Sociolinguistic Competence .....	53
A. Sociolinguistic Elements in Online Chat and Forum .....	54
1. <i>Linguistic Markers of Social Relations</i> .....	54
2. <i>Politeness Conventions</i> .....	62
3. <i>Expressions of Folk-Wisdom</i> .....	66
4. <i>Register Differences</i> .....	67
5. <i>About the Forum</i> .....	68
6. <i>Discussion</i> .....	71
B. Differences in the Use of Sociolinguistic Elements .....	74
C. Looking for Sociolinguistic Competence Development .....	80
1. <i>Greetings</i> .....	80
2. <i>Expletives</i> .....	85
3. <i>Hedges</i> .....	87
4. <i>Register</i> .....	88

D. Discussion on Sociolinguistic Competence .....	89
V. Results: Characteristics of Language Practice .....	94
A. Language Learning .....	95
1. <i>Language Aspect in Post-Study Questionnaires and Interviews</i> .....	95
2. <i>Looking for More Clues: A Search for Negotiation of Meaning</i> .....	101
B. Cultural Contact .....	108
1. <i>Cultural Contact in Post-Study Questionnaires and Interviews</i> .....	108
2. <i>Culture as Individual</i> .....	110
C. CMC Aspect .....	115
1. <i>CMC Aspect in Interviews</i> .....	115
2. <i>Negative Aspects of Tool in Post-Study Questionnaires</i> .....	117
D. Discussion .....	118
E. Discussion on Participation .....	121
VI. Conclusion .....	125
A. Summary of Findings .....	125
1. <i>Sociolinguistic Competence</i> .....	125
2. <i>Characteristics of Language Practice</i> .....	126
B. Pedagogical Implications .....	129
1. <i>Before the Exchange</i> .....	133
2. <i>During the Exchange</i> .....	135
3. <i>After the Exchange</i> .....	136
C. Directions for Further Research .....	136
D. Final Conclusions .....	137
References .....	140
Appendixes .....	154
Appendix A. Topics and Questions Guiding the Online Discussions .....	154
Appendix B. Form for Participants .....	156
Appendix C. Pre-Questionnaire on Language Use .....	157
Appendix D. Post-Study Questionnaire and Interview .....	158
Appendix E. Post-Study Questionnaire (Native Speakers) .....	159
Appendix F. Consent Form .....	160

## List of Tables

Table 1 <i>Overview of Aspects Investigated in Intercultural CMC Exchange</i> .....	18
Table 2 <i>Steps for Analysis of Language Practice</i> .....	50
Table 3 <i>Examples of Negotiation of Meaning Moves</i> .....	51
Table 4 <i>Choice of Expletives</i> .....	76
Table 5 <i>Answers Related to Language Learning in Post-Study Questionnaires</i> .....	95
Table 6 <i>Answers Related to the Learning of New Vocabulary and Expressions in Post-Study Interviews</i> .....	97
Table 7 <i>Answers Related to Confidence in Interviews</i> .....	99
Table 8 <i>Description of Online Chat and Forum in the Interviews</i> .....	100
Table 9 <i>Answers Related to Cultural Contact in Post-Study Questionnaires and Interviews</i> ....	109
Table 10 <i>Comparing Online Chat to Face-to-Face Interaction</i> .....	115
Table 11 <i>Learning Objectives for the Development of Sociolinguistic Competence with Intercultural CMC Exchange</i> .....	132
Table 12 <i>Planning of Intercultural CMC exchange with Focus on Sociolinguistic Competence</i> .....	133

## List of Figures

Figure 1 <i>The Learner's Competences (Council of Europe, 2001)</i> .....	47
Figure 2 <i>Sociolinguistic Competence (Council of Europe, 2001)</i> .....	48
Figure 3 <i>Review of Analysis</i> .....	52
Figure 4 <i>Linguistic Markers of Social Relations (Council of Europe, 2001)</i> .....	54
Figure 5 <i>Politeness Conventions (Council of Europe, 2001)</i> .....	62
Figure 6 <i>Display of Sociolinguistic Elements with CMC Tools</i> .....	72
Figure 7 <i>Use of Sociolinguistic Elements by NNS and NS</i> .....	79
Figure 8 <i>Overview of Factors Supporting the Development of Sociolinguistic Competence</i> .....	129
Figure 9 <i>Sociolinguistic Elements to Expect in Chat Exchanges of Functional Groups</i> .....	130

## Acknowledgments

First, I would like to thank my supervisor Kathy Sanford, for her inspiring and encouraging way of guiding me to a deeper understanding of my work and for her invaluable comments during the completion of this dissertation.

I am very grateful to the other members of my committee, Catherine Caws, Ulf Schuetze, and Ted Riecken for their precious comments and constant feedback. I also wish to express my thankfulness to all the subjects in my study. They have all dedicated some of their valuable time for my curiosity.

Lastly, I would like to thank Craig, my mother Lynda, and my brother Pat for supporting me with their love and understanding.

## Dedication

Valmont Ritchie (1947-1992)

## I. Introduction

### A. *Rationale*

Learning to speak a second language involves much more than learning a linguistic code. As language skills develop, learners become aware of all the complexity and richness of the second/foreign language as it is inscribed in cultural and discourse practices of a community. Language educators recognize that the social and cultural dimensions of language use are essential for successful communication; they are continuously looking at ways of integrating objectives and strategies in the language curriculum to support L2 learners in the development of these aspects. Educators know that these aspects are hard to teach in a classroom and that the most efficient way is to provide learners with authentic contact with the speakers and the culture of the language to be learned. Having this connection can be difficult for language learners who do not have easy access to native speakers in their immediate surroundings.

In Canada, official status has been given to English and French in Parliament and the federal courts as early as 1867 with the *British North America Act*. Today, with a population close to 30 million inhabitants, Anglophones count for 59% of the population, Francophones for 23% of the population, and Canadians whose mother tongue is neither English nor French make up 18% of the population (Office of Commissioner of Official Languages, 2008). Quebec is the only province where the majority of its population speaks French as a first language. However, there are almost one million French-speaking people living elsewhere in Canada. Almost a quarter of these Francophones live in New Brunswick (32.3% of Francophones). In the other provinces and territories, the percentage of the population who declared French as a first language varies from 1.3 % to 4%.

Like other industrialized nations, Canada recognizes second language learning as an essential part of a basic education. For Anglophones students wanting to learn French, different programs are offered: core French, intensive French and immersion programs. The Core French education program is designed to enable students to understand and communicate in French, as well as to experience francophone culture (B.C. Education, 2001). Usually, core French education begins in grade four, continues until grade 8 and then becomes optional. A report published by the Canadian Parents for French (2004) showed that one Canadian student in ten decides to complete grade 12 French. The report also states that almost half of the students say that they are unable to understand the spoken language at graduation. The intensive French is an enrichment of the actual core French program. In this program, students receive a period of intensive exposure which corresponds to three to four times the number of hours of instruction normally devoted to French with the Core French program. A bulletin published by the Canadian Parents for French (2007) shows that in British Columbia and in the rest of Canada, Core French is still the most popular program to learn French. Indeed, this report showed that in Canada, 1,600,000 students were enrolled in core French, 300 000 students were enrolled in French immersion, and 10 000 students were enrolled in Intensive French.

The immersion model introduced in the 1970's is very different from the two others. In the French immersion (FI) program, students acquire their L2 through the study of academic disciplines such as mathematics, science and history. In brief, it means that students receive most of their instruction in their L2. Positive findings provided by research have contributed to the growth and development of FI programs for over three decades. Research studies have shown that students enrolled in the FI program are more likely to develop "native-like" skills in reading

and oral comprehension and to develop a greater competence in French upon graduation than the students graduating from the core French program (Swain, 2000).

In the province of British Columbia, in the 2006 census, 7.2% of the population declare that they knew both English and French (Statistics Canada, 2006). Students learning French in this province either in core French, intensive French or in the immersion programs find themselves in a similar situation to learners of a foreign language. Indeed, the language to be learned is barely spoken in the surrounding community so exposure to French is largely limited to the classroom. The lack of contact with the target language community has remained a problematic issue for these learners. Indeed, research done in the FI context have shown that compared to Canadian Francophones of the same age, students in immersion lack sociolinguistic competence in that they rarely or never use informal variants and that they overuse language forms that are formal (Nadasdi, Mougeon & Rehner, 2005). In other words, students in FI learn to use the variety of French useful for academic purposes, an “academic language style” but do not acquire the variety necessary for informal contact with each others, a “vernacular style” (Tarone & Swain, 1995). Researchers have recognized that contact with the speakers of the other language and its culture “is essential if the goals of such learning are sociocultural as well as linguistic” (MacFarlane & Wesche, 1995, p.255).

Even more recently, contact with the target culture has been recognized as important in second language acquisition (SLA) with the shift in foreign language education from a focus on communicative competence to a shift on intercultural competence (Thorne, 2005). For example, according to the Standards for Foreign Language Education in the 21<sup>st</sup> Century (American Council on the Teaching of Foreign Languages, 1999), “it is critical to provide opportunities for many different kinds of interactions with members of other cultures, so that students draw

informed conclusions and develop sensitivity to the perspectives, practices, and products of others” (p.49). Foreign language specialists have come to agree that to be able to interact appropriately with members of the target culture, learners have to also learn the rules of language use and the cultural context within which the language is spoken (Ballou, 2002).

With the start of the 21<sup>st</sup> century and with the development of global communication networks and their integration in the language classroom, opportunities for contact with other cultures have become easier.

The use of Internet technologies to encourage dialogue between distributed individuals and partner classes proposes a compelling shift in L2 and foreign language education, one that ideally moves learners from simulated classroom-based contexts toward actual interaction with expert speakers of the language they are studying (Thorne, 2005, p. 3). Online exchanges, often termed “telecollaboration”, generally include linguistic, pragmatic as well as cultural goals for the participants involved. Thorne adds (2005):

[...] the recent surge in pedagogical and research efforts in this area suggest that ICFLE [intercultural-mediated intercultural foreign language education] is beginning to exert a significant and broad-based influence on the character, processes, and perhaps even goals of mainstream foreign language education (p. 3).

Today, language educators all around the world are organizing online exchanges because they recognize their potential in bringing the target language and culture together to L2 learners. As a consequence, computer-mediated communication (CMC), which refers to communication that takes place between human beings via the use of online tools such as e-mail, discussion forums, electronic bulletin boards or text and oral chat, has also received significant attention for its potential in facilitating language skills development. Through CMC, language learners have

the opportunity to communicate in meaningful ways and to be exposed to contextualized authentic language, two factors described as essential for the development of the communicative competence of learners (Luke, 2006). In brief, CMC does not only offer the possibility for L2 learners to connect with other language learners or native speakers, it also offers conditions recognized as facilitating language skills development. Because of the many opportunities CMC offers to language learners, the many factors in a CMC exchange, and its changing nature, many aspects of CMC still remain to be researched.

This dissertation presents an investigation of a CMC exchange between native speakers (NS) and non-native speakers (NNS) of French as a possible way to improve L2 learners' sociolinguistic competence. The acronyms NS and NNS are common in academic writing and used to distinguish between a person who learned the target language (French in this study) after gaining a native command of their native tongue (NNS), and a person who was raised speaking the target language (NS). Like many language learners in British Columbia, the NNS involved in this study have not had many opportunities for interactions with native speakers and their culture outside the classroom. The idea was to find out whether contact with NS through CMC would be beneficial for L2 learners' development of sociolinguistic competence.

### *B. CMC in the Second/Foreign Language Classroom: A Brief Overview*

Many second and foreign language educators have embraced the use of CMC in the classroom for the simple reason that it allows language learners to connect with other language learners or with NS of the language studied, the "target language". An online exchange is a very exciting activity for language educators who are constantly looking for ways of engaging students in meaningful interactions. Besides this principal characteristic, CMC also offers conditions recognized as promoting language skills development. Indeed, CMC has been

described as an environment that offers a natural language setting where communication takes precedence over form, which promotes communication amongst participants, and which allows for expansive feedback from one learner to another (Kelm, 1996).

The use of asynchronous CMC such as e-mail has been described as an effective pedagogical tool in the foreign language classroom for many reasons. Firstly, as mentioned above, it gives learners the opportunity for authentic language use and meaningful communication setting. Secondly, compared to face-to-face discussion and to synchronous tools such as chat, this environment affords learners with time to reflect on what they want to say or write, therefore promoting more sustained interactions and greater syntactic complexity (Sotillo, 2000). In addition, this environment seems to promote personal connections between intercultural partners (Lomicka, 2006).

Synchronous CMC (communication in real-time such as text-chat) has also generated a lot of support because it mimics oral conversation without involving the potential pressure of a face-to-face discussion. Thus, chat has been described as a conversation in slow-motion (Beauvois, 1992; Payne & Whitney, 2002). Furthermore, it allows learners to use a discourse that is similar to an oral conversation while also providing them with more time to concentrate and to reflect on the form and content of their intervention (Abrams, 2003; Warschauer, 1996). In these interactions, learners do not have to worry about pronunciation and judgment from classmates. Studies have shown that students participate more frequently and more equally in online discussions when compared to regular face-to-face in class discussion (Beauvois, 1997; Kelm, 1996; Kern, 1996; Warschauer, 1996). Moreover, online discussions allow for a more learner-centered environment where students are willing to take more risks and use less of their first language to communicate than in face-to-face interactions (Abrams, 2006).

Not only can CMC promote language skills development, it can also promote the development of the cultural knowledge of L2 learners. Indeed, many classroom projects have involved the connection of L2 learners with expert speakers of the language they are studying with a cultural goal in mind. Through CMC, participants may develop meaningful relationships in which they may learn about each other's culture. This potential of CMC is quite significant because the teaching of culture in the L2 classroom has been a concern for language teachers for a long time (Savignon & Sysoyev, 2002).

To summarize, intercultural exchanges by means of CMC have created research and pedagogical interest because they provide opportunities for learners to participate in intercultural dialogue while simultaneously developing the necessary strategies to perform successfully in the activity (Thorne, 2005). Through this process, learners have the opportunity to discover aspects of the other culture and the sociocultural rules that govern the target language. The latter aspect is what is investigated in this paper.

### *C. Purpose of the Study and Theoretical Framework*

The main goal of this study was to investigate whether CMC intercultural exchange offers the necessary conditions for the development of the sociolinguistic competence of L2 learners. The secondary goal was to provide a description of the characteristics of the exchange regarding language learning and cultural contact.

One of the core beliefs in my research is that social interaction plays a fundamental role in the development of cognition and is based on Vygotsky's sociocultural theory (1986). The aspect of sociocultural theory mostly represented in SLA research is that "the human mind is always and everywhere mediated primarily by linguistically based communication" (Lantolf, 2002, p. 104). As a mediated process, SLA is seen as developing when learners engage in social

interactions, often with more capable social members. Within this approach, learners are seen as active agents because they learn by the act of socializing with others. Sociocultural theory recognized that use and learning are inseparable and that consciousness emerges from practice. This social view of language acquisition considers the complexity and richness of SLA and includes other realms of inquiry and practice such as culture and discourse.

My theoretical framework begins with looking at CMC use in the second language classroom and at the characteristics of this practice identified as facilitating language learning. I bring out the relevance of applying the constructs and methods from SLA theory to research on CALL.

I then present research studies on intercultural CMC exchanges which have drawn on sociocultural theory and revealed information on the process and strategies in which learners engaged in this environment. Threaded into this discussion are ideas about second language learning, considering both what we know from SLA theory and on topics researched so far in intercultural CMC exchange.

Further along, a discussion on the problematic of the teaching of sociolinguistic competence in the language classroom is presented. Lyster (1994) defines the concept of sociolinguistic competence as the “capacity to recognize and produce socially appropriate speech in context” (p. 263). *The Common European Framework of Reference for Languages* (Council of Europe, 2001), which provides support and guidance to second/foreign language instructors is presented as a valuable tool to guide the analysis in this research study. This framework provides descriptions of the competences necessary for communication, including a detailed description of the sociolinguistic competence.

Finally, I suggest an intercultural CMC exchange as a possible means to foster the development of the sociolinguistic competence of L2 learners. Students engage in the prescribed activity and the outcomes, regarding the sociolinguistic elements in play as the result of the social interactions taking place in the activity, are shown at the end of the timeline.

#### *D. Design of the Study*

Participants in this study are one group of intermediate French as L2 learners (NNS) in a Canadian university in British Columbia and one group of French NS in a Canadian college in Quebec. The data used in this study comes from twenty-four NNS and twenty-nine NS. The data collection was spread over a period of nine weeks, from January 2007 to March 2007.

The course offered by the university in British Columbia focused on the development of oral and written skills and on the development of knowledge of French culture, whereas the course offered by the college in Quebec focused on French literature and culture. These two groups of students were selected because the objectives of both courses had a cultural aspect, therefore matching the objectives of the online exchange. Instructors were contacted and agreed to integrate the project as part of their course. The learning objectives were chosen by both instructors, and the students were informed of these objectives in writing (participant consent form) and verbally by their respective instructor. The learning objectives for both groups of students participating in this study were as follows: to create bonds between both communities; to discover both their own and the other's culture; to discuss culture in general and expand their horizons; to improve their written and cultural competence; and to familiarize themselves with the different tools for online discussions.

Participants were regrouped randomly in groups of four (2 NS-2 NNS) ideally but there was also groups of three and five students. They were expected to meet weekly for a minimum

period of thirty minutes to discuss in their respective chat-rooms a topic that was introduced to them in class. After discussing the topic over a period of two weeks, they were expected to write a personal piece in a group forum on the same topic. These two activities met the objectives of the respective language course: the chat allowing students to discuss cultural topics with their partners and the forum being a place to expose a personal piece of writing on the cultural topics.

Students interacted on a course management system called Moodle. The design of this web platform is based on socio-constructivist pedagogy that allows for collaborative interactions among students (Brandl, 2005). On this platform, students were able to send e-mails, enter their assigned chat-room and participate in a discussion forum that included all the participants. This system kept track of all the interactions of the participants and thus allowed for the analysis presented in this dissertation. In addition, the NNS filled out pre and post-study questionnaires as well as participated in a post-study interview. The NS filled out a post-study questionnaire in which they gave details on their profile as native speakers.

This study proposes that an online exchange with NS can be utilized to support the development of the sociolinguistic competence by exposing NNS to various registers and by providing them with access to authentic, contextualized language use. This dissertation is primarily concerned with this specific aspect of language development but it is also concerned with the learning environment provided by the intercultural CMC exchange in regards to language and culture contact. Therefore, the research questions have been divided into two main sections.

The first section investigates the development of the sociolinguistic competence using the sociocultural perspective, which posits that language learning occurs when learners are engaged in meaningful social interactions. The transcripts of the students' interactions were analyzed

using a qualitative approach based on the pedagogical framework proposed by the Council of Europe (2001) in order to answer the following main research question:

- 1) Did the intercultural CMC exchange provide the conditions necessary for the development of the sociolinguistic competence of non-native speakers?

Along with this main research question, two sub-questions were also investigated:

- a. What were the differences and similarities in the use of sociolinguistic elements for native speakers and non-native speaker involved in the intercultural CMC exchange?
- b. Was there evidence of sociolinguistic competence development for the non-native speakers involved in the intercultural CMC exchange?

The second section investigates the intercultural CMC exchange and its benefits on language and culture using a qualitative analysis of the answers on the questionnaire and the interviews. This served to address the following question:

- 2) What characteristics of the intercultural CMC exchange as a language practice may support the development of the sociolinguistic competence?

Finally, more broadly, I hoped to make conclusions as to whether the pedagogical approach used in the exchange was appropriate for the teaching of the sociolinguistic competence.

### *E. Outline of this Dissertation*

This chapter has been organized to provide the reader with the rationale, the theoretical framework which guided the research, the factors to analyze, the methods, and scope of the investigation undertaken. As it was previously mentioned, foreign language educators have recognized for a long time that contact with the target culture and language is essential for L2 learners' development of the communicative competence. This study investigates the use of

CMC in providing this essential contact with NS and their culture and in promoting the development of the sociolinguistic-specific aspect of communicative competence.

Chapter 2 provides an overview of research on CMC in the foreign language classroom and more specifically on exchanges which have involved NS and NNS. In addition, this chapter brings to light areas which need further investigation in the field, and argues that the topic under investigation in the present study will contribute to the body of literature.

Chapter 3 presents a review of the research questions, a detailed description of the project, along with the research methods and analyses that were used to answer the research questions.

Chapter 4 provides the results obtained by the investigation relevant to the first research question. This first section is followed by a discussion in order to answer the research question posed.

Chapter 5 provides the results obtained by the investigation relevant to the second research question. This first section is followed by a discussion in order to answer the research question posed.

Finally, chapter 6 concludes this dissertation with a summary of the relevant findings obtained and is followed by a discussion of the implications of the results both for pedagogy and for future research.

## II. Literature Review

In this chapter, I first provide an overview of the scholarly publications in the field of computer-assisted language learning (CALL) and more specifically, I focus on research which has investigated projects connecting NNS and NS of a target language together with the Internet. I also describe studies that have drawn, to various degrees, on sociocultural theory and which have revealed information on the developmental processes afforded to learners in CMC online exchanges. I illustrate that the development of sociolinguistic competence has only been given marginal attention in this field. In addition, I explain the sociolinguistic competence as defined in the field of second language acquisition (SLA).

### *A. CMC in the Second/Foreign Language Classroom*

According to Kern, Ware and Warschauer (2004), research on CALL has started to take a different direction since the beginning of the 21<sup>st</sup> century. The first decade of research on CALL focused on quantifiable and easily measurable aspects of online communication such as the type and amount of text produced by participants. The second decade of online research has pushed for qualitative research that focused on topics such as particular practices of use, on the specific social contexts in which these interactions evolved, and on the type of interaction they foster. “This required a shift from primarily quantitative research methods to principally qualitative methods that attempted to account for classroom cultures as well as language use” (p. 244). Accordingly, research projects have evolved from analyzing the use in a single classroom to long-distance collaboration projects focusing on the possibilities for linguistic and cultural learning. There is now an emphasis on using computers to create authentic discourse communities with meaningful interactions (Kern & Warschauer, 2000).

This change can be attributed to the sociocultural perspective on language development that has influenced the dynamic of CALL. Indeed, many researchers conceptualize CALL as a field within applied linguistics (Arnold & Ducate, 2006) and have argued for the applications of the theories of this field to CALL. In 1997, Chapelle suggested that CALL researchers use SLA theory as a basis for guidance in framing CALL research questions and in discovering relevant research methods. Almost ten years later, she added: “recent studies demonstrate the relevance of the constructs and methods from SLA research for the study of CALL” (Chapelle, 2006, p. 60).

Vygotsky’s sociocultural theory and language socialization are often positioned as the primary theoretical framework in much of the current research in SLA (Zuengler and Miller, 2006). Within the sociocultural theory, language is viewed as developing through interaction with others, and then through integration into the individual’s mental structure. According to Ellis (1999), this social view of language acquisition:

[..] calls for research that adopts a more holistic approach to discourse involving learners and their settings, and which, therefore, employs qualitative methods that are more sensitive to the ways in which interactions are constructed by participants as they dynamically negotiate not just meaning but also their role relationships and their cultural and social identities (p. 17)

The sociocultural approach to language development has paved the way to many research studies and has influenced classroom practices. Examples of recommendations for classroom practices drawn from these studies include ways to facilitate student participation and ways to use dialogue between peers to mediate learning (Zuengler and Miller, 2006). According to Warschauer (2006), the concept of social learning helps researchers understand how learners incorporate others’ linguistic chunks in their own speech and how they refine their writing for,

and with input from, an authentic audience. O'Rourke (2005) adds that the "sociocultural perspective is motivated by the conviction that interaction in CMC should be seen above all as a socially and culturally situated activity engaged in by learners as agents who co-construct not only shared meanings, but also their own roles" (p.434). So, as much of the research in SLA theory has been framed within the sociocultural perspective, so are many research studies in CALL today.

One area that has received much attention in the second and foreign language classroom is CMC for its ability to expose learners to authentic language use. CMC refers to activities such as e-mail, bulletin boards, and blogs, which are described as asynchronous CMC. Amongst the various asynchronous tools available, e-mail projects have been probably the most common activity used in second and foreign language classrooms (Lomicka, 2006). This asynchronous CMC tool has been identified as promoting more sustained interactions and greater syntactic complexity than discourse found in synchronous CMC (Sotillo, 2000). Indeed, in a non-synchronous environment, there is more time to write complete sentences and to focus on the form of the message. Because it is a one-on-one type communication, it fosters personal connections between intercultural partners in which the culture of the other becomes more alive (Lomicka, 2001). Discussion boards which can include a large group of students have also been included in many research projects as they offer a place for students to exchange views and opinions (Furstensberg et al., 2001). This type of tool is recognized as promoting opportunities for "reflective conversation" (Lamy & Goodfellow, 1999) and collaborative discourse. On the other hand, synchronous CMC tools such as text and voice chat, videoconferencing, and instant text messaging, are described as reflecting the spontaneity of a conversation along with instances of negotiation, register, discourse patterns and functions (Abrams, 2003). One of the obvious

advantages of synchronous CMC is the communication in real-time that bring closer the participants and retains the immediacy of the topic. In brief, asynchronous CMC tools are used for a more formal type of writing and synchronous CMC for open-ended discussions and conversation type of activity (Abrams, 2006).

Research has shown that CMC interactions offer many of the conditions identified as facilitating language learning in SLA theory. Indeed, it offers a natural language setting where the focus is on content, and where the development of the topic is controlled by participants. It also encourages participation and collaboration between students and allows for socialization and communication to take precedence over form (Kelm, 1996). Moreover, the nature of written CMC is quite unique as it is a written medium that shares characteristics of the oral form. For example, in the case of text-chat, there is interaction like in an oral conversation but the message expressed by the interlocutor can be seen on the screen so learners have more processing time to understand and to reflect on the form and content of their intervention than in a face-to-face interaction (Payne & Whitney, 2002; Kern, Ware & Warschauer, 2004).

Because of its interactive nature, CMC may also push learners to notice gaps in their linguistic knowledge; they may realize that they do not have the knowledge required to perform in a given communicative situation (Kötter, Shield & Stevens, 1999). This interactive nature also provides a great environment for negotiation of meaning (Blake, 2000; Pellettieri, 2000; Tudini, 2003). Indeed, to participate in these interactions, participants may use strategies such as repetitions, comprehension checks, confirmation checks, and clarification requests to overcome communication breakdowns and establish mutual understanding.

In addition, electronic discussions have been described as leading to more language production and to output that is syntactically more complex with a greater variety of functions

than in face-to-face interactions (Kern, 1995; Payne & Whitney, 2002; Waschauer, 1996). This environment seems to lower learners' inhibitions allowing them to "share the floor" more equally. As a consequence, students have shown an increase of motivation towards learning the target language (Beauvois, 1992; Sullivan & Pratt, 1996; Meunier, 1998).

This overview of general findings in CALL shows that CMC offers an environment in which the conditions for L2 acquisition are maximized. Moreover, it "suggests that the text-based CMC medium can amplify students' attention to linguistic form, offering learners sufficient opportunity to notice the input's lexical and grammatical features" (Smith, 2005, p. 35) and is therefore a possible "cognitive amplifier" (Warschauer, 1997). In the next section, I focus on CMC research projects that have investigated interactions between NS and NNS.

### *B. Intercultural CMC exchange*

Projects connecting NNS and NS into collaborative tasks through CMC, often referred to as "telecollaboration", have been used in the second/foreign language classroom for the evident reason that they allow language learners access to NS and their culture. The term telecollaboration does not automatically imply an exchange between NS and NNS which is why, in this study, I use the form of intercultural CMC exchange because it brings together the nature of the communication and the tool used to communicate. Research has addressed many angles of language learning in these types of projects. Table 1 shows an overview of the many angles researched which focused on three key themes also previously identified by Kern, Ware and Warschauer (2004): linguistic interaction and development, intercultural awareness and learning, and development of new multiliteracies and their relations to identity.

Table 1 *Overview of Aspects Investigated in Intercultural CMC Exchange*

Aspects	Research studies
Enhancement of cross-cultural awareness and cultural learning	Belz, 2002, 2003; Belz & Müller-Hartman, 2003; Connelos & Olivia, 1993; Gray & Stockwell, 1998; Lee, 1997; O'Dowd, 2003
Opportunities for negotiation of meaning	Kitade, 2000; Kötter, 2003; Toyoda & Harrisson, 2002; Tudini, 2003
Effects of online interaction on writing skills	Davis & Thiede, 2000; Savignon and Roithmeier, 2004
Student attitudes and perceptions	Hertel, 2003; Lee, 2004
Cultural contact afforded by CMC	Hanna & de Nooy, 2003; Kramsh & Thorne, 2002; Thorne, 2003; Ware, 2005
Literacy and identity	Lam, 2003
Pedagogical design of intercultural projects	Müller-Hartman, 2000; Furstenberg, Levet, English & Maillet, 2001; von der Emde, Schneider & Kötter, 2001
Acquisition of pronouns of address	Belz & Kinginger, 2002
Acquisition of modal particles	Belz & Vyatkina, 2005

The different angles presented in Table 1 show that researchers have recognized CMC as an authentic communication medium with its own patterns of interaction, and have recognized the need to understand how culture, identity, and literacy are transmitted in this environment

(Kern, Ware & Waschauer, 2004). The goals of these research projects are diverse but according to Thorne (2005), at the base of “Internet-mediated intercultural foreign language education pedagogy is the desire to cultivate conditions for the development of intercultural competence” (p. 5). Although this type of exchange includes interaction between two cultures, research has shown that the contact provided by the CMC environment involves multiple dimensions and that intercultural understanding does not automatically emerge (Belz, 2002; Kern, 2000; O’Dowd, 2003). Therefore, a number of research studies have focused on the pedagogical design of intercultural projects and on the factors that may have an influence on how cultural understanding is negotiated. These research studies have been informed by recent approaches, strategies and techniques advocated for language and culture teaching such as the work of Byram (1997) and Kramsch (1998), amongst others. According to Kramsch, culture “can be defined as membership in a discourse community that shares a common social space and history, and common imaginings” (1998, p. 10). Kramsch also mentions that one of the primary objectives of foreign language learning is to be able to see the world through another’s eye while being conscious of oneself. Results of these investigations have brought up the importance of the design of tasks that should involve collaboration between partners. These tasks should enable learners to become more objective about their own culture, provide insight and perspective, and allow for the exploration of stereotypes, amongst others (Levy, 2007). More recently, researchers have been looking into the kind of cultural contact afforded by CMC (Hanna & de Nooy, 2003; Kramsch & Thorne, 2002; Thorne, 2003). The results of these studies have shown that many factors such as differences in communicative genres, linguistic styles, and academic cultures can all have an impact on how cultural understanding will develop and have “pointed out to the

importance of investigating what successful participation means in different contexts” (Kern, Ware & Waschauer, 2004, p.253).

Recognizing that the concept of culture can be subject to many interpretations, Levy (2007) suggests an approach which starts with what we know about the concept of culture and proposes to examine the concept from five perspectives: culture as elemental; culture as relative; culture as a group membership; culture as contested; and culture as individual. Inspired by the work of Kramsch (1998), Levy underlines the importance of recognizing the perspective of the individual in relation to the group in the development of a pedagogical approach. In his paper, he compared five different CMC projects, and explored which facets of the culture concept is the primary focus in each of them. The results showed that each project responded to many facets of the culture concept, but that some of these aspects were brought forward as a result of the participants, the technologies used, the pedagogical techniques and strategies used (p. 119). Results also show that cultural learning happened when the activities involved interactive exchanges. He argues that more research of this type is required to further the understanding of the kind of cultural contact afforded by the CMC environment. With more descriptions of the many factors in play in specific intercultural CMC exchanges and the dimensions of the cultural concept it displays, “we will be better equipped to develop the pedagogical elements required for the successful practice of culture learning and teaching” (Levy, p. 105).

As it was discussed earlier, researchers have been looking more closely at the learners’ interactions in the CMC environment using discourse analysis techniques to find out which features facilitate L2 acquisition. This type of research has revealed that intercultural CMC involving synchronous CMC such as text and voice chat interaction offer the opportunity to negotiate meaning in authentic language setting (Tudini, 2003; Toyoda & Harrisson, 2002). As a

cognitive process, negotiation of meaning facilitates language acquisition because it increases the speakers' attention to inaccuracy in their speech and may force them to produce modified output, or self-correction (Swain, 1985). Regarding this specific aspect, more research is needed that explores the role of task type in promoting attention to language form along with intercultural learning (Müller-Hartmann, 2000) and that explores the type of negotiation of meaning fostered by different online learning contexts.

More recent work has drawn to various degrees on sociocultural theory and has revealed information on the processes by which NNS and NS collaborate in the construction of knowledge regarding language and culture in telecollaboration. For example, Lee (2004) was interested in finding the conditions that NNS of Spanish found to be necessary to communicate successfully with NS. Both groups of students enrolled in U.S. institutions had to discuss open-ended questions in text-based chat. The researcher analyzed the online discussions, end-of-semester surveys and oral interviews. Results showed that the open-ended online discussions promoted collaborative linguistic scaffolding between the two groups. Indeed, the written interactions showed that the NS assisted the NNS in the composition of their messages in both their content and form. For example, the NS challenged the NNS to produce a more coherent discourse by requesting more information on the topics, by asking for clarification and confirmation checks on the information provided. This researcher suggests that "This collaborative dialogue demonstrates that both the NS and the NNS became involved in a problem-solving activity through social and cognitive engagement" (p.92). In the interviews, the NNS reported that the online exchanges allowed them to observe and imitate the NS' discourse, to incorporate new words and more advanced grammar. The NNS also reported that they noticed

how the NS used vocabulary, grammar and a range of registers that were different from theirs and that they used NS' discourse as a model for their own writing.

Savignon and Roithmeier (2004) looked at evidence of collaborative construction of text and strategies used to sustain collaboration in asynchronous online discussions between English as foreign language students in a German Gymnasium and a class of German as a foreign language students in a U.S. high school. The data consisted of the interactions of the participants on two bulletin boards. Participants had to discuss in English on four different topics with the goal of getting exposure to each other's respective culture and to get exposure to contemporary English for the German students. They found that the discussions showed a strong degree of collaboration. Participants used words and structures from previous postings, they looked up words with the goal of expressing themselves more accurately, and they adopted strategies to keep the conversation going. The researchers also found that students collaborated in the construction of a continuous intercultural text that showed cohesion and coherence. The students participating in this project showed a high level of involvement, developed collaborative strategies and gained insights into each other's culture as well as into varieties of language different from theirs. The researchers concluded that this medium has the potential to engage learners in the interpretation, expression and negotiation of meaning essential for the development of the communicative competence.

Davis and Thiede (2000) questioned the hypothesis that foreign language students interacting with speakers of the target language would become aware of a range of discourse conventions and begin to imitate these conventions. Two students enrolled in an English as foreign language course engaged in an asynchronous conference discussion for a semester with NS of English. Students had to write summaries or critiques of texts and comment on each

other's writing. To test their hypothesis, the researchers analyzed the performances of the foreign language students in terms of syntactic complexity and lexical density. The researchers found that this type of task offered learners "sustained and topically threaded exposure to a variety of discourse models within a sequenced set of writing prompts" (p. 92). They identified emerging patterns and tendencies suggesting that students had adapted their speech and had learned to use a more professional style for the summary and a more intimate style when responding to peers over the semester. At the end of the semester, students were asked to write their reflections on the online interactions. They commented on the changes they were able to bring in their discourse patterns. The researchers concluded that the asynchronous conference discussions not only offer foreign language students exposure to a variety of discourse but also offer possibilities for reflective inquiry on language use.

Hanna and de Nooy (2003) also analyzed the exchanges of learners of French interacting in a French online environment. Two British and two American learners of French interacted on the forum of the French newspaper *Le Monde*. They found that genre of discourse played a crucial role in intercultural communication. Indeed, successful interactions occurred when the NNS adjusted their speech to meet the norms of the specific cultural practice. For example, NNS were successful in their interaction with others when they realized that their ability to contribute to the debate was more critical than politeness and linguistic accuracy. The learners also had to adjust to the tone of the discussion that took the form of a debate. The authors suggested that "genre and culture are being used to explain and justify each other; they are mutually defining, which seems to us an important lesson to be learned" (p.80). They added that learners should get the genre right and the linguistic and cultural opportunities will open. The students in that study

had to perform French through participation in a cultural practice; they practiced “Frenchness” (p.81). In this environment, they were able to witness abstract notions of this specific culture.

By looking at the interactions between NS and NNS with a sociocultural point of view, the studies outlined above have revealed that when engaged in meaningful discussions with NS, learners are pushed to produce coherent discourse that goes beyond linguistic and grammatical accuracy (Lee, 2004). They may recognize different registers, discourse patterns and style and try to imitate these new language forms. Moreover, as Savignon and Roithmeier (2004) have pointed out, in this environment, participants are motivated to participate in the construction of a collaborative discourse, to use strategies to avoid conflict, and are eager to exchange their opinions. In the conclusion of their study, they added “In sum, the high level of participation observed offers compelling evidence of the potential of CMC to engage learners in the interpretation, expression, and negotiation of meaning essential for the development of communicative competence.” Lee (2004) also agreed with that idea when she underlined that through social and cognitive engagement, NS and NNS entered into a collaborative dialogue that led to the acquisition of new lexical and correct grammatical structures.

This type of research is important because it provides detail about the factors that play a role in the development of students’ learning, on the type of learning, and on the learning process fostered by an intercultural CMC exchange. As Chapelle (2008) pointed out, plenty of studies have shown that CMC offers conditions that foster language skills development, but more studies need to provide detailed descriptions of what really goes on between participants. In particular, more studies need to look at how collaborative strategies are developed by participants and at how NS provide support to NNS in the development of linguistic, cognitive, cultural, and other aspects. With a sociocultural approach, we can further our understanding of the alchemy of

language and culture in these environments and at how the norms of discourse and sociocultural aspects are negotiated.

### *C. Limitations in the Research*

According to Abrams (2006) “studies thus far have contributed to our understanding of the way in which CMC can improve L2 language skills; future research must identify which language skills CMC may affect positively and how” (p. 188). Although, the potential of CMC regarding the development of linguistic and cultural knowledge has been shown by the multiple aspects investigated by research so far, there are still many avenues to explore, especially with virtual interactions among NS and NNS groups (Lomicka, 2006).

Many researchers in CALL have investigated the development of skills related to the communicative competence. Indeed, research has shown that the learning environment provided by CMC promoted the development of this competence by providing a meaningful communicative setting that promotes the exchange of ideas over mere form (Kelm, 1996). Moreover, when viewed in the context of sociocultural theory, online discussions offer language learners the possibility to use their language to socialize in meaningful contexts, collaborate, and create cross-cultural communities while at the same time developing their language skills, a setting that has been describe as facilitating the development of the communicative competence.

Despite the fact that there are more research studies in CALL based on SLA theory, very few studies so far have looked at the potential of an intercultural CMC exchange for the development of competences related to the use of language in context such as the sociolinguistic competence. The sociolinguistic competence is concerned with the knowledge and the ability required for language to function in its social dimension (Council of Europe, 2001). One important aspect of this competence is the ability to recognize and use appropriate varieties of

language in a specific communicative setting. CMC seems to have the potential to promote the development of this competence. Indeed, language learners engaging in online conversation with NS have access to authentic language use in real communicative setting. Research studies discussed earlier in this chapter have shown that language learners pay attention to the form of language used by NS such as different registers and are inclined to imitate these language uses. Participants involved in interactive online exchanges not only learn about language use in context but they also learn about each others' culture. In brief, CMC provides interactive access to language and culture in context, something not accessible in the traditional classroom.

However, one research study by Belz and Kinginger (2002) investigated the learning of the acquisition of pronouns of address (specifically, the use of *tu/vous* and *Du/Sein*). The choice of the appropriate pronouns of address can be confusing because it must be made in light of a number of contextual considerations. In this research study, two fourth-semester foreign language students at a U.S. university were involved in a telecollaboration project with a native-speaking peer in France and Germany, respectively. Results showed that by interacting through e-mail in the L2, learners were forced to choose the appropriate pronoun. When a student chose an inappropriate pronoun, the peer interlocutor would focalize overtly on the inappropriateness of this choice. The researchers argue that the telecollaborative learning environment provided L2 learners with a wider range of discourse options than in the traditional classroom and with timely assistance from native-speaking peers. They conclude by saying that telecollaboration may be an appropriate context for L2 linguistic development such as the pronouns of address in French and German.

While Belz and Kinginger (2002) describe the acquisition of the distinction in pronoun of address as part of the L2 pragmatic competence, this research study is the only one to my

knowledge that has investigated such an aspect in a CMC environment. Pragmatic and sociolinguistic competences are not always differentiated in SLA literature but some researchers agree in distinguishing both concepts. For example, Bachman (1990) defines pragmatic competence as the relation between what interlocutors say and what they intended to perform through the utterance. Sociolinguistic competence is related to the appropriateness of the language choice in a given context of a communicative situation. For example, pragmatic competence is related to the act of making a request and sociolinguistic competence to the appropriate choice of register to address the interlocutor when making that request (Council of Europe, 2001).

The investigation undertaken differs from the one by Belz and Kinginger (2002) because it includes the observation of various elements of the sociolinguistic competence in the goal of obtaining a broader picture of the potential of this environment regarding the development of this competence. The next section describes in more detail the sociolinguistic competence and gives an overview of how it has been researched in the field of SLA.

#### *D. Sociolinguistic Competence in SLA*

Sociolinguistic competence refers to the learner's "knowledge of the sociocultural rules of language and discourse" (Brown, 2000, p. 247). In his definition, Brown includes learners' sensitivity to dialect or variety, choice of register, naturalness and knowledge of cultural references and figures of speech. Tarone and Swain (1995) define this competence as the ability of the members of a speech community to adapt their speech to the context in which they find themselves. In a speech community, members learn to use different varieties of their language in different contexts. These researchers explain that a speech community usually has formal language styles and vernacular language styles and that different language functions require

different language forms and structures. For example, a more formal variety will be used in an interview whereas an informal register, sometimes called “vernacular” will be used amongst friends. Lyster (1994) define the concept of sociolinguistic competence as the “capacity to recognize and produce socially appropriate speech in context” (p. 263). Many SLA researchers have been interested in looking at this competence because they have acknowledged L2 learners’ difficulties in acquiring and using the full range of speech styles or to develop “stylistic variation” (Dewaele, 2004).

One way of studying the acquisition of the sociolinguistic competence has been to examine how learners acquire variable forms in their L2, from the more formal ones to the more informal ones. Much of this type of research has been done in the context of French immersion programs in Canada. These research studies have shown trends in the acquisition of sociolinguistic variation. First, the ability for learners to alternate between two sociolinguistic variants is relatively late to emerge in the acquisition of a L2 (Howard, 2006).

Second, L2 learners will generally overuse formal variants and underuse informal variants as shown in a research study by Nadasdi, Mougeon and Rehner (2005). These researchers compared the speech of Canadian francophone students to the one of students from grade 9 and 12 enrolled in French immersion. They compared the use of informal variants such as the deletion of the “ne” particle in negation. Their analysis showed that French immersion students were not able to use other varieties than the formal and hyper-formal forms while Francophones of the same age were using, for a large part, the informal forms. In their discussion, they explain the absence of vernacular variants by the fact that the L2 learners have learned French in the context of the classroom and that they have had limited contact with NS. According to Dewaele (2004), the overuse of formal variants by NNS is one fairly consistent

result of research studies on stylistic variation and it is linked to the difficulty for L2 learners to pick up stylistic variation because of the lack of access to the community of practice of NS.

This phenomenon has also been observed by Tarone and Swain (1995). For these researchers, the fact that immersion students are not able to use an informal variant is linked to the observation that these students “increasingly avoid using their second language in peer-peer interactions as they moved into higher primary grade levels” (p.166). They explained that immersion students generally only know the register used for academic purposes, an “academic style” and do not know the “vernacular style” used for the purposes of playing and arguing among others. The vernacular style is characterized by syntax and vocabulary that “marks the users as members of a close sub-speech community” (p. 168) and as a way for older students to express their identities. Their research is important as it pointed out the need for these students to develop the L2 vernacular language style to be able to communicate with their peers for non-academic purposes. In their conclusion, they present three general positions taken by FI teachers: 1) it is impossible to teach a L2 vernacular style in a FI classroom; 2) it is possible if we involve FI students in activities outside the classroom with NS peers; 3) it is possible if we explicitly teach sociolinguistic variation in immersion classrooms.

A second trend in SLA research on sociolinguistic competence has looked at the conditions required for its development. Results have shown “the important effect of informal contact with the target language, both through native-speaker contact in general and, more particularly, in the target-language community” (Howard, 2006, p. 381). For example, MacFarlane (2001) described the benefits of a brief exchange experience between learners of French as a L2 from Ontario and NS from Quebec, both groups from Grade 6. Results showed that the creation of social relationships facilitated negotiation of meaning and motivated learners

to attempt a more “native-like” performance. Students learned some basic social routines such as how to initiate a conversation, change topics, taking and giving up a turn and also learned idiomatic expressions and colloquial vocabulary. Many research studies have shown that learners who have spent time in the target language community increased their use of informal sociolinguistic markers. Such studies focused on the omission of “ne” (Dewaele & Reagan, 2002; Regan, 1995; Rehner & Mougeon, 1999; Sax, 2003) and the use of the pronoun “on” versus “nous” (Sax, 2003). Both of these elements are normally present in French vernacular style.

In brief, research on sociolinguistic competence in SLA has focused on the differences between native speakers and L2 learners in the use of linguistic variants and on the conditions required for L2 learners to acquire these variants. Many research studies have shown that “authentic interactions with native speakers (NS) allow them to gradually extend their stylistic range in written and oral production and develop a fully-fledged sociolinguistic competence (Dewaele, 2004, p. 302). Dewaele adds that these interactions need to be frequent to have a noticeable effect. In addition, one recurrent finding is the overuse of formal variants by L2 learners which is linked to the limited variation of input they receive in the classroom.

This review of research studies on the acquisition of sociolinguistic competence brought out a few methodological issues related to the measurement of this competence. The measurement of sociolinguistic competence is particular because learners’ success does not equal the use of “standard” forms in the target language. For example, the success of L2 learners can mean that they were able to choose the vernacular style when interacting in an informal communicative situation. Rehner (2002) suggests that variation in advanced learners be measured by comparing how they alternate between forms that are used by NS. One way to do so

is by observing whether they use the expressions used by NS in same communicative situations. Many of the research studies presented above have measured the development of this competence by asking L2 learners to act in role play. Although role-play may reveal some aspects of the learners' competence, it does not seem to provide a fair testing environment for learners. For example, in some of the studies presented above, participants were asked to interact in an "artificial" formal communicative situation and in an informal one. These communicative situations did not offer the richness and the social clues that an authentic conversation can provide. Therefore, observing L2 learners in authentic communicative situation with NS seemed to be an appropriate way to measure the development of the sociolinguistic competence.

This section presented an overview of the many aspects of sociolinguistic competence investigated by SLA researchers. Knowing that it is an essential but rather difficult competence to develop, it is fair to look at tools and strategies used by L2 educators to support learners in their development. This aspect is discussed in the next section.

#### *E. Sociolinguistic Competence and Pedagogy*

The development of the sociolinguistic competence poses no simple problem for language learners and their teachers. Indeed, this competence involves the learning of the sociocultural principles that determine the norms of appropriate behaviour and language use of a specific community, which is difficult to teach in a classroom (Hinkel, 2001). Even if some of the major institutions concerned with foreign and L2 teaching recognized the importance of the sociolinguistic competence, resources which give a good description of the elements involved and which guide the instructors in the teaching and evaluation of this competence are difficult to find. For example, in the description of the objectives of the French immersion program for British Columbia (British Columbia Ministry of Education, 1997) for grade 11-12, it is

mentioned: “develop a sociocultural competence to know how to address his interlocutor and to know how to choose the appropriate register to the communicative situation (translated from French, p. 13). It is suggested that students interact through e-mail with Francophones around the world to experiment with different ways of expression. Besides these general guidelines, there are no descriptions of what is expected from students and no specific objectives to reach. In a similar way, the Core French program for Grade 12 in British Columbia (British Columbia Ministry of Education, 2001), mentions “it is expected that students will adapt language, expressions, and behaviour to suit cultural context” (p. 82). The document does not go further in how to teach or evaluate these skills.

Similar observations can be made in the United States with the document *Standards for Foreign Language Learning in the 21st Century* (American Council on the Teaching of Foreign Languages, 1999). Indeed, the approach that includes “five C’s” of foreign language education (communication, cultures, connections, comparisons, and communities) recognizes that the ultimate goal of today’s foreign language is “the acquisition of the ability to communicate in meaningful and appropriate ways with users of other languages” (p. 3), which includes the linguistic and social knowledge required for effective human-to-human interaction. Besides this reference, no other description of what the “social knowledge” involved is provided.

In contrast, *The Common European Framework of Reference for Languages* (CEFR), which has become a key reference document and a valuable tool for all who are directly involved in language teaching, is one of the only official documents which describe in detail the components of the sociolinguistic competence. This document was designed to provide a common basis for the explicit description of objectives, content and methods in the teaching of modern languages across Europe. The document also defines levels of proficiency to measure

learners' progress at each stage of learning and at the same time, facilitates the mutual recognition of qualifications gained in different learning contexts. The document provides comprehensive details on the competences necessary for communication, recognizing that communicative competence alone is not sufficient for language learners to become efficient communicators. The document includes two major groups of learners' competences: general and communicative. The general competence regroups declarative knowledge, skills and know-how, existential competence, and ability to learn. The communicative competence regroups linguistic, sociolinguistic, and pragmatic competences. The framework provides a good description of elements involved in the sociolinguistic competence: linguistic markers of social relations, politeness conventions, expressions of folk-wisdom, register differences, and dialect and accent. The framework also provides tools to guide instructors in the teaching and the assessment of this competence. For example, there is a grid describing the "sociolinguistic appropriateness" (Council of Europe, 2001, p. 122) to attain at each level of proficiency. Because of its comprehensiveness and because it recognizes language as a sociocultural phenomenon, this document is a good tool for anyone interested in language teaching. More specifically, because of the absence of such a framework in Canada, it is a tool useful for all instructors internationally who are interested in teaching the sociolinguistic competence.

Although sociolinguistic competence is recognized as an important aspect of L2 learners' competency, it remains a concept difficult to grasp, to define and to teach in a classroom. Besides suggesting prolonged and regular contact with NS, suggestions and strategies on how to foster the development of that competence are lacking in language instructors' curriculum. The use of an intercultural CMC exchange may be an alternative solution for addressing the issue of sociolinguistic competence development in the foreign language classroom. In CMC interactions

with NS, L2 learners could learn the social rules that govern the target language. Ideally, this contact would allow L2 learners to discover and integrate different varieties of the target language by engaging in meaningful interactions that foster negotiation of meaning and collaboration.

#### *F. Conclusion*

Intercultural CMC exchanges have been at the center of much of attention because they offer exciting opportunities for the development of intercultural competence as they bring language and culture together to the learners. Kern, Ware and Warschauer (2004) explain that language educators using CMC should engage students in “a new realm of collaborative inquiry and construction of knowledge, viewing their expanding repertoire of identities and communication strategies as resources in process” (p. 254). When viewed in the context of sociocultural theory, online discussions offer language learners the possibility of using their language to socialize, collaborate, and create cross-cultural communities while at the same time developing their language skills. Research indicates that this type of communication enhances language learning and provides a favourable environment for the development of the communicative competence. Belz and Vyatkina (2005) add that in this environment, NNS can witness how NS use language in specific contexts and may broaden “the range of discourse options and subject positions available to classroom learners of language” (p.19). Moreover, the immersion of L2 learners into an L1 online environment seems to be an efficient way for advanced language learners to learn more about language genre and styles.

This chapter also discussed the difficulty encountered in the foreign language classroom regarding the teaching of the sociolinguistic competence. Research on this aspect in the field of SLA has shown that is by having authentic contact with NS that L2 learners develop this

competence. This study suggests that an intercultural CMC exchange may provide a possible solution to this problem, by providing L2 learners with direct contact with NS.

The framework designed by the Council of Europe, the *CEFR* was presented as a useful pedagogical tool for the teaching and assessment of this competence. This framework is discussed further in the next chapter as I present the research methodology of this study.

### III. Methodology

According to Ohta (2000), the sociocultural perspective of learning “entails use of a holistic qualitative methodology which sheds light on learning processes as they occur in interactive settings” (p.53). Because the purpose of this study was to understand and interpret social interactions as they occur in the online interactions through the lens of sociocultural theory, a qualitative approach was required. Indeed, the purpose was to describe the sociolinguistic elements that would be put into display in the exchanges and to find out if the way NS used these elements would have an effect on the NNS’ sociolinguistic competence. In addition to the practice of sociolinguistic elements, it was important to describe the type of relations that would develop between members of a group and to see if these relations facilitated the development of sociolinguistic competence. Qualitative research allowed focusing on the social interactions as they occurred in the exchange in the goal of understanding if and how students learned.

One broad definition of qualitative research is "any kind of research that produces findings not arrived at by means of statistical procedures or other means of quantification" (Strauss and Corbin, 1990, p. 17). Qualitative research is also described as using a naturalistic approach that seeks to understand social phenomenon in context-specific settings (Lichtman, 2006). Therefore, qualitative research is often referred to as naturalistic inquiry. As Patton (1992) explains, "Naturalistic inquiry is [...] contrasted to experimental research where the investigator attempts to completely control the condition of the study" (p. 42). In the literature, qualitative research is used as an umbrella terms that often refers to a way of seeing the world but is also associated with methodologies (Litchman, 2006). Lincoln and Guba (1985), often referred to in educational research for their important work on naturalistic inquiry, use the term

“constructivism” to describe a way of seeing the world where realities are socially constructed. This view is opposed to the concept of “positivism” where there is only one reality that is constructed by experimental methods and quantitative measures to test hypothetical generalizations. Qualitative research is also associated with methodologies and with types of research traditions such as ethnography, grounded theory and case-study.

Although the literature on qualitative research in education is very broad and framed in many ways, some prominent characteristics of qualitative research can be found. The list that follows represents a synthesis of the characteristics of qualitative research as described by Lichtman (2006) and Lodico, Spaulding and Voegtle (2006). Qualitative research:

- aims at attempting to describe, understand and interpret things as they occurred rather than constructing artificial situations of experiments;
- is dynamic and does not follow one particular way of doing something;
- uses inductive thinking, starting from the particular to produce more general observations;
- is holistic in the goal of providing a thorough description of the situation observed using multiple sources of evidence;
- requires the researcher to play a pivotal role as interpretations are based on his experience and knowledge;
- involves in depth-study of a nonrandom group of participants chosen on whether they have information vital to the question being asked;
- is characterized by words rather than numbers;
- is not linear as hypothesis are formed after the researcher begins data collection and are modified through the study.

It is the nature of the research questions and the type of investigation undertaken that lead to a qualitative approach in the data collection and analysis of data in this research study. Indeed, the idea was to describe the online interactions as they occurred between participants with minimal interventions besides providing students with topics of discussion and general objectives. This decision was based on previous research that has shown that the development of sociolinguistic competence of L2 learners is facilitated by informal face-to-face interactions with native speakers. So, the idea was to observe if online discussions with native speakers would have a similar effect on the sociolinguistic competence of NNS.

Although I was aware of the many traditional approaches to qualitative inquiry, it is the nature of the research questions that drove my decisions about which methodology to use more than the desire to follow one of these approaches. Using sociocultural theory as lens required using a methodology that allowed observing students' interactions in the online environment while trying to understand how sociolinguistic competence could develop. In addition, a framework describing sociolinguistic competence which could guide my observations was needed. So the choice of methodology was influenced by the theory of learning chosen to look at the data as well as by the research questions.

The type of approach used has been described as a "generic approach" to do qualitative research. According to Merriam (1998), generic qualitative studies are among the most common forms of qualitative research in the field of education, however, it is not until recently, that it has been articulated in these terms. According to Caelli, Ray and Mill (2003) educational researchers using a generic approach

characteristically draw from concepts, models, and theories in education, developmental or cognitive psychology, or from sociology, which provide the framework for the studies.

Analysis of data uses concepts from the theoretical framework and generally results in identification of recurring patterns, categories, or factors that cut through the data and help to further delineate the theoretical frame (p. 6).

Caelli and her colleagues acknowledge the fact that there is more than one single type of methodology used by researchers engaging in this type of research but argue for the need of more discussion on how to do this type of research well. They suggest four basic requirements for good generic qualitative research: noting the researchers' position, distinguishing method and methodology, making explicit the approach to rigor, and identifying the researchers' analytic lens.

In regards to the first criteria, the reasoning that brought the research questions, the assumptions towards the topic of interest, and the congruence between the research questions and the approach chosen should be clearly identified. Methods and methodology should be distinguished. The approach which guided methodological choices should be discussed as well as connected to the type of knowledge to be constructed. Regarding approach to rigor, Caelli and her colleagues explain that qualitative researchers need to: “ 1) articulate a knowledgeable, theoretically informed choice regarding their approach to rigor, and 2) select an approach that is philosophically and methodologically congruent with their inquiry” (p. 15). They add that investigators must ensure rigor “by adhering to principles that are congruent with the assumptions of the approach they are using” (p. 16).

This research study showed that the research choices made were informed by a set of assumptions and beliefs about SLA and about how language is learned. Accounts, descriptions and results were explained in relation to these methodological assumptions in the overall of the study. Other methodological decisions that were taken concerned the groups that were observed.

There were fourteen groups of three to five students which were composed of a mix of NS and NNS. The groups that met for the required amount of time and where all the members met regularly were chosen for the analysis. In total, seven groups were chosen. “Purposeful sampling” is the dominant strategy in qualitative research as it seeks cases containing rich information to be studied in depth (Patton, 1990). This decision was justified by the fact that to be able to learn from each other, participants had to interact for a minimum amount of time. This means that half of the groups did not meet for the required amount of time or their members did not participate equally. Because the intention of this research is to inform educational practice, factors that may have influenced the full participation of students are discussed throughout this paper and in the conclusion.

#### *A. Participants*

The participants in this study were twenty-four students from a Canadian university in British Columbia and twenty-nine students from a Canadian college in Quebec. The teachers from both groups made contact in the previous months of the project to decide on pedagogical activities that would reach the learning objectives of their respective course. Both teachers agreed on trying to reach the objectives related to culture and chose topics of discussion related to this aspect. Because the contact between these two groups was to be done in writing, it was expected that linguistic objectives would also be reached.

Participants in Quebec were enrolled in a course on French literature and culture. This college is situated in a major Canadian city and is characterized by its multicultural diversity. This course is designed for French speakers. However, results from the post-study questionnaire revealed that a little less than half of students considered themselves Francophones. The other half of the students answered that they had been living in Quebec for a period between three

years and seventeen years. Despite the heterogeneity of this group, they are called native speakers of French in this study because the course they were taken required a native-like level of French and because their instructor consider them to be native speakers.

The participants in British Columbia were enrolled in an intermediate French as L2 class that focused on the development of oral and written skills and on culture. Most of these students had studied French as a L2 through the Core French program in elementary and high school, but three students came from the immersion program and one from an international school. For most of the students, this was their second French course at the university level. More than half of the students had been to a French speaking area or community before (65%). Some had visited a French speaking place for a few days to two weeks (38%) and others had spent a more significant time from three to five weeks or for a few weeks more than once (68%). Half of the students answered that they were never or rarely using French outside the classroom. The other half answered that they were speaking French occasionally with friends and family and with customers. This group was also composed of students with various cultural backgrounds. 60% of them declared having English as a first language and 45% declared speaking English only normally at home. The other languages spoken at home were: Mandarin (3), Cantonese (2), Cantonese/English (2), Gujarati/English (1), Korean (1), English/Arabic (1), and Spanish (1).

### *B. Setting*

During the spring semester of 2007, these two groups of students met for nine weeks online to discuss cultural topics. A course management system, Moodle, was used to create the online environment where students could communicate. The design of Moodle is based on socio-constructivist pedagogy that allows for collaborative interaction among students (Brandl, 2005). On this web platform, students were able to send and receive e-mail, enter an assigned chat-room

and participate in a discussion forum that included all the participants. Also, students were able to access information on the topics of discussion, suggest texts or other sources that they found useful to the ongoing discussions. Moodle was chosen for this project because it allowed students to share ideas and allowed for the collection of students' writing.

Each student was required to participate in a minimum of six chat sessions (synchronous CMC) and three forums (asynchronous CMC). For the online chat, students were put randomly in groups of three to five students and the forum was arranged to include all of the students from both groups. For the chat sessions, students in the same group had to e-mail each other and decide on a time to meet outside of regular class hours. They could link up to the system from anywhere using a computer with access to the Internet. The chat sessions were generally made up of two students from Quebec and two students from British Columbia but because there were more NS students, some groups were composed of three NS and two NNS.

### *C. Structure and Activities*

The learning objectives for both groups of students participating in the project were as follows:

- 1) to create bonds between both communities;
- 2) discover both their own and the other's culture;
- 3) discuss culture in general and expand their horizons;
- 4) improve their written and cultural competence;
- 5) and familiarize themselves with the different tools for online discussions.

Students from both groups were informed of the learning objectives in the consent form, and verbally by their respective instructor. Because the exchange was in French, there was a specific objective for students in British Columbia. These learners were expected to increase

their sociolinguistic competence in particular. It was expected that this competence would developed naturally by providing the NNS with the opportunity to interact with the target language and culture in a natural interaction set in a virtual environment.

Both instructors and I agreed on three topics to be discussed during the nine weeks: 1) what defines me; 2) travelling and what it brings to people; 3) multiculturalism. The topics were related to cultural themes that were to be explored in their respective class. Topics were chosen carefully to insure that they would instigate lively discussions and because they integrated well with the readings and objectives of the courses. Students had to meet weekly for a minimum period of thirty minutes to discuss the topic in their respective chat-rooms. They had to discuss the same topic over two weeks with series of questions provided each week to guide their discussions (see Appendix A for topics and questions). In the third week, they had to write a paragraph on the topic and to post it in the collective group forum. So, over the period of nine weeks, they were supposed to participate in six chats and three forums. Both classes were informed of the sequence of activities by their instructor and I also visited the class in British Columbia to make sure students understood the objectives and organisation of the activities. All participants received a form (Appendix B) to help them with the organization. Both instructors agreed to give marks for students' participation in the activities.

The decision of having participants use two different mediums was made with the instructors and met the objectives of their respective course. The chat was supposed to allow students to share their ideas, their experiences, and to further their reflection on the topic. This first step was aimed at preparing them to write a personal piece on the topic to be shared with others in the group forum. These two activities were also planned to expose NNS to various registers. Indeed, it was expected that the NS would naturally adapt their register to the medium,

using an informal register for the chat and a more formal register for the forum. As a consequence, the NNS would be exposed to two registers and would have the opportunity to draw a parallel between both contexts of communication. This exposure was expected to develop their sensitivity to various registers and perhaps lead to the use of new linguistic forms in their discourse. This aspect was not explained to students explicitly to avoid influencing them in their choice of registers.

Students were instructed to read the three questions of the week before meeting online with their group. Questions were posted on the Moodle webpage and students were asked to use them to guide their discussion. Each student was requested to participate in the discussion. After two weeks of chatting on a topic, students were asked to write a paragraph of at least one hundred words on the discussed topic. They had to post their paragraph on the forum of the Moodle webpage. Students were not required to read each other's paragraph but it was assumed that they would be interested in doing so. This behaviour was also encouraged by the Moodle system that forwarded an e-mail to students every time there was a new posting on the forum.

#### *D. Data Collection*

The data consisted of transcripts of chat sessions, forum entries, pre and post study questionnaires, and interviews. The Moodle system kept track of all the interactions made by students in a chronological order with the name and time for each contribution. All of the interactions were saved digitally.

At the beginning of the semester, a questionnaire was distributed to the students in British Columbia (see Appendix C). This questionnaire was designed to collect information on their first language, language use at home, and on the use of French outside the classroom. At the end of the project, the same group completed a post-study questionnaire. Twenty students filled in the

pre-study questionnaire and nineteen students the post-study questionnaire. The post-study questionnaire contained three open-ended questions on their perceptions about the exchange (see Appendix D). Finally, the NNS were interviewed after the project. Nineteen students came to the interview. The one on one interview was designed to bring out the opinions and attitudes of students towards this specific language practice. The questions asked in their interviews are presented in Appendix D. The interviews of an average length of five minutes were recorded digitally and transcribed. Seventeen students in Quebec filled in a post-study questionnaire designed to collect information on their language knowledge and practice (Appendix E).

Both groups of students were informed of the nature of the study and their rights as participants before starting the online exchange. Each student signed a consent form to participate in the study. This form described, among other things, the objectives of the study, the conditions of their participation, and their right to withdraw at any time (Appendix F).

### *E. Data Analysis*

This study addressed principally the potential of a CMC intercultural exchange for the development of the sociolinguistic competence of L2 learners. Along with this main issue, this study aimed at providing a description of this language practice and how it can support the development of the sociolinguistic competence. Therefore, the research analysis was divided into two main parts. The first section describes the analysis of the sociolinguistic aspect. The second section describes the analysis of this language practice.

#### *1. Analysis of the Sociolinguistic Aspect of the Intercultural CMC Exchange*

This part of the study consisted of a qualitative analysis of the transcripts to study the potential of the CMC intercultural exchange for the development of the sociolinguistic

competence of the NNS. It was divided in three main parts. The first part focused on finding whether the discourse of the participants in the online chat and in the forum displayed elements of sociolinguistic competence. The second part focused on identifying differences in the use of the sociolinguistic elements by NS and NNS. It was assumed that the NS would use the appropriate sociolinguistic elements in each specific context and that different ways of using these elements by NNS would point out a lack of development of their sociolinguistic competence. This way of measuring the competence was discussed in chapter 2. Finally, the third section focused on looking for changes over time in the use of specific sociolinguistic elements in the discourse of NNS specifically with the objective of finding sociolinguistic development.

The organization of the qualitative analysis of the sociolinguistic elements with each technology addresses the following research question.

#### Question One

Did the intercultural CMC exchange provide the conditions necessary for the development of the sociolinguistic competence of non-native speakers?

Along with this main research question, two sub-questions were also investigated:

- a. What were the differences and similarities in the use of sociolinguistic elements for native speakers and non-native speakers involved in the intercultural CMC exchange?
- b. Was there evidence of sociolinguistic competence development for the non-native speakers involved in the intercultural CMC exchange?

*The Common European Framework Reference for Languages (CEFR)* was chosen to investigate the sociolinguistic competence aspect of the intercultural CMC exchange because it has become a key reference document and a valuable tool for all who are directly involved in language teaching. In addition, it provides the most detailed description of the elements included in the sociolinguistic competence when compared to other frameworks such as the *Standards for*

*Foreign Language Learning in the 21st Century* (American Council on the Teaching of Foreign Languages, 1999) or with the core French provincial language curriculum in British Columbia (British Columbia Ministry of Education, 2001). The framework was used as a guide to describe the discourse used by the participants in the intercultural CMC exchange regarding sociolinguistic elements rather than as an evaluation tool. It was hoped that a new model would emerge from this study that would be useful for teachers wanting to develop the sociolinguistic competence of learners by doing a similar exchange. Figure 1 illustrates the organization of the competences included in the framework and shows how the sociolinguistic competence integrated with the others.

Figure 1 *The Learner's Competences* (Council of Europe, 2001)

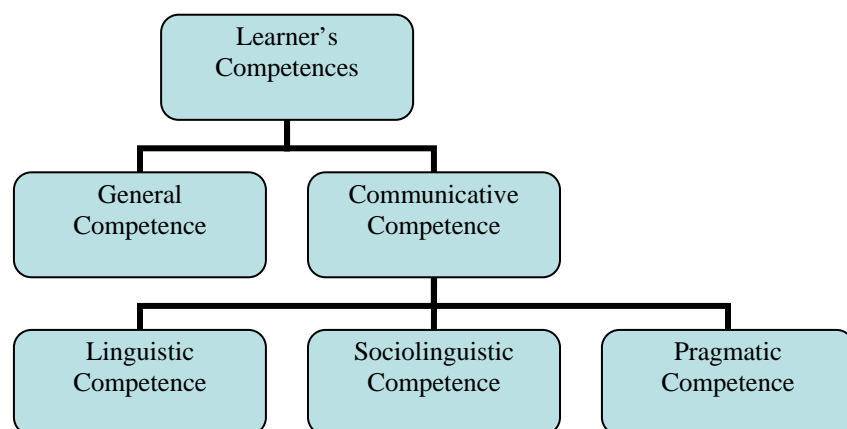

The communicative competence is described as containing three components: linguistic competence, sociolinguistic competence and pragmatic competence. Figure 2 gives an overview of the categories included in the sociolinguistic competence as described in the CEFRL.

Figure 2 *Sociolinguistic Competence (Council of Europe, 2001)*

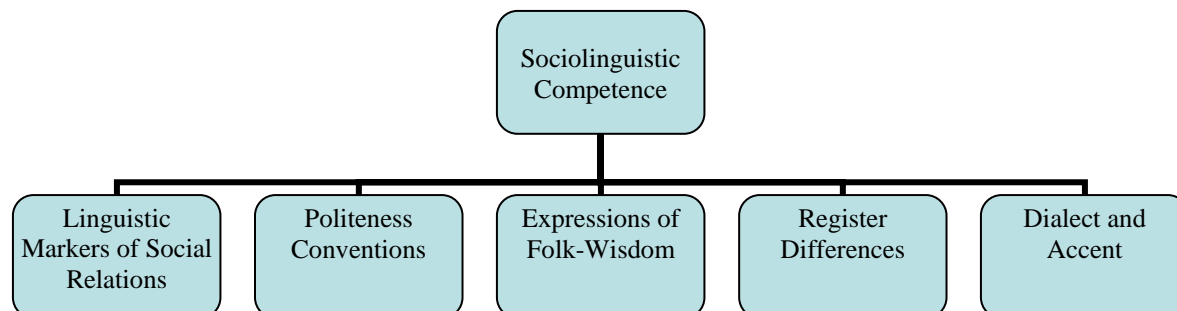

In this research study, the categories described in Figure 2 were used to analyze the discourse of the participants. The last category, dialect and accent, was not used because it is generally concerned with the oral form of language.

First, using the categories above, I identified and classified excerpts containing sociolinguistic elements in the transcripts of the interactions with the objective of obtaining a general description of the use of sociolinguistic elements by both groups in both mediums. For example, starting with the first category “linguistic markers of social relations” which includes greetings on arrival, all the transcripts were analyzed to identify the greetings on arrival chosen by each group. This was done with each category presented above. Because the CEFRL is not specific to CMC, this first analysis was expected to provide a description of the sociolinguistic elements in play with each CMC tool and what this type of communication can bring to language learners compared to face-to-face communication.

Secondly, differences in the use of sociolinguistics elements by NS and NNS were identified. For example, words used for greetings on arrival by NS were compared with the ones used by NNS. The assumption was that NS would appropriately use these elements, and that a

different use by NNS would point out to a lack in their sociolinguistic competence. This analysis was also meant to provide a description of the elements that were used in a similar way by both groups.

Finally, the elements used differently by the NNS were tracked in the overall transcripts in the objective of finding changes. For example, if a difference was noticed in the use of expletives between NS and NNS, I looked for changes in the NNS' choice of words over the duration of the exchange.

## *2. Analysis of Language Practice*

This part of the analysis was concerned with the answers on the post-study questionnaire and interviews regarding the characteristics of the language practice fostered by the intercultural CMC exchange. The organization of this qualitative analysis addresses the next research question.

### Question Two

What characteristics of the intercultural CMC exchange as a language practice supported the development of the sociolinguistic competence?

For this analysis, the three C's of qualitative analysis as described by Lichtman (2006): 1) Coding; 2) Categorization; and 3) Concepts, as well as the six steps she describes in order to make sense of the data, were followed. Before starting with step 1, several readings of the data were made in order to decide on the initial coding. Table 2 gives details on the steps followed for this analysis.

Table 2 *Steps for Analysis of Language Practice*

---

Step 1	Initial coding according to aspects that emerged from the data: answers related to 1) language practice; 2) contact with NS; and 3) characteristics of online tools
Step 2	Revaluation of the initial coding and changes based on rereading and reflection
Step 3	Initial lists of categories
Step 4	Revaluation of list and changes
Step 5	Reassessment of sub-categories and categories
Step 6	Move from categories to themes

---

The whole process of this qualitative analysis allowed for the emergence of themes for each of the key aspects. Finally, the themes were discussed in relation to the research question. In addition to the answers to the questionnaires and the interviews, further observations were made in the discourse used by the participants to complete the answers to the second research question.

In an attempt to understand better if and how language learners were supported in the interactions, I looked for instances of “negotiation of meaning”. Negotiation of meaning refers to a communicative act in which two or more participants “negotiate” to resolve communication breakdowns and establish mutual understanding. This was a starting point to find out if there were communication breakdowns, and how they were resolved by participants. Previous research has shown that written CMC such as online chat fosters negotiation of meaning (Lamy &

Goodfellow, 1999; Pellettieri, 2000; Toyoda & Harrison, 2002). Table 3 shows examples of type of “negotiation on meaning” moves based on the work of Long (1983).

Table 3 *Examples of Negotiation of Meaning Moves*

---

Self-Repetitions

*It was cold inside, I mean, it was cold outside.*

Comprehension checks

*Do you understand?*

Confirmation checks

*Did you mean/say “X”?*

Clarification requests

*What do you mean by “X”?*

---

The objective of this part of the analysis was to find out whether this intercultural exchange, with its specific characteristics, fostered negotiation of meaning moves from the participants. Moreover, it was the intention of the research to find out if and how NNS were supported in the acquisition of new linguistic forms that could lead to the development of sociolinguistic competence.

In addition, I looked at the type of personal contact fostered by the intercultural CMC exchange. More specifically, the idea was to find out if students were able to exchange ideas on the topic and if they were able to express their opinions freely. So, the themes that emerged from the answers on the questionnaires and in the interviews were complemented by an analysis of the chat discussions. The objective was to give a description of the type of contact afforded by the CMC exchange and how this contact supported the development of the sociolinguistic competence.

### *F. Conclusion*

This chapter has reviewed the purpose of the present study and laid out the format and methodological considerations of the research. It has described the pedagogical goals of the study, the participants and the structure of the interactions. The method for the collection of data was explained as well as the approach used for the analysis of the data. The research questions were reviewed and examples were provided to support the methodological approach. Figure 3 gives a review of the analysis.

Figure 3 *Review of Analysis*

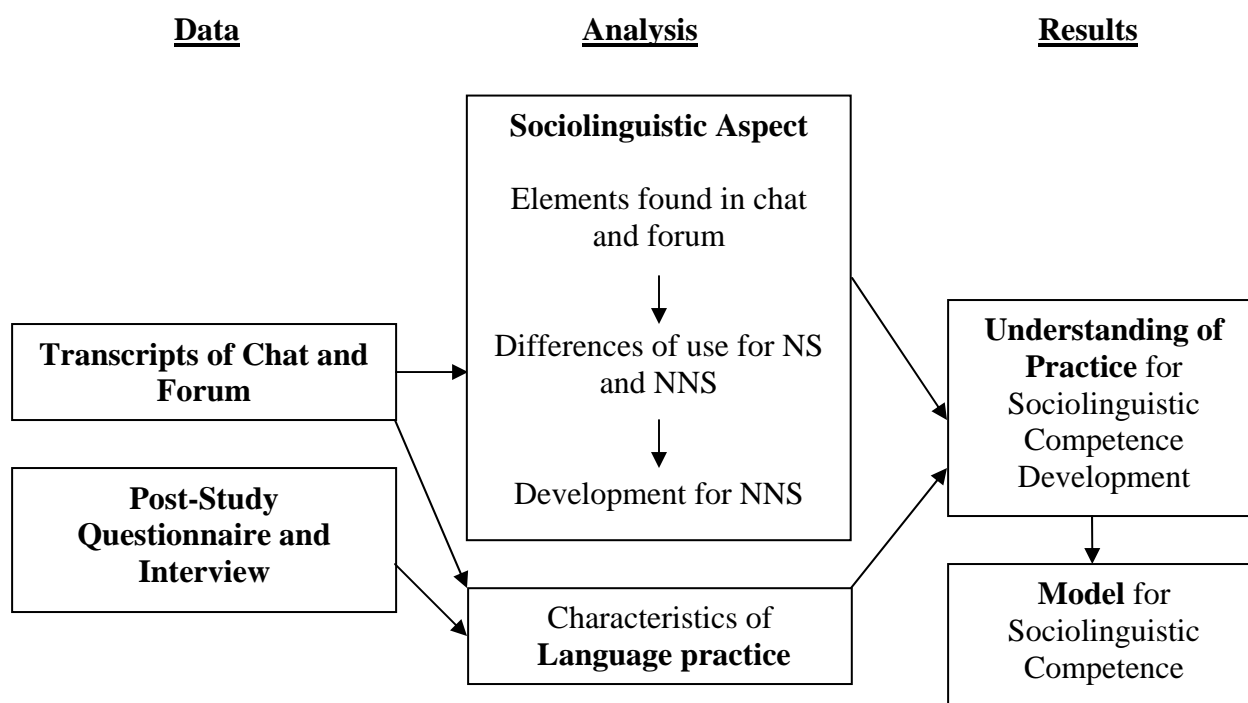

In all of the extracts chosen to illustrate the analysis in chapter 4 and 5, none of the writing has been corrected and the names have been changed to protect the identity of the participants. It is hoped that this qualitative analysis will lead to the elaboration of an adapted model for the teaching of this competence with CMC and to recommendations for best practice.

#### IV. Results: Sociolinguistic Competence

In this chapter, I analyzed the potential of an intercultural CMC exchange as a means for the development of sociolinguistic competence. This competence is recognized in the CEFRL as the one concerned with the knowledge and skills required to deal with the social dimensions of language use. Hence, the results presented in this chapter aimed at finding out if the characteristics of the online interaction provided access to the social dimensions of language use and therefore supported the development of sociolinguistic competence.

Therefore, the results presented in this chapter are related to the sociolinguistic aspect. The categories described under the sociolinguistic competence in the CEFRL were used to answer the first research question:

##### Question One

Did the intercultural CMC exchange provide the conditions necessary for the development of the sociolinguistic competence of non-native speakers?

Along with this main research question, two sub-questions were also investigated:

- a. What were the differences and similarities in the use of sociolinguistic elements for native speakers and non-native speakers involved in the intercultural CMC exchange?
- b. Was there evidence of sociolinguistic competence development for the non-native speakers involved in the intercultural CMC exchange?

In order to answer the first research question, a qualitative analysis of the transcripts of the interactions was conducted. The categories described in the CEFRL under sociolinguistic competence were used to see if online chat and forum discussion allowed for the display of the elements in each category. To answer the first sub-question, differences and similarities in the use of sociolinguistic elements for native speakers and non-native speaker were identified. Finally, to answer the second sub-question, changes in the use of these elements by NNS were

identified. The next section presents the results of the qualitative analysis of the transcripts of the sociolinguistic elements found in the online chat and in the forum.

### *A. Sociolinguistic Elements in Online Chat and Forum*

The extracts chosen to illustrate the results have been left as students wrote them. Because the discourse displayed in both these medium was quite different, they were analyzed separately. The results of the analysis for the chat session are presented first.

#### *1. Linguistic Markers of Social Relations*

The first category analyzed was “linguistic markers of social relation”. Figure 4 reviews the elements of this category.

Figure 4 *Linguistic Markers of Social Relations (Council of Europe, 2001)*

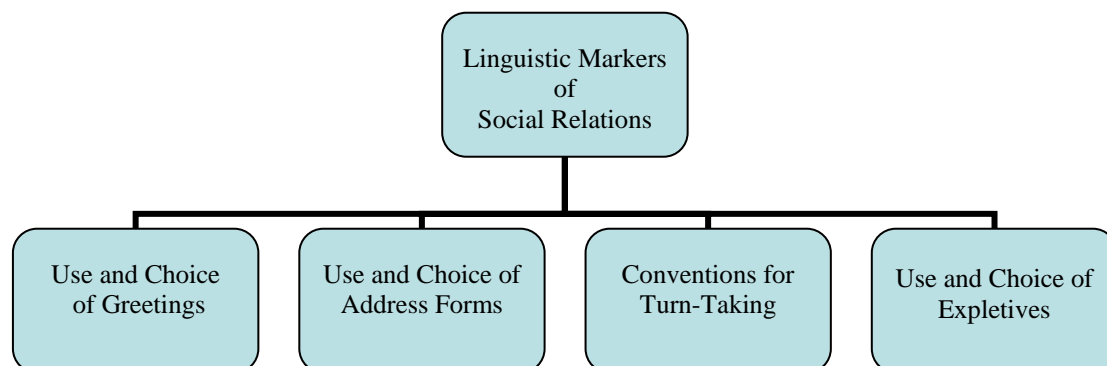

In each of the transcripts of the online chat analyzed, the majority of the participants greet each other on arrival, before starting to discuss the topic. Two different ways to greet were observed amongst participants. Participants either wrote one general greeting for everyone in the online chat-room or they took several turns to greet everyone individually. Both ways of greetings were found in comparable numbers. There were three different words used for

greetings: “bonjour”, “allo” and “salut”. The first word is generally qualified as more formal than the others. Salutations were usually followed by asking each other about their well-being. In French, as in English, it is polite to ask “Comment ça va?” meaning “How are you” when meeting someone before starting a conversation. A more colloquial way to ask about the well-being, “Ça va?” a shorter version of “Comment ça va?” was used by some participants. Greetings on leave-taking were also used by most of the participants at the end of the discussions. Again, participants took one turn to greet everyone at the same time or several turns to greet everyone individually. The extract 1 shows a typical way of greetings on arrival by participants. The students marked with an asterisk (\*) represent the NNS.

(1) Chat-room 15, Chat 5

N: Salut, ça va?  
*Hi, how are you?*

S\*: Bien, vous?  
*Well, and you?*

N: Pas pire, mon dos me fait mal. Mais apart de ça, je suis bien correct.  
Not too bad, my back is hurting me. But besides that, I am well.

E: ca va  
*Fine*

S\*: Bonjour Est  
*Hi Est*

E: on avait dit a dix heures, n'est-ce pas?  
*we said ten o'clock, didn't we?*

Sa\*: bonjour!  
*hi!*

The most common words chosen on leave-taking were “à la prochaine”, “bye”, “bye-bye” and “au revoir”. However, there was more diversity on the choice of words for leave-taking than for greetings on arrival. Extract 2 shows a typical way of finishing a chat.

(2) Chat-room 8, Chat 2

M\*: parfait! merci! a la prochaine!!!  
*perfect! thank you! see you next time!*

T\*: Parfait! Aujourd'hui a bien marche pour moi cars ma famille de danemark est ici et je garde ma niece demains.  
*Perfect! Today worked well for me because my family from Denmark is here and I am babysitting my niece tomorrow.*

A: ok a la prochaine!  
*ok see you next time!*

K: Oh ok! Bon alors bonne soirée!  
*Oh ok! So have a good night!*

K: Bye bye!

T\*: A la semaine prochaine. Merci Marine.  
See you next week. Thank you Marine.

A: bye!

M\*: au revior!!

In their use and choice of address forms, participants called each other by their first names and used the pronoun “tu” when talking to someone in particular. Even if the students did not know each other at first, the fact that they were all students in a similar age group seemed to have been enough to help them choose the informal pronoun and call each others by their first names. In general, participants used the plural pronoun “vous” when their questions and comments were addressed to the group, and the pronoun “tu” when they addressed one person in particular in the group. In this specific context, the use of “vous” to show respect or maintain a

certain distance with a participant was not appropriate. However, this first observation showed that the context of communication forced the NNS to choose between the “tu” and plural “vous”.

The extract below shows how the participants chose between both pronouns (pronouns are in bold).

(3) Chat-room 1, Chat 3

D\*: oui, je suis alle a L.A come 7 ou 8 fois  
*yes, I went to L.A around 7 or 8 times*

S: **tu** as de la famille là-bas?  
***you** have family overt there?*

D\*: non, je suis alle avec ma companie de danse  
*no, I went with my danse group*

C: c'est vrai **tu** nous avait dit que **tu** dansais  
*it's true, **you** told us that **you** were dancing*

D\*: oui, mais pas beaucoup maintenant, j'ai trop a faire avec mes etudes  
*yes, but not a lot now, I have too much to do with my studies*

C: ah d'accord  
*ah all right*

D\*: c'est vraiment different d'alle visiter les place quand tu es dans un grand group comme ca, j'aimerais mieux quand c'est avec mes amis ou defois ma famille  
*it is really different to visit places when you are in a big group like that, I would prefer with my friends or my family sometimes*

S: Oui, je comprends.  
*Yes, I understand*

S: Alors, quel endroit **vous** avez particulièrement aimé voyager?  
*So, which places did **you** particularly like to travel to?*

D\*: j'aime Disneyland beaucoup, et las vegas et hawii  
*I like Disneyland a lot, and Las vegas et Hawaii*

C: personnellement j'ai beaucoup aimé le Sud de la France car il y fait chaud et ils ont une belle culture  
*Personally, I really liked South of France because it is warm there and they have a nice culture*

All participants seemed to be able to respect turn-taking conventions. According to Cook (1989), “Turn-taking mechanisms, the way in which speakers hold or pass the floor, vary between cultures and between languages [...]. These mechanisms cannot simply be lifted from one society (and thus from one language via literal translation) to another” (p. 52).

The conventions for turn-taking in synchronous CMC are highly context sensitive, as described by Negretti (1999). Most of the participants wrote when they had something to say so the turns rarely appeared on the screen in a logical sequence. There were plenty of disrupted sequences, but participants did not make any comments that showed frustration towards delays in answers and/or other sequences of interactions beginning at the same time. Other characteristics of turn-taking described by Negretti (1999) include strategies such as turn-giving and addressing different interlocutors in the same turn. These two strategies are showed in example 4 and 5 below.

(4) Chat-room 3, Chat 3

C\*: Sabina, tu vas aller au concert de les Police?  
*Sabina, are you going to The Police's concert?*

(5) Chat-room 3, Chat 3

S\*: Bonne chance! .....salut Erica  
*Good luck!.... Bye Erica*

Sometimes, students announced their turn when they started to discuss the topic of the week, as shown in the following example:

(6) Chat-room 3, Chat 3

J: Je commence  
*I am starting*

Besides these few strategies, participants joined at any time when they had something to add to the on-going discussion. These characteristics of turn-taking in chat differ greatly from turn-taking in face-to-face communication. Indeed, in a face-to-face conversation, a listener may rely on cues such as intonation, body motion, typical expressions, etc. (Coulthard, 1977). In this study, the chat-room seemed to dictate how turns were taken and the way interlocutors were used to take turn in their own language didn't have any influence. For L2 learners, this characteristic may prevent any awkward turn management that could occur in a face-to-face conversation. However, this specific CMC environment did not foster the development of strategic competence that could be applied to a face-to-face conversation.

The discourse of the participants displayed various expletives. Expletives, in the CEFRL, refer to an exclamatory word or phrase such as “Dear! Dear! My God! Bloody Hell!”. These expressions do not add meaning to a sentence but they rather show feelings such as irritation, frustration, admiration, and enthusiasm. In the exchange, participants used them to show surprise admiration, and enthusiasm.

(7) Chat-room 12, Chat 4

Ma\*: je suis alle au disneyland ET disneyworld (j'aime le deux)  
*I went to Disneyland AND Disneyworld (I like both)*

Mi: **oh wow**..alors quels pays vous avez visite?  
*Oh wow... So which countries did you visit?*

In this extract, the use of “oh wow” shows that the participant is impressed by what the other is saying, which probably encouraged the latter to relate other experiences. Within groups, all members either used expletives frequently or very little. Groups using many expletives might have had participants that are more expressive than others or participants more interested in the

discussion. Groups that used a lot of expletives also used exclamation marks to accompany other phrases such as greetings on arrival and on leaving such as in this extract:

(8) Chat-room 6, Chat 4

F: Salut Mary!

M\*: Bonjour, Fiona!

These exclamations were used for greetings on arrival, and seemed to show that the participants are enthusiastic about their meeting and the upcoming discussion. In the context of online chat interactions, exclamation marks are rather important in the absence of intonation that can be used in an oral conversation to emphasize the message. Moreover, because of its interactive nature, exclamation marks are used more frequently in online chat than in normal writing to indicate assertions, expressions of surprise, admiration and happiness (Negretti, 1999).

Participants, both NS and NNS used a lot of “ha ha!” in their discourse. According to Bell (2005), laughter can be seen as indexing humour but can also indicate surprise, embarrassment and nervousness. In the exchange, participants used laughter to react to what was said as shown in this extract.

(9) Chat-room 8, Chat 1

A: C'est vrai que Disneyworld rend tout le monde jeune!  
*It's true that Disneyworld makes everyone young!*

M\*: hahaha

They also used it to laugh at themselves as shown in this extract.

(10) Chat-room 8, Chat 2

M\*: ok, j'aimerais voyager en australie... parce que j'aimerais apprendre comme faire le surf... et j'aimerais connaître un homme tres beau. hahaha.  
*ok, I would like to travel to Australia... because I would like to learn how to surf... and I would like to meet a very handsome man. hahaha.*

Participants also used it to avoid face-threatening situations and to avoid any discomfort.

(11) Chat-room 8, Chat 3

M\*: et vous, Anne et Kara?  
*And you, Anne and Kara?*

K: quoi?  
What?

M\*: ah, tu as répondu. pardonne-moi.  
*Ah, you already answered, I am sorry.*

A: ha ha c'est correct  
*ha ha it's o.k.*

K: haha ça va!  
*haha no problem!*

“Unlike spoken discourse, where pitch, smiles, laughter and other cues are often employed sub-consciously, people engaged in written CMC must put all their ideas and actions into words if they want to share them with their partners” (Kötter, 2003, p.148). Kötter talks about “deliberate actions”. The examples provided above show that participants in both groups added cues to their message to insure that the interlocutors understood all the subtlety of their message.

According to Tarone (2000), language and humour may aid in the development of sociolinguistic competence by allowing learners to experiment with different voices, and by destabilizing the interlanguage system. The interlanguage, that is, the language system that learners have build in their L2, may be destabilized when learners play with words by requiring creative forces and demanding innovation. This process may trigger language learning. Using humour and language play requires knowing some rules about how to engage in the “joking activity” and also understanding its social meaning in the target culture. It seems that these

elements should be included in a model of sociolinguistic competence. Therefore, they will be included in the new model suggested in the conclusion of this paper.

## 2. Politeness Conventions

The second category analyzed was “politeness conventions”. Figure 5 reviews the elements of this category.

Figure 5 *Politeness Conventions (Council of Europe, 2001)*

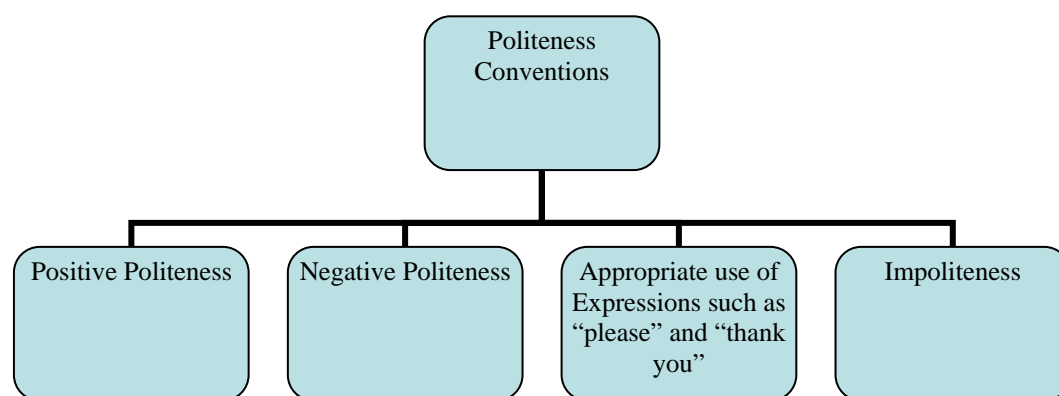

In the groups analyzed, most of the participants expressed “positive politeness” at some point in the online chat sessions. The typical ways of expressing positive politeness were either by showing interest in one’s well-being, which was done mostly in the greetings on arrival and departure, by expressing admiration towards someone’s experience, and by expressing affection and gratitude towards one another. Extract 12 is an example of a participant showing interest in someone’s well-being and expressing admiration towards someone’s experience. The NS (J) explains why he had difficulty finding time to meet online with the others.

(12) Chat-room 3 – Chat 3

S\*: Bonjour Joel  
*Hi Joel*

- J:     allo!!  
       *Allo!*
- J:     sa va ???  
       *How are you?*
- S\*:    finaleme! oui, ca va...et vous?  
       *Finally! Yes, I am well... and you?*
- J:     très bien!!...ouais je sais je suis désolé sa m'a pris du temps avant de pouvoir me libérer  
       mais à cause de mes compétitions et tout j'ai un horaire chargé  
       *Very well! Yes, I know, I am sorry that it took me some time before being able to be  
       available but because of my competitions and all, I have a full schedule.*
- S\*:    **Je comprends. Comment s'est passé tes compétitions?**  
       *I understand. How did your competitions go?*
- J:     Bien .....je suis maintenant classé dans le top 5 au canada  
       *Well... I am now classified top 5 in Canada*
- S\*:    **Au oui?!?!? C'est fantastique.** Dans quel épreuve?  
       *Ah yeah! It's fantastic. In which event?*
- J:     200 mètres  
       *200 meters*

In the following extract, one participant is showing affection to the others.

(13) Chat-room 15, chat 5

E:     **wow, c'était vraiment agreable de vous parler.**  
       *Wow, it was so nice talking to you.*

In regards to “negative politeness”, participants have successfully avoided placing each other in face-threatening situations, that is to say, the participants didn’t show dogmatism, use direct orders or adopt any other behavior that would have create embarrassing situations. They consistently showed respect and openness towards each others’ ideas. However, misunderstandings did occur and forced participants to use instances of “negative politeness” to apologize. In the following extract, one of the participants apologized for asking a question for which the answer is obvious.

(14) Chat-room 12, chat 4

B\*: je suis de la Jamaïque, et j'ai habité là.  
*I am from Jamaica and I lived there.*

M\*: a oui? est ce que tu es jamaïcaine?  
*Ah yeah? Are you Jamaican?*

M\*: ok excuse ma question a pa de rapport  
*Sorry, my question is not relevant*

Negative politeness was also expressed when a participant was late and apologized for entering the room in the middle of a discussion.

(15) Chat-room 14, Chat 5

Sh: Salut! Désolée du retard, j'ai dû recommencer mon ordi car il ne fonctionnait pas bien.  
*Hi! Sorry for the delay, I had to restart my computer because it didn't work well.*

Negative politeness was also expressed by participants in the use of hedges. The term “hedge” refers to the strategies used by a speaker to avoid making absolute statements, or to take a certain distance towards a statement (Salager-Meyer, 2002). Participants added hedges to their discourse with introductory phrases such as “I think”, “I believe”, tag questions and words such as “perhaps”, “often” and “generally”. Extracts 16, 17 and 18, show different ways used by participants to add hedges to their discourse.

(16) Chat-room 14, Chat 5

Sh: **Peut-être** que la culture au Canada en général est différentes de celle du Québec  
*Perhaps that the culture in Canada in general is different than the one in Quebec*

(17) Chat-room 6, Chat 6

F: De toute façon, **je crois** qu'il est impossible pour une nation d'être totalement tolérante  
*Anyway, I believe that it is impossible for one nation to be totally tolerant.*

(18) Chat-room 15, Chat 6

Sa\*: **Je pense** que c'est très bon d'avoir deux cultures en soi même parce que tu peux identifier avec plusieurs cultures pas juste une

*I think that it is very good to have two cultures in one self because you can identify with more than one culture not just one*

Participants used “je pense que” meaning “I think that” often in their discourse. This expression is used to modulate our speech acts and is a way of showing that we accept the others’ opinions and ideas and that we are able to coexist with others (Salager-Meyer, 2002). The fact that this expression appeared a lot in the discourse of the participants shows their desire and their ability to express their openness towards each other’s ideas and their efforts to maintain an appropriate atmosphere for discussion by not making absolute statements.

Participants used expressions such as “please” and “thank you” appropriately in the online chat discussions. These expressions were not expected to be problematic for the NNS because their usage is similar in English, and familiar to all Canadians. However, it was observed that these two expressions appeared scarcely in the online discussions, especially the word “please”. It might be because there were not a lot of requests amongst participants which would have required the use of this word. The word “merci” for “thank you” appeared mostly in the greetings on arrival, when participants asked each other about their well-being:

(19) Chat-room 5, chat 6

W\*: Bonjour, ça va?  
*Hi, how are you?*

M.J.: Oui **merci**, et toi?  
*Well thank you, and you?*

W\*: Oui, ça va bien **merci**!  
*Yes, I am well thank you!*

Instances of impoliteness were rare; however sometimes a participant expressed impatience towards a discussion taking too long to start or a discussion losing its focus. In this

case, the participant would simply express impatience with a statement, asking the group to begin the discussion or to refocus on the topic, as shown in the following extract.

(20) Chat-room 3, chat 4

S\*: Peut-être nous pouvons parler de Bryan Adams plus tard...de qu'est-ce que nous avons besoin de parler ce soir?  
*Maybe we can talk about Bryan Adams later... what do we have to talk about tonight?*

C\*: Oui, au revoir Bryan Adams, bonjour les voyages  
*Yes, good-bye Bryan Adams, hello traveling*

I: lo, désolée, Sabriane  
*Lol (laughing out loud), sorry, Sabriane*

S\*: haha...plus tard Isabella ;)  
*Haha... later Isabella*

The online exchange allowed participants to take turns to express politeness in a similar way than in a face-to-face conversation. Participants were able to show that they knew how to respect politeness conventions in this particular context. However, a closer look at the choices of words later in this chapter will show some differences between both groups.

### 3. Expressions of Folk-Wisdom

The third category investigated was “expressions of folk-wisdom”. These expressions are fixed formulae that are described in the CEFRL as reinforcing common attitudes and contributing significantly to popular culture. They are found in proverbs, idioms, familiar quotations, and expressions of belief, attitudes and values. Very few of these expressions were found in the discourse of the participants. The few examples found were used by NS: in chat-room 12, “chacun ses goûts” (to each is own taste) and in chat-room 1, “à toi l’honneur” (you do the honours). It seems that the interactive context of the chat exchanges did not foster the use of these expressions.

#### 4. Register Differences

Finally, the last category analyzed was “register differences”. The CEFRL describes this category as the one dealing with differences in level of formality. The framework identifies six levels: frozen, formal, neutral, informal, familiar, and intimate. The language used by the participants in the online chat sessions was characterized by the use of incomplete sentences and the particular use of punctuation. The usual capital letter and the period to mark the beginning and the end of a sentence were not always displayed, and there was an extensive use of exclamation marks and points of ellipsis (...). The content of the message appeared to be more important than the form and a lot of typing errors, spelling and grammar mistakes were left by the participants. A few expressions that would normally be found in an oral conversation like “cool”, or “ouais” for “oui” or “euh” to show hesitation, were also observed in some chat discussions. The following extract shows some of these characteristics.

(21) Chat-room 3, Chat 3

I: alors, quelque'un est un grand explorateur ici?  
*So, someone is a big explorer here?*

J: je commences.....  
*I start...*

C\*: pas moi.... **hee hee**  
*Not me... hee hee*

J: **quelques voyages en banque ouais!**  
*I have some traveling in the bank yes!*

J: lol

S\*: **ha...**j'ai eu des aventures l'été passé  
*Ha... I had some adventures last year*

J: quelqu'un à déjà sorti du Canada ou de l'Amérique??  
*Someone went outside Canada or America?*

J:     *quel genre?*  
        *What kind?*

S\*:    *J'ai voyage seul en Europ pour deux mois.*  
        *I traveled by myself in Europe for two months.*

J:     **ooooo nice!!**

In this extract that represents well the type of language used by the participants in this chat exchange, the structures of the sentences model the ones of a spontaneous oral conversation. There are also a few words added, such as “ha”, “hee hee”, and “ooooo” to mimic the sounds of an oral conversation. Moreover, one of the NS (J) used “**quelques voyages en banque ouais!**” which is an idiomatic expression. Because of these characteristics the language used in the online chat was identified as being at the “informal” level. As shown in the previous extract, the NNS were able to adapt their register to fit the format of the chat. However, as it is presented later in this chapter, it is in the choice of words and expressions that they differed from the NS.

### *5. About the Forum*

The forum was a place for participants to write a personal paragraph on the topic that was discussed in the online chat sessions. It was expected that the language used by the participants in the forum would be more formal than the one in the online chat. In addition of forum promoting the use of complete sentences, participants were aware that their message would be exposed to all the participants of the exchange. Therefore, they might have applied themselves and taken the time to think about the form and content of their message.

Compared to the online chat, the language in the forum was characterized by the use of complete sentences. The punctuation marks resembled the one that would be used on a “paper” piece of writing. It was evident that students put more focus on the form, as there were less

spelling and grammar mistakes. The content was similar to what the instructor would have found if it had been an assignment to hand in. However, in this context, it was easier to see that the NNS were not mastering the language as well as the NS. This observation only emphasized again the nature of chat that allows learners to blend in with NS. It also shows that instructors could use these two mediums for specific learning objectives. Because of the characteristics identified above, the language used by the participants in the forum is identified as being at the “neutral” level.

The two extracts below show some of the differences of language uses between chat and forum. In the first extract, the NNS (M\*) is writing in the forum about multiculturalism in Canada. In the second extract, the same student (M\*) is engaged in an online chat session on a similar topic. The students marked with an asterisk represent the NNS.

(22) Student 11, Forum 3

Le multiculturalisme est partout au Canada. Il est inévitable de ne pas le vivre ici. Toutes les personnes que je connais à Vancouver sont des immigrées ou ses parents sont des immigrants. Au Canada nous avons beaucoup de défilés pour toutes les nationalités. L'autre jour, je suis allée à la célébration de Norooz. C'est la nouvelle année pour les Persans. Je fais aussi la danse de ventre. C'est une danse arabe. Quand je sors pour manger, je mange la nourriture mexicaine, japonaise, et thaïe. Je ne suis pas persane, arabe, mexicaine, japonaise, ou thaïe, mais il y a beaucoup de gens qui vivent à Vancouver qui sont. Puis, j'aime donner mon appui et apprendre tout ce que je peux sur les valeurs et traditions de toutes les cultures au Canada.

*Multiculturalism is everywhere in Canada. It is inevitable not to live it here. Everyone that I know in Vancouver is an immigrant or their parents are immigrants. In Canada we have a lot of parades for all the nationalities. The other day, I went to the celebration of Norooz. It's the New Year for Persians. I also practice belly dancing. It's an Arabic dance. When I go out for dinner, I eat Mexican food, Japanese food and Thai food. I am not Persian, Arabic, Mexican, Japanese nor Thai, but there are a lot of them who live in Vancouver who are. Also, I like to give my support and learn everything about values and traditions of all the cultures in Canada.*

(23) Chat-room 8 – Chat 5

M\*: je pense que "un canadien" n'existe pas... nous sommes tous immigrants.

*I think that a « Canadian » does not exist...we are all immigrants.*

- K: Au primaire, j'ai été dans **un** école **où** il n'y avait **qu'un seule** blanc!  
*At the elementary level, I went to a school where there was only one white person!*
- K: Bien sûr que ça existe  
*Of course, it exists*
- T\*: c'est vrai que le canada est jeune et qu'il y a longtemps que personne vivait ici, mais je crois qu'il y a des canadiens et j'en suis une  
*It's true that Canada is young and a long time ago there was no one living here, but I believe that there are Canadians and that I am one*
- A: à mon école primaire, ce n'était pas très diversifié; on était presque tous italiens  
*At my elementary school, it was not very diverse; we were almost all Italians*
- M\*: je suis **nee** au canada.. mais je me **consideree** plus Argentine que canadienne.  
*I was born in Canada.. but I consider myself more Argentinean than Canadian.*
- K: ça c'est différent...  
*That is different...*
- K: Mais officiellement tu es canadienne  
*But officially you are Canadian*
- M\*: oui. je suis **nee** au canada.  
*Yes, I was born in Canada*
- T\*: pourquoi est ce que **tu te considere** plus Argentine que Canadienne?  
*Why do you consider yourself more Argentinean than Canadian?*
- M\*: parce que mes parents m'ont **trasmises ses** valeurs argentines  
*Because my parents passed on their values to me*
- M\* : chez moi, nous parlons l'espagnol.  
*At home, we speak Spanish.*

These two extracts show that in the forum, sentences are complete and punctuation is the same as what is normally found on a formal piece of writing. There are a few grammatical mistakes but no spelling or typing mistakes. In the online chat, sentences are not complete, punctuation rules are not respected, and there are many linguistic errors left. For example, several words are misspelled such as “où” (where) for “ou” and there are grammatical mistakes,

such as “tu te considere” (you consider yourself) instead of “tu te considères” (grammar and spelling mistakes are in bold in extract 23). There is more attention given to the form in the forum, which is normal because students have more time to write their message than in the chat. These general observations about the type of writing fostered by the different CMC tools confirmed what was previously described by Sotillo (2002).

Besides allowing participants to use a more formal register than in the chat, the forum did not allow for the display of the other sociolinguistic elements described in the CEFRL. Indeed, no linguistic markers of social relation such as greetings were found, no politeness conventions and no expressions of folk-wisdom were found. This indicates that the forum would have not been enough for the NNS to be exposed to the elements of the sociolinguistic competence. Yet, if participants had had to comment on each others’ paragraph, more of these elements probably would have been displayed. Interactions between students would certainly have involved the use of most of these elements. For example, when responding or commenting on the paragraph of one student in particular, we can assume that the participant would have used greetings and would have paid attention to politeness conventions. However, because the forum fosters the use of a more formal register, participants would have used these elements in a more formal manner. Consequently, the use of the forum and the chat in this way, would allowed L2 learners to see how NS use the sociolinguistic elements in the different online contexts and would exposed them to greater sociolinguistic variation.

## *6. Discussion*

The results of this first analysis allowed a better understanding of which sociolinguistic elements instructors can expect to find in a similar online exchange and also confirmed the results of previous research. First, based on previous research (Sotillo, 2002), it was assumed that

the use of the online chat and the forum would allow the NNS to be sensitized to different registers. There were indeed major differences between the discourses displayed in both mediums and the planned activities allowed the NNS to be exposed to these different language forms. Second, it was important to realize that interactions between participants are essential for the practice of sociolinguistic elements. Compared to the online chat, the forum does not automatically involve interaction. For instructors, it means that they could only use an online chat which would expose students to most of the sociolinguistic elements and to an informal register. However, a forum could involve planned activities in which students have to comment and respond to each others' writing. These two combined activities could allow L2 learners to use sociolinguistic elements in both contexts, therefore exposing them to greater sociolinguistic variation. Figure 6 reviews the sociolinguistic elements found in the discourse of the participants.

Figure 6 *Display of Sociolinguistic Elements with CMC Tools*

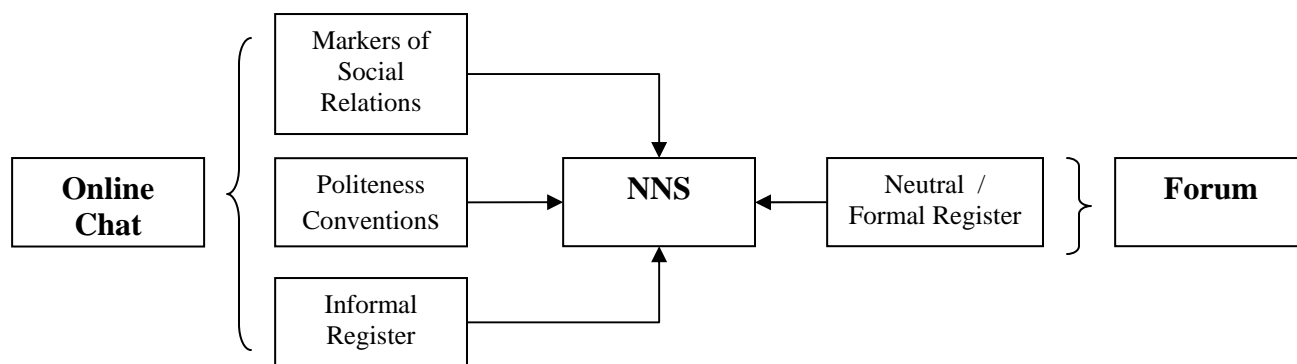

In the online chat sessions, participants used greetings; they chose to use the pronoun “tu” to address each other; they respected the rules for turn-taking; they used expletives; they expressed politeness and they used an informal register. The forum gave them the opportunity to experiment with a more formal register. As it was explained in the rationale of this study, it is the lack of opportunity to experiment with the informal register that has been shown to be

problematic in NNS' sociolinguistic competence. However, research on sociolinguistic development has shown that authentic interactions with NS allow NNS to gradually extend their sociolinguistic competence and thereby develop their capacity to recognize and produce socially appropriate speech in context (Dewaele, 2004). It seems then fair to assume that by providing different context of interactions between NS and NNS that foster different language registers, maximize opportunities for the NNS' development of sociolinguistic competence.

The only category for which almost no elements were displayed is "expressions of folk wisdom". Very few of these expressions were found in the discourse of the participants in the online chat sessions or in the forum. These fixed formulae found in proverbs and familiar quotations are more likely to appear in graffiti, t-shirts slogans, TV catch phrases and posters (Council of Europe, 2001, p.120) than in a day to day conversation. Therefore, it is not surprising that the online chat that promotes an informal register with short sentences did not foster their use. The forum seems to offer a better context for expressions of folk wisdom because it demonstrated a higher level of language complexity but still, these expressions would probably occur sporadically if they did. This suggests that the CMC tools used in this study were not appropriate for the natural display of the elements of this category. Therefore, instructors who want to work on this category with their students should include specific learning activities in the exchange. For example, participants could read or listen to a commercial in which some of these expressions are used and discuss the content of the messages with members of their group.

The results of this first analysis answer partly the first research question. The NNS used different sociolinguistic elements with the NS. In the online chat, they used markers of social relations such as greetings, they expressed politeness, they used a register which was similar to the one of an oral conversation, and the forum allowed them to use and read a more formal

register. This result indicates that these two CMC tools provide support for the use of the sociolinguistic elements in authentic contexts. Moreover, compared to what these students are exposed to in the classroom, this CMC environment gave them access to the way native speakers of their age communicate in these specific contexts. In the next section, differences in the use of sociolinguistic elements between NS and NNS are presented.

### *B. Differences in the Use of Sociolinguistic Elements*

In this part of the analysis, differences in the use of sociolinguistic elements between NS and NNS are described before looking for changes in the following section (C). The first difference concerned the words chosen by participants for greetings on arrival. Participants either used “bonjour”, a formal way for greeting, or “allo” and “salut”, two other informal ways for greeting. The NNS wrote “bonjour” more often than their counterparts who almost never chose this word. NS wrote “salut” and “allo” most of the time. NNS also selected these two words but less often. This seems to indicate that NS recognize “salut” and “allo” as the most appropriate words in this context, and it also indicates a lack of sociolinguistic competence at this level from the NNS. Salutations were usually followed by asking about each other’s well-being. There were a few different expressions found such as “Comment ça va?” a common and neutral way to ask “How are you?”. All participants asked about their partners’ well-being in a similar way. The most popular way to ask by both NS and NNS was “Ça va?” or “Ça va bien”, a shorter version of “Comment ça va?” Participants also often followed their answer by “et toi?” meaning “and you?” which is an appropriate and friendly way to respond.

All participants were more creative in their choice of words on leave-taking. They used various expressions such as “à la prochaine”, “bye”, “bye-bye”, “au revoir”, “salut”, “à tout à l’heure”, “ciao”, “bonne nuit”, “à tantôt”, “à bientôt”. This can indicate that there are multiple

ways to end a conversation in the online chat session, and that perhaps rules for closing are more flexible. Both NS and NNS selected the neutral greeting “à la prochaine” a similar number of times. The greetings of choice for NS was the English word “bye” or “bye-bye” which is quite informal in French, and for NNS, it was “au revoir” which is a more neutral expression for greeting. Again, this indicates that NS recognized “bye-bye” as the most appropriate word in this context and that the NNS used a more formal word.

Differences were also noticed between NS and NNS in their choice of expletives. They did however, use them a similar number of times. Table 4 below shows examples of choice of expletives for both groups.

Table 4 *Choice of Expletives*

NS	NNS
Ouais finalement!! <i>Yes finally!!</i>	Au oui!?!?!? C'est fantastique. <i>Ah yes !?!?!? It's fantastic.</i>
Ooooo nice!! Oh, nice!	Je vois!! c'est bien! <i>I see!! That's good!</i>
Oui, c'est tellement génial!! <i>Yes, it so great!!</i>	Ah oui, c'est intéressant!! <i>Ah yes, that's interesting!!</i>
Aaaa cest cool sa!! <i>Aaaa that's cool that!!</i>	Vraiment, tu es super! <i>Really, you are super!</i>
J'ADORE!! <i>I love it!!</i>	C'est intéressant!! <i>That's interesting!!</i>
Ce n'est pas juste! <i>That's not fair!</i>	Tu as de la chance Elmira! <i>You are lucky Elmira!</i>
Trop génial: super chanceuse! <i>Too great: super lucky!</i>	
Wow!	
Mets-en! <i>Indeed!!</i>	

The expletives used by NS show a mix of English and French, as in “C’est cool ça”, the use of “ouais” instead of “oui”, and the use of specific combinations of words such as “tellement génial” and “super chanceuse”. These expletives belong to an informal register and they seem to represent a “vernacular variety” of speech used by some of the francophone youth of this college. The expletives chosen by the NNS are more formal or neutral, and thus less colloquial. These differences also point to a lack of sociolinguistic competence for the NNS regarding this aspect.

There were no major differences regarding the type and frequency of expressions of politeness between participants. However, it was observed that within each group, participants had their favourite way of expressing politeness towards each other. For example, in one group, politeness was expressed mostly by showing interest in the ideas of others through direct questions, and by expressing their agreement with the others' opinions. In another team, it was common to show affection and admiration. Because no differences between NS and NNS were observed, it seems that NNS were able to recognize the appropriate rules of behaviour related to this aspect, and to respect them.

In relation to negative politeness, participants have equally succeeded in avoiding face-threatening situations. No important differences were noticed in the way they expressed negative politeness, except in their choice of strategies to express hedges. Indeed, NNS used the expression “je pense que” (I think that) many more times than the NS in the online chat sessions. A closer look at the data revealed that NS used as many hedges as their counterparts but that they chose other strategies. For example, they used other introductory phrases such as “Je crois que” (I believe that), tag questions such as “n’est-ce pas?” (isn’t that so?) and approximators of degree such as “généralement” (generally). In the extract below, the participants are discussing the difficulties that an immigrant can face when arriving in Canada. Some of the lines have been removed for the purpose of this analysis.

(24) Chat-room 3, Chat 3

- C\*: **Je pense que:** si un(e) immigré(e) habite au Canada et ne parle pas anglais ou français, il y aura beaucoup de difficulté pout lui/elle.  
*I think that if an immigrant lives in Canada and does not speak English or French, there will be a lot of difficulties for them*
- C\*: Le plus évident est la communication  
*The most evident is communication*

- J: le climat n'a pas été une grosse adaptation pour personne ici? (...)  
*The weather was not a big adaptation for anyone here?*
- S\*: **je pense qu'il** est difficile a faire de nouveaux amis aussi  
*I think that it is difficult to make new friends too*
- J: habituellement les gens se plaignent du climat la langue et la grande diversité culturelle ici comparer a leur pays natif  
*Usually people complain about the weather the language and the big cultural diversity here compare to their native country*
- C\*: **Je pense que** probablement les coutumes. Les coutumes différents causeront la méprise.  
*I think that probably the customs. The different customs will cause misunderstanding*
- J: la socialisation est parfois difficile dans un nouveau pays avec une nouvelle langue...  
*Socialization is sometimes difficult in a new country with the new language*
- E: j'avoue. surtout quand on vient des pays arabes dans les quelles, les femmes se chachent le visage ave les voiles  
*I agree. Especially when you come from an Arabic country in where women hide their face with veils*

The NS (J and E) used different strategies to avoid making absolute statements. J wrote a question instead of an affirmation in his first intervention and also used “habituellement” (habitually), and “parfois” (sometimes); both words are described as approximators of frequency (Salager-Meyer, 2002). E agrees with something that was said by J instead of expressing her own idea. It seems that the NNS might lack these strategies and rely mostly on the phrase “Je pense que”. This difference pointed out to a lack of sociolinguistic competence for the NNS.

Finally, in regards to the choice of registers, both groups were able to adapt their language use to fit both mediums; they used a language which focused less on the form in the online chat than in the forum. As it was described earlier, they used incomplete sentences and adapted to the different uses of punctuation in the online chat. However, a closer look at the discourse revealed that NNS chose words and expressions that were more formal than the ones

chosen by their counterparts. Indeed, besides expletives and greetings, other words and expressions were used by NS that represented a vernacular style as it was shown in extract 21.

Figure 7 reviews the differences between NS and NNS in the use of the sociolinguistic elements identified in the previous section.

Figure 7 *Use of Sociolinguistic Elements by NNS and NS*

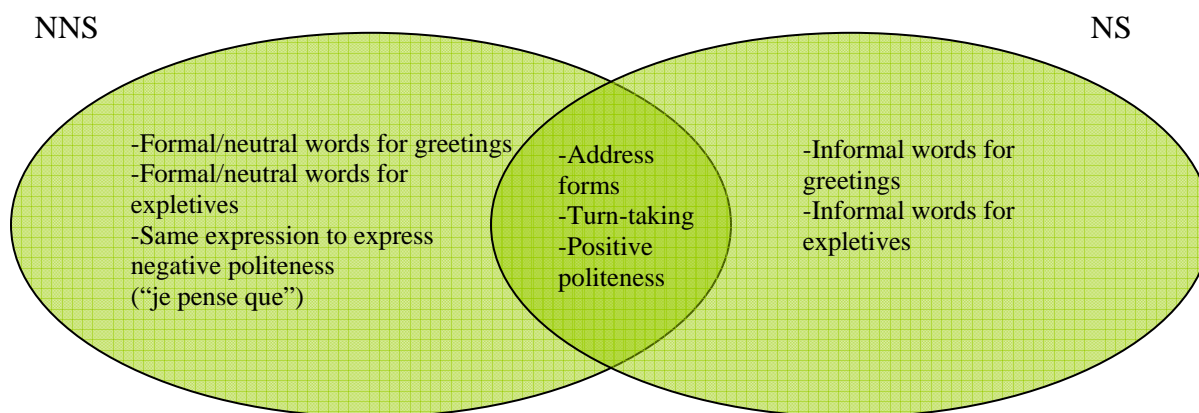

Figure 7 shows that differences were found in the choice of words for greetings, in the expressions of negative politeness and in the choice of words for expletives. In brief, NNS have chosen words which are qualified as more formal for their greetings on arrival and departure and for expletives. This is not surprising because the NNS in this study are not surrounded by French speakers and opportunities to speak French outside the classroom are limited. Therefore, the language they have been mostly exposed to is the one of the classroom, which is usually from a more formal or neutral register.

As the answers to the pre-study questionnaire revealed, some of these students have been to French speaking places before and had the chance to interact with native speakers. However, this exposure was for a limited period of time and not on a regular basis. Considering the important effect of informal contact with the target language in the development of the

sociolinguistic competence (Dewaele & Reagan, 2002; MacFarlane, 2001; Regan, 1995; Rehner & Mougeon, 1999; Sax, 2003) and the fact that this competence is difficult to teach in the classroom (Hinkel, 2001), it seems that the regular classroom activities do not foster the development of this competence. Regular online interactions with NS of the same age group should provide NNS with this opportunity.

In the next section, the results of the research for development of the sociolinguistic competence of NNS are presented. The differences identified above were tracked to see if there were changes in the discourse of NNS.

### *C. Looking for Sociolinguistic Competence Development*

#### *1. Greetings*

Results presented earlier have shown that the NNS in this exchange used “bonjour” in general compared to the NS who used “allo” and “salut”. The following extract shows a possible influence of the NS on the choice of words for greetings for the NNS (S\* and C\*).

(25) Chat-room 3, Chat 3

S\*: Bonjour Joel  
*Hi Joel*

J: allo!!  
*Allo!*

S\*: allo Caroline  
*Allo Caroline*

C\*: Bonjour Sabina... bonjour Joel  
*Hi Sabina... hi Joel*

J: allo Caroline!!  
*Allo Caroline!!*

E: salut, le monde!!!  
*Hi everyone!!!*

C\*: Salut Elmira  
*Hi Elmira*

S\*: .....salut Erica  
*Hi Erica*

E: salut Caroline! Salut Sabina, salut Jo!!! je suis super contente de vous voir!  
*Hi Caroline! Hi Sabina, hi Jo!!! I am super happy to see you!*

In this extract, the NS (J and E) wrote “allo” and “salut”. Both NNS (S\* and C\*) wrote “bonjour” but also “allo” and “salut” in response to the words use by the NS. In further exchanges, they also kept on using “bonjour” most of the time, S\* using “allo” once in chat 5 and C\* using “salut” in chat 6. It seems that in this group, the NS had an influence on the greetings the NNS chose to use. Similar observations were done in one other group composed of five students.

(26) Chat-room 8, Chat 4

A: salut tara!

T\*: salut

T\*: bonjour

M\*: bonjour!!!

A: salut marine!

T\*: salut Kara

K: Salut!

The NS of this group used “salut” and the NNS used “bonjour” most of the times in the other chat sessions. In this extract, Tamara used “salut” and also “bonjour” but still used the later word in the online chat session following this one. This might indicate that the NNS is experimenting with this different way of greetings without totally integrating it in her repertoire.

However, other than a few similar examples, it was hard to find changes in the choice of greetings on arrival for NNS. This suggests that NNS noticed the other greetings but might have needed more time to start using them.

Similar results were found in the choice of words for greetings on departure.

(27) Chat-room 3, Chat 4

J: bref je suis désolé mais je vais devoir vous laissez!  
*So I am sorry but I have to go!*

J: Bye Bye tout le monde!  
*Bye Bye everyone!*

J: xxxxxx  
*(Kisses)*

S\*: Je comprends. Je dois partir aussi  
*I understand. I have to go too.*

S\*: Au revoir  
*See you soon.*

C\*: Au revoir Joel! ... bonne soirée  
*Good-bye Joel!... Have a nice evening*

J: toi aussi 😊  
*You too*

E: Bonne jsoirée. désolée, je me prenais une pomme  
*Have a nice evening. Sorry, I was getting an apple*

C\*: LOL.. mais byee byee à vous!  
*LOL..but bye bye to you!*

S\*: bye  
*Bye*

E: bye bye!  
*Bye bye!*

C\*: okay, au revoir tout le monde!!  
*O.K., see you later everyone!*

In this extract, the NNS (S\* and C\*) naturally chose “au revoir” at first; then in response to the NS who selected “bye bye”, they wrote it as well. Again, it seems that they are very receptive to the expressions used by the NS. Similar observations were made in another group. The NS used “bye-bye” while the NNS used “à la prochaine” (see you next time) and “au revoir” most of the times in the other chat sessions. However, in the last online chat session, changes were observed:

(28) Chat-room 8, Chat 6

K: Bon je dois partir les filles!  
*Well, I have to go girls!*

M\*: ok au revoir kara  
*o.k. good bye Kara*

K: Bye bye!!!

K: C'était la dernière fois qu'on se parlait!  
*It was the last that we were talking to each other!*

A: bye! a vendredi  
*Bye! see you on Friday*

T\*: j'aimerais dire que c'etait du fun parler avec vous  
*I would like to say that it was fun talking to you*

M\*: oui, merci femmes  
*Yes, thank you ladies*

M\*: c'etait un plaisir  
*It was a pleasure*

A: moi aussi je dois partir. j'ai vraiment aimer nos sessions de clavardages...vous etes tres interessantes!  
*I have to go also. I really enjoyed our online chat sessions... You are very interesting!*

T\*: merci! vous aussi  
*Thank you! You as well*

[...]

K: bye bye

A: bye!!! bonne chance dans tout!  
*Bye! Good luck with everything!*

M\*: **bye bye**

[...]

T\*: **salut!**

It is interesting to see M\* using “bye bye” for the first time in the online chat sessions and to see T\* using “salut” also for the first time for greetings on departure. This seems to show that NNS noticed the words used by the NS and that it might have had an influence on the words they chose to use. Again, besides a few similar examples, changes in the choice of words for greetings on departure were difficult to find. However, a certain way of greeting was modeled in one group as shown in the following extract.

(29) Chat-room 3, Chat 2

J: Bref je suis désolé **tout le monde** mais moi je vais aller me coucher!!  
*Well I am sorry everyone but I have to go to bed!!*

J: Bye Bye **tout le monde** xxxxxxxx  
*Bye-bye everyone xxxxxxxx (kisses)*

C\*: bien, au revoir **tout le monde..!**  
*Well, see you later everyone..!*

The NNS (C\*) seemed to model the way the NS (J) wrote by responding to him in the same way. In further online chat sessions, “tout le monde” also appears in the greetings for openings and closings in the turns of all the participants of this group.

## 2. Expletives

The results of the choice of expletives showed that the NNS in this exchange used more formal words than their counterparts. The extract below shows an exchange between a NNS (S\*) and a NS (J) where the NS seem to have an influence on the choice of expletive of the NNS. This extract also shows how synchronous online chat can be a little chaotic as the two participants start to talk about several topics at the same time. Because something particular was observed between these two participants, the two other participants who arrived in the conversation at a later moment were removed.

(30) Chat-room 3, Chat 3

J: sa va ???  
*How are you?*

S\*: finalement! oui, ca va...et vous?  
*Finally! Yes, I am doing well and you?*

J: très bien!!...ouais je sais je suis désolé sa m'a pris du temps avant de pouvoir me libérer  
mais à cause de mes compétitions et tout j'ai un horaire chargé  
*Very well!!...yes I know I am sorry I took me a long time before I could meet you but it is  
because of my competitions and all I have a full schedule*

S\*: Je comprends. Comment s'est passé tes compétitions?  
*I understand. How did your competitions go?*

J: Bien .....je suis maintenant classé dans le top 5 au canada  
*Well..... I am now in the top 5 in canada*

S\*: Au oui!?!?!? C'est fantastique. Dans quel éprouve?  
*Yes!?!?!?!? That's fantastic. In which skill?*

J: vous habitez dans quel coin de la colombie-britannique?  
*You live in which part of british columbia?*

J: 200 mètres  
*200 meters*

S\*: Je pense que Connie habite à Vancouver, et moi, j'habite près de Vancouver  
*I think that Connie lives in Vancouver, and me, I live close to Vancouver*

- J: cool, je vais être à Vancouver cet été pour 1 semaine environ  
*Cool, I will be in Vancouver this summer for almost a week*
- J: vous étudiez en quoi?  
*What are you studying?*
- S\*: cool, est-ce que tu viens ici pour les vacances ou compétition?  
*Cool, are you coming for a visit or for a competition?*
- J: compétition  
*Competition*
- J: championnat canadien  
*Canadian championship*
- S\*: Bonne chance! .....salut Erica  
*Good luck!...Hi Erica*
- J: Merci!  
*Thank you!*

In this extract, S\* used the word « cool » in response to J. She also modeled his answer when asked about her well-being with the shorter version “ça va” by responding in the same way “oui, ça va...”

In general, the expletives used by the NS were not modeled by the NNS. The English words such as “cool”, “wow”, and “nice” were not used by the NNS perhaps because they were making an effort to use French words only. Other expletives including words from the oral informal register such as “ouais” instead of “oui” for “yes” or expressions which may sound funny to English speakers such as “j’adore” which means “I love it” or “génial” used for “great” and “super” were also not selected by NNS. NNS might have chosen consciously not to use these forms because they “belong” to the community of practice that represents this specific group of NS. Dewaele (2004) talks about “in group” membership to describe how members of a group use specific speech patterns to show that they “fit in”. L2 learners using these words could be seen as

out of place and could bring unwanted effects from the interlocutors. This means that a strong trust relationship must take place before NNS have the desire, and most importantly feel welcome, to identify with a group of NS. However, the exchange allowed NNS to notice how these elements were used by NS of their age and might have contributed to their knowledge on stylistic variation.

### 3. Hedges

Results showed that the NNS overused the hedge “je pense que” compared to the NS who chose other strategies such as other introductory phrases or tag questions. The need to resort to that phrase was greater for NNS because they seemed to lack other strategies; it could also indicate a lack of confidence. In the extract below, the participants are discussing multiculturalism in Canada and one of the NNS (C\*) used other strategies in response to the NS.

(31) Chat-room 3, Chat 4

E: j'avoue la diversité, le mélange des deux en toi fait quelque chose de nouveau  
*I agree diversity, the mix of both in you make something new*

C\*: Canada est un pays de multiculturalisme.. si **en général** preuve de tolérance et d'ouverture d'esprit les uns envers les cultures-- **comme Erica a dit**  
*Canada is a country of multiculturalism.. if in general proof of tolerance and openness of the ones towards other cultures—like Erica said*

E: je me suis faite niaiser un peu au début pour mon accent russe que j'avais la première année de mon apprentissage de français  
*People teased me a little at the beginning for my Russian accent that I have in my first year of learning French*

E: mais, je trouve que les gens ici sont formidables et je n'ai jamais perdu de vue qui je suis. Sabina, toi, tu es un méchant cocktail d plusieurs nationalités, n'est-ce pas?  
*But, I find that people here are awesome and I never lost sight of who I am. Sabina, you, you are a powerful mix of several nationalities, are you?*

C\*: et si.. je me rappelle, dans mon école primaire et secondaire.. nous célébrons la fête de chinoise aussi

*And if.. I remember, in my elementary school and high school.. we celebrate the Chinese holiday too*

S\*: Ils sont autres difficultes aussi (comme la discrimination etc.) mais **je pense que** les avantages de multiculturalisme sont plus importants  
*They have other difficulties too (like discrimination etc.) but I think that the advantages of multiculturalism are more important*

C\*: **Donc, vous aimez le multiculturalisme de Canada?**  
*So, you like the multiculturalism in Canada?*

This extract was taken from the last online chat session. “Je pense que” is used only once by S\*. C\* added to her idea the phrase “en general” meaning “in general” and also “comme Erica a dit” meaning “like Erica said” in her first intervention in this extract. Both of these phrases are used as strategies to avoid making absolute statements or to distance herself from the statements. In her last intervention, she asks a question which also shows that she developed another strategy. It is possible that she has developed these strategies by modeling the discourse of the NS which could show the development of her sociolinguistic competence.

A similar observation was made in another group, although the strategies used were less varied. Indeed, the NNS of this group relied most of the time on the expressions “je pense que” while the NS relied on “je crois que” (I believe that) to express hedges. These two expressions are equivalent when used in this sense in French. Interestingly, one of the NNS started using “je crois que” in the third chat and used it again in the last chat twice while before that she had only used “je pense que”. This might show that the NNS developed a new strategy to express hedges and therefore developed one aspect of her sociolinguistic competence.

#### *4. Register*

Results regarding the choice of register have shown that compared to the NS, the NNS had difficulties using lexical and syntactical forms resembling oral speech. They witnessed these

forms but did not incorporate them in their own discourse. The suggestions provided to explain the lack of integration of expletives used by NS in the discourse of NNS could be used here. Indeed, the informal speech style used by NS was characterized by the use of specific words that NNS might not have feel comfortable using. They might have felt that NS displayed a “proprietary attitude towards these words” (Dewaele, 2004, p. 314) and decided not to use them. Besides, if it was their first exposition to these forms in context, they might have needed more time to understand them, to acquire them and to add them to their repertoire.

This closer look at the discourse of the participants allowed for the noticing of few changes in the discourse of NNS regarding the sociolinguistic elements previously identified in this chapter as more problematic for the NNS. In the next section, the previous results are discussed further in order to answer the second sub-question.

#### *D. Discussion on Sociolinguistic Competence*

The discourse analysis of the online chat sessions showed that NNS were able to use most of the sociolinguistic elements effectively and were able to communicate without difficulty with NS. The participants in this study live in different provinces of the same country where the social dimensions of the language they are familiar with are not so different from one group to another. Indeed, at first glance, the NNS seemed to blend with the online chat discussions. It is probable that if these L2 learners would have interacted with students from a foreign country, more differences would have been found in the use of the sociolinguistic elements. For example, the way students expressed admiration towards one’s experience could have sounded inappropriate in another culture. However, the discourse analysis pointed to some differences which were used to observe the development of sociolinguistic competence.

The answer to the first sub-question related to differences and similarities between NS and NNS is therefore positive. Indeed, there were similarities but also differences found in the choice of words for greetings, in the choice of expletives, in the expressions of negative politeness, and in the choice of register for NS and NNS. It was found that the NNS used words for greetings and expletives that were more formal than the ones used by NS, showing a lack of sociolinguistic competence in this context. It was assumed that this would be the case because these L2 learners are learning in a context where the target language is not spoken in the surrounding environment, so they have very little authentic informal communication with NS of their own age group where vernacular styles would be used. Most of their exposure to the target language is in the classroom that provides an exposure that is rather formal with a limited access to other registers. Although students might be exposed to informal language through readings and movies, they probably rarely have the opportunity to use this register in communicative settings with native speakers. Moreover, Mougeon et al. (2002) conducted a research study on material that claim to reflect oral language such as dialogues and interviews and found out that informal variants were almost absent. The intercultural CMC exchange gave NNS an opportunity to be exposed to a register that is not easily available to them. As it was discussed in chapter 2, most of language learners are eager to learn the register that will make them blend in with their interlocutors in a conversation in the target language.

It was assumed that the way NNS used the sociolinguistic elements pointed to a lack of sociolinguistic competence. A closer look at the use of these elements in the discourse of NNS showed a few examples of changes over time. In these few examples, it seemed that NS did have an influence on the NNS. A few examples of changes were found in greetings on arrival and departure, in choice of expletives, and in the use of strategies to express hedges. In the case of

the use of hedges, examples were given in which NNS have used a different strategy besides “je pense que” to express hedges in their discourse. “Je pense que” has the same function as “I think that” in English and it was without doubt the easiest way for NNS to express hedges. Compare to the NNS, NS used various strategies, such as adding “parfois” (sometimes) or “I believe” (je crois). The changes observed in the discourse of the NNS seemed to have occurred in reaction to the language behaviour of the NS. These results are similar to the ones by Lee (2004) who found that L2 learners interacting with NS recognized different registers, discourse patterns and style and imitated these new language forms by integrating some of them in their own discourse.

Are these few changes enough to answer the second sub-research question? Was there evidence of sociolinguistic competence development for the NNS involved in the intercultural CMC exchange? No, however, the changes observed in the discourse of the NNS indicated that some of the NNS were sensitive to the way NS used the sociolinguistic elements. As pointed out by Rehner (2002), researchers looking at measuring sociolinguistic development of L2 are faced with speakers with a repertoire in a state of flux. This state of flux is influenced by several independent variables such as social characteristics, situational variables, the influence of the first language(s), the degree of exposure to the L2, and the type of input received through instructors and pedagogical material. Therefore, the few changes observed in the discourse of the NNS are difficult to interpret. Indeed, some participants might have been less ready than others to acquire knowledge about sociolinguistic rules. Dewaele (2004) suggests that sociolinguistic knowledge has to become “proceduralised” before users can make automatic decisions about appropriateness (p. 315). It means that the L2 learners in this research study might have needed more time before starting to use new linguistic forms. Added to this is the suggestion that NNS

might have not been ready to identify with the in-group that represented the NS, as it was previously discussed.

Finally, the answer to the main research question is definitely positive. Without a doubt, this CMC exchange with NS provided an environment which was conducive to the development of NNS' sociolinguistic competence. By chatting online with NS of the target language, NNS were exposed to a register that is not available to them in the classroom. Online chat allowed NNS to see how NS used the sociolinguistic elements in their discourse, through their choice of words for greetings, in the way they express positive and negative politeness and in their choices of expletives. The forum was used to display a more formal register, to which NNS were able to adapt. As O'Dowd (2003) mentioned in his work on cultural competence development with CMC, in a short period of time such as the length of a semester, we can expect that students will at least develop sensitivity to the subject that is to be learned.

Seen in the perspective of sociocultural theory, the exchange provided the conditions necessary for second language acquisition as L2 learners engaged in meaningful social interactions with more capable social members. Learners were active agents as they were pushed by their motivation to socialize with others to produce coherent discourse that went beyond linguistic and grammatical accuracy (Lee, 2004). The authentic audience pushed L2 learners to refine their writing and to pay attention to meaning and form. Within sociocultural theory, the first step to developing language is through interaction with others, and then through integration into the individual's mental structure.

In conclusion, CMC exchange with NS seems to be a valuable substitute to face to-face interactions to develop the sociolinguistic competence for those who do not have the opportunity to immerse themselves in the target language environment. In this study, the use of a forum and

of an online chat to communicate with NS allowed L2 learners to experiment with two language registers, one of them being difficult to access in their learning environment. With these exchanges, they noticed the way NS used the sociolinguistic elements. Some NNS seemed to have modeled these language behaviours as some changes were observed in their discourse. This exchange also allowed L2 learners to engage in meaningful discussions on culture without being limited by their level of proficiency. This important observation is explored further in the next chapter where the characteristics of this language practice are analyzed.

## V. Results: Characteristics of Language Practice

This chapter presents the results related to the characteristics of the language practice fostered by the intercultural CMC exchange. This exchange was expected to have an effect on the overall language competence of the L2 learners because of the additional practice it provided. Indeed, this activity was an opportunity for these NNS to discuss further with NS the topics brought in the classroom by the instructor and to write in a group forum about the discussed topic. It was also expected that by discussing cultural topics, the NNS would gain insights into the culture of their francophone partners. Indeed, NS-NNS chat conversations have been described as providing “culture learning in action” (Toyoda & Harrison, 2002; Levy, 2007) and as bringing language and culture together to the learners (Kern, Ware & Warschauer, 2004).

This chapter reports the results that address the second research question related to the characteristics of this specific language practice and how it can support the development of the sociolinguistic competence.

### Question Two

What characteristics of the intercultural CMC exchange as a language practice supported the development of the sociolinguistic competence?

The objective of this second research question was to understand better how the presence of the native speakers in the interaction, and the fact that the exchange was online, supported the development of the sociolinguistic competence. In order to answer the second research question, a qualitative analysis of the answers of the post-study questionnaires and of the interviews was conducted. From this analysis, three major aspects emerge; answers related to: 1) language learning; 2) cultural contact; and 3) CMC tools. The results on these three aspects are presented

below separately and are followed by a discussion in order to answer the second research question.

### *A. Language Learning*

#### *1. Language Aspect in Post-Study Questionnaires and Interviews*

In the post-study questionnaires, NNS were asked to comment on what they liked the most about the online exchange with NS. About a third of the NNS' answers (37%) contained a part related to a language aspect. These answers were regrouped into two categories: 1) additional practice and 2) increase of confidence. Answers chosen to illustrate each category are presented in Table 5.

Table 5 *Answers Related to Language Learning in Post-Study Questionnaires*

Liked about the exchange	Answers
Additional practice	<p>“It was a good chance for practicing the expression and comprehension.”</p> <p>“It gave me an opportunity to use French outside the classroom.”</p>
Increase confidence	<p>“It increased my confidence to chat in French.”</p> <p>“The chance to interact with new people in a second language which help improve my confidence in French.”</p>

Table 5 shows that NNS recognized that the online exchange gave them the opportunity to use their L2 outside the classroom. This is not surprising because for most of NNS, the only time they can use French is in the classroom. NNS also described an increase of confidence in

the use of their L2. Again, because these language learners do not have the opportunity to practice with speakers of the target language, they may have had some doubt about their ability to engage in natural conversations with NS. The online exchange helped them realize that they were able to do so, and this had an effect on their confidence level.

In the interviews, students were asked questions which were directly related to the language learning aspect. When students were asked if they learned new vocabulary and expressions, the majority of the answers were positive (84%). The descriptions they provided on how the exchange helped them in their learning were divided into two general categories. Table 6 shows a few direct quotes to illustrate these categories.

Table 6 *Answers Related to the Learning of New Vocabulary and Expressions in Post-Study Interviews*

Positive	Answers
NS providing support	<p>“Some, new expressions, definitely because we are not really taught general expressions that people use but talking to students in Montreal, they used them so we picked them up a bit.”</p> <p>“Yes, there were lots of words that I was just like what does that mean? And they were very good at explaining it.”</p>
Practice	<p>“I had the chance to use French outside the class. So if I learned something in class that day, I would go out and type, try to use subjunctive, try to use future simple, so it helped me with school big time.”</p> <p>“I tried to use new vocabulary in the chat so it was I think a good chance.”</p>

Table 6 shows that NNS recognized the NS as helpful in the learning of new vocabulary and expressions. They explained that this support was either provided directly, when NS told them how to say things properly and explained the meaning of specific expressions, or indirectly, when they learned by seeing expressions and vocabulary used in context. NNS also recognized the additional practice provided by the online interaction as helpful in their learning of new vocabulary and expressions. Most students agreed that the online exchange had somehow benefited their language learning.

When students were asked if the exchange increased their confidence to interact with Francophones in the future, the majority of the answers were positive: 58% of students said “yes”, 32% of students said a “little” or “I think so”, and only 10% of students said “no”. Table 7 shows examples of answers provided by NNS.

Table 7 *Answers Related to Confidence in Interviews*

Positive	Answers
Definitively	“Yes, definitely. Now I see that if I make mistakes, and I did lots of mistakes, they would do their best to try to understand what I was trying to say and they would answer without making me feel bad.”
Maybe	“Yes, I think so. At first, you are wondering, am I saying the right thing? And after, you realized it is not such a big deal about mistakes either so...”  “I think so. I think the more that you expose to force yourself to get you out of your comfort zone, the more that you become comfortable.”
A little	“Probably a little bit because like I said you had to think in French instead of translating and I mean I still had problems with some words but you still get that rhythm of having to think in French.”

These answers show that the online exchange with NS served as a confidence builder. NNS realized that they were able to participate in meaningful discussions with Francophones even if they were making mistakes. For these language learners, realizing that they can use their L2 in an authentic context was a real world validation of what they learned in the classroom. This is rather important for language learners who often need encouragement in their learning journey.

The NNS were asked if they noticed a difference in the language used in the chat and in the forum, and also if they were able to adapt their language to both mediums. The majority of the students (89%) said that they observed a difference in the language used in both mediums. Table 8 shows examples of words chosen by students to describe the chat and the forum.

Table 8 *Description of Online Chat and Forum in the Interviews*

Online tools	Descriptions by NNS
Online Chat	<p>“Resemble oral speech with not so much attention given to grammar”</p> <p>“Shorter sentences”</p> <p>“More colloquial expressions”</p> <p>“Use of slang”</p> <p>“Informal, fun, more relax, comfortable and casual”</p>
Forum	<p>“More structured”</p> <p>“Well written”</p> <p>“Formal”</p> <p>“Clear, concise”</p> <p>“More focused on sounding proper with right words and correct grammar”</p>

Table 8 shows that students differentiated two types of language use in the mediums. The words used to describe online chat show that students recognized the use of a register that is more informal and that resembles oral speech. This means that they were conscious of the use of

a different register and that they noticed new items and rules, which is a good start for the development of stylistic variation. They also used the words “more relaxed”, “comfortable” and “fun” used in their description of the online chat show that they enjoyed using their L2 in this environment.

NNS reported that their francophone partners provided them support in the development of new vocabulary and expressions. In the goal of understanding better how this support was provided, instances of “negotiation of meaning” were investigated in the exchange and the results are presented in the next section.

## *2. Looking for More Clues: A Search for Negotiation of Meaning*

Previous research has shown that written CMC such as online chat fosters “negotiation of meaning” (Lamy & Goodfellow, 1999; Pellettieri, 2000; Toyoda & Harrison, 2002), a process which has been identified as facilitating language acquisition in the field of L2 acquisition (Long, 1983; Pica, 1994; Varonis & Gass, 1985). “Negotiation of meaning” happens when there is a break in the flow of the communication between interlocutors that requires repetitions, comprehension checks, clarification requests or expansions (Pica, 1994). In this study, it was expected that many instances of negotiation of meaning would be found in the online chat sessions. Indeed, the L2 learners were of intermediate level and were expected to be facing communication breakdowns that would require negotiation of meaning. Surprisingly, these instances appeared scarcely in the overall transcripts of each group. Instances of negotiation of meaning were collected and categorized by type of negotiation and by type of participant (NNS and NS). Self-repetitions over spelling mistakes (i.e. repeating a word with the correct spelling) was the type with the most instances (39%), followed by self-repetitions over grammar mistakes (22%) and by request for the meaning of a specific word or expression (14%). Self-repetitions

over spelling mistakes was the only category occurring more often in the NS discourse. NS also seemed to only do self-repetitions on spelling when they realized that the word they had written did not make any sense. They barely did any self-repetitions on grammar mistakes that they were also making. A lot of the participants used the asterisk (\*) to point out that they were correcting something they had written previously. The following excerpt shows self-repetition over a spelling mistake.

(32) Chat-room 3, Chat 3

J: est-ce que quelqu'un connait le sujet du **jou**?  
*Does anyone knows the topic of the day?*

I: salut!!!! alors, tous les immigrants ici présents, dites moi qu'est-ce que vous avezz  
trouvez dur au canada?  
*Hi!!!! so, all the immigrant here, tell me what you found hard in Canada?*

J: **jour**\*  
*Day (correcting the spelling mistake)*

The very low score of requests for clarification of an idea, of an expression or of a word by NNS is interesting. It suggests that the support perceived by NNS was provided mostly in an indirect way by NS. The small size of the groups and the fact that participants were involved in meaningful interactions seem to have provided an effective vehicle for communication flow, for the construction of a collective meaning and for the prevention of communication breakdowns. The following excerpt is an example of the conversation building upon everyone's contribution to the discussion.

(33) Chat-room 3, Chat 2

S\*: J'ai fait un voyage avec ma mère et sur cette voyage nous avons devenu plus  
proche. Et quan j'ai voyagé seul, j'ai appris beacoup de chose environ mois (??) et j'ai  
devenu plus indépendant  
*I traveled with my mom and on that trip we became closer. And when I traveled alone,  
I learned a lot about myself (??) (to indicate that she is not sure that she is saying it  
right) and I became more independent*

- J: tu devient plus mature et débrouillard quand tu voyage seul sa c'est très vrai!  
*You become more mature and resourceful when you travel alone that is true!*
- C\*: Je ne voyage jamais seul... mais je vexu!  
*I never traveled alone... but I want to!*
- C\*: Je pense que il y a beaucoup de leçons que on ne trouve pas dans un livre mais on les apprend dans un voyage.  
*I think that there are lots of lessons that we don't find in a book but we learn them in a voyage.*
- J: c'est très diffrent que de voyager en groupe  
*It is very different than traveling in a group*
- I: pourquoi?  
*Why?*
- S\*: Oui, la débrouillardise et très important.  
*Yes, resourcefulness is very important*
- S\* : Parce qu'il n'y a personne à faire attention de toi  
*Because there is no one to pay attention to you*
- S\*: je veut dire....soigner  
*I mean... to take care*

In this extract, the non-native speaker (S\*) seemed to be lacking words to express her idea in details. The native speaker (J) introduces a new vocabulary word, the adjective “débrouillard” (resourceful) in the conversation to expand on her idea that she used in the form of a noun “la débrouillardise” (resourcefulness) in a further sentence. It is difficult to know if the non-native speaker knew this word or not, but the discussion helped her to add precision to her own idea.

In this extract, there are lots of spelling and grammar mistakes made by the NNS such as: “cette voyage” should be written “**ce** voyage”; “nous avons devenu plus proche” should be written “nous **sommes** devenus plus proches”. There are also spelling and grammar mistakes made by NS: “tu devient” for “tu deviens” and “très diffrent” for “très différent”. There are also

very low instances of negative feedback, meaning that the interlocutors rarely correct each other's mistakes. With the fast pace of interactions in chat, the focus is on the meaning of the message rather than on the form. This explains why both NS and NNS have grammatical and spelling mistakes in their message.

It is probable that in total, the NS made fewer mistakes than the NNS because of their better knowledge of the language. But the fact that they were also making mistakes seem to have be beneficial for NNS who felt more comfortable expressing themselves in a place where everything did not have to be perfect. This aspect of chat could also not appeal to instructors who are afraid that the lack of attention paid to the form of the message could give their students bad habits regarding the respect of grammatical rules and correct spelling. However, some research studies have discussed the fact that this aspect has benefits for language learners such as pushing them to try out new forms of language to meet communicative demands (Beauvois, 1998; Gass & Selinker, 2001). In the case of sociolinguistic competence development, it seems to be beneficial for the students to find themselves in a communicative setting where they do not have to worry about making mistakes and where they feel at ease trying new forms to communicate efficiently.

There were also few requests for clarifications related to the use of sociolinguistic elements. In the case of choice of words for greetings, the NNS knew all the words used by the NS and their meaning. The NS just showed them that these choices were more appropriate for the context of communication. The same observations can be made for the expression of negative politeness such as hedges. However, the words used for expletives and other informal words or expressions might have been unknown by the NNS. The extract below shows a few expletives used by the NS (J and I) and how the NNS (S\* and C\*) reacted to them.

(34) Chat-room 3, Chat 3

S\*: J'ai voyagé seul en Europe pour deux mois.  
*I traveled by myself in Europe for two months.*

J: **ooooo nice!!**

J: quel coin de l'Europe  
*Which part of Europe?*

C\*: Vraiment Sabina? mon ami fait ça maintenant  
*Really Sabina? My friend is doing that at the moment.*

S\*: J'avais voyagé en France, Angleterre, Irlande et en Pologne.  
*I traveled in France, England, Ireland et in Poland.*

S\*: C'était une expérience incroyable. Je le recommande à vous  
*It was a wonderful experience. I recommend it.*

J: si j'avais plus de temps je ferais ça aussi....mais je voyage déjà en Europe grâce à mes compétitions...mais ça doit être très différent seul !!!  
*If I had more time I would do that as well...but I already travel in Europe because of my competitions...but I must be very different by myself!!!*

I\*: **Wow**, une vraie exploratrice. J'étais en Russie, en Suisse et en Turquie  
*Wow, a real explorer. I went to Russia, in Switzerland and in Turkey.*

I\*: **mets-en**, je suis d'accord avec Joel  
*Indeed, I agree with Joel.*

I\*: je n'ai jamais voyagé toute seule  
*I never traveled by myself.*

C: Moi, je n'ai pas visité beaucoup de pays parce que, être dans une famille de cinq personnes, c'était très cher pour nous.  
*Me, I never visited a lot of countries because, to be in a family of five, it was very expensive for us.*

I\*: j'aurais peur d'avoir un **méchant** accident sur l'avion. ce ne serait pas amusant pour ma famille  
*I would be scared to have a terrible accident on the plane. It would not be amusing for my family.*

In this extract, the NS (J) used “ooooo nice!!” and the other NS (I) used the expletives “wow” and “mets-en” (indeed), and the word “méchant” an informal word that can be used to

say “terrible” or “amazing” depending on the context. All these examples were easy to understand for the NNS, especially the English words. However, it is probable that the NNS did not know the expression “mets-en”. Yet, they did not need to ask for its meaning because the context probably helped them guess what it meant. It is also possible that the NNS ignored that expression because the understanding of its meaning was not necessary to understand the rest of the sentence. Similar results were found in the other groups regarding expletives and the use of forms from the informal register. The following extract shows another similar example.

(35) Chat-room 3 – Chat 4

J: sa se compare a la fete du canada dans toutes les autre province, ici au lieu de feter la fete du canada cest la st-jean-baptiste qu'on fete  
*It is similar to Canada Day in all the other provinces, here instead of celebrating Canada Day it is Saint-Jean Baptist Day that we celebrate.*

I: c'est une vraie occasion de se laisser aller et **niaiser en gang d'amis** et célébrer durant les journées d'affilée  
*It is a real occasion to let go and to fool around with friends and to celebrate during a few days.*

S\*: On ne celebre pas la st-jean-baptiste ici...je crois  
*We don't celebrate Saint-Jean Baptiste here...I think.*

The expression “niaiser en gang d’amis” (in bold) is a colloquial expression meaning to fool around with friends. In this extract, the NNS do not question its meaning because they perhaps understood the general sense of it or because they did not need to understand each word to follow the on-going discussion. In general, the expressions or way of saying were added to the on-going discussion and seemed to not have affected comprehension for the NNS. In the extract below, both NS (K and A) used ways of saying which belong to the informal register (in bold).

(36) Chat-room 8 – Chat 4

M\*: Ma soeur m'a telephone pour me dire que nous avons des billets pour aller au Thailande en avril!!!  
*My sister phoned me to tell me that we have tickets to go to Thailand in April!!!*

M\*: c'est un cadeau pour ma fete!!!  
*It is a gift for my birthday!!!*

T\*: J'ai la chere pale et je brule vite. J'ai besoins d'un endroit ou je peux passer du temps sous les arbres dans les ombres.  
*My skin is pale and burns easily. I need a place where I can spend time under trees in the shade.*

K: Chanceuse! J'ai vu des phots de là-bas et ça m'a l'**air génial!**  
*Lucky! I have seen pictures from there and it looks awesome!*

A: je suis **tellement jalouse** de toi maureen!  
*I am so jealous of you Maureen!*

A: quand est ta fete?  
*When is your birthday?*

T\*: ca sera **tellement du fun!** j'aimerais passer du temps en Thailand. As tu vu le film "A broke down palace"?  
*It is going to be so fun! I would like to spend time in Thailand. Have you seen the movie "A broke down palace"?*

These forms didn't affect the flow of the discussion, and moreover, the NNS (T\*) responded with a similar form. However, the colloquial way should have been “tellement **le** fun” instead of “tellement **du** fun”. In this case, T\* is using this expression in the right context without mastering it as a whole. Perhaps, the next acquisition step will be to use it correctly.

In regards to the sociolinguistic competence, the results of this section suggest a few lines of thinking. First, NNS were not intimidated by the online exchange, they found it useful as a language practice and it helped them to increase their confidence in using their L2. In this context, NNS might feel comfortable in trying out new forms in a register they are not familiar with such as the informal register. Second, NNS noticed that the NS used a different language style in the online chat. The fact that they did not question the meaning of new linguistic forms suggest that the support provided by the on-going discussion allowed NNS to understand the essence of the message transmitted and to respond to it while being exposed to new forms of

language in context. As seen in the analysis above, most of the sociolinguistic elements used by NS were easily understandable and what NNS learned was that they were appropriate to the context. NNS were not bothered by “unknown” linguistic forms, as these forms did not seem to get in the way of the general meaning of the on-going discussion. These conditions also appear to be beneficial for the development of sociolinguistic competence. Indeed, L2 learners witness sociolinguistic elements used in an authentic social context and participate in meaningful discussions without being limited by their level of proficiency.

In the next section, results drawn from the post-study questionnaires and from the interviews on the cultural aspect are presented. Afterward, excerpts of the chat exchange are presented to further the understanding of this aspect.

### *B. Cultural Contact*

The second theme that emerged from the post-study questionnaires and interviews concerned the kind of cultural contact the NNS experienced with their partners in the intercultural CMC exchange.

#### *1. Cultural Contact in Post-Study Questionnaires and Interviews*

In the post-study questionnaires, many NNS' answers on what they liked the most about the online exchange contained a part related to a cultural aspect (63%). In the interviews, NNS brought up a cultural aspect after two general questions: 1) Did you like using the online chat to interact with Francophones? 2) Do you have other comments to add about what the exchange brought to your experience as L2 learners? Answers from the questionnaire and the interviews were divided into two categories. Examples for each of these categories are presented Table 9.

Table 9 *Answers Related to Cultural Contact in Post-Study Questionnaires and Interviews*

Interactions	Learning
“It gave me an opportunity to speak with people in Quebec, something I would never have done otherwise”	“Learning about different opinions”.
“It was fun to interact with French speakers”.	“I learned some things about other cultures”.
“The chance to interact with new people in a L2”.	“I actually learn a lot from them both
“It was nice in the sense that you could communicate with people that you usually don’t communicate with.	from a culture and knowledge perspective”.
Also, you got to tell other people about yourself”.	“I was able to learn a lot about my
“I really liked it because otherwise I wouldn’t have a chance to enter in contact with anybody from Quebec, I	partner’s culture and a bit about the culture of Montreal.”
don’t know anybody there.”	“I thought it was good to understand
“I liked it because you sort of got to know different people, different part of the world, different cultural	their culture, understanding where they came from because they spoke
heritages. We had a Greek, a Polish and a Korean. It was really cool to hear different experiences when we were	about things differently so I thought that was really good.”
talking about travel, where everyone wanted to go was so different because of that. Yes, I would do it again.”	

This table shows that for many NNS, what they enjoyed the most was the interaction with their partners. They appreciated the opportunity to meet new people with whom they had to exchange in French. Second, they enjoyed learning about culture, about different opinions and

views on the topics. These answers seem to indicate that participants were able to make meaningful connections with each other in this environment. The online exchange provided an environment in which they were able to learn about each other's respective culture, to express and to hear about their opinions. Moreover, the online exchange allowed the participants in a group to discover each other's "personal story" and brought forward a multicultural dimension. In the next section, extracts of the exchange are presented in the objective of understanding further this particular aspect.

## 2. Culture as Individual

Participants in this exchange were from schools composed of students with various cultural backgrounds. In several of the discussions, students talked about their personal experiences and rarely tried to make general statements about the cultural group they were part of. Students were inclined to share aspects of their personal lives to contribute to the discussion. This extract of a chat exchange illustrates this aspect.

(37) Chat-room 15, Chat 4

E: Aussi, je trouve que pour nos parents, il est plus difficile de s'intégrer à la vie canadienne.

*Also, I find that for our parents, it is more difficult to integrate in Canadian life.*

N: Bien sûr, ils viennent d'un autre pays avec de la culture très différente que celui qu'on a ici au Québec.

*Of course, they come from another country with a very different culture than the one here in Quebec*

Sa\*: je crois que si quelqu'un déménage et ne sait pas comment parler la langue, il sera très seul

*I believe that if someone moves and doesn't know how to speak the language, he will be very lonely.*

S\*: Oui, mes grand-parents ont habité en Canada pour 46 ans, mais ils ont des difficultés encore.

*Yes, my grandparents have been living here for 46 years, but they still have difficulties.*

S\*: Ils sont venus de Grec.  
*They came from Greece.*

Sa\*: c'est surtout difficile quand ils ont vécu le plupart de leur vie ailleurs que le Canada  
*It is even more difficult when they have lived most of their lives somewhere other than Canada.*

Sa\*: et quand ils sont vieille il ne peut plus apprendre les nouveaux choses  
*And when they are old, they can't learn new things.*

E: Mais mes parents sont tres ouverts au changements et ils se sont bien debrouilles jusqu'a date.  
*But my parents are very open to change and they have been very resourceful until now.*

E: A vraie dire, je n'ai pas eu un choc culturel, j'ai ete bien traite par la societe canadienne.  
*To tell you the truth, I did not have any cultural shock, I was well treated by Canadian society.*

This extract shows that students felt comfortable and safe in sharing personal aspects of their lives. The online chat seemed to have fostered the disclosure of each other's individual cultural background rather than the presentation of general aspects of each other's respective cultural group. This aspect was also discussed by some students in their last chat, when they were asked if they learned about Canadian culture by doing the exchange.

(38) Chat-room 6, Chat 4

F: Dans un sens oui. Cependant, je ne crois pas que la culture canadienne a vraiment ete exploite dans nos periodes de chat  
*In a sense yes. Nonetheless, I don't believe that Canadian culture has been really exploited in our chat sessions.*

F: On a parle de nos voyages....de nos traditions  
*We talked about our trips... about our traditions.*

- M\*: hmmm pour moi, je crois que j'ai appris la multi-culture parce que vous trois etes immigrés. ^^Mais c'est tres interessant de échanger les choses, les valeurs, et les voyages.  
*For me, I think that I learned about multiculturalism because you are three immigrants. But it is really interesting to exchange on things, values and trips.*
- F: Je ne suis pas une immigrée! Je suis née ici!  
*I am not an immigrant! I was born here!*
- F: Mais je vois ce que tu veux dire!  
*But I understand what you are saying!*
- M\*: Je suis d'accord. Quest-ce que la culture Canadienne? Je crois qu'il y a beaucoup de cultures différentes.  
*I agree. What is Canadian culture? I believe that there are lots of different cultures.*
- F: Je crois qu'il y a certaines valeurs qui sont a la base de presque toutes les cultures (ex: le respect...). Donc, je ne pense pas que nous avons vraiment examiné la culture spécifique du Canada  
*I believe that there is some values which are at the base of almost all cultures (eg. respect...). So, I don't think that we have really examined the specific culture of Canada.*
- M\*: Oh, désolée. Je pense que tu as encore les valeurs traditionnels qui sont importants pour toi.  
*Oh, sorry. I thought that you still have the traditional values that are important for you.*
- F: \*dans  
\*in
- M\*: Oui c'est vrai. On échange nos opinions et les traditions, pas la culture Canadienne en général.  
*Yes, it's true. We exchanged our opinions and our traditions, not the Canadian culture in general.*
- F: Par exemple, nous avons jamais parler des nations autochtones (aboriginaux) canadiennes ou de nos sports (hockey, curling, etc.) ...  
*For example, we never talked about the canadian autochtones (aboriginals) or about our sports (hockey, curling, etc.) ...*

Many of the students discussing on this topic agreed that the exchange allowed them to learn about each other's cultural background and not so much about Canadian culture. Others

however, included the multiculturalism in their definition of Canadian culture, as shown in the following extract:

(39) Chat-room 5, Chat 4

W\*: Moi, je crois que oui. J'ai appris que la culture canadienne est tellement divers, et aussi, il y a beaucoup de gens qui vient d'ailleurs.  
*I believe so. I learned that Canadian culture is so diverse and also, that there are a lot of people coming from everywhere.*

M.J.: Oui! C'est la première fois que je participe à une échange et ça m'a vraiment plu. J'ai également appris à connaître les avis des autres sur la culture canadienne et etc. Par contre, en gros, cet échange m'a vraiment permis d'apprécier la culture canadienne.  
*Yes! It is the first time that I participated in an exchange and I really appreciated it. I also learned to about others' opinions on Canadian culture and etc. Also, in brief, this exchange really allowed me to appreciate Canadian culture.*

These last two extracts show that NNS had different opinions on what the exchange brought to their cultural knowledge. For some of them, learning about their partners' personal cultural background was not learning about Canadian culture and for others, it was. Their difficulty in defining Canadian culture also appeared into parts of their discussion as shown in the extract below.

(40) Chat-room 8, Chat 5

A: donc, que'est ce que vous pensez du fait d'avoir 2 cultures?  
*So, what do you think about the fact of having two cultures?*

S: Moi je trouve ça super, car j'ai la chance de découvrir 2 cultures différentes et ce la m'a aussi permis de découvrir la Thaïlande à un jeune âge.  
*I find it awesome, because I have the chance of discovering two cultures and this also allowed me to discover Thailand at a young age.*

M\*: je pense que la culture canadienne n'existe pas, donc, je pense j'ai un culture  
*I think that Canadian culture doesn't exist, so I think I have one culture only*

A: pourquoi dit tu que la culture canadienne n'existe pas?  
*Why do you say that that Canadian culture doesn't exist?*

A: ???

M\*: peut-etre elle est difficile de decrit. La cuisine? la culture? Les coutumes?  
*Maybe it is difficult to describe. The cooking? The culture? The traditions?*

A: je pense que la culture canadienne est un sorte de melange de toutes les cultures  
*I think that Canadian culture is a kind of mix of all cultures.*

M\*: oui, vous avez raison  
*Yes, you are right.*

In this extract, the non-native speaker (M\*), started the discussion with a bold statement which provoked an immediate reaction from another student (A). The discussion went on for a long time but by the end of this extract, both students concluded that Canadian culture is “a kind of mix of all cultures”. The results related to the cultural contact afforded by the exchange show that students enjoyed the opportunity to interact with students from another province and to hear about their opinions and views. A closer look at the interactions showed that participants revealed aspects of their culture that were both personal and subjective and that they were inclined to share aspects of their personal lives to contribute to the discussion. Moreover, the interactions showed that participants were involved in meaningful discussions and were able to do so even if they were in a virtual world and even if they were restrained by language barriers.

In regards to the sociolinguistic competence, the results suggest that this learning environment supported the development of social relationships. As relationships grow stronger, L2 learners could be pushed to adopt the vernacular style used the NS to identify with the “in group” membership represented by the NS. As it was discussed earlier, this adherence also has to be welcomed by the NS who may have a proprietary attitude towards the use of specific words and specific language style (Dewaele, 2004). Social bonds can also motivate learners to attempt more “native-like” performance (MacFarlane, 2001). But what can be said about the characteristics of this CMC environment compared to face-to-face interactions? Results related to this aspect are presented in the next section.

### C. CMC Aspect

#### 1. CMC Aspect in Interviews

In the interviews, students were asked to compare the use of online chat with a face-to-face interaction. Answers to this question were divided in two categories and examples for each of these categories are presented in Table 10.

Table 10 *Comparing Online Chat to Face-to-Face Interaction*

More time	More freedom
<p>“Yes, well a little bit easier cause when I was 16, I went to Quebec for an exchange and it was really hard cause they spoke so fast and then when you are writing you can think about it”.</p> <p>“I thought it was much more easier because if they asked you a question and you didn’t really understand the question, you had sometime to reflect on what they were asking and if it was face-to-face, you would have to answer right away”.</p> <p>“Yes, you do have more time to reflect on your answer and come up with more well thought out answers versus just trying to say something because your face-to-face”.</p> <p>“Probably easier than face-to-face, just because there was a time lapse between when you wrote something and</p>	<p>“Yes, again the less pressure, because I didn’t really know who I was really talking to, I wasn’t really worrying about...”</p> <p>“I think that you feel a bit more free to put down your own opinion without being judged”.</p> <p>“It’s more comfortable because you take your time to say what you want to say instead of meeting with somebody and feeling weird around them cause you don’t really know them at first”.</p> <p>“A face-to-face conversation might</p>

<p>when it was actually put onto the computer, you could actually kind of look, you could read what you put and make sure there was no mistake, kind of make sure the sentence structure was o.k. and then write it down. You could also read what the other students were putting down and kind of see how they were making their sentence, where I find F2F you kind of stumble over your words a bit, you get confused sometimes”.</p>	<p>make me nervous seriously and a lot of people are like that too and that might pose a problem but with the chat it is easier. A F2F conversation might be good for those in higher courses”.</p>
---	---

Table 10 shows that NNS appreciated the online chat because they had more time to understand questions asked by others and to think about what to answer. Also, they had time to read what they were writing down before posting it, therefore making answers that were well thought out, more detailed and with a good sentence structure. Chat also allowed them to read what the others were writing and observe their sentence structure. The next most commonly raised topic was about freedom. Students felt more at ease expressing their opinions because of the absence of the interlocutors. Students mentioned that they felt less pressure, they were not worried about being judged. Chat made them less nervous than if they were face-to-face with their interlocutors. These results are similar to those of previous research studies that have found that this environment lowers learners’ inhibitions and leads to more language production and to output that is syntactically more complex than in face-to-face interactions (Kern, 1995; Payne & Whitney, 2002; Waschauer, 1996).

## *2. Negative Aspects of Tool in Post-Study Questionnaires*

The difficulty to meet at the same time online was the most mentioned in the answers on the open-ended question “What did you dislike the most about the exchange?” of the post-study questionnaires (58%). Several students mentioned that trying to arrange a time to meet online with everyone was frustrating. Students were left with the responsibility to agree on a time to meet every week for the online chat. The fact that both groups of students were in a different time zone added some difficulty to the planning. Also, university students have a busy schedule with courses, work and other activities that made it difficult to find a convenient time for all the students in the group. Other factors such as how each student applied themselves in their studies could also have added to the frustration some students felt. This process could surely be made easier by offering students more support in the planning, for example, a schedule could be posted online for students to sign in.

The other answers that came up more than once were related to three general aspects: 1) students found it difficult to discuss with more than one person at the time (16%); 2) they had problems typing fast enough to keep up with topic changes (11%); and 3) they found that the exchange was a burden because it had to be done regularly outside class time (16%). The size of the group could be considered to be smaller or even bigger depending on the objectives to be reached. It was decided with the instructors that groups of four would be ideal to ensure a flow in the discussion, to provide a certain level of comfort zone for all the participants and to make sure that if one participant could not make it, there were enough of them to have a discussion. It is easy to imagine that for some participants, it was overwhelming to interact with three other people at the same time. Some students might not have been as used as others to interact in this environment and the fast pace of chat might have prevent them to express all their ideas. For

students who do not type fast or for students who needed more time to think about their answers, this environment might not be ideal. Instructors might need to discuss this matter with their students to find out their level of comfort with this environment and involve them in the decision about group size. Finally, even though the exchange was integrated to fit with the general objectives of the course, it was added to the existent curriculum and was expected to be done entirely outside classroom time. This aspect is related to the planning of the exchange and is discussed further later in the discussion on participation.

The results related to the CMC aspect show that online chat offered characteristics that have facilitated NNS' use of their L2. Regarding the sociolinguistic competence, these results suggest that some characteristics of the online discussions may facilitate the acquisition of this competence when compared to face-to-face discussions. As explored in previous research studies, the fact that chat is similar to an oral conversation in slow-motion is advantageous for L2 learners (Beauvois, 1992; Payne & Whitney, 2002). In the case of sociolinguistic elements, NNS had more time to make sense of the new forms they were exposed to and to respond to them. The fact that these forms are in writing may also facilitate their acquisition. Moreover, the freedom felt by NNS in the exchange may also be beneficial for the development of sociolinguistic competence because they will have more willingness in trying new linguistic forms.

#### *D. Discussion*

As it was discussed in chapter two, previous research has shown that the sociolinguistic competence develops when L2 learners are exposed to “informal contact with the target language, both through native-speaker contact in general and, more particularly, in the target-language community” (Howard, 2006, p. 381). Also, MacFarlane (2001) showed that the

creation of social relationships between learners of French as a L2 from Ontario and NS from Quebec motivated learners to attempt a more “native-like” performance.

So, what do the results of this section mean in regards to the second research question? Which characteristics of the intercultural CMC exchange as a language practice may support the development of the sociolinguistic competence? First, this environment allowed students to have an informal contact with the target language. In the chat sessions, NNS were exposed to the vernacular style used by NS. It means that chat can serve exactly for this purpose. In this study, NNS did notice the different language style used by NS and it is assumed that a prolonged contact would have led them to incorporate new linguistic forms in their discourse.

Moreover, the NNS affirmed that the NS supported them in the learning of new vocabulary and expressions. Although this research study did not investigate thoroughly how NS provided support to NNS, it investigated negotiation of meaning and found very few instances of this process in the discourse of participants. It was suggested that support was provided in an indirect way through the construction of a collective meaning in the on-going discussions. Indeed, the specific context of an online chat session in a group composed of two language learners and two NS seem to provide an effective vehicle for communication flow while maximizing the chance for language learners to participate in meaningful discussions that are perhaps exceeding their own level of proficiency. This characteristic of chat also seems beneficial to the development of their sociolinguistic competence. As discussed previously, it allows learners to be exposed to sociolinguistic elements in an authentic social context and to participate in meaningful discussions without being limited by their knowledge of their L2. More research studies are needed to understand the different factors that can support learners in an intercultural CMC exchange.

Second, in regards to cultural contact, this context of communication seemed to put forward the facet of “culture as individual” of the culture concept as described by Levy (2007). Indeed, in this context, participants were exposed to multiple and variable views on culture as the direct contact encouraged them to share their personal views and understandings of their culture. Levy explains that culture learners need to be exposed to direct and indirect contact with the target culture that will provide them with patterns of the culture as a whole and also with individual interpretations. In brief, by engaging in the online exchange, learners were encouraged to share their personal views on culture and to connect on a personal level with their NS partners. This aspect of the exchange may be beneficial to the development of sociolinguistic competence as the existence of social bonds may motivate L2 learners to adopt more “native-like” forms (MacFarlane, 2001) to identify with the target-language community (Dewaele, 2004).

Third, the NNS acknowledged that online chat gave them more time to process the questions and to prepare their answers. Chat also made it possible for them to read what the other participants were saying and to observe their choice of sentence structure and words. These specific aspects seem to agree with the idea that online chat is a possible “cognitive amplifier” (Warschauer, 1997). The results confirm the view that online chat, because of its nature as “conversation in slow-motion”, has specific advantages for language learners and for the development of the sociolinguistic competence. The slowness of the interactions may help learners in making sense of the new forms they encounter in the exchange and to process them.

Finally, NNS felt no pressure in getting everything right because of the relaxed environment provided by the online chat. Previous research studies have shown that CMC reduces shyness (Chun, 1994; Warschauer, 1996) and promotes risk-taking and creativity with

the L2 (Meunier, 1998). This characteristic may facilitate the acquisition of new linguistic forms from the informal register by encouraging L2 learners to try out these new forms.

In conclusion, in response to the second research question, several characteristics of the language practice of the intercultural CMC exchange may facilitate the development of the sociolinguistic competence. The strength of this learning environment resides in the ability for NNS to engage in meaningful discussions with NS without being restrained by their level of competency and to build social relationships with members of the target cultural group. The freedom felt by participants in the expression of their opinions led to the development of meaningful connections between participants. Moreover, chat as a “cognitive amplifier” and as a “focus on meaning” medium, combined with the support of the constructed collective meaning, facilitated the comprehension and production of language for NNS. In brief, the intercultural CMC exchange has provided NNS a rich learning environment in which language and culture were linked.

#### *E. Discussion on Participation*

Bearing in mind the fact that half of the groups did not complete all the required tasks, it is important to consider other factors that might have influenced these students' full participation besides the negative aspects of the tools used. It is possible that the instructors had a different approach towards the importance of participating in the exchange. If one group was less motivated than the other and not as eager to meet with the members of their group, it could have created frustration. The goals of the exchange were maybe not clear for some students and this could also have affected their participation. In her study on factors that promote “high group functionality” and “low group functionality”, Belz (2001) describes this aspect as the importance of having correspondence between “classroom scripts”. Specifically, she described the

importance for each group to have learning objectives integrated in the course with the same weight marks and to be supported in the same way by their instructor in reaching these objectives.

Surely, the fact that the exchange was added to the existent curriculum and not fully integrated had an impact on the motivation of some participants. Efforts were put towards making sure that the exchange was integrated as much as possible to the objectives of the course, but it was still a research project added by an external party (the researcher) to the existent course curriculum. This means that because it was not the initiative of the instructor, the pedagogical support might have lacked before, during, and after the exchange. No doubt that such an exchange requires a lot of support from the instructor.

First, participants might have needed support at the technical level of the activity. Therefore, the instructor should have been able to assist them and to answer questions related to the technical aspect. In this study, both instructors had a demonstration session with the researcher. The NNS group received a demonstration session given by the researcher and the NS group by their instructor. However, after this initial information session, participants were mostly left to deal with any technical problems on their own. If the exchange was an initiative of the instructors, support had this level would probably have been more effective.

Second, participants might have needed reinforcement regarding the learning objectives of the exchange and needed discussions in class about their learning experience during the exchange. The results presented in this study suggest that NNS gained linguistic and cultural knowledge by interacting online with NS. The exchange contained many layers that could have been exploited further in class with the instructor. It is difficult to know what exactly happened at this level in the respective classes, but because this activity was added to the existent

curriculum, it is not hard to imagine that reinforcement was limited. In consequence, students might have felt that the activity was not as important as others and might have lacked motivation.

The success of such an exchange not only depends on its integration into the curriculum; it also depends on the quality of the learning activities designed. In this research study, the activities were designed based on sociocultural theory which recognized that use and learning are inseparable and that consciousness emerges from practice (Magnan, 2008). It was assumed that if the exchange allowed L2 learners to be exposed to the informal register used by NS, it would be beneficial to their sociolinguistic competence. Seen through the lens of activity theory, which is a primary component of sociocultural theory, the activities were designed to form the “center of learning”. Lantolf and Thorne (2006) explain that according to activity theory, “the context is not a setting within which activity takes place, rather it is activity that produces the very arena of human conduct” (p. 215). In this research study, activities were specifically designed to facilitate learning through the act of participants engaging in the assigned tasks. The technology was the means by which the participants could interact with each other, but it was by engaging in the activity that students were expected to learn.

Activity theory also recognized that learners “involved in the same task are necessarily involved in different activity because they bring their unique histories, goals and capacities” (Roebuck, 2000, p. 79). It means that tasks are accomplished by learners in different ways and that different interpretations of the task lead to different learning. Besides individualization in how the activity was realized, other layers may have influenced participation. The intercultural exchange involved the creation of a community of learners by means of technology where co-construction of meaning and identity occurred (Magnan, 2008). It means that L2 learners were exposed to speakers of the target culture with whom they were trying to create meaning and

relationships in an environment different from the typical classroom. Through this process, their identity was evolving. In brief, such a practice requires instructors to acknowledge all the different layers involved and to support the development of knowledge at all these levels while being an “expert” of the target culture. Because the intercultural exchange was not fully integrated in the curriculum of the course, this kind of support was not provided to the learners. Without this support, participants might have felt as if the learning activity was not complete, was missing some parts, and this might have affected their motivation to participate.

All the factors discussed above should be taken into consideration in the planning of such an exchange. Some of these factors are discussed further in the pedagogical implications section of the conclusion.

## VI. Conclusion

This study used online text-chat and a discussion forum to further examine the characteristics of this environment for the development of the sociolinguistic competence of L2 learners involved in exchanges with NS. The sociolinguistic competence involves the knowledge and skills required to deal with the social dimensions of language use such as the choice and use of words for greetings. Since few studies on CMC have addressed the potential that these technologies hold for developing an aspect such as the sociolinguistic competence, it was also seen as an opportunity to contribute something new and relevant to the current body of literature on CMC technologies.

The data of this research study consisted of the online interactions, pre and post-study questionnaires and individual interviews. A qualitative analysis of these data was intended to answer two main research questions. First, did the intercultural CMC exchange provide the conditions necessary for the development of the sociolinguistic competence of non-native speakers? Second, what characteristics of the intercultural CMC exchange as a language practice may support the development of the sociolinguistic competence?

### *A. Summary of Findings*

#### *1. Sociolinguistic Competence*

The qualitative analysis of the chat exchanges showed that in this online environment, participants use many of the sociolinguistic elements as described in the European framework (CEFRL) used to guide the analysis. It was found that in the chat sessions, participants used greetings on arrival and on departure, address forms, expletives, markers of politeness, and an informal register.

As expected, the aspects that were most problematic for the NNS were related to the lack of knowledge of the informal register. This was shown in their use of words for greetings and for expletives that were more formal than the ones used by NS. NNS also lacked strategies to modulate their speech and they referred most of the time to the expression “je pense que”... (I think that) while NS used other strategies such as adding the word “generally” to their ideas.

When looking closer at the interactions, a few changes were observed in the discourse of NNS over the duration of the exchange. Indeed, some NNS were sensitized to the different ways NS used greetings, expletives and strategies to modulate their speech and added some of these forms in their discourse. Not many changes were noticed in the discourse of the NNS and I suggested that more time was needed for them to “proceduralise” the new sociolinguistic knowledge. I concluded that this online environment was conducive to the development of the sociolinguistic competence. Without a doubt, NNS were exposed to new forms and were pushed to make sense of them to participate in the discussions.

## *2. Characteristics of Language Practice*

Regarding the characteristics of the language practice, a majority of NNS saw the exchange as beneficial in some ways to their linguistic development and few important themes emerged from the results. First, NNS recognized this exchange as a unique opportunity to practice their L2 with NS outside the classroom. Second, they acknowledged the support provided by NS as important in the development of the discussions. It was suggested that this support was provided in an indirect way by the construction of a collective meaning through the on-going discussion. Third, NNS said that they had an increase in their confidence in talking in French. It was suggested that this environment facilitated the expression of their ideas by emphasizing a focus on the meaning of the message rather than on the form. NNS were able to

participate in meaningful interactions in their L2 at a level that surpassed their own level of proficiency and this increased their level of confidence. These conditions seem to be ideal for the development of the sociolinguistic competence because language learners are encouraged to use new linguistic forms and the comprehension of new words or idiomatic expressions is supported by the collective meaning developed by the participants of a group.

As regards to cultural contact, NNS appreciated the opportunity to interact with people in Quebec and to learn about different cultures, views and opinions. Most importantly, it was observed that in the discussions on cultural topics, participants talked about their personal backgrounds and experiences and that the exchange brought forward the facet of “culture as individual” of the cultural concept as described by Levy (2007). Participants shared their personal views and understandings of their culture and they were able to create meaningful social relationships by opening to others. This aspect of CMC seems to facilitate the development of the sociolinguistic competence. Indeed, as suggested by Tarone and Swain (1995), L2 learners have the desire to use a language style “that marks the users as members of a close sub-speech community” (p. 168). So, it is suggested that the closer L2 learners become to their partners, the greater their desire become to be a member of their speech community. Results suggest that such an exchange could allow the creation of the bonds needed for L2 learners to be motivated to learn and use the language forms used by NS.

Results on the CMC aspect have shown that the NNS appreciated the fact that in an online discussion, they have more time to think about the question and their answer than in a face-to-face discussion. They had more time to choose the appropriate words and to form their sentence. The fact that they had more time to prepare their answer combined with the physical absence of the interlocutors made it easier to express their ideas and less stressful than being

face-to-face. Finally, they recognized that in chat, the focus was on meaning and not on the form of the message, so they did not feel the pressure to write perfect grammatical sentences. To summarize, the time delay, the absence of the interlocutor and the focus on meaning made for a learning environment that the NNS described as “relaxed” and “fun” amongst other qualities.

The results related to the characteristics of this language practice add to the body of literature on CMC and language learning. They reinforced what has been found previously on how this language practice can support learners in different ways by providing conditions that promote language learning (Kelm, 1996). The NNS involved in this exchange were able to engage in meaningful discussions and to create social relationships with speakers of the target language. In these exchanges, they saw how NS used language in two different contexts, so they were able to compare two registers. The slowness of the chat allowed them to notice forms used by NS and to make sense of the new forms. Moreover, the support provided by the collective meaning of the on-going discussion allowed L2 learners to communicate successfully with NS. In brief, in relation to the second research question, it was concluded that the characteristics of this language practice offer valuable support for the development of the sociolinguistic competence.

Figure 8 gives an overall picture of the elements that were found to have a positive impact on the sociolinguistic competence of learners in this study.

Figure 8 *Overview of Factors Supporting the Development of Sociolinguistic Competence*

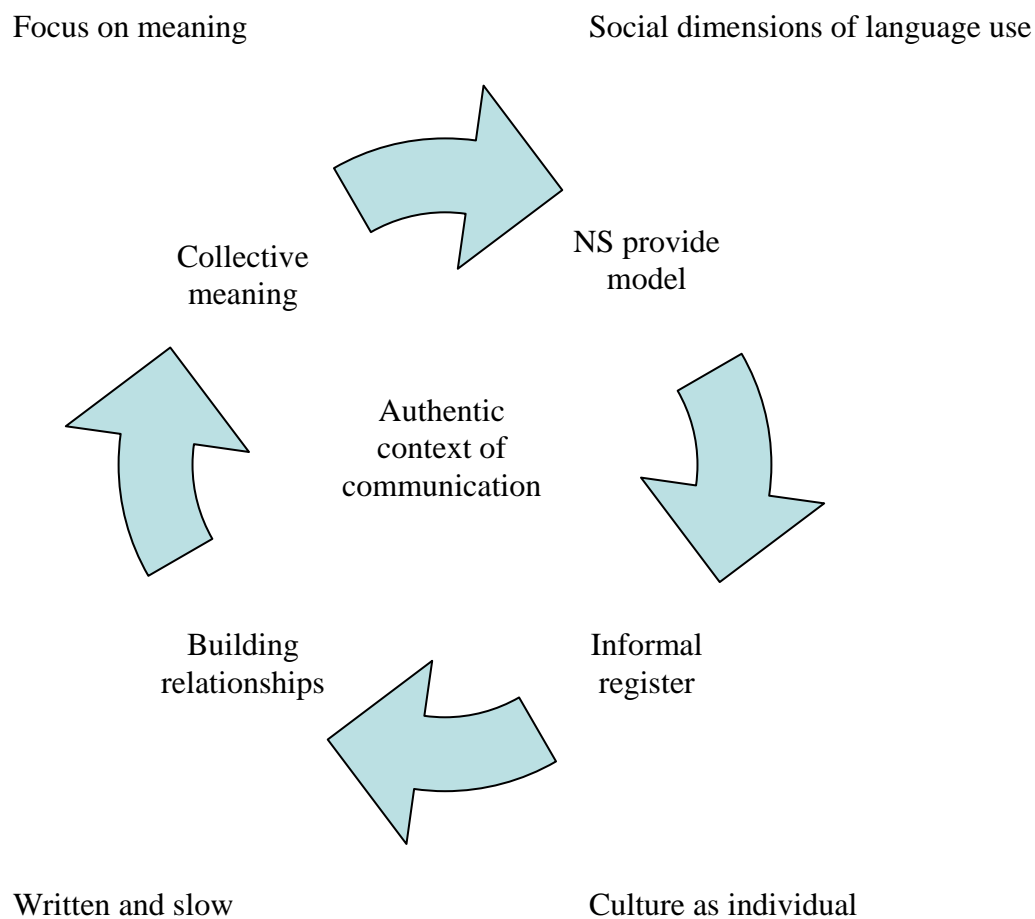

In conclusion, many factors of the intercultural exchange can have a positive impact on the sociolinguistic competence of language learners. Moreover, it is the dynamics of all the factors involved in the online interactions that will support learners in the development of this competence.

### *B. Pedagogical Implications*

The intercultural CMC exchange analyzed in this study was initiated by the researcher and organized in concert with the instructors of the respective course. Being a third party made

the organization of the learning objectives and activities a little more difficult. This also had an impact on the integration of the activity to the existent curriculum. The importance of fully integrating the activity to the objectives of the course was discussed thoroughly in a previous section. This aspect was presented as one of the most probable causes to explain the lack of participation of some students.

However, the observations that were made in groups that participated well can serve as indicator of the sociolinguistic elements that can be expected to be found in a “functional” chat exchange. These elements are presented in Figure 9.

Figure 9 *Sociolinguistic Elements to Expect in Chat Exchanges of Functional Groups*

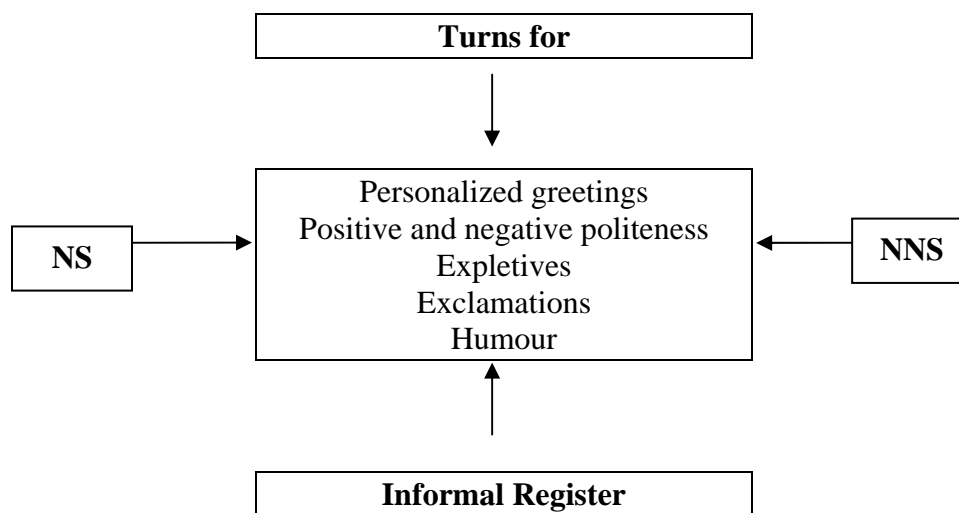

The groups that functioned well were characterized in particular by the high number of turns used to express positive politeness such as showing interest in each others’ well-being and in each others’ ideas and opinions. There were also a high number of turns used for humour and lots of exclamation points added to their discourse. The elements presented in figure 9 seemed to provide an atmosphere conducive to discussions. L2 educators wanting to do a similar project could encourage their students to use these elements. For example, they could show an excerpt of

such a group to their students before they start an exchange and explain that these behaviours create a friendly atmosphere.

The model used to guide this research study, *The Common European Framework of Reference for Languages* (Council of Europe, 2001), was helpful in a sense that it had the most detailed description of the elements that instructors should consider when working on the sociolinguistic competence. However, it was not designed for an online environment or for the learners of French in the Canadian context. This research study was concerned with the learners of French in Canada who do not have easy access to native speakers in their nearby community and who have been known to have a lack in their sociolinguistic competence when interacting with NS in informal situations. The results of this study show that chat allows L2 learners to have access to the informal register and to be exposed to most of the elements presented in the CEFRL. Based on the results, suggestions for learning objectives adapted to these learners and to the online environment can be put forward. Table 11 presents a table which outlined the main objectives that can be reached in this type of exchange.

Table 11 *Learning Objectives for the Development of Sociolinguistic Competence with Intercultural CMC Exchange*

---

Learning objectives
<p>Students will learn:</p> <ol style="list-style-type: none"> <li>1) To greet on arrival and departure in an informal way</li> <li>2) New words and expressions for expletives</li> <li>3) To use the appropriate pronouns of address “tu” (singular) and “vous” (plural)</li> <li>4) Different ways to express positive politeness</li> <li>5) To use humour</li> <li>6) Different strategies to express negative politeness</li> <li>7) Idiomatic expressions and other linguistic forms from the informal register</li> </ol>

---

Table 11 shows that instructors setting up an online exchange with a group of NS can expect to work on many aspects of the sociolinguistic competence. Some elements of the CEFRL are not part of this table because the online environment did not foster their use or because they did apply in a different way in this context. This is the case of the conventions for turn-taking, appropriate use of “please” and “thank you”, impoliteness, and expressions of folk-wisdom. The learning objectives are also more condensed because it focuses on being exposed to an informal register rather than to a variety of registers.

It was discussed previously that the exposure to the informal register should have come with support by the instructors during the exchange. Not only would this support have motivated learners to be involved in the exchange but it could also have reinforced what they were

experiencing. Based on these observations, recommendations can be done for the planning of a similar exchange. Table 12 presents an overview of these steps.

Table 12 *Planning of Intercultural CMC exchange with Focus on Sociolinguistic Competence*

Steps for Instructor
Before the exchange
1. Find a class for the exchange
2. Choose learning objectives and design learning activities
3. Meet with the technical support staff
4. Explain learning objectives and learning activities to students
5. Provide support to students in the planning of time for online discussions with partners
During the exchange
6. Ask students to take note of the different linguistic forms they encounter
7. Provide an online space for sharing new linguistic forms
8. Provide learning activities in class on informal linguistic forms
After the exchange
9. Provide follow-up activities

### *1. Before the Exchange*

Instructors and researchers that have experience with this type of learning activity know the importance of the planning steps. In an exchange involving NNS and NS, the learning objectives will probably not be the same for each group but instructors should agree on the importance that the activity will take in their class. Each group should have learning objectives

integrated in the course with the same weight marks and should be supported in the same way by their instructor in reaching these objectives. Some sites are designed to help instructors in finding class for an exchange. One of these sites is “The MIXXER” host by Dickinson College in Pennsylvania (<http://www.language-exchanges.org/>).

With the objectives of foreign language learning slowly changing from a focus on communicative competence to a focus on intercultural competence, it should be easy for instructors to agree on cultural goals. In general, the goals of such exchange include “aspirations of linguistic and pragmatic development as well as increasing awareness of one’s own cultural background, those of one’s interlocutors, and the processes involved in carrying out extended, productive, and ultimately meaningful intercultural dialogue” (Thorne, 2005, p. 3). Cultural objectives could be the common ones between groups. The NS group could also include future L2 instructors wanting to apply what they have learned or wanting to observe and support L2 learners in their progression. Perhaps this could be the ideal group because they could support NNS in the reaching of the sociolinguistic objectives. They could also take part in the reaching of specific objectives for NNS by participating in other learning activities. For example, they could participate in the building of a corpus in an online space by writing expressions used in day-to-day conversation with their peers. One can imagine that discussions on this aspect could take place between both groups during and after the exchange. This way, both groups would benefit from the exchange in regards to the sociolinguistic aspect.

As soon as the instructors have an idea of the design of the project and on the computing tools that will be required, they should meet with the technical support staff of their faculty. The support staff will determine the feasibility, the scale, and nature of the proposed project, and will suggest what to do next. This step is very important because the staff will inform instructors on

the existing hardware, software and infrastructure within the university, and guide them in the choice of the appropriate tools. In general, support staff will offer help with planning and managing a project. Instructors should work closely with the support staff and be prepared for any technical difficulties that will affect the project.

Instructors should also think about a way to support students in the setting of their online meeting to avoid students' frustration. For example, groups could be formed based on students' availability. An online space could be provided where students could post different times of the week when it is convenient for them to meet and groups can be formed based on this information. This could be a step that requires lots of logistic but once the schedule would be done, students would have to respect it and it could avoid many frustrations. Finally, students should be conscious of the learning objectives of the exchange and encouraged to work towards reaching these objectives by instructors.

## *2. During the Exchange*

NNS should be encouraged to notice and take notes when they encounter new linguistic forms from the informal register. They could write them down in a journal to be shared in class with the others. The instructor would provide them with explanations about these forms regarding meaning and usages. Another way to do this would be to provide an online space where students would write the new forms they encounter. This "space" could be easily added to the platform used for the exchange. This could allow all students to share and comment on these forms and give time to the instructor to choose the elements to discuss in class afterwards.

Instructors could also choose extracts of the exchange to study and illustrate some specific aspects of the sociolinguistic competence. For example, an extract could be used to compare NNS and NS' usages of expressions of negative politeness. This method was used by

Belz and Vyatkina (2005) for the teaching of German modal particles. In the conclusion of their study, they suggest that the alternation between online sessions and classroom sessions where students examine their own use of these particles as well as that of their NS key pals may foster the type of noticing required for L2 development.

### *3. After the Exchange*

After the exchange, instructors should provide time for students to reflect on their experience and to share it with others. They could encourage students to stay connected with their partners and to continue their interactions on their own. Instructors could expose students to other material using an informal register such as extracts of movies, audio clips and TV shows. Students could be asked to analyze this material and discussions could take place in the classroom based on their observations.

### *C. Directions for Further Research*

This study showed that an intercultural CMC exchange offers conditions that may contribute positively to the development of NNS' sociolinguistic competence. Further research is needed to establish which factors could maximize the development of this competence. For example, research could determine the type of explicit instruction to be provided during the exchange to maximize students' development. More research is also needed to further our understanding on how NS and the building of a collective meaning support NNS in their development.

Research studies could also look at how L2 learners perceived the use of other registers other than the neutral and the formal register. For example, is there a certain confidence level that L2 learners need to achieve before they decide to integrate more idiomatic forms in their

discourse? Or, is there a certain degree of relationship that has to be reached before learners want to identify with the speakers of the target community or before NS accept NNS as parts of their in-group?

It would also be interesting to see how online interactions with NS compare to face-to-face interactions with NS in regards to the development of sociolinguistic competence of NNS. For example, does it have the same beneficial effect on learners? Does it need to last longer to have the same beneficial effect?

In addition, it would be most interesting to see if learners who show an improvement in their sociolinguistic competence in an online text-chat could transfer their competence to an oral conversation. This is one interesting question that applies to other communicative practices encouraged by CMC as to whether “they are internalized and are in turn redeployed in face-to-face interactions or in other communicative genres (Lantolf, 2002, p. 112).

#### *D. Final Conclusions*

To conclude this study, it is important to remember that for many language learners, the ultimate goal to reach is to be able to communicate successfully with NS in natural contexts. This successful communication involves the knowledge of vocabulary and grammar rules but it also involves “when, and why to say what to whom” (ACTFL, p.3). Language learners’ ultimate interaction with NS would be a situation where they can use the words the same way they do in their first language. For example, in an interaction with a peer in an informal setting, a language learner might want to use humour and tease his or her interlocutor by choosing appropriate words which are more than likely of an informal register. Moreover, language learners want to use the words the same way NS do in a specific context and want to “blend in” the communicative situation. This requires the development of the sociolinguistic competence that

will improve with exposition to the various registers available in written and spoken forms of the target language (Nadasdi, Mougeon & Rehner, 2005) and most importantly with authentic use of the L2 with NS (Dewaele, 2004).

This study proposes that contact with NS by way of new communication technologies is one way of solving the question of how to teach sociolinguistic competence in the L2 classroom. With online text-chat, students have an opportunity for authentic communication with NS and exposure to a variety of language that is not accessible in the classroom. This study will add to a growing body of research on CALL and more specifically on research involving CMC exchange between NS and NNS. It is hoped that it will also support language educators interested in the teaching of sociolinguistic competence.

In more general terms, the study aimed to emphasize the importance of contact with the target language and culture in the development of language learners' skills. Besides the reasons mentioned above, "contact experiences may encourage learners to attempt more native-like use of the L2, motivate them to seek interaction opportunities outside the classroom, and help them to integrate their L2 into their lives in the future" (MacFarlane, 2001). Moreover, with the recognition of language learning as a linguistic process as well as a social process, authentic contact with NS becomes essential. It is by interacting with NS, who will provide support in the construction of a collective meaning, that language learners will develop the competencies necessary to communicate successfully. This contact with NS also involves exposure to the target culture that is authentic and becomes accessible through CMC. In summary, this dissertation aspired to show that intercultural CMC exchange provides a rich learning environment where the natural forces of a community of practice mediate language acquisition. In this environment, language learners have the possibility of developing linguistic precision,

sociolinguistic competence, and intercultural competence through the construction of relationships with other social groups beyond their own.

## References

- Abrams, Z. I. (2003). The effects of synchronous and asynchronous CMC on oral performance in German, *The Modern Language Journal*, 87(2), 157-167.
- Abrams, Z. I. (2006). From theory to practice: Intracultural CMC in the L2 classroom. In L. Ducate & N. Arnold (Eds.), *Calling on CALL: From theory and research to new directions in foreign language teaching* (pp.181-210). Texas: CALICO Monograph Series.
- American Council on the Teaching of Foreign Languages. (1999). *Standards for foreign language learning in the 21st century*. Yonkers, NY: ACTFL.
- Arnold, N., & Ducate, L. (2006). CALL: Where are we and where do we go from here? In L. Ducate & N. Arnold (Eds.), *Calling on CALL: From theory and research to new directions in foreign language teaching* (pp.211-236). Texas: CALICO Monograph Series.
- Atkinson, D. (2002). Toward a sociocognitive approach to L2 acquisition. *The Modern Language Journal*, 86(4), 525-545.
- Bachman, L. F. (1990). *Fundamental considerations in language testing*. Oxford : Oxford University Press.
- Ballou, E. G. (2002). *Teaching language and culture with computer-mediated communications technologies*. Unpublished doctoral dissertation, University of Massachusetts-Amherst.
- Beauvois, M. H. (1992). Computer-assisted classroom discussion in the foreign language classroom: Conversation in slow-motion. *Foreign Language Annals*, 25(5), 455-464.

- Beauvois, M. H. (1997). Computer-mediated communication: Technology for improving speaking and writing. In M. Bush (Ed.), *Technology enhanced language learning* (pp. 165-184). Lincolnwood, Illinois: National Textbook Company.
- Beauvois, M. (1998). Write to speak: The effects of electronic communication on the oral achievement of fourth semester French students. In J. A. Muyskens (Ed.), *New ways of learning and teaching: Focus on technology and foreign language education* (pp. 93-115). Boston: Heinle & Heinle.
- Bell, N. D. (2005). Exploring L2 language play as an aid to SLL: A case study of humour in NS –NNS interaction, *Applied Linguistics*, 26(2), 192-218.
- Belz, J. A. (2001). Institutional and individual dimensions of transatlantic group work in network-based language teaching. *ReCALL*, 13, 213-231.
- Belz, J. A. (2002). Social dimensions of telecollaborative foreign language study. *Language Learning & Technology*, 6(1), 60-81.
- Belz, J.A. (2003). Linguistic perspectives on the development of intercultural competence in telecollaboration. *Language Learning & Technology*, 7(2), 68-117.
- Belz, J. A., & Kinginger, C. (2002). The cross-linguistic development of address form use in telecollaborative language learning: Two case studies, *Canadian Modern Language Review*, 59(2), 189-214.
- Belz, J. A., & Müller-Hartman, A. (2003). Teachers as intercultural learners: Negotiating German-American telecollaboration along the institutional faultline. *The Modern Language Journal*, 87(1), 71-89.

- Belz, J. A., & Vyatkina, N. (2005). Learner corpus analysis and the development of L2 pragmatic competence in networked intercultural language study: The case of German modal particles. *Canadian Modern Language Review*, 62(1), 17-48.
- Blake, R. (2000). Computer-mediated communication: A window on L2 Spanish interlanguage. *Language Learning & Technology*, 4(1), 120-136.
- Brown, H. D. (2000). *Principles of language learning and teaching*, New York: Addison Wesley Longman.
- British Columbia Ministry of Education. (1997). *Ensemble de ressources intégrés, Français langue seconde immersion de la maternelle à la 7<sup>e</sup> année*. Victoria : Ministère de l'Éducation et de la Formation professionnelle de la Colombie-Britannique.
- British Columbia Ministry of Education. (2001). *Integrated Resource Package, Core French 5 to 12*, Victoria: BC MOE Curriculum Branch.
- Brandl, K. (2005). Are you ready to “Moodle”? *Language Learning & Technology*, 9(2), 16-23.
- Byram, M. (1997). *Teaching and assessing intercultural communicative competence*. Clevedon, UK: Multilingual Matters.
- Caelli, K., Ray, L., & Mill, J. (2003). “Clear as mud”: Toward greater clarity in generic qualitative research, *International Journal of Qualitative Methods*, 2(2), 1-24.
- Canadian Parents for French, (2004). *The state of French-second-language education in Canada*, Ottawa: Canadian Parents for French.
- Canadian Parents for French (2007), *Intensive French – A British Columbia Perspective*, Canada, Ottawa: Canadian Parents for French Bulletin.

- Chapelle, C. (1997). CALL in the year 2000: Still in search for research paradigms? *Language Learning & Technology*, 1(1), 19-43.
- Chapelle, C. (2006). Interactionist SLA theory in CALL research. In J. Egbert and G. M. Petrie (Eds.) *CALL research perspectives* (pp. 53-64). Mahwah, NJ: Lawrence Erlbaum.
- Chapelle, C. (2008, June). *The spread of computer-assisted language learning*. Invited speaker at the meeting of the Canadian Association of Applied Linguistics, Vancouver, Canada.
- Chun, D. (1994). Using computer networking to facilitate the acquisition of interactive competence. *System*, 22(1), 17-31.
- Council of Europe (2001). *The common european framework of reference for languages*. Cambridge: Cambridge University Press.
- Conelios, T., & Olivia, M. (1993). Using computer networks to enhance foreign language/culture education. *Foreign Language Annals*, 26, 527-534.
- Cook, G. (1989). *Discourse*. Oxford: OUP.
- Coulthard, M. (1977). *An introduction to discourse analysis*. London: Longman.
- Davis, B., & Thiede, R. (2000). Writing into change: Style shifting in asynchronous electronic discourse. In M. Warschauer, & R. Kern (Eds.), *Network-based language teaching: Concepts and practice* (pp.87-120). Cambridge: Cambridge University Press.
- Dewaele, J.-M. (2004). The acquisition of sociolinguistic competence in French as a foreign language : An overview. *French Language Studies*, 14, 301-319.

- Dewaele, J.-M., & Reagan, V. (2002). Maîtriser la norme sociolinguistique en interlangue française: Le cas de l'omission variable de « ne ». *Journal of French Language Studies*, 12, 123-148.
- Ellis, R. (1999). *Learning a second language through interaction*. New Zealand, Auckland: John Benjamin Publishing Company.
- Furstenberg, G., Levet, S., English, K. & Maillet, K. (2001). Giving a virtual voice to the silent language of culture: The CULTURA project. *Language Learning & Technology*, 5(1), 55-102.
- Gass, S. M., & Selinker, L. (2001). *L2 acquisition: An introductory course* (2<sup>nd</sup> ed.). Mahwah, NJ: Lawrence Erlbaum.
- Gray, R., & Stockwell, G. (1998). Using computer mediated communication for language and culture acquisition. *On-CALL*, 12(3), Retrieved Avril 5, 2008, from <http://www.cltr.uq.edu.au/oncall/gray123.html>
- Hanna, B. E., & de Nooy, J. (2003). A funny thing happened on the way to the forum: Electronic discussion and foreign language learning. *Language, Learning & Technology*, 7(1), 71-85.
- Hertel, T. J. (2003). Using an e-mail exchange to promote cultural learning. *Foreign Language Annals*, 36(3), 386-396.
- Hinkel, E. (2001). Building awareness and practical skills for cross-cultural communication in ESL/EFL. In M. Celce-Murcia (Ed.), *Teaching english as a second or foreign language* (pp. 443-458). Boston, MA: Heinle & Heinle.
- Howard, M. (2006). Variation in advanced French interlanguage: A comparison of three sociolinguistic variables. *The Canadian Modern Language Review*, 62(3), 379-400.

- Hymes, D. (1967). *On communicative competence*. Unpublished manuscript, University of Pennsylvania.
- Kelm, O. R. (1996). The application of computer networking in foreign language education: Focusing on principles of L2 acquisition. In M. Warschauer (Ed.), *Telecollaboration in foreign language learning: Proceedings of the Hawai'i symposium* (pp. 19-28). Honolulu: University of Hawai'i L2 Teaching and Curriculum Center.
- Kern, R. (1995). Restructuring classroom interaction with networked computers: Effects on quantity and characteristics of language production, *The Modern Language Journal*, 79(4), 457-476.
- Kern, R. (1996). Computer-mediated communication: Using e-mail exchange to explore personal histories in two cultures. In M. Warschauer (Ed.), *Telecollaboration in foreign language learning: Proceedings of the Hawai'i symposium*. (pp. 105-119). Honolulu: University of Hawai'i L2 Teaching and Curriculum Center.
- Kern, R. (2000). *Literacy and language teaching*. Oxford: Oxford University Press.
- Kern, R., Ware, P., & Warschauer, M. (2004). Crossing frontiers: New directions in online pedagogy and research. *Annual Review of Applied Linguistics*, 24, 243-260.
- Kern, R., & Warschauer, M. (2000). Introduction: Theory and practice of network-based language teaching. In M. Warschauer, & R. Kern (Eds.), *Network-Based Language Teaching: Concepts and Practice* (pp.1-19). Cambridge: Cambridge University Press.
- Kitade, K. (2000). L2 learners' discourse and SLA theories in CMC: Collaborative interaction in internet chat. *Computer Assisted Language Learning*, 13(2), 143-166.

- Kötter, M., Shield, L., & Stevens, A. (1999). Real-time audio and email for fluency: Promoting distance language learners' aural and oral skills via the Internet. *ReCALL*, 11(2), 55-60.
- Kötter, M. (2003). Negotiation of meaning and code-switching in online tandems. *Language Learning and Technology*, 7(2), 145-172.
- Kramsch, C. (1998). *Language and culture*. Oxford: Oxford University Press.
- Kramsh, C., & S. L. Thorne, (2002), Foreign language teaching as global communicative practice. In D. Block & D. Cameron (Eds.), *Globalization and language teaching* (pp. 83-100). London: Routledge.
- Lam, W.S.E. (2003). L2 literacy and the design of the self: A case study of a teenager writing in the Internet. *TESOL Quarterly*, 34(3), 457-482.
- Lamy, M. N., & Goodfellow, R. (1999). Reflective conversation in the virtual language classroom. *Language, Learning & Technology*, 2(2), 43-61.
- Lantolf, J. P. (2002). Sociocultural theory and second language acquisition. In R.B. Kaplan (Ed.). *The Oxford handbook of applied linguistics*, Oxford: University Press.
- Lantolf, J. P., & Thorne, S. (2006). *Sociocultural theory and the genesis of second language development*. Oxford: Oxford University Press.
- Lee, L. (1997). Using Internet tools as an enhancement of C2 teaching and learning. *Foreign Language Annals*, 30(3), 410-427.
- Lee, L. (2004). Learners' perspectives on networked collaborative interaction with native speakers of Spanish in the US. *Language Learning and Technology*, 8(1), 83-100.

- Levy, M. (2007). Culture, culture learning and new technologies: Towards a pedagogical framework. *Language Learning and Technology*, 11(2), 104-127.
- Lichtman, M. (2006). *Qualitative research in education: A user's guide*. Thousand Oaks, CA: Sage Publications.
- Lincoln, Y. S., & Guba, E. G. (1985). *Naturalistic Inquiry*. Newbury Park, CA: Sage Publications.
- Lodico, M. G., Spaulding, D. T., & Voegtle, H. V. (2006). *Method in educational research: From theory to practice*. San Francisco: Jossey-Bass.
- Lomicka, L. (2001). 'A new perspective on the world' – A qualitative study of learning French in an accelerated language classroom. Unpublished doctoral dissertation, Pennsylvania State University, University Park, PA.
- Lomicka, L. (2006). Understanding the other: Intercultural exchange and CMC. In L. Ducate & N. Arnold (Eds.), *Calling on CALL: From theory and research to new directions in foreign language teaching* (pp.211-236). Texas: CALICO Monograph Series.
- Long, M. H. (1983). Native speaker/non-native speaker conversation and the negotiation of comprehensible input. *Applied Linguistics*, 4(2), 126-141.
- Luke, C. L. (2006). Situating CALL in the broader methodological context of foreign language teaching and learning: Promises and possibilities. In L. Ducate & N. Arnold (Eds.), *Calling on CALL: From theory and research to new directions in foreign language teaching* (pp.21-42). Texas: CALICO Monograph Series.
- Lyster, R. (1994). The effect of functional-analytic teaching on aspects of French immersion students' sociolinguistic competence. *Applied Linguistics*, 15, 263-287.

- MacFarlane, A. (2001). Are brief contact experiences and classroom language learning complementary? *The Canadian Modern Language Review*, 58(1), 64-83.
- MacFarlane, A., & Wesche, M.B. (1995). Immersion outcomes: Beyond language proficiency. *The Canadian Modern Language Review*, 51(2), 250-274.
- Magnan, S. S. (2008). The unfulfilled promise of teaching for communicative competence: Insights from sociocultural theory. In J. P. Lantolf & M. E. Poehner (Eds.), *Sociocultural theory and the teaching of second languages* (pp. 351-381). London: Equinox Publishing.
- Meunier, L. (1998). Personality and motivational factors in electronic networking. In J. Muyskens (Ed.), *New ways of teaching and learning: Focus on technology and foreign language education* (pp. 145-197). Boston: Heinle & Heinle.
- Mougeon, R., Nadasdi, T., & Rehner, K. (2002). Etat de la recherche sur l'appropriation de la variation par les apprenants avancés du FL2 ou FLE. *AILE. Acquisition et Interaction en Langue Etrangère*, 17, 7-50.
- Müller-Hartmann, A. (2000). The role of tasks in promoting intercultural learning in electronic learning networks. *Language Learning & Technology*, 4(2), 129-147.
- National Standards in Foreign Language Education Project. (1999). *Standards for foreign language learning in the 21st century*. Lawrence, KS: Allen Press, Inc.
- Nadasdi, T. Mougeon, R., & Rehner, K. (2005). Learning to speak everyday (Canadian) French. *The Canadian Modern Language Review*, 61(4), 543-563.
- Negretti, N. (1999). Web-Based activities and SLA: A conversation analysis research approach. *Language Learning & Technology*, 3(1), 75-87.

- Office of Commissioner of Official Languages, *The official languages of Canada's population*, Retrieved on May 22, 2008 from [http://www.ocol-clo.gc.ca/html/stats\\_e.php](http://www.ocol-clo.gc.ca/html/stats_e.php)
- O'Dowd, R. (2003). Understanding the "other side": Intercultural learning in a Spanish-English e-mail exchange. *Language Learning & Technology*, 7, 118-144.
- Ommagio Hadley. A. (2001). *Teaching language in context*. (3<sup>rd</sup> ed.). Boston : Heinle.
- O'Rourke, B. (2005). Form-focused interaction in online tandem learning. *CALICO Journal*, 22(3), 433-466.
- Payne, J. S., & Whitney, P. J. (2002). Developing L2 proficiency through synchronous CMC: Output, working memory, and interlanguage development. *CALICO Journal*, 20(1), 7-32.
- Patton, M. Q. (1990). *Qualitative evaluation and research methods* (2nd ed.). Newbury Park, CA: Sage Publications.
- Patton, M. Q. (1992). Ethnography and research: A qualitative view. *Topics in Language Disorders*, 12, 1-14.
- Pellettieri, J. (2000). Negotiation in cyberspace: The role of chatting in the development of grammatical competence. In M. Warschauer, & R. Kern (Eds.), *Network-based language teaching: Concepts and practice* (pp. 59-86). Cambridge: Cambridge University Press.
- Pica, T. (1994). Research on negotiation: What does it reveal about L2 learning conditions, processes and outcomes? *Language Learning*, 44, 493-527.

- Regan V. (1995). The acquisition of sociolinguistic native speech norms: Effects of a year abroad on second language learners of French. In B. F. Freed (Ed.), *Second language acquisition in a study abroad context* (pp 245-267). Amsterdam: John Benjamins Publishing.
- Rehner, K. (2002). *The development of aspects of linguistic and discourse competence by advanced second language learners of French*. Unpublished PhD dissertation. Toronto: OISE/University of Toronto.
- Rehner, K. and Mougeon, R. (1999). Variation in the spoken French of immersion students: To “ne” or not to “ne”, that is the sociolinguistic question. *The Canadian Modern Language Review*, 56, 124-154.
- Roebuck, R. (2000). Subjects speak out: How learners position themselves in a psycholinguistic task. In J. P. Lantolf (Ed.). *Sociocultural theory and second language learning* (pp. 179-196). Oxford: Oxford University Press.
- Salager-Meyer, F. (2002). I think that perhaps you should: A study of hedges in written scientific discourse. In *Functional approaches to written text*. Office of English language programs, Retrieved Mars 21, 2008, from <http://exchanges.state.gov/education/engteaching/pubs/BR/5111FRM.htm>
- Savignon, S. J., & Rothmeier, W. (2004). Computer-mediated communication: Texts and strategies. *CALICO Journal*, 21(2), 265-290.
- Savignon, S. J. & Sysoyev, P. V. (2002). Sociocultural strategies for a dialogue of cultures. *The Modern Language Journal*, 86(4), 508-524.

- Saville-Troike, M. (2003). Extending “communicative concepts” in the L2 curriculum: A sociolinguistic perspective. In D. L. Lange, C. A. Klee, R. M. Paige, & Y. A. Yershova (eds.), *Culture as the core: Integrating culture into the language curriculum* (pp. 1-14). Minneapolis, MN: Center for advanced research on language acquisition.
- Sax, K. (2003). *Acquisition of stylistic variation in American learners of French*. Unpublished PhD thesis, Indiana University.
- Smith, B. (2005). The relationship between negotiated interaction, learner uptake, and lexical acquisition in task-based computer-mediated communication. *TESOL Quarterly*, 39, 33-58.
- Sotillo, S. (2000). Discourse functions and syntactic complexity in synchronous and asynchronous communication. *Language Learning & Technology*, 4(1), 82-119.
- Statistics Canada, *2006 Census*, Official languages, Retrieved on June 22, 2008, from <http://www12.statcan.ca>
- Strauss, A., & Corbin, J. (1990). *Basics of qualitative research: Grounded theory procedures and techniques*. Newbury Park, CA: Sage Publications
- Sullivan, N., & Pratt, E. (1996). A comparative study of two ESL writing environments: A computer-assisted classroom and a traditional oral classroom. *System*, 24(4), 491-501.
- Swain, M. (1985). Communicative competence : Some roles of comprehensible input and comprehensible output in its development. In S. Gass & C. Madden (Eds.), *Input in L2 acquisition* (pp. 235-253). Rowley, MA: Newbury House.
- Swain, M. (2000). French immersion research in Canada: Recent contributions to SLA and applied linguistics. *Annual Review of Applied Linguistics*, 20, 199-212.

- Tarone, E. (2000). Getting serious about language play: Language play, interlanguage variation and L2 acquisition. In B. Swierzbin, F. Morris, M. E. Anderson, C. Klee, and E. Tarone (Eds.), *Social and Cognitive Factors in L2 Acquisition: Selected Proceedings of the 1999 L2 Research Forum* (pp. 31–54). Somerville, MA: Cascadilla Press.
- Tarone, E., & Swain, M. (1995). A sociolinguistic perspective on L2 use in immersion classrooms. *The Modern Language Journal*, 79(2), 166-178.
- Thorne, S. L. (2003). Artifacts and culture-of-use in intercultural communication. *Language Learning & Technology*, 7(2), 38-67.
- Thorne, S. L. (2005). Pedagogical and praxiological lessons from Internet-mediated intercultural foreign language education research. In J. A. Belz & S. L. Thorne (Eds.), *Internet-mediated intercultural foreign language education* (pp. 2-30). AAUSC, Boston: Thomson Heinle.
- Toyoda, E., & Harrison, R. (2002). Categorization of text chat communication between learners and native speakers of Japanese. *Language Learning & Technology*, 6(1), 82-99.
- Tudini, V. (2003). Using native speakers in chat. *Language Learning & Technology*, 7(3), 141-159.
- Varonis, E., & Gass, S. (1985). Non-native/non-native conversations: A model for negotiation of meaning. *Applied Linguistics*, 6(1), 71-90.
- von der Emde, S., Schneider, J., Kötter, M. (2001). Technically speaking: Transforming language learning through virtual learning environments (MOOs). *The Modern Language Journal*, 85, 210-225.

- Vygotsky, L.S. (1986). *Thought and language*. Revised Edition. Cambridge, MA: Harvard University Press.
- Ware, P. (2005). "Missed" communication in online communication: Tensions in a German-American telecollaboration. *Language Learning & Technology*, 9(2), 64-89.
- Warschauer, M. (1996). Comparing face-to-face and electronic discussion in the second language classroom. *CALICO Journal*, 13(1), 7-26.
- Warschauer, M. (1997). Computer-mediated collaborative learning: Theory and practice. *The Modern Language Journal*, 81(4), 470-481.
- Warschauer, M. (2006). Sociocultural perspectives on CALL. In J. Egbert and G. M. Petrie (Eds.) *CALL research perspectives* (pp. 41-52). Mahwah, NJ: Lawrence Earlbaum.
- Zuengler, J., & Miller, E.R. (2006). Cognitive and sociocultural perspectives: Two parallel SLA worlds? *TESOL Quarterly*, 40(1), 35-210.

## Appendixes

### *Appendix A. Topics and Questions Guiding the Online Discussions*

#### **Sujet 1 : Ce qui me définit**

##### Clavardage 1

- Qu'aimez-vous faire dans vos temps libres?
- Discutez de vos goûts musicaux.
- Quelle place la musique occupe-t-elle dans votre vie?

##### Clavardage 2

- Parlez des traditions et des valeurs importantes dans votre famille.
- Parlez des souvenirs de votre jeunesse en rapport avec ces traditions et ces valeurs.
- Discutez des traits de votre personnalité. Ces traits vous ont-ils été transmis par vos parents?

##### Forum

- Quelles sont les valeurs qui vous ont été transmises par vos parents et qui influencent les choix que vous faites dans votre vie?
- 

#### **Sujet 2 : Les voyages et ce qu'ils apportent**

##### Clavardage 1

- Dans quels pays avez-vous voyagé?
- Qu'avez-vous appris lors de votre premier voyage?
- Parlez d'un endroit où vous avez aimé particulièrement voyager.

##### Clavardage 2

- Discutez de cette affirmation : « Les voyages forment la jeunesse ».
- Est-ce que les voyages ont changé votre vie? De quelles façons?
- Parlez des gens que vous avez rencontrés lors de vos voyages. Ont-ils eu une influence sur votre vie?

##### Forum

- Décrivez une aventure ou une expérience que vous avez vécue lors d'un voyage et qui vous a marqué.
-

### **Sujet 3 : Vivre le multiculturalisme**

#### Clavardage 1

- Parlez des difficultés que peut rencontrer une personne immigrant au Canada qui ne parle ni anglais ni français.
- Quelles pourraient être les difficultés rencontrées par un immigrant qui parle anglais ou français mais dont les valeurs culturelles sont totalement différentes des valeurs canadiennes?
- Avez-vous déjà vécu un choc culturel? Quelles ont été vos réactions?

#### Clavardage 2

- Pensez-vous que les Canadiens font en général preuve de tolérance et d'ouverture d'esprit les uns envers les autres?
- Selon vous, est-il possible de vivre avec deux cultures distinctes en soi (culture d'origine et culture canadienne)? Si oui, comment y arrive-t-on?
- Vous êtes-vous déjà senti pris entre deux cultures?

#### Forum :

Comment vivez-vous le multiculturalisme au Canada?

*Appendix B. Form for Participants*

**Nom :** \_\_\_\_\_  
**Login :** \_\_\_\_\_  
**Password :** \_\_\_\_\_

**Nom des personnes dans mon équipe et courriels**

\_\_\_\_\_

\_\_\_\_\_

**Horaire**

<b>Semaines</b>	<b>Activités</b>	<b>Détails</b>
22 au 26 janvier	<b>Courriel</b> : Décider de la date de la 1 <sup>ère</sup> rencontre	
29 janvier au 2 février	<b>Chat 1</b> Date :	<b>Sujet 1</b> <b>Ce qui me définit</b>
5 au 9 février	<b>Chat 2</b> Date :	
12 au 16 février	<b>Paragraphe -Forum 1</b>	
19 au 23 février	<b>Chat 3</b> Date :	<b>Sujet 2</b> <b>Les voyages</b>
26 fév. au 2 mars	<b>Chat 4</b> Date :	
5 au 9 mars	<b>Paragraphe -Forum 2</b>	
12 au 16 mars	<b>Chat 5</b> Date :	<b>Sujet 3</b> <b>Vivre le multiculturalisme</b>
19 au 23 mars	<b>Chat 6</b> Date :	
26 au 30 mars	<b>Paragraphe -Forum 3</b>	

**Évaluation**

**Dans les sessions de clavardage (chat),** vous devrez discuter avec votre groupe pendant **30 minutes**.

Vous devrez aussi écrire un paragraphe de **150 mots** sur les thèmes discutés avec votre équipe. Vous afficherez ce paragraphe dans le **forum** du site.

Tous vos écrits seront lus par votre instructeur et par la chercheuse.

*Appendix C. Pre-Questionnaire on Language Use*

1. How many French courses have you taken at the university level?

---

2. Have you been to any French speaking places? \_\_\_\_\_

If yes, can you provide some detail? (Where, when and for how long?)

---

---

3. What is your first language? \_\_\_\_\_

4. What language(s) do you speak normally at home? \_\_\_\_\_

5. Where and how frequently do you speak French outside this course?

---

6. Are you familiar with online chatting? In what languages? Please, give some detail about your experiences.

---

---

7. Are you familiar with online forum discussion group? In what languages? Please, give some detail about your experiences.

---

---

8. Can you describe three different aspects of French Canadian culture that differs from your own?

---

---

---

---

*Appendix D. Post-Study Questionnaire and Interview*

*Post-Study Questionnaire*

1. What did you like the most about this exchange?
2. What did you dislike the most about the exchange?
3. Please use these lines to comment on any of your above answers that might need further clarification.

*Interview*

1. Did you like the chat to interact in French?
2. What did you think about the chat compared to a face-to-face interaction?
3. Did you use a dictionary while you were doing the exchange?
4. Was a group of four good for you?
5. Did you learn new vocabulary and new expressions? Did you improve your language skills?
6. Do you think you increased your confidence to interact with Francophones in the future?
7. Did you read paragraphs written by other students in the forum? From which group?
8. Did you notice a difference between the language use in the chat and in the forum?
9. Were you able to adapt your language to the chat and forum?
10. Do you think students in Montreal influence your writing in any way?
11. Do you have any other comments about what the exchange brought to your experience as a French language learner?

*Appendix E. Post-Study Questionnaire (Native Speakers)*

1. How long have you been living in Quebec?
2. How long have you been speaking French?
3. Do you consider yourself Francophone?
4. What is your first language?
5. What language(s) do you speak normally at home?
6. Where and how frequently do you speak French outside this course?
7. Are you familiar with online chatting? In what languages? Please, give some detail about your experiences.
8. Are you familiar with online forum discussion group? In what languages? Please, give some details about your experiences.

*Appendix F. Consent Form**Participant Consent Form*

---

**Online Discussions and the Development of Sociolinguistic Competence**

Dear students:

You are invited to participate in a study entitled “**Online Discussions and the Development of Sociolinguistic Competence**” that is being conducted by Ms. Mathy Ritchie. Ms. Ritchie is a graduate student in the department of Curriculum and Instruction at the University of Victoria and you may contact her if you have further questions by telephone at (604) 778-0371 or by e-mail at [mritchie@uvic.ca](mailto:mritchie@uvic.ca).

As a graduate student, she is required to conduct research as part of the requirements for a degree in Educational Studies. It is being conducted under the supervision of Kathy Sanford and Catherine Caws. You may contact Dr. Sanford at (250) 721-7762 and Dr. Caws at (250) 721-7369.

The objective of her research is to give opportunities to students in a French as L2 course and students in a French course to interact in French using modern technology. For this project, students in Vancouver will discuss online with students in Montreal using chat and a discussion forum. These exchanges will allow making connections and enriching respective cultural knowledge. The learning outcomes for students participating in this study are: create with another community; discover their own and the other’s culture; discuss culture in general and expand their horizons; improve their written and cultural competence; and familiarize themselves with the different tools for online discussions.

You are being asked to participate in this study because you are at an age where it is important to make connections with French speaking students from different communities.

If you agree to voluntarily participate in this research, you will:

- 1) Answer anonymously a questionnaire before the project on language uses and computer uses;
- 2) Answer anonymously a questionnaire on your perceptions of learning after the exchange;
- 3) Agree that the online exchanges be used for analysis and research purposes.

Other than the time devoted to participate in the research, we want to assure you that participation in this study will not cause you any inconvenience or risks. Some potential benefits of your participation in this research include increasing your linguistic and cultural knowledge of French and making connections with students from another province in Canada.

Your participation in this research must be completely voluntary. The project will take part in regular class hours and will be directed by your main teacher. The activities you will do outside

the classroom for this project will count towards your final mark for the course. If you agree to participate in the project, the online exchanges and the answers to questionnaires will be used as data by the researcher. Your instructor will not know if you agreed to participate or not in the study so your grades will not be affected by participation. You may withdraw at any time without any consequences or any explanation. If you do not agree to participate or if you withdraw from the study you will still participate in the project but your data will not be used for research purposes.

Both teachers and the researcher will have access to all the exchanges. The instructors will access the online exchanges for course evaluation purposes and the researcher for analysis purposes. The system allowing the researcher to collect the interactions is called Moodle, it's an open source bulletin board package. The system allows setting up administrators that will be able to monitor closely the online interactions. Access to the site will be protected by a password. Once students are on the website, they will have to identify themselves with another password.

Your confidentiality and the confidentiality of the data will be protected. Once the data collected, the names of the students will be changed to fictional names so it will be impossible to identify students. Students will also be recorded during their oral exam (Vancouver students only). The recordings will be transcribed and names will be changed to fictional ones. The researcher will keep all the data collected in a locked filing cabinet and the computer file will be protected by a password. The data will be destroyed after a period of two years. After this period, the transcriptions of the exchanges will be shredded, the recordings erased and the computer files erased.

It is anticipated that the results of this study will be shared with others at a conference in Saskatchewan in May 2007. The researcher will also use the data in her Ph.D. thesis.

Individuals that may be contacted regarding this study include the main researcher and her supervisors (see contact information at the beginning of this form).

In addition, you may verify the ethical approval of this study, or raise any concerns you might have, by contacting the Associate Vice-President, Research at the University of Victoria (250-472-4545) or by e-mail at [ethics@uvic.ca](mailto:ethics@uvic.ca).

Your signature below indicates that you understand the above conditions of participation in this study and that you have had the opportunity to have your questions answered by the researcher.

---

*Name of Participant*

---

*Signature*

---

*Date*

***A copy of this consent will be left with you, and a copy will be taken by the researcher.***