

A COMPARISON OF COGNITIVE AND BEHAVIORAL PROGRAMS
TO PROMOTE THE TRANSFER OF LEARNING
ACROSS EDUCATIONAL SETTINGS
FOR FOUR LEARNING DISABLED CHILDREN

by

DONALD RICHARD FREEZE

B.A., Queen's University, 1971

B.Ed., Queen's University, 1972

A THESIS SUBMITTED IN PARTIAL FULFILLMENT
OF THE REQUIREMENTS FOR THE DEGREE OF

MASTER OF ARTS

in the Department

of

Education

ACCEPTED

ACADEMY OF GRADUATE STUDIES

DEAN

30/08/84

We accept this thesis as conforming
to the required standard

Dr. D.G. Bachor

Dr. C.B. Harvey

Dr. P.O. Evans

Dr. N.I. Mickelson

© DONALD RICHARD FREEZE, 1984

UNIVERSITY OF VICTORIA

August 1984

All rights reserved. This thesis may not be reproduced
in whole or in part, by mimeograph or other means,
without the permission of the author.

Supervisor: Professor Dan G. Bachor

ABSTRACT

With the growth in popularity of special education resource rooms to deliver instruction to learning disabled students, effective means are needed to promote the transfer of academic learning across educational settings. An experimental study is described in which behavioristic and cognitive programs to promote transfer of academic learning across educational settings for four learning disabled children are compared. Three grade four girls and one grade five boy were taught four parallel tasks, on alternate days, in a special education setting. Later, the children's correct responding on a transfer task was recorded in the regular classroom. Each day, for each child, represented a different transfer program. A multi-element baseline design was used over an eight week period to demonstrate differences and similarities between the transfer programs. The results showed that task-specific problem solving

strategies were significantly more effective in promoting transfer than a behavioristic program which involved matching the environmental characteristics across the settings. The contention that the transfer of adaptive classroom behaviors and the transfer of academic learning may be explained and promoted by different factors was supported.

Examiners:

[REDACTED]
Dr. C. B. Harvey

[REDACTED]
Dr. P. O. Evans

[REDACTED]
Dr. N. I. Mickelson

[REDACTED]
Dr. D. G. Bachor

TABLE OF CONTENTS

PRELIMINARY PAGES

Title Page	i
Abstract	ii
Table of Contents	iv
List of Tables	viii
List of Figures	ix
Acknowledgements	x
Dedication	xi

CHAPTER 1	INTRODUCTION	1
-----------	--------------	---

CHAPTER 2	LITERATURE REVIEW	6
-----------	-------------------	---

Types of Transfer	6
Positive and Negative Transfer	7
Vertical and Lateral Transfer	7
Specific and Nonspecific Transfer	9
Near and Far Transfer	10
Literal and Figural Transfer	11
Proactive and Retroactive Transfer	12
Transfer of Training and Learning	14
Interrelationships	16
Summary	20

Theories of Transfer	21
The Theory of Identical Elements	22
The Cognitive Construct Theory	26
The Information Processing Theory	32
Summary	40
Transfer and Special Education	41
Special Education Settings	42
Placement of Children	43
Learning Disabled Children	45
Promotion of Transfer	52
Behavioristic Methods	54
Discriminative stimuli	57
Similar stimulus contexts	58
Matching reinforcement contingencies	60
Sufficient exemplars	63
Programming a breadth of responses	64
Indeterminable or delayed schedules of reinforcement	65
Summary: Behavioristic Methods	66
Cognitive Strategies	68
Self-management	70
Meta-cognitive strategies	71
Causal attributions	73
Multipass	74

	vi
Multiple exemplars	75
Mnemonic strategies	76
Teaching by analogy	77
Summary: Cognitive strategies	77
CHAPTER 3 METHOD	79
Subjects	79
Materials	85
Procedure	86
Design	86
Experimental Conditions	87
Learning Tasks	93
Data Collection	95
Limitations	95
Time	95
Selection	96
Assumptions	96
CHAPTER 4 RESULTS	98
CHAPTER 5 DISCUSSION	107
Interpretation	107
Importance	110

Future Directions	113
Conclusion	114
LITERATURE CITED	115
APPENDICES	129
Appendix A: Protocols	129
Appendix B: Subject Information Form	166
Appendix C: Protocol Record Form	175
Appendix D: Subjects' Schedule	177

List of Tables

- Table 1 Subject Markers
- Table 2 Total Numbers of Correct Responses by Children
in Four Transfer Conditions
- Table 3 Complete Set of Stimulus and Response Items
- Table 4 Problem Solving Strategies

List of Figures

- Figure 1 The transfer hexahedron.
- Figure 2 A graphic comparison of conditions 1 and 2.
- Figure 3 A graphic comparison of conditions 3 and 4.
- Figure 4 A graphic comparison of conditions 2 and 3
and 4.
- Figure 5 A graphic comparison of conditions 1 + 2
and 3 + 4.
- Figure 6 Reward table.
- Figure 7 Illustration of the window card.
- Figure 8 Sample transfer answer sheet for protocols
1, 3 and 4.
- Figure 9 Sample transfer answer sheet for protocol 2.

ACKNOWLEDGEMENT

I would like to acknowledge the help of my committee. In particular, I would like to thank my supervisor for his unfailing support and encouragement.

DEDICATION

To Jieka and my parents...for their love

CHAPTER 1

INTRODUCTION

The transfer of learning from special education settings to regular classrooms for learning disabled elementary school children has increasingly become an area of concern to educators (Keogh & Glover, 1980; Marholin et al., 1976; McLeskey et al., 1980; Stokes & Baer, 1977; Winnet & Winkler, 1972). We do not understand why children receiving special education do not automatically transfer their learning to the regular classroom. That they often do not, however, has been amply documented (Baer & Wolf, 1970; Kanfer, 1971; Koegel & Rincover, 1977; Keogh & Glover, 1980).

The purpose of this thesis was to examine the different effects of some of the variables that might reasonably be thought to influence the transfer of learning process for learning disabled elementary school children.

Transfer of learning is a complicated issue. Several different types of transfer have been differentiated by previous writers. These distinctions have been made within the contexts of two traditions of theoretical development and educational application. The first of these, behaviorism, explains transfer by

means of the theory of identical elements (Osgood, 1949). The second, cognitive theory, has produced two explanations; the cognitive construct theory of transfer and the information processing theory of transfer (Royer, 1979). In addition, a variety of techniques intended to help learning disabled children transfer their learning have been suggested.

To realize the purpose of this study it was first necessary to describe the different types of transfer and organize them into a coherent model. A second step involved an exploration of the theoretical explanations of the transfer process. Together, these first two steps provided a framework for relating transfer of learning theory to special education practice and the performance characteristics of learning disabled children. Finally, it was necessary to consider the techniques intended to promote transfer for learning disabled school children within the contexts of both theory and practice.

Definition. Transfer of learning, with respect to education, refers to the fact that a student's future performance on a given educational task is influenced by his or her history of prior learning.

Educational significance. There are few topics

more central to the educational process than the transfer of learning. It is difficult to imagine an educational task where students' performances will not be influenced by their previous learning. It is equally difficult to imagine a school learning task for which teachers intend no future applications by their students.

Research question. Two contrasting positions as to how to best promote transfer of learning have been introduced. Each position has a basis in theory and is consistent with a reasonable interpretation of previous research efforts.

First, from a behavioristic perspective, the transfer of academic learning is presumed to be dependent upon external environmental factors. Learning disabled children's transfer of trained behaviors across settings has been shown to be dependent upon environmental factors (Karloly, 1980; Marholin et al., 1976; Marholin & Siegel, 1978; Whaler, 1969). These factors include characteristics of the teacher, classroom decor, instructional materials, and teaching procedures (Baer & Wolf, 1970, Griffith & Craighead, 1972; Schwartz & Hawkins, 1970; Walker & Buckley, 1972). In general, it is

presumed that similarities between these factors in the original learning setting and the transfer setting promote transfer. Does this explanation of the transfer of behaviors account for the transfer of learning disabled children's academic learning as well?

Second, from the perspective of cognitive theory, it is presumed that the transfer of academic learning is mediated by internal cognitive processes and not external environmental factors. Several writers have questioned whether cognitive strategies taught at original learning might not provide mediation for the transfer of learning disabled children's academic learning across educational settings (Meichenbaum, 1980; Schumaker et al., 1982; Turkewitz, 1975). Strategies under consideration have included, among others, self-management, general problem solving procedures, and multiple passes through the learning materials (Kanfer, 1971; Meyers & Paris, 1978; O'Leary, 1980; Schumaker et al., 1982). Do internal cognitive processes mediate the transfer of academic learning across educational settings for learning disabled children?

A further variation of these two positions must

also be considered. Past applied research studies, where students' transfer of their academic learning has been promoted by cognitive strategies (Schumaker et al., 1982; Turkewitz, 1975), have involved the use of behavioral techniques to establish and support the transfer process. Is it possible that cognitive strategies promote the transfer of academic learning across educational settings for learning disabled children only when those strategies are associated with the environmental factors that promote transfer?

In general terms, the research question asked in this thesis is: Is transfer of academic learning across educational settings for four learning disabled, elementary school-age children best explained by (a) external environmental factors, (b) internal cognitive processes, or (c) a combination of internal and external factors?

CHAPTER 2

LITERATURE REVIEW

The following four questions serve to organize this review of the literature on transfer of learning: What is meant by transfer of learning? How is it explained theoretically? Why has it become an issue in special education? What factors promote the transfer of learning?

Types of Transfer

To provide an answer to the first question posed above requires an examination of the many distinctions that have been made to identify different types of transfer.

Transfer of learning has been dichotomized along the following lines: (a) positive and negative, (b) vertical and lateral, (c) specific and nonspecific, (d) near and far, (e) literal and figural, (f) proactive and retroactive, and (g) as training and learning.

Other writers (Ellis, 1965; Gage & Berliner, 1979; Royer, 1979; Travers, 1982) have each delineated some, but never all, of these different types of transfer. The following synopsis includes definitions and

clarifying illustrations.

Positive and Negative Transfer

Positive transfer occurs when previous learning facilitates new learning (Gage & Berliner, 1979). We can anticipate, for example, that anyone who has learned to drive a car will readily transfer their driving skills to the task of learning to drive a small truck. Similarly, there is little doubt that for most students previous learning in subtraction and multiplication is positively transferred to the task of learning long division.

Negative transfer occurs when previous learning hinders new learning (Gage & Berliner, 1979). Anyone who plays racquet sports is familiar with this phenomenon, for they will have discovered that the tennis swing that they perfect in the summer has a deleterious affect on their squash game in the winter. Teachers become equally familiar with negative transfer when they discover that the phonics skills they have been teaching in English are inhibiting their students' learning of French pronunciation.

Vertical and Lateral Transfer

Vertical transfer occurs when new learning is

"acquired more rapidly when it has been preceded by previous learning of subordinate capabilities" (Gagné, 1970, p.335). For example, learning how to swim proceeds more rapidly once students have learned how to move their arms, kick their feet, put their faces in the water, and breath by moving their heads to the side. Knowing how to move the arms, feet, and head are subordinate capabilities which facilitate the more rapid acquisition of the new skill of swimming. The previous example of how prior learning in subtraction and multiplication is positively transferred to the learning of long division is also an example of vertical transfer. Subtraction and multiplication are subordinate capabilities which, when vertically transferred to the superordinate task of long division, will facilitate the more rapid acquisition of that skill.

Lateral transfer occurs when what has been previously learned spreads over a broad set of applications at "roughly the same level of complexity" (Gagné, 1970, p.335). All of us rely on lateral transfer in our daily lives. For example, once we have used a screwdriver to tighten a screw we are reasonably confident that we can use a different type

of screwdriver to tighten a different type of screw in another situation. Royer (1979) gives an example relevant to academic education. He describes a child who recognizes that the fractions he is learning about in school can be applied to the problem of deciding how to divide up a prized, but jointly owned, marble collection.

Specific and Nonspecific Transfer

Specific transfer refers to "a situation where there is a clear similarity between the stimulus elements in original learning and the stimulus elements in transfer learning" (Royer, 1979, p.54). From this perspective the example already given involving the transfer of learning from driving a car to driving a small truck is an instance of specific, as well as of positive transfer, since the stimulus elements in the two vehicles are similar. In schools, teachers often direct their students to attend to the similar stimulus elements in two words to uncover their meanings. For example, the words "transatlantic" and "transpacific" have the same prefix and similar root words in that both root words are the names of oceans. A student who knew the meaning of "transatlantic" and subsequently deduced the meaning

of "transpacific" would be exhibiting an instance of specific transfer.

Nonspecific transfer "differs from specific transfer in that there are no obvious shared stimulus elements in the originally learned task and the transfer task" (Royer, 1979, p.55). The marble collection example given to clarify the meaning of lateral transfer also applies to nonspecific transfer since the fraction problem taught in school and the marble collection do not share any obvious stimulus elements. Science teachers rely on nonspecific transfer when they expect students to apply the scientific method to experimental tasks that do not share common features.

Near and Far Transfer

Near transfer refers to a situation in which the setting for the original learning event and the setting for the event to which the original learning is transferred share very similar features. An example is learning how to play rugby and football on the same playing field. It is not the shared features of the two tasks but rather the almost identical settings that are presumed to mediate the transfer of learning

from one sport to the other. For example, a player's determination to win might transfer from rugby to football on the playing field but not be in evidence on the sand lot. Academically, near transfer often refers to the transfer of a skill or bit of knowledge from one school-learning-event to another school-learning-event (Royer, 1979). The transfer of arithmetic skills from a math class task to a science class task involving similar calculations is an example.

Far transfer refers to a situation in which the setting for the original learning event and the setting for the event to which original learning is transferred do not share similar features. The transfer of typing skills from the classroom to the office is an example of far transfer. Similarly, the little boy who used his school learning about fractions to divide his marble collection outside of school exhibited an instance of far transfer.

Literal and Figural Transfer

Literal transfer involves "the transfer of an intact skill or bit of knowledge to a new learning task" (Royer, 1979). The examples given previously to illustrate vertical and specific transfer also

serve to exemplify literal transfer.

Figural transfer "involves the use of some segment of our world knowledge as a tool for thinking about, or learning about, a particular problem or issue" (Royer, 1979). When a novice skier is told to stop by doing the same thing he would do were he skating, he is being encouraged to apply his knowledge about skating to solve the problem about how to stop on skis. When a student is told that the eye works like a camera, a process of figural transfer is being invoked by the teacher. The student's prior mechanical knowledge about the relationship between the lens, aperture, and film of the camera is used as a tool for learning about the physiological relationship between the cornea, pupil, and retina of the eye.

Proactive and Retroactive Transfer

Proactive transfer occurs when the effect of prior learning is to facilitate or hinder the recall of subsequent learning at a later transfer event (Reid, 1981; Travers, 1982).

Retroactive transfer occurs when subsequent learning facilitates or hinders the retention of previous learning and thereby affects the transfer of that previous learning to future learning events

(Reid, 1981; Travers, 1982).

It is the temporal sequence of the events within the positive or negative transfer processes which differentiates proactive from retroactive transfer. Positive proactive transfer, for example, takes place when previous learning about arm, foot, and head movements facilitates the recall and application of subsequent learning about swimming during a still later swimming examination. It also occurs when prior learning about English grammar facilitates the later application of learning about French grammar during a French composition exercise. Negative proactive transfer occurs when prior practice at tennis hinders the retention of subsequent learning at playing squash or when prior practice in English pronunciation hinders the succeeding retention of newly acquired French pronunciations.

An example of positive retroactive transfer is ~~X~~ when learning how to swim enhances students' retention of their previous learning about arm, leg, and head movements. As a result, subsequent applications of those three movements strengthen the learning of additional new swimming strokes. An academic example of positive retroactive transfer is when a student's learning of long division skills enhances his or her

retention of previous learning about multiplication and subtraction. Consequently, future applications of his or her multiplication or subtraction skills will be facilitated.

Negative retroactive transfer occurs when present practice at squash inhibits the retention of earlier learning about tennis and thereby frustrates the transfer of previously acquired tennis skills to future applications at the sport. Negative retroactive transfer also takes place when children learn the "ed" ending to indicate the past tense. It isn't uncommon for children to say "seed" when they previously knew to say "saw". Present learning about the past tense has, in such cases, inhibited the retention of their previous learning. As a result the transfer of that earlier learning to future applications is hindered.

Transfer of Training and Learning

The term "transfer of training" refers to research on transfer involving paired associate learning tasks, serial learning tasks, tasks involving physical manipulations, and other similar tasks (Royer, 1979; Travers, 1982). The defining characteristics of such research into transfer of training have been that the

transfer processes studied involved habits, behaviors, and rote memory tasks.

"Transfer of learning," on the other hand, has usually been associated with research and theorizing about concept formation and problem solving (Bruner, Goodnow & Austin, 1956; Gagné, 1964; Guilford, 1967; Harlow, 1949, Reese, 1968; Royer, 1979; Woodruff, 1964).

Previous educational research has tended to have been concerned with either the transfer of behaviors or the transfer of academic skills. It may be that some theoretical disagreements as to what variables influence the transfer process are rooted in a failure to clearly distinguish between these two types of transfer. This would be the case, for example, if the transfer of behavioral learning and academic learning are differentiable processes influenced by different factors.

The examples which have been used to illustrate the other types of transfer are, in each case, examples of these two types of transfer. They refer to either (a) a transfer process involving a behavioral task which easily becomes habitual, rote, or automatic such as driving a vehicle, playing a court or field

sport, swimming, using a screwdriver, typing or skiing; or (b) a transfer process involving a cognitive task such as arithmetic computation, language learning, using the scientific method, or learning through analogy.

Interrelationships

The examples used above to illustrate the distinctions previous writers have made between the different types of transfer serve to make an additional point. They make it obvious that the distinctions are neither mutually exclusive nor wholly synonymous. As a result of this fact it is difficult to provide a simple explanation of their interrelationships.

One possibility is to consider each distinction as a set of transfer instances and then to map the relationships between them in terms of inclusion, exclusion and intersection. Figure 1 is a model representing the interrelationships between these different types of transfer.

Insert Figure 1 about here

In the model literal and specific transfer are

Figure Caption

Figure 1. The transfer hexahedron.

Figure 1

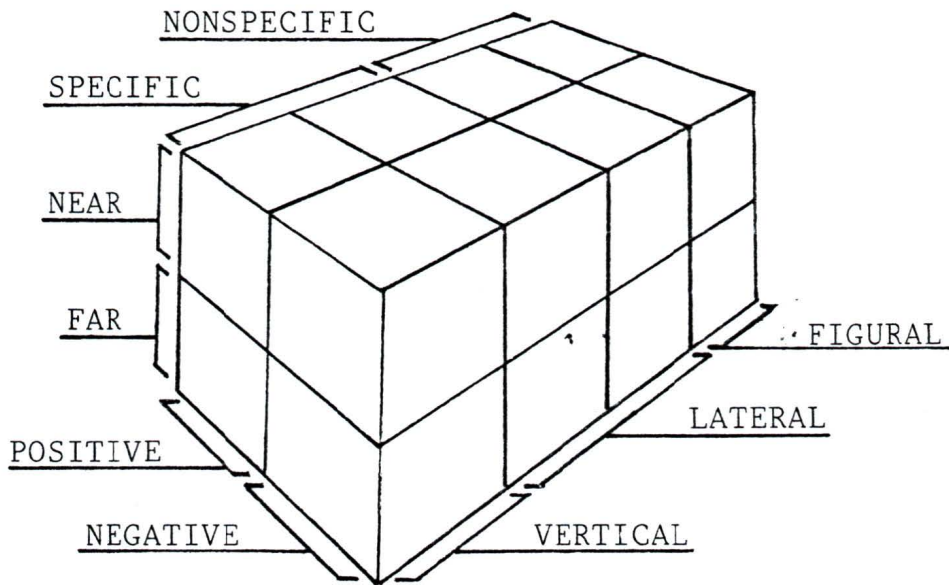

presumed to be synonymous. This requires a redefinition of specific transfer to include similar response patterns as well as similar stimulus elements.

Included within the set of specific transfer instances are the mutually exclusive subsets of vertical and lateral transfer. In addition, lateral transfer may also be non-specific as is depicted in the model. Figural transfer is viewed as another subset of nonspecific transfer. The distinctions made between near and far transfer settings can be applied to any of the transfer types already mapped. Similarly, positive and negative transfer can be applied to other types of transfer. All types of transfer can be considered as either transfer of training or transfer of learning depending upon whether behavior or cognitive learning is involved in the transfer process being considered. This model defines sixteen different types of transfer.

The use of the model to identify transfer processes is illustrated, below, by reconsidering some of the examples cited previously.

First, consider once again the example involving the transfer of training from driving a car to driving a small truck. We will assume that the settings for

the two driving events are not similar. The application of the model defines a positive, far, specific, lateral transfer of training process. In other words, prior training about car driving has facilitated later training about truck driving - tasks at roughly the same level of complexity, with similar stimulus elements and response patterns, but in different settings.

Second, recall the example involving the transfer of previous learning about subtraction and multiplication to the later learning of long division skills. This is an example of positive, near, specific, vertical transfer, assuming all learning occurred in the same class setting.

Third, reconsider the analogy involving the eye and the camera. This is an example of positive, far, nonspecific, figural transfer, assuming that the original learning about the camera took place in a different setting than the instruction about the physiology of the eye.

Fourth, consider once again the example cited to illustrate negative transfer. In that example prior learning about phonics in English class inhibited later

learning of pronunciations in French class. This is an example of negative near, specific, lateral transfer of learning.

This model can also be placed within the context of proactive and retroactive transfer processes. As a last example, remember the children who, having learned some verbs with an irregular past tense form (such as saw), later learned to form the past tense of all regular verbs with the "ed" ending. By over-generalizing some children mistakenly began to say "seed." They subsequently had difficulty learning the past tense forms of new irregular verbs. The model describes this as retroactive negative, far, nonspecific, lateral transfer of learning; assuming that both home and school settings were involved.

Summary

The foregoing synthesis of the different types of transfer distinguished by previous writers allows a much more explicit description of the transfer process than was previously possible. Additionally, by placing the different types of transfer into a coherent model it is possible to begin to see some of the parameters of the transfer process more clearly.

Namely: (a) power (degree of positive or negative transfer), (b) contextual semblance (near or far transfer), (c) task semblance (specific or nonspecific transfer), (d) level of abstraction (literal or figural transfer), (e) level of complexity (lateral or vertical transfer), (f) level of consciousness (transfer of training or learning), and (g) temporal sequence (proactive or retroactive transfer). These parameters, as they apply to issues in experimental research, will be discussed in the fifth chapter of this thesis.

Theories of Transfer

The second question to be addressed is how transfer is explained theoretically. As suggested earlier, the aforementioned distinctions between the different types of transfer emerged from two broad traditions of theoretical development and educational application. There were three basic positions. In behaviorism transfer is explained by means of the theory of identical elements. Two explanations have emerged from cognitive theory: (a) the cognitive construct theory of transfer, and (b) the information processing theory of transfer. Each explanation of transfer is discussed in turn.

The Theory of Identical Elements

The theory of identical elements has evolved within the behavioristic tradition and emphasizes an environmental perspective. The critical element of the transfer process is thought to be the features shared between the original learning event and the event to which that original learning is transferred. Its educational application involves behavior modification relating to the environmental features presumed to mediate transfer.

Thorndike and Woodworth (1901) suggested that the transfer of learning from one task to another would only occur when the two tasks shared similar stimulus elements. They also proposed that the amount of transfer between the two tasks would vary directly with the proportion of shared stimulus elements.

Later, Osgood (1949) included the principle of stimulus generalization in a conceptualization of the transfer process. Stimulus generalization, with respect to the transfer of learning, occurs when a pattern of responses associated with a given set of stimuli at the original learning event is emitted in the presence of a similar but different set of stimuli at the event to which the original learning is transferred.

S₁
S₂
S₃ } R

Osgood explained transfer in terms of a "transfer surface" - a three dimensional model of the transfer process. He hypothesized two interrelated factors: (a) that positive and negative transfer are functionally related to the similarities and differences between the stimuli and responses in the original learning and transfer tasks, and (b) that the amount of transfer between the two tasks would vary directly with the degree of similarity between the stimuli.

An extension to the theory is provided by Harris and Handleman (1980). They suggest that behaviors never directly trained or modeled may vary with trained or modeled responses, evidencing response generalization. An instance of response generalization occurs when skills learned at washing dishes are transferred to car washing or when accounting skills learned at school transfer to personal money handling outside of school. It is the similarities of the response patterns, rather than the stimulus elements, that are presumed to mediate transfer in these instances.

Limitations of the theory of identical elements. Proponents of the identical elements theory and its variations predict transfer only in situations where

there are identical or similar stimulus elements or response patterns.

Four types of transfer identified by the model (see Figure 1) are not explained by this theory. They are: (a) positive, far, nonspecific, figural transfer, (b) negative, far, nonspecific, figural transfer, (c) positive, far, nonspecific, lateral transfer, and (d) negative, far, nonspecific, lateral transfer. These types describe transfer processes in which neither the tasks nor the settings share similar stimulus elements or response patterns.

The explanation of retroactive and proactive transfer processes poses special problems for the theory of identical elements. It is not similarities or differences between original learning and the transfer events that affect transfer. In the case of proactive transfer there is a preceding learning event which facilitates or hinders a later transfer process. In the case of retroactive transfer there is an intervening learning event which either facilitates or hinders the transfer of prior learning to a subsequent application. As a result, the theory fails to provide an adequate explanation for all the types of transfer identified by the model when they

are placed within the temporal sequence of either a proactive or retroactive transfer process.

The exponents of the identical elements theory of transfer have been concerned, almost exclusively, with the transfer of habits and behaviors. This inadequacy is made clear by the following example. When a science teacher relies on students' prior mechanical knowledge about cameras to facilitate new learning about the physiology of the eye, there are no obvious stimulus elements or response patterns to explain this instance of positive, far, nonspecific, figural transfer. The similarity exists in the patterns of interrelationship between the stimulus elements that constitute the eye and camera. The relationship between the lens, aperture, and film of the camera is similar to the relationship between the cornea, pupil, and retina of the eye. Cognition of the patterns of interrelationship between the stimulus elements, rather than similarities between the stimulus elements themselves, appears to mediate transfer. There are many other patterns of interrelationship which appear to mediate transfer of learning. Many such patterns are prominent in education.

They include: (a) the rules of phonics, spelling, and grammar, (b) computational algorithms, (c) scientific laws and formulae, (d) artistic, musical, or other types of skill procedures, and (e) problem solving strategies.

The identical elements theory has developed within the behavioristic tradition. Its exponents have been concerned with the transfer of behaviors rather than cognitions. Its predictive power, explanatory value, and educational applications may be limited to the transfer of behaviors.

In summary, the identical elements theory is limited in two important respects; it does not account for all of the types of transfer, which have been distinguished and it provides no explanation for the transfer of cognitions independent of similar stimulus or response contexts.

The Cognitive Construct Theory

The internal mental processes that occasion and are presumed to mediate transfer of learning are emphasized by proponents of the cognitive construct theory of transfer. The critical element of the transfer process is thought to be the activation of a previously learned cognitive structure, associated with the original learning event,

that mediates the transfer of the original learning at a new event. This theory has developed within the context of cognitive learning theory and its educational application involves the use of cognitive training to promote the individual's acquisition and use of the cognitive structures which are presumed to mediate transfer of learning.

Tolman's protege Mcfarlane (1930) provided early experimental evidence of the cognitive mediation of transfer. He demonstrated that rats trained to swim, by the shortest route, to the goal box of a water filled maze were able to transfer their training to running to the goal box of the same maze when it was dry. Since the stimulus elements of the wet and dry conditions of the maze and the behavioral response patterns involved in running and swimming are not similar, Tolman (1932) suggested that the rats had formed a "cognitive map" of the maze which mediated the transfer of their training.

Harlow (1949) also provided evidence of the cognitive mediation of transfer. He conceptualized the transfer process in terms of the formation of "learning sets." He trained monkeys to solve a simple

discrimination problem. When the monkeys had mastered the first problem they were presented with similar problems to master, each requiring a different discrimination. After a long series of such problems the monkeys were able to solve new problems in the same class (in this case simple discriminations) with increasing speed and facility. Harlow said the monkeys, and in later experiments human subjects, had learned how to learn how to solve a kind of problem. "Learning sets" imply that previous learning about a set of problems can lead to the discovery of rules or procedures that facilitate later problem solving for problems of the same class. The relevant question is whether a rule has been learned or simply a pattern of responding. From the behavioristic perspective Harlow's "learning how to learn" is merely response generalization.

One line of investigation, by Kendler and Kendler (1962), supports Harlow's interpretation. They explored what happened when a rule was changed in midstream. One of their findings is of particular interest. They trained subjects within a class of problems as Harlow had done. They then reversed the rule for responding

while leaving the stimuli unchanged. According to Osgood this ought to have produced an instance of negative transfer. For older children and adults, it didn't; leading the Kendlers to hypothesize that a cognitive mediation of the transfer process supervened to allow positive transfer where the theory of identical elements predicted negative transfer. As a result of these and other experiments Travers (1982) proposes that the transfer of cognitions is mediated by the acquisition and later application of rules and problem solving strategies while the transfer of behaviors is explained by stimulus and response generalization.

Another modern cognitive theorist (Ausubel, 1968) has suggested that transfer is mediated by the learners possession of an abstract cognitive structure acquired during previous learning which acts as an advanced organizer for new learning at the transfer event. Ausubel's "advanced organizers" form an "ideational scaffolding" of abstract and generalizable cognitive structures into which new learning is supposedly integrated. Research evidence (Royer, 1979), however, suggests that learning proceeds from the concrete to the abstract posing a problem for Ausubel's

theory.

More recently, cognitive theorists have followed two lines of conceptualization for the cognitive structures presumed to mediate transfer. The first is an abstract structure made up of generic entries for frequently experienced events or concepts (Royer, 1979). These structures are hierarchical in nature with more specific information embedded at lower levels. As an example, a student would possess a structure for school. At the most general level such a structure would contain a variety of general information about schools - schools are places where children learn, teachers work there, etc. Embedded at levels below this would be more specific information in separate but related data structures. These might include information about individual classes, a weekly timetable, or a cognitive map of the school building, etc.

A second kind of structure has also been hypothesized. It consists of procedural information about how to solve a kind of problem. At the general level there might be a general approach strategy such as the scientific method and, at levels below this, particular procedures or strategies which might be

employed in problem solving.

Transfer occurs when new learning is channeled to relevant cognitive structures and previous learning is released and applied to the new learning task. It is presumed that both kinds of structures could be activated simultaneously at the transfer event providing both a data base and a set of procedures for operating on that data base from prior experience.

Limitations of the cognitive construct theory.

Cognitive construct theorists presume that intervening cognitive processes mediate the transfer of learning. Several important questions about these processes remained unanswered. How are hierarchical cognitive structures organized and differentiated? How are they activated at the transfer event? How are habits and behaviors differentiated from cognitions in the transfer of complex learning events? How can the hierarchical cognitive structures be characterized and represented for experimental purposes?

Many cognitive theorists have concentrated on demonstrating the inadequacies of the behavioristic explanations for the transfer of learning process. Unfortunately, they have avoided elucidating their own alternative explanation except in the most general

terms (Bower & Hilgard, 1981; Royer, 1979).

The Information Processing Theory of Transfer

The information processing theory of transfer emphasizes the processes through which original learning is represented in memory and later retrieved at the event to which learning is transferred. This theory has evolved within the context of the information processing theories of human learning and memory. Its educational applications involve enhancing memory storage and retrieval processes to promote transfer of learning.

An early conceptualization of recall and transfer was provided by Hoffding (1892). Hoffding supposed that an external stimulus (A) produced an internal sensory trace (a) which became associated with an internal representation of the response event (b), which in turn gave rise to the overt response (B). In a later situation, a new stimulus (A') comes to be associated with the old sensory trace (a), ultimately producing the same overt response (B). Hoffding presumed that the new stimulus (A') became connected to the old sensory trace (a) because of the shared features of the original stimulus (A) and the new

stimulus (A'). The transfer process as Hoffding conceived of it is charted in Formula 1. The capitals signify external events while the lower case letters represent internal cognitive events. While Hoffding's

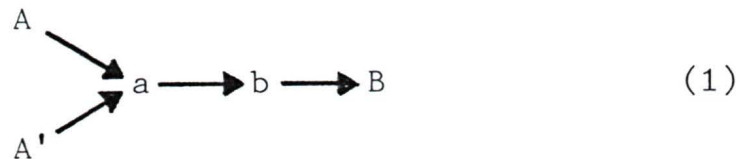

conceptualization introduced memory into the transfer process, it did not explain how external stimuli became encoded in memory as internal traces, how the internal traces became associated with internal response representations, or how those representations were later retrieved at the transfer event to produce overt responses. In addition, Hoffding's explanation does not predict transfer in any situations other than those already predicted by the theory of identical elements.

Modern theorists have borrowed from communications and computer technology to develop a model of the internal processes presumed to mediate learning and transfer. The information processing theory of human memory and learning has evolved using terminology and

concepts originally developed in three fields:

(a) communications information theory, (b) computer programming, and (c) robotology. These have been applied as analogues to human cognitive processes (Bower & Hilgard, 1981; Snelbecker, 1974).

Communications information theory developed methods for making quantitative measures of the information put into a communications system. This allowed the input to be compared to the information put out by the same system at the other end. Any interference in the communications effort could then be quantified and understood in terms of discrepancies between the input and output of information.

Information theory was of value to cognitive theorists as it provided a three step model of information communications (input-transmission-output), and a method for comparing the input and output components. However, as an analogue of human cognitive processes this conceptualization had a major weakness; the intermediate step still remained undefined. A major impact of information theory on learning theory was to concentrate attention on the need to more fully understand the intermediate step between input and output (Postman, 1964). Computer programming provided a useful way of characterizing this missing conceptual

link. A computer program is the complete set of instructions required for processing a given set of data (Snelbecker, 1974). Since computer programs can be self-modifying; that is, able to change or develop new instructions based on an analysis of the input data, some theorists have argued that computer programs are analogues of human cognitive processes (Simon & Newell, 1971). A strength of this approach is that the detailed and precise manner in which computer programs must be written lends a rigorous formal structure to the characterization of a cognitive process. In addition, a hypothetical step-by-step definition of a cognitive process can be written in a parallel format as a computer program and used to predict human performance. This provides an external test of validity for the theoretical conceptualization of the cognitive process hypothesized.

The contribution of robotology, and by extension the science of artificial intelligence, has been twofold. Firstly, the concept of functional parallelism provides a rationale for the use of analogous simulations: the use of computer programs to simulate human cognitive processes. Functional parallelism occurs when there is a point-to-point correspondence between the critical features of two systems in terms of the functions the systems carry out. While the systems may be as physically different as the computer and the human brain, they are presumed to be different

realizations of the same theory if they are functionally parallel. This assumption of theoretical equivalence underlies the use of computer programs as simulations of human cognitive processes.

Secondly, the functions carried out by a system are presumed to be organized in a hierarchical format composed of subroutines which constitute the system's program. This conceptualization bridges the gap between function (realized in the robot or human as behavior) and program (realized in the robot's artificial intelligence as the computer program and in humans as the cognitive process) at a theoretical level.

From the perspective of information processing theory the relevant processing program for transfer of learning is the storage of information at the original learning event and its retrieval at the event to which the original learning is transferred. Such a program involves the integration of the original learning into an existing structure of subroutines located in long term memory, together with a procedural subroutine for its retrieval at the transfer learning event (Royer, 1979). From this perspective transfer of learning depends upon the likelihood of retrieving original learning at the transfer learning event rather than any overt similarities between the two events. Any subroutine which activates retrieval

would promote transfer. The identical elements theory is subsumed in this explanation as merely a set of subroutines that can be critical to the transfer process. For example, the identification of similar stimulus elements between two learning events to promote transfer is one possible subroutine.

Other possible subroutines critical to the transfer process and consistent with the cognitive approach to transfer include (a) mnemonic strategies such as active rehearsal or categorical clustering, (b) general problem solving strategies such as deductive logic or the scientific method, and (c) specific problem solving strategies such as spelling rules or arithmetic algorithms.

The information processing theory of transfer answers some of the questions which arose in connection with the cognitive construct theory. Most importantly, it provides a methodology for the explicit representation of the cognitive processes presumed to mediate transfer for experimental purposes.

Limitations of the information processing theory.

A limitation of this theory of transfer is that affective factors, while no longer ignored conceptually by information processing theorists, have not yet been fully considered in the context of the transfer process.

This shortcoming has serious implications for the theory. Firstly, affective factors have been shown to be critical elements in the transfer process (Marholin & Siegel, 1978; Winnett, 1970). Secondly, the introduction of affective factors into the information processing theory of the transfer of learning will extend the definition and explanation of the transfer process to new areas.

Neisser (1963) levels another criticism at information processing theory. He argues that computer programming capabilities and human cognitive processing capabilities are not functionally parallel in important ways. For example, he notes that computer and human memories are quite different. Computers do not forget while humans are noted for this foible. Computers also process information at much higher speeds than people. Additionally, the computer remembers by comparing input data to previously stored data in accordance with a programmed search strategy. Stored data is organized in list structures and the search strategies are also coded as list structures. The important aspect of information processing theory with respect to transfer of learning is the memory search process that leads to the retrieval of relevant information at the transfer event. There is considerable controversy over how to best characterize retrieval. Three suggestions that have been made define retrieval in terms of a serial

search, a parallel search, and a heuristic search.

In a serial search a stimulus item is compared to all memory locations (individual items in a list structure) one at a time. In a parallel search all memory locations are compared to the stimulus item simultaneously. In a heuristic search the stimulus item is compared to a selection of memory locations in a limited but directed search strategy.

The above discussion raises several questions: Is human memory composed of list structures? Do human retrieval processes parallel those possible to construct using computer programming simulations? Do different types of retrieval correspond to different types of transfer?

As the above questions make clear, there are as many questions as answers provided by the information processing theory of the transfer of learning. The theory does have the advantages, though, of accounting for a far wider range of transfer events than the identical elements theory and of being far more precise and detailed than the cognitive construct theory.

Summary

A number of inferences can be drawn from the foregoing sections of this chapter.

Firstly, the transfer of learning is not a singular process. The transfer hexahedron provides a model of the interrelationships between the different types of transfer suggested by previous writers. However, two immediate problems remain. Each set of transfer instances identified by the model needs to be succinctly defined. Two factors need to be taken into account in the definitions. They must ensure that: (a) all the sets sum to equal an exhaustive account of the transfer process, and (b) the sets are mutually exclusive. In addition, the definitions must allow for each type of transfer to be operationally defined and therefore open to experimental investigation.

Secondly, the theory of identical elements may be a necessary, but is most certainly not a sufficient, explanation of the transfer process. More than the degree of similarity between the stimulus elements and response patterns at the original learning and transfer events is involved in a full explanation of the transfer process. The very fact that a variety of different types of transfer exist, involving the transfer of both behaviors and cognitions, suggests

that there are a variety of factors involved in the mediation of the transfer of learning.

Thirdly, different sets of factors, or a different distribution of emphasis across a constant set of factors, may be involved in the mediation of each of the different types of transfer of learning. A possible goal of future educational research is the quantitative description of the parameters (identified previously in connection with the transfer hexahedron, Figure 1) of the transfer process under varying conditions reflecting the factors presumed to mediate the transfer of academic learning.

The issues involved in understanding the transfer of learning are both complicated and extensive. Royer (1979) notes that research into transfer of learning, especially recently, has been neglected. It may be that the confusion and abstruseness surrounding the various descriptions of the transfer process have been partially responsible for this fact.

Transfer and Special Education

The third question to be addressed is why transfer of learning has become an issue in special education. In order to answer this question it is necessary to (a) characterize contemporary special education settings,

(b) discuss the placement of children within those settings, and (c) to characterize learning disabled children.

Special Education Settings

Hammill, Bartel and Bunch (1982) have enumerated the settings in which special education occurs.

1. The special school.
2. The special class.
3. The resource room.
4. The regular classroom.

These settings can be classified by the degree to which they segregate children from the regular school environment.

The special school provides an educational setting in which the participating children are completely segregated from their peers and the regular school premises.

The special class isolates the children from their peers during all aspects of their education except the non-instructional components.

The resource room provides special education services to the children during portions of their school day but the children remain based in their regular classrooms.

The regular classroom can be the location of a special education program when it is feasible for the classroom teacher to implement the program or when supplementary inclass aids or services are available. The participating children remain wholly based in their regular classroom

but components of their instructional programs differ from those of their peers.

Placement of Children

Since 1975, the placement of children in these special education settings has been guided, in the U.S.A., by the Education of All Handicapped Children Act (Public Law 94-142). In Canada, documents such as Standards for educators of exceptional children in Canada (Hardy et al., 1971) and the 1970 report of the Commission on Emotional and Learning Disorders in Children (Roberts & Lazure, 1970) have set a similar tone for the placement of children in special education settings. Several provinces have enacted mandatory legislation governing student placement (Hammill, Bartel & Bunch, 1984):

Public Law 94-142 has several important implications for the educational placement of a handicapped child. These implications parallel those which may be drawn from the legal statutes of those Canadian provinces with mandatory legislation. Firstly, Public Law 94-142 prescribes the child's placement in the least segregated setting. Secondly, it anticipates the child's continued partial participation in the regular classroom setting. Thirdly, the resource room, rather than the special class or special school, is the option of first choice outside the regular classroom. Fourthly, it prescribes a regular

review of the child's placement with respect to his or her participation in the regular classroom program.

These factors establish two implicit end goals for the delivery of special education services. The first is integration; the goal of enabling the handicapped student to remain in, return to, or eventually enter the regular classroom setting. The second is normalization; the goal of enabling the handicapped student to remain in, return to, or eventually enter the normal instructional program. While not every student receiving a special education will be able to meet these goals, the mandate for integration and normalization contained in Public Law 94-142 highlights the need to consider the transfer of learning from special education settings to regular classrooms as a major objective in the education of handicapped children. While not mandated in federal law, the goals of integration and normalization have also been consistently maintained in Canada (Hardy et al., 1971).

In this context, transfer of learning refers to both transfer between special education and regular classroom settings and transfer between the special and normal instructional components of the student's individual education program. In general, depending upon the student's program, transfer of learning might refer to one of three possibilities: (a) from a special program in the regular

classroom to a normal program in the regular classroom, (b) from a special program outside the regular classroom to a special program in the regular classroom, or (c) transfer from a special education program outside the regular classroom to a normal program in the regular classroom.

The focus of this thesis proposal is on the third possibility above; the transfer of learning originally acquired in a special education program occurring outside the regular classroom to applications within a normal instructional program occurring in the regular classroom. The target population is made up of learning disabled elementary school children whose individual education programs divide their school days between special education programs occurring outside the regular classroom setting and normal school programs occurring within regular classroom settings.

Learning Disabled Children

The Canadian Association for Children and Adults with Learning Disabilities (Definition of Learning Disabilities, 1981), has approved the following definition of learning disabilities:

Learning disabilities is a generic term that refers to a heterogeneous group of disorders due to identifiable or inferred central nervous system

dysfunction. Such disorders may be manifested by delays in early development and/or difficulties in any of the following areas: attention, memory, reasoning, coordination, communicating, reading, writing, spelling, calculation, social competence, and emotional maturation.

Learning disabilities are intrinsic to the individual and may affect learning and behavior in any individual, including those with potentially average, average, or above average intelligence.

Learning disabilities are not due primarily to visual, hearing, or motor handicaps; to mental retardation, emotional disturbance, or environmental disadvantage; although they may occur concurrently with any of these. Learning disabilities may arise from genetic variations, biochemical factors, events in the pre- to peri-natal period, or any other subsequent events resulting in neurological impairment. (p. 1).

Public Law 94-142 mandates that all handicapped children receive a specially designed instructional program to meet their unique needs. Included within the definition of all handicapped children are those children with specific learning disabilities. The Act provides a definition of children with specific learning disabilities which reads as follows (Hammill et al., 1981):

The term "children with specific learning disabilities" means those children who have a disorder in one or more of the basic psychological processes involved in understanding or in using language, spoken or written, which disorder may manifest itself in imperfect ability to listen, think, speak, read, write, spell, or do mathematical calculations. Such disorders include such conditions as perceptual handicaps, brain injury, minimal brain dysfunction, dyslexia, and developmental aphasia. Such term does not include children who have learning problems which are primarily the result of visual, hearing, or motor handicaps, of mental retardation, of emotional disturbance, or environmental, cultural, or economic disadvantage. (p. 337).

Controversy and confusion have surrounded the process of defining the term "learning disabilities" (Forness & Cantwell, 1982; Keogh, 1983; McLeod, 1983; Tucker et al., 1983). Child characteristics such as (a) developmental immaturity (Ames, 1983), (b) academic underachievement (Lloyd et al., 1980; McLeod, 1983; Ysseldyke et al., 1982), and (c) behavioral, emotional, physical, or mental handicapping conditions (Hammill et al., 1981; Lloyd et al., 1980; Mann et al., 1983; Ysseldyke et al., 1982) have

produced symptomologies and psychometric test results indistinguishable from those of learning disabled children. As well, these characteristics may be concomitant with the presence of a learning disability in some children, further confusing identification.

These perspectives have spawned controversies over the viability of a comprehensive definition and have led to the development of competing definitions grounded in different views as to what is the best basis for identification. For example, the following have been suggested as bases for the identification of learning disabled children:

1. Empirical evidence of a neurological or cognitive dysfunction (Cruickshank, 1983; Myklebust, 1983).
2. Measured discrepancies in educational performance between the subject and individuals of the same age and ability level (McLeod, 1983).
3. Measured deficiencies in processing abilities such as those related to perceptual mode, memory, sequencing, or closure (Hammill et al., 1981).

Other problems further complicate the issues of definition and identification. Some writers (Gillespie & Sitko, 1974; Ysseldyke et al., 1983) suggest that most tests used in psycho-educational decision-making are technically inadequate to the task of identifying learning disabled children. Further, research evidence indicates that factors other than formal test results are

prominent in the identification and placement of children termed "learning disabled". These factors include:

1. The preconceptions, about the child, of the professionals responsible for assessment and placement (Foster et al., 1978).
2. The practice of labeling the child disabled solely on the basis of a perceived need to gain his or her admission to special education services (Kirk & Kirk, 1983; Ysseldyke et al., 1982).
3. Child characteristics such as physical appearance, sex, or socio-economic status (Ysseldyke et al., 1983).
4. External constraints such as the reason for the original referral, parental preferences, and available services (Ysseldyke et al., 1983).

In the face of these difficulties it has been suggested that researchers (a) use "learning disabled" as a generic term referring to a heterogenous population of mildly handicapped individuals (Keogh, 1983; Lloyd et al., 1980), (b) use specific marker variables to identify the characteristics of individual children or the homogenous subpopulations to which they belong (Lloyd et al., 1980; Mann et al., 1983), and (c) report the descriptive statistics used to define research samples (Torgensen & Dice, 1980). This is the approach which is adopted in this thesis. Using such marker variables facilitates valid comparisons

between research findings, limits generalizations to the subpopulations actually sampled, and assists in the identification and differentiation of the subpopulations that make up the overall population of learning disabled individuals.

The marker variable approach is consistent with other efforts to characterize learning disabled children. These efforts have been plentiful and diverse. It is beyond the scope of this thesis proposal to discuss all of the characteristics that have been related to the performances of learning disabled children. It is sufficient to say that research efforts have focused attention on three main areas which have a bearing on the issue of transfer of learning:

1. Maladaptive behaviors (Bryan, 1978; Bryan et al., 1982; Forness & Esveldt, 1975; Lloyd et al., 1980; McKinney & Feagans, 1983; Richey & McKinney, 1978; Zeitlin, 1982).

2. The deficient use of cognitive strategies (Arbitman-Smith & Haywood, 1980; Cruickshank, 1977; Feuerstein et al., 1979; Lloyd et al., 1980; Lloyd, 1980; Meichenbaum, 1980; Morna, 1976).

3. Information processing dysfunctions (Ayers, 1972; Cruickshank, 1983; Feuerstein et al., 1979; Kirk & Bateman, 1962; Ottenbacher, 1982; Royer, 1979).

The characterization of learning disabled children as exhibiting maladaptive behaviors has generally occurred

within the context of a behavioristic approach to their performances. From this viewpoint transfer of learning has been interpreted as the remedial training of adaptive behaviors in one learning situation and their later transfer to other learning situations. The factors influencing the transfer of adaptive behaviors have been understood within the context of the theory of identical elements. Recommendations for instructional programming to promote transfer have been based on the use of behavior modification techniques to maximize stimulus and response generalization.

The characterization of learning disabled childrens' performances as evidencing a deficient use of cognitive strategies has occurred within the framework of cognitive learning theory. From this perspective transfer of learning has been understood in terms of the cognitive construct theory of transfer in which transfer of learning is mediated by rules, procedures, and problem solving strategies which activate the application of previous learning at the transfer event. Recommendations for instructional programming have been based on the use of cognitive training techniques to train students to acquire and effectively use cognitive strategies which promote the transfer of learning.

The characterization of learning disabled students' performances as information processing dysfunctions

has taken place within the context of the information processing theory of human memory and learning. The information processing theory of transfer of learning explains transfer as the retrieval from memory of prior relevant learning, and its application at the transfer event. Recommendations for instructional programming have been based on the use of mnemonic and other strategies to enhance the probability of retrieval.

It is not intended that the preceding paragraphs should leave the impression that there is no common ground, in research, theory, and application, between the three lines of development described. This is, in fact, far from the case. Much of the applied research, concerned with the promotion of positive transfer for handicapped populations, has been eclectic in the sense that methods derived from more than one theoretical tradition have been combined in practice.

Promotion of Transfer

The fourth question to be addressed is what factors promote transfer of learning. Several different methods to promote the transfer of learning have been tested experimentally. The contexts of these applied research efforts have been very different in several respects.

Firstly, experimental samples have ranged across a wide spectrum of handicapped populations representing a

variety of handicapping conditions including behavioral, mental, and emotional handicaps as well as learning disabilities.

Secondly, the experimental samples have been drawn from a range of age groupings.

Thirdly, transfer has been studied in and between a wide variety of settings including laboratory and clinical settings as well as educational settings.

Fourthly, some studies have been concerned with the transfer of behaviors while others have been concerned with the transfer of academic skills.

Fifthly, different studies have involved different types of transfer.

All of these considerations mitigate against (a) valid comparisons between research findings, and (b) the generalization of research findings to applications involving learning disabled elementary school children.

With these cautions in mind, a discussion of the experimental research concerned with the promotion of transfer of learning cannot be expected to result in any definite conclusions. It can, however, aid in formulating reasonable research questions.

Two general approaches to the promotion of transfer of learning have been developed for handicapped populations. The first involves the use of behavior modification

techniques and the second involves cognitive training.

Behavioristic Methods

The technology of educational behavior modification has been applied more extensively to the elimination of maladaptive behaviors or the establishment of adaptive behaviors in the classroom than to the direct promotion of academic learning or transfer (Winett & Winkler, 1972).

Some researchers have made probes to determine if their target behaviors were occurring at near (O'Leary et al., 1969), far (Wahler, 1969, Andersen & Redd, 1980), or lateral (Conway & Bucher, 1976) transfer events. Such probes have frequently indicated that while classroom behavior modification programs for students receiving a special education have been successful in bringing about situation-specific or domain-specific effects; they have failed to provide behavioral changes which were (a) durable, (Turkewitz et al., 1975; Keogh & Glover, 1980), or (b) transferred to other settings (Wahler, 1969; Andersen & Redd, 1980), or (c) transferred to other times of the day (O'Leary et al., 1969, Marholin & Siegel, 1978), or (d) transferred to very similar activities in the presence of other teachers in the same setting (Andersen & Redd, 1980).

These research findings have led several researchers to conclude that for some handicapped students transfer

of learning is not a gratuitous or automatic occurrence even when a behavior modification program has been successful in bringing about situation-specific behavioral changes (Baer & Wolf, 1970; Kanfer, 1971; Keogh & Glover, 1980; Koegel & Rincover, 1977; Stokes & Baer, 1977). This, in turn, has led to widespread support for the notion that, for special education students, programming to maximize the transfer of learning is necessary (Baer et al., 1968; Bandura, 1969; Conway & Bucher, 1976; Marholin & Siegel, 1978).

From the behavioristic perspective there is an explanation why transfer does not occur automatically. The behavioristic interpretation of learning is that student behaviors are patterns of responses associated by reinforcement with discriminated stimuli at a learning event. When either the stimulus setting or reinforcement contingencies are changed behavioral responding also changes. Transfer may fail to occur when (a) the discriminated stimuli with which responding has become associated at the original learning event are not present at the transfer learning event, or (b) when the reinforcement contingencies for responding at the original learning event and the transfer event are dissimilar.

Behavior modification programs for special education students have tended to provide highly discriminable

stimulus contexts and highly explicit and systematic schedules of reinforcement (Keogh & Glover, 1980). While this approach generally strengthens the behavior modification program it may do so at the expense of any generalization effects (Karlovy, 1980; Keogh & Glover, 1980).

Behavioral strategies for maximizing transfer of learning have been primarily concerned with overcoming this limitation by:

1. Providing discriminative stimuli at the original learning and transfer event.
2. Making the stimulus contexts at the original learning and transfer events similar.
3. Making the reinforcement contingencies at the original learning and transfer events similar.
4. Programming original learning in a variety of stimulus contexts.
5. Programming a breadth of responses at the original learning event.
6. Providing an indeterminable or delayed schedule of reinforcement at the original learning event.

All of these methods involve applications of the theory of identical elements or the use of principles derived from operant conditioning to promote transfer. The first three methods emphasize the provision of similar stimulus elements or reinforcement contingencies at the original

learning and transfer events. The latter three methods involve the promotion of either stimulus or response generalization, or the manipulation of reinforcement contingencies, in accordance with principles derived from operant conditioning, at the original learning event. In every case it is (a) external features of the learning environment, rather than internal cognitive processes, that are presumed to mediate transfer, and (b) behavioral changes, rather than changes in cognitive processes, that are the objectives of the method.

Discriminative stimuli. A discriminative stimulus is one with which reinforcement becomes associated at the original learning event.

The discriminative stimulus selected for association with reinforcement at the original learning event must have a high probability of occurring persistently at the events to which original learning is intended to be transferred. If this is not the case, then the original learning may remain specific to the situation in which it occurred.

Marholin and Siegel (1978) provide an example of this method. A speech therapist, fearful he was becoming the sole discriminative stimulus for a young girl's speech training, invited the girl's mother to sit in on the girl's speech training sessions which took place in the

therapist's office. As a result, the mother became a discriminated stimulus for the girl's verbal behavior. When her speech training was completed the girl's new speech capabilities were transferred to the home setting. At home her new speech skills were transferred to her verbal interactions with other family members, initially only in her mother's presence, but later on all occasions.

A discriminative stimulus need not be a person. Task specific instructions and modeling have been successfully employed to promote transfer between special education and regular classroom settings (Marholin et al., 1976; Schumaker et al., 1982). An example is the "Multipass" system for improving reading comprehension (Schumaker et al., 1982). The "Multipass" system utilizes behavior modification techniques to teach a strategy to improve reading comprehension for learning disabled students. Since the strategy also involves cognitive aspects it will be considered along with other cognitive training applications in a later section.

Similar stimulus contexts. The provision of similar stimulus contexts at the original learning event and at the event to which original learning is intended to be transferred has been approached in two ways. Several researchers have recommended establishing a special

education setting for original learning which closely resembles the setting to which the original learning is intended to be transferred (Andersen & Redd, 1980; Bandura, 1969; Conway & Bucher, 1976; Rose et al., 1982; Walker & Buckley, 1972). This involves the matching of antecedent stimulus conditions such as class rules, curriculum materials, decor, instructional methods, class size, time of day, and significant persons with the stimulus conditions existent in the regular classroom. Walker and Buckley (1972), for example, used the same academic materials in a special education classroom as were used in the regular classroom to successfully promote the transfer of students' newly acquired learning back to the regular classroom.

Andersen and Redd (1980) emphasize the possibility of gradually altering instruction in the special education setting to resemble normal instruction in the regular classroom. This might involve the initial use of one-to-one or small group instruction, special materials, and cues and prompts to support original learning in the special education setting. This would be followed by the gradual introduction of large group instruction, normal program materials, and the fading of cues and prompts so that original learning comes to occur in a stimulus context similar to the stimulus context of the regular classroom program.

Another possibility is to alter the transfer setting to support behavioral changes initiated outside of it. The essential feature of this method is the alteration of the transfer setting to simulate the stimulus context of original learning. Stokes and Baer (1977) recommend the identification, prior to original learning, of the events and settings where transfer might be needed; and a post transfer documentation of the extent and limits of transfer. If transfer of original learning is absent at identified events or settings then the stimulus contexts of those settings or events would be systematically altered to resemble the stimulus context of original learning.

This method remains the preferred alternative for the promotion of transfer among behavioral technologists (Marholin et al., 1976). However, the prospect of expensive and time-consuming interventions in a wide variety of transfer settings or at a variety of transfer events has been a paramount motivation for researchers seeking alternative methods of promoting transfer (Baer & Wolf, 1970).

Matching reinforcement contingencies. A strategy of matching the reinforcement contingencies at original learning to previously identified stable and prevalent natural reinforcement contingencies that can be trusted

to operate in the transfer setting has been promoted by several writers (Bandura, 1969; Marholin & Siegel, 1978; Stokes & Baer, 1977). Behaviors which come to be maintained, during original learning, by social reinforcers such as affirming gestures, smiles, or eye contact; or which lead to intrinsically satisfying consequences such as peer acceptance, teacher appreciation or successful task completion are more likely to be maintained in transfer settings than behaviors dependent upon tangible reinforcers (Rose et al., 1982). This is because tangible reinforcement is not common in regular classroom settings or other non-therapeutic settings.

Baer and Wolf (1970) have noted that in some instances there may be effective reinforcement contingencies in the transfer setting to which the student can be introduced. Once entered, such reinforcement acts as a "behavior trap" which will shape and maintain an increasing repertoire of behaviors under the control of satisfying consequences or social reinforcement. They cite the example of a boy who was reticent to interact with the other children at his preschool. His peers were prompted, by the teacher, to interact with him and then both he and his peers were reinforced by the teacher during the interactions. Gradually, the teacher reinforcement was faded. The boy continued interacting with his peers, reinforced by his

enjoyment of shared activity. The programming, at original learning, of entry responses to a "behavior trap" in the transfer setting would inevitably engage the student in the application of previously learned skills in the new setting.

Another approach involves manipulating reinforcement contingencies in the transfer setting to match those in effect at original learning. This involves the introduction of a contingency manager into the transfer setting.

The role of the contingency manager is to continually shape all relevant behaviors and adjust reinforcement schedules until maintenance of the student's previously learned behavior stabilizes in the transfer setting. At this juncture prompts and cues are gradually faded and the reinforcement schedule is gradually thinned until contingency management becomes redundant. Marholin and Siegel (1978), for example, describe a primary school age boy who refused to speak outside his home except in the presence of a family member. His language development was normal for his age. He was removed from his regular class at school to a mental health center class where a token reinforcement program succeeded in increasing his verbalizations to a criterion level corresponding to the frequency of verbalization levels of the students in his regular school class. Upon his return to school the

contingencies of reinforcement (the token reinforcement program and teacher praise) were continued in the regular classroom. Over several weeks the reinforcement program was faded out. The boy's verbal behavior remained at criterion levels.

Parents, teachers, peers, and siblings have all proved to be effective contingency managers able to maintain a subject's original learning in the transfer setting (Nelson et al., 1973; Tharp & Wetzel, 1969; Walker & Buckley, 1972). Nelson et al. (1973) obtained results where adult contingency management was neither feasible nor desirable. From a group of behaviorally disordered peers some children were selected as subjects and others were trained to be their contingency managers. Both behavioral objectives and transfer to other group settings were realized. However, problems in maintaining the supportive behavior of the contingency managers have arisen in other studies (Conway & Bucher, 1976).

Sufficient exemplars. It has been suggested by a number of authors that the provision of a wide variety of examples and occasions to practice newly acquired responses prior to transfer should promote stimulus generalization (Atthowe, 1973; Gage & Berliner, 1979; Karoly, 1980). This involves varying features of the

stimulus context, such as the teacher, classroom setting, teaching methods, instructional materials, or times, while holding the lesson objectives and response criterion constant. For example, a retarded woman receiving speech therapy in a token economy did not transfer her new verbal skills to other settings until her therapy had occurred in more than one setting. After being taught in two stimulus settings she transferred her newly acquired verbal abilities to another setting where therapy had never occurred (Griffith & Craighead, 1972).

The programming of original learning in a variety of stimulus contexts is, in fact, a programmed simulation of the stimulus generalization process as it is understood from the perspective of the theory of identical elements.

Programming a breadth of responses. A similar approach involves promoting a variety of responses across the breadth of a response class while holding the stimulus context constant.

Conway and Bucher (1976) have suggested the documentation of behavioral changes that co-vary with trained responses. They hypothesize the existence of functionally related response classes and argue that programmed generalizations across the breadth of such response classes would promote transfer of learning.

The "Project Math" curriculum (Cawley et al., 1976)

exemplifies the application of both programmed stimulus and response generalizations to the teaching of mathematics to special education students at the elementary level. Cawley's program involves two parameters relevant to the promotion of transfer of learning. The first involves the teacher's provision of instruction in a variety of perceptual modes (sufficient exemplars) while holding the student's responses constant - in effect, programming stimulus generalization. The second involves the teacher eliciting student responses in a variety of modes (breadth of responses across a functionally related response class) while holding the instructional stimulus constant - in effect, programming response generalization.

The efficacy of Cawley's approach in promoting transfer of learning between educational settings has not yet been established experimentally. However, this approach is worthy of study as stimulus and response generalizations are pervasive characteristics of behavior reported in both animal and human research and have been linked to transfer in animal research (Stokes & Baer, 1977).

Indeterminable or delayed schedules of reinforcement.

An indeterminable reinforcement schedule is one for which it is impossible to discriminate reinforcement occasions from non-reinforcement occasions until afterwards (Stokes & Baer, 1977). There have been a number of reports

of increased durability for previously learned behaviors in a transfer setting when indeterminable schedules of reinforcement had been used to establish those behaviors in the pre-transfer setting (Koegel & Rincover, 1977; O'Leary et al., 1969; Wahler, 1969). It is likely indeterminable reinforcement schedules gain their strength by being more compatible with the reinforcement contingencies in the transfer setting than the high frequency schedules typical of therapy and special education instruction (Conway & Bucher, 1976; Premack & Anglin, 1973; Wahler, 1969).

Delay of reinforcement has also been used to promote the durability and transfer of learning (Schwartz & Hawkins, 1970). Schwartz & Hawkins used video tapes of in-class behavior viewed after school by the student, with reinforcement for desired behaviors delayed until the video tape viewing session. This was a more effective technique than direct instruction had been in bringing about behavioral change. Transfer of the desired behaviors to other classes occurred.

Summary: Behavioristic Methods

The identification of the crucial variables which promote the consistent and enduring transfer of learning for learning disabled elementary students still requires theoretical and applied research efforts. This conclusion

is based on the fact that only a very small number of studies have involved learning disabled elementary school children and that generalizations from other handicapped populations may not be valid. In addition, several of the studies involving handicapped subjects are single subject studies (for example: Marholin and Siegel, 1978; Baer and Wolf, 1970; Schwartz and Hawkins, 1970), without reversal, multiple baseline, or multiple probe designs, and are not convincing experimental demonstrations.

A review of research evidence undertaken by Marholin et al. (1976), from a behavioristic perspective, concludes that transfer of learning depends upon the stimulus conditions and reinforcement contingencies in the original learning and transfer settings. This seems an overly strong conclusion for two reasons. Firstly, the transfer of behaviors, but not necessarily cognitions, may depend on external environmental factors. There is insufficient evidence to generalize conclusions about the transfer of behaviors to all situations in which transfer of learning occurs, especially those involving the transfer of cognitions. Secondly, some types of transfer, most notably non-specific and literal transfer, are left unexplained by this conclusion. A more realistic approach might be to look for the ways in which behavior modification techniques and

cognitive processes might be working in tandem in the transfer process.

All of the methods enumerated in the above section rely upon the manipulation of factors external to and beyond the control of the individual whose learning we are attempting to transfer to diverse applications, settings and times.

Cognitive training involves the introduction of the individual as a mediator in strategies employed to promote transfer of learning.

Cognitive Strategies

Cognitive training refers to programmed changes in the cognitive processes that occasion and are presumed to mediate behavioral change (Bolstad & Johnson, 1972).

Regardless of how they suppose previous learning to be represented in memory, cognitive theorists generally agree that there are two kinds of generic long term memory structures. The first kind of structure involves the representation of informational data from previous learning, and the second kind of structure refers to sets of procedures for operating on that data. The cognitive factors which affect the transfer of original learning to new situations are (a) the accessibility of original learning represented in memory and (b) the procedures by which original learning is activated or retrieved at the transfer event.

From the cognitive perspective transfer of learning fails to occur automatically when original learning is not accessible or when the procedures for activation or retrieval are deficient. Cognitive training involves methods which may be applicable to the promotion of transfer by providing strategies for making original learning accessible at the transfer event.

It has been suggested that transfer of learning may be promoted by the following cognitive strategies:

1. The provision of self-management strategies.
2. The provision of meta-cognitive strategies.
3. The promotion of causal self-attributions.
4. The provision of multiple passes over the original learning task.
5. The provision of multiple exemplars of original learning.
6. The provision of mnemonic strategies.
7. Teaching by analogy.

All of these methods involve applications of the cognitive construct or information processing theory of transfer. The first four methods emphasize the provision of procedural strategies presumed to promote the cognitive mediation of transfer. The latter three methods emphasize accessibility of original learning for retrieval at the transfer event.

In every case, it is presumed that (a) transfer is

mediated by internal cognitive processes rather than external features of the learning environment and (b) changes in cognitive processes rather than changes in behavior are the objectives of the method.

Self-management. Self-management is a step-by-step strategy to promote either behavioral changes or the cognitive changes that correspond to the solving of a problem. Through instructions, modeling, and reinforcement the student is taught to; (a) monitor his or her own performance, (b) set personal standards for successful completion, (c) reflect on the problem, (d) adopt a performance plan or attack strategy, (e) provide overt or covert verbal self-guidance during application, (f) evaluate his or her performance, (g) self-administer punishment or reinforcement, and (h) practice other applications of the strategy in relevant settings and on relevant occasions (Kanfer, 1971; Kanfer, 1980; Lloyd, 1980). The logic of this approach is that some of the external factors presumed to mediate transfer, such as discriminative stimuli and reinforcement contingencies, are internalized. Overt instructions have proven to be effective discriminative stimuli and, if present in both the original learning and transfer settings, mediators of transfer (Marholin & Siegel, 1978; Rincover & Koegel, 1975). The self-management strategy involves the internalization

of overt instructions as covert self-instructions and presumes their mediation of the transfer process as cognitive rather than environmental discriminative stimuli. In a similar way external reinforcement contingencies are internalized as self-administered punishment and reinforcement and provide matching contingencies in the original learning and transfer settings. Several writers (Keogh & Glover, 1980; Lloyd, 1980; Meichenbaum, 1980; O'Leary, 1980) have noted that transfer of learning has not yet been shown experimentally to be promoted by the acquisition of self-management skills by children receiving a special education.

An exception to this conclusion is provided by Turkewitz et al. (1975) who used a token economy to train self-management of social behaviors and academic skills in eight disruptive school children. While transfer occurred it is impossible to know if the crucial variable was the self-management strategy or the token economy used to establish it. It is also not known if Turkewitz's results are replicable with other handicapped populations such as learning disabled elementary school children.

Meta-cognitive strategies. Flavell (1976) states that meta-cognition "refers to one's knowledge concerning one's own cognitive processes and products" (p. 232). Meyers and Paris (1978) relate meta-cognition to transfer

of learning by redefining meta-cognitive knowledge as "transituational information about the parameters of learning and performance ... that guides the effective selection and implementation of task relevant skills" (p. 680). They argue that general problem solving skills should include components that would foster transfer of learning and suggest that students should be guided to self-knowledge about the adequacies and deficiencies of their own problem solving skills. Deficiencies should be overcome, they suggest, by training students to (a) assess the purpose, scope, and requirements of the problem at hand, (b) reflect on the problem, (c) generate hypotheses, (d) review previous learning about attack strategies and their relevant applications, (e) select or develop a plan of attack, (f) check their own progress, (g) evaluate their results, and (h) remember their strategy for future transfer applications.

The meta-cognitive approach involves making the student aware that transfer is an explicit goal in original learning and that the application of previous learning at a transfer task is an important component of the problem solving process.

In behavioral research instructions to transfer have not been effective in consistently promoting enduring transfer of learning with handicapped populations, unless

those instructions were established as discriminative stimuli (Schwartz & Hawkins, 1970). In addition, O'Leary (1980) and Meichenbaum (1980) have noted that research support for the use of meta-cognitive strategies to effect transfer of learning for children receiving a special education is lacking.

Causal attributions. Rotter (1966) has hypothesized that the power of reinforcers to affect responding is dependent upon whether the subject feels that reinforcement is contingent upon his or her performance or factors beyond his or her control such as fate, luck, powerful others, or God. It is argued that children who attribute successes and failures to their own performances and believe that reinforcement is dependent upon their own performances will show greater persistence in the face of difficulty (Crandall et al., 1965), will develop enhanced perceptions of their self-efficacy and self-worth (Henker et al., 1980), and will be more likely to transfer learned skills to new times and settings (Winett, 1970).

Marholin and Siegel (1978) describe an unpublished study by C.S. Deek in which one group of children were given math problems they could easily succeed at, guaranteeing positive reinforcement; while a second group were given increasingly difficult problems and teacher encouragement to try harder in the face of

difficulty, thus learning to attribute any eventual successes and consequent positive reinforcement to their own efforts. Later all children were given different and difficult problems. The group which had previously been given success only training gave up quickly in the new situation, while those who attributed their successes with previous problems to their own efforts persisted in their efforts in the new situation.

The above study appears to demonstrate the superior durability of previous learning that was self-attributed at a near lateral transfer event. An argument could be made, however, that the second group benefited from a practice effect. It may be that causal attribution is an important variable in the establishment of cognitive strategies to promote transfer when operant conditioning techniques are used to establish those strategies.

Multipass. The "Multipass" system (Schumaker et al., 1982) is largely an improvement of a similar learning technique developed by Robinson (Donald, 1967). Multipass utilizes operant conditioning techniques to teach a cognitive strategy designed to improve reading comprehension. A step-by-step process is involved in the student's acquisition of the Multipass learning strategy, which involves several passes through the reading material with an advanced organizer to direct attention on each pass.

Initially, the teacher tests the deficiencies of the student's present learning habits with respect to the Multipass system. The teacher then describes and models the strategy. The student verbally rehearses the strategy to 100% mastery without prompts. Next, the student practices the strategy while providing self-instruction through overt, and later covert, verbalizations. This practice stage is occasioned by corrective feedback from the teacher. A test of the student's Multipass skills is made, leading either to further practice in grade level materials or termination of practice if criteria are met. A final test on previously unpracticed materials completes the process. Schumaker et al. (1982) report the Multipass strategy is successfully transferred to other learning situations by elementary students receiving special education services.

If replicable across a wide variety of applications the general approach of the multipass strategy would seem to provide one version of the portable coping strategy that Meichenbaum (1977) and others have hoped would be generated by cognitive training research.

Multiple exemplars. We do not know how learning is represented in memory but memories may be represented at more than one location (Snelbecher, 1974). For example,

Royer (1979) speculates that the prospects for retrieval of relevant original learning at the transfer event depends upon the number of locations or ways in which original learning was represented in memory. Practice of original learning at a range of applications is presumed, from this perspective, to enrich memorial representations of original learning and increase the probability of retrieval at the transfer event.

Mnemonic strategies. Travers (1982) distinguishes accessible memories from available memories. The memories to which we have access are fewer than those which are potentially available. Mnemonic strategies aid memory by improving access to available memories. Applied to transfer of learning, mnemonic strategies increase the likelihood of retrieval at the transfer event. The use of mnemonic strategies as methods for the promotion of transfer of learning for handicapped populations has been limited. Higbee (1979) states that handicapped learners are unable to generalize the use of mnemonic devices as learning strategies. This conclusion seems premature in that generalization may not be spontaneous, but may be possible if it is programmed using techniques similar to those employed in the establishment of the "Multipass" system.

The following techniques should be considered as

candidates for promoting transfer:

1. Active rehearsal, or repeated recall, of original learning prior to retrieval at the transfer event (Erdelyi & Kleinbard, 1978).

2. The use of covert verbal mediators to organize original learning in association with familiar words, concepts, experiences or items (Montague et al., 1966).

3. The use of internal visual images to organize original learning in association with familiar places, experiences, or items (Paivio & Rowe, 1970).

4. The use of meaningful categories to organize original learning (Travers, 1982).

Applied research is needed to test the usefulness of these methods with handicapped populations in transfer of learning tasks.

Teaching by analogy. Royer (1979) suggests the use of similes, metaphors, analogies and allegories as devices to promote figural transfer.

The analysis and development of teaching by analogy situations, and evaluations of their usefulness in promoting transfer for handicapped populations, remains as an area in need of future research and development efforts.

Summary: Cognitive Strategies

The only experimental situations in which transfer of learning has been shown to be promoted by cognitive

training are those situations where operant conditioning techniques were used to establish the cognitive training program. As a result, it is not known if the transfer of learning was promoted by (a) the cognitive training program, (b) the coincidental effects of the behavioristic program used to establish the cognitive training program, or (c) the effects of these two types of programs working in tandem.

Additionally, different types of cognitive programs may have differential effects on different types of transfer. A considerable amount of further research is required before we will begin to understand whether and when cognitive training techniques promote transfer of learning in all its complexity.

CHAPTER 3

METHOD

In this chapter descriptions of the subjects, materials, and procedures of the study are provided.

Subjects

Four elementary school children participated in the study. The learning assistance teacher at their school initially nominated eight students from the roster of grade four- and five-level students who were described informally by their teachers as being learning disabled and poor transferrers. The students' individual education programs divided their school day between a special education program in one setting and the normal program in the regular classroom. Letters seeking parental permission for participation in the study were answered affirmatively for five of the eight children. Of these five, four were permitted, by the principal, to participate in the study.

The UCLA Marker Variable Guide (Keogh, 1983) was used to establish criteria for subject descriptions. The guide lists descriptive, substantive, topical, and

general background markers for describing samples and subjects in learning disabilities research. This approach provides a basis for comparing samples across research studies. Descriptive, substantive, and topical markers specific to individual subjects are summarized in Table 1. General background and descriptive markers of the sample are presented below.

Insert Table 1 about here

The sample was made up of three females and one male. They ranged in age from ten years and four months to ten years and eleven months. The boy was enrolled in a grade five class. The three girls shared a grade four class. All had received learning assistance in Language Arts for at least two school years prior to the study. All were receiving learning assistance in Language Arts at the time of the study. The four students were described by their teachers as being healthy, emotionally and socially adjusted, well behaved, and regular in their attendance. The subjects attended a public elementary day school located in a Canadian west coast provincial capital. The school is situated in a middle class residential district

Table 1

Subject Markers

Markers	Subjects			
	A	B	C	D
Descriptive Markers				
Gender	M	F	F	F
Chronological Age ^a	129	131	131	124
Grade Level	5	4	4	4
Language	Eng.	ESL ^b	Eng.	Eng.
Ethnicity	C ^c	V ^d	C	C
Educational History				
Grade Retention	-	-	X	-
School Change	-	-	-	X
Special Services				
Grade 1	X	X	X	-
Grade 2	X	X	X	-
Grade 3	X	X	X	X
Grade 4	X	X	X	X

Note. X = Applicable. - = Not applicable.

^aIn months. ^bEnglish as a Second Language.

^cCaucasian. ^dVietnamese.

Table 1 continued

Markers	Subjects			
	A	B	C	D
Descriptive Markers continued				
Present Special Educational Services ^e				
Reading	-	-	-	X
Spelling	X	-	X	-
ESL ^f	-	X	-	-
Substantive Markers				
CTBS ^g				
Vocabulary	8.2	2.9	3.6	4.0
Comprehension	7.0	3.3	2.3	3.8
Punctuation	6.6	5.5	5.5	5.1
Capitalization	5.9	4.1	3.5	4.1
Usage	4.9	3.7	2.1	3.7
Spelling	4.9	5.6	2.9	3.9

^eAt the time of the study. ^fLearning assistance based on ESL materials. ^gCanadian Test of Basic Skills (teacher administered) grade-equivalent scores.

Table 1 continued

	Subjects			
	A	B	C	D
Substantive Markers continued				
Final Report Card ^h				
Reading	B	D	D	D
Listening	B	C	C-	C-
Speaking	B	C-	C-	C-
Writing	C+	D	D	C-
Spelling	C-	D	D	C-
Math	C+	C-	C-	C-
Science	B	C-	D	D
Social Studies	B	C	C	C
Physical Education	C+	B	C+	B
Art	C+	C+	C+	C+
Music	C+	C	B	C+

^hIssued immediately following the conclusion of this study. B = above average achievement. C = average achievement. D = below average achievement in need of improvement.

Table 1 continued

Markers	Subjects			
	A	B	C	D
	Topical Markers ⁱ			
Attention Span	-	-	D	D
Auditory Processing	-	-	D	D
Fine Motor				
Coordination	D	-	-	-
Gross Motor				
Coordination	D	-	-	-
Language				
Decoding	-	D	D	D
Sequencing	-	D	-	D
Oral Speech	-	D	-	D
Word Recognition	-	-	D	D
Comprehension	-	-	-	D
Transfer of Learning	D	D	D	D
Visual Memory	D ^j	-	D	-

Note. D = deficit. ⁱInformal teacher assessment.

^jGrade three assessment by a speech therapist.

near a university campus. The students' learning deficits, other than those indicated by their scores on the Canadian Test of Basic Skills reported in Table 1, were based on informal teacher assessments or stale dated data rather than on recent formal diagnoses by trained personnel.

Materials

The experimental settings were (a) a small seminar room within the school's learning assistance center and (b) a grade four and a grade five classroom.

The materials that were used in the study are presented, together with the experimental protocols, in Appendix A. They include (a) the reward table used during protocol number one, (see Figure 6 in Appendix A) at the original learning event, (b) the stimulus and response sheets presented to the subjects during the original learning events (see Table 3 in Appendix A), (c) the window card used to present the stimulus items during the original learning events (pictured in Figure 7 in Appendix A), (d) the problem solving strategies presented during protocols three and four at the original learning events (see Table 4 in Appendix A), and (e) the answer sheets presented

to the subjects during the transfer events (see Figures 9 and 10 in Appendix A). The distraction task sheets used between trials at the original learning events consisted of repeated rows of random letters or numbers. The tokens used to determine the amount of monetary reinforcement at the conclusion of protocol number one consisted of small circular cardboard cutouts with ' $\frac{1}{2}\phi$ ' printed on them.

A sample of the form used to collect information about each of the subjects is included in Appendix B. The form used to organize the records of the subjects' performances over the duration of the study is included in Appendix C.

Procedure

Design. A multi-element baseline design replicated across four subjects was employed to assess transfer of learning from a special education setting to the regular classroom. Daily comparisons of subjects' performances under four alternating experimental conditions were made over an eight week period. Each of the four conditions represented a different program to promote transfer of learning across the experimental settings. The relative effects of the transfer programs were measured for parallel learning

tasks. The tasks were at the same level of difficulty and complexity within each week. Each transfer program was in effect once during each week for each subject over eight consecutive weeks. Within each week the order of experimental conditions was determined by a random assignment procedure (see schedule in Appendix D) to offset the possible effects of any one sequential order. The tasks were varied from one week to the next to counteract the possibility of cumulative effects across weeks.

Experimental conditions. A description of the four experimental conditions follows:

1. The first transfer program consisted of the following steps (a complete description is provided by Protocol 1 in Appendix A) at the original learning event: (a) the learning task was presented to the scheduled subject by the experimenter in the special education setting during a one-to-one session, (b) the learning task was repeatedly presented with corrective feedback and 100% positive tangible reinforcement for correct responding until the subject achieved a criterion of 100% correct responding on three consecutive trials. The following day, or not less than four hours later on the same school day, at

the transfer event, the task was presented to the subject (a complete description is provided by Protocol 5 in Appendix B) in the regular classroom, by the regular classroom teacher, in a cosmetically different format, without corrective feedback or reinforcement for correct responding.

This transfer program, from both cognitive and behavioristic perspectives, is unlikely to promote transfer since (a) no cognitive strategy is supplied or trained and (b) there is a systematic effort to mismatch stimulus contexts, remove or disguise potential discriminative stimuli, mismatch reinforcement contingencies, and provide original learning within a highly determinable and undelayed reinforcement schedule and a single exemplar paradigm.

2. The second transfer program consisted of the following steps (a complete description is provided by Protocol 2 in Appendix B) at the original learning event: (a) the learning task was presented to the scheduled subject (see Appendix E) by the experimenter in the special education setting during a one-to-one session, (b) the task was repeatedly presented with corrective feedback and 100% positive verbal reinforcement for correct responding until the

the subject achieved a criterion of 100% correct responding on three consecutive trials. The following day, or not less than four hours later on the same school day, at the transfer event, the task was presented to the subject in the regular classroom by the experimenter who acted as a contingency manager providing 100% positive verbal reinforcement for correct responding in a one-to one session at the students classroom seat (see Appendix B, Protocol 6).

This transfer program, from the behavioristic perspective, has the greatest likelihood of promoting positive transfer since (a) the task materials and experimenter are potential discriminative stimuli, (b) the reinforcement contingencies are matched, (c) the one-to-one sessions together with the identical task materials and the same experimenter provide similar stimulus contexts in both settings.

Together, these first two conditions test the theory of identical elements. If the theory is correct then condition one ought to result in significantly less transfer than condition two. If on the other hand, there is no significant difference between these two conditions then the applicability of the theory of identical elements to the transfer of academic learning across educational settings must

be questioned.

3. The third transfer program consisted of the following steps (a complete description is provided by Protocol 3 in Appendix B) at the original learning event: (a) the learning task was presented by the experimenter in the special education setting during a one-to-one session, (b) the task was repeatedly presented with the provision of instructions on the use of a problem solving strategy at the start of each trial until the subject achieved a criterion of 100% correct responding on three consecutive trials. No corrective feedback or reinforcement was provided for either correct responding or strategy use. The following day, or not less than four hours later on the same school day, at the transfer event, the task was presented to the subject in the regular classroom, by the regular classroom teacher, in a cosmetically different format, with no corrective feedback, reinforcement for correct responding or repetition of instructions (see Appendix B, Protocol 7).

From a behavioristic perspective this transfer program ought to be less successful than the second program described above because (a) the stimulus contexts are mismatched, (b) potential discriminative stimuli are disguised or removed, (c) there are no

matching, indeterminable or delayed reinforcement contingencies provided, and (d) original learning occurs in a single exemplar paradigm. From a cognitive perspective, however, this program ought to be more effective than either conditions one or two since a cognitive strategy is repeatedly provided during original learning. The strategy provided is comparable to a mnemonic device, algorithm or rule and takes the place of the operant techniques provided at original learning in conditions one and two.

4. The fourth transfer program consisted of the following steps (a complete description is provided by Protocol 4 in Appendix B) at the original learning event: (a) the learning task was presented by the experimenter in the special education setting during a one-to-one session, (b) the task was repeatedly presented with the provision of a problem solving strategy, corrective feedback on the overt use of the strategy, and with 100% positive verbal reinforcement of overt verbalizations evidencing the correct use of the strategy until the subject achieved a criterion of 100% correct responding on three consecutive trials. The following day, at the transfer event, the task was presented to the subject in the regular classroom, by the regular classroom teacher,

in a cosmetically different format, with no corrective feedback, reinforcement for correct responding or repetition of instructions (see Appendix B, Protocol 8).

From the behavioristic perspective this program ought to be less successful than program number two since (a) there is a systematic effort to mismatch stimulus contexts, (b) potential discriminative stimuli are disguised or removed, (c) reinforcement contingencies are mismatched, and (d) original learning was provided with a highly determinable and undelayed reinforcement schedule and a single exemplar paradigm. From a cognitive perspective this program ought to be the most successful since a cognitive strategy is repeatedly trained during original learning.

Together, these last two conditions test the cognitive approach to the transfer of learning. Condition four combines a strategy with an operant technique to establish the strategy. If the cognitive approach is correct then conditions three and four ought not to be significantly different. In addition, these latter two conditions, when compared to condition two, ought to be significantly better at

promoting the transfer of academic learning across educational settings for these subjects. If, on the other hand, the theory of identical elements provides a better explanation of the transfer process it would be evidenced by the superior promotion of transfer under condition two when compared to either conditions three or four.

Learning tasks. The learning tasks (for a complete description see Appendix A, Protocols 1 to 4) presented within each weekly interval were made up of single letters, letter combinations, single numbers, number combinations, words or arithmetic questions. These are the basic elements of almost all academic learning.

The operant training methods used in conditions one and two paralleled special education teaching patterns for rote memory tasks such as the acquisition of the basic arithmetic or phonics facts. The subjects listened, read and wrote during original instruction until mastery was achieved. Later they were asked to recall in writing what they had learned in another setting. The strategies instructed or trained in conditions three and four also paralleled teaching patterns. The strategies included (a) phonic vowel

digraph generalizations, (b) arithmetic skip counting generalizations, and (c) addition, subtraction, and multiplication operations.

In all cases the tasks were ones for which the subjects had all of the necessary prerequisite skills for both the original and transfer event responses.

Within each weekly interval the tasks were designed to be of equivalent difficulty and complexity and of parallel type.

The presentation of the original learning tasks involved four steps (see Protocols 1 to 4 in Appendix A): (a) presenting the subject with a visual stimulus complex and associating it with a visual response complex, (b) providing a distraction task for thirty seconds, (c) presenting the stimulus complex to elicit the response complex in the form of an exact written reproduction by the subject, (d) repeating the above procedure until criterion was reached for the condition in effect. The use of the window card and distraction task between trials at original learning prevented the subjects from spontaneously using a rehearsal strategy or a strategy based on any relationship between the stimulus and response complex elements other than one supplied by the experimenter. The window card also guided a subject's

apprehension of the individual stimulus elements on the stimulus sheet in each condition. That a strategy is being successfully learned, rather than merely repeated together with a rote memorization of the stimulus elements, is indicated when the subject fills in the response sheet by columns. If the subject fills in the response sheet by rows this indicates they are not using the strategy supplied.

The transfer event (see Protocols 5 to 8 in Appendix A) involved a single presentation of the stimulus complex to elicit the response complex as a written reproduction by the subject.

Data collection. The number of response complex items correctly reproduced by each subject at the transfer events, under each experimental condition, were recorded. All responses, at original learning or at the transfer event, for each subject each day, were collected.

Limitations.

Three types of limitations to the study are discussed below.

Time. The interval between the original learning event and the transfer event varied between, but not within weeks. During the fourth, fifth, and seventh

weeks the transfer event occurred in the afternoon about four hours after original learning. During the other weeks the transfer event occurred in the morning about twenty four hours after original learning. This variation in the timing of the transfer event resulted from variations in the length of the school week over the duration of the study. Since time of day and the durability of original learning have been suggested as variables affecting the transfer process (O'Leary et al., 1969; Turkewitz et al., 1975) this time variation precludes intra-interval comparisons. This means that comparisons may be made between conditions across weeks but not between weeks.

Selection. The small size of the sample and the fact that it was not randomly selected obviate generalizations beyond the participants in the study.

Assumptions. Several ways of thinking about the transfer process have been left outside the scope of this study. For example, the effects of affective responses to academic materials and the role of verbal or other types of encoding during the learning and transfer processes have not been discussed. It

has been assumed that since all original learning met with a mastery criterion of 100% correct responding on three consecutive trials, the characteristics of acquisition, other than the experimental variables, were equivalent.

CHAPTER 4

RESULTS

The criterion of 100% correct responding on three consecutive trials was met at each and every original learning event in the special education setting.

The total numbers of the correct responses by the children at the transfer events in the regular classroom were recorded. Table 2 shows these totals for the four transfer conditions over eight weeks.

Insert Table 2 about here

To clarify the meaning of Table 1 the four experimental conditions are recapitulated below.

Condition 1 consisted of a transfer program where the characteristics of the original learning event were mismatched with those of the transfer event. Money was used to reinforce original learning and corrective feedback was provided.

Condition 2 consisted of a transfer program where the characteristics of the original learning event were matched with those of the transfer event. Corrective feedback and verbal reinforcement were provided at original learning.

Table 2

Total Numbers of Correct Responses by Children in
Four Transfer Conditions

Week	Condition			
	1	2	3	4
1	12	12	24	18
2	20	13	17	24
3	19	9	13	22
4	19	17	21	21
5	8	15	16	16
6	17	18	24	22
7	13	22	23	21
8	16	17	20	21

Note. $n = 4$. Maximum number of correct responses = 24

Condition 3 consisted of a transfer program where the characteristics of the original learning event were mismatched with those of the transfer event. Instruction in the use of a transfer strategy was provided at original learning. There was no corrective feedback or verbal reinforcement.

Condition 4 consisted of a transfer program where the characteristics of the original learning event were mismatched with those of the transfer event. Training in the use of a transfer strategy was provided at the original learning event. Evidence of the use of the strategy was required to meet criterion at original learning and corrective feedback and verbal reinforcement for strategy use were provided.

Comparisons were made between the following conditions: 1 and 2, 3 and 4, 3 and 2, and 4 and 2. As well, the behavioral conditions (1 plus 2) were summed and compared to the sum of the cognitive conditions (3 plus 4). These comparisons were made in two ways; graphically and statistically. They are illustrated graphically in Figures 2, 3, 4, and 5. The data in Table 2 do not meet the prerequisite assumptions of parametric statistical procedures. As

a result, the Wilcoxin matched pairs signed-ranks test in which the region of rejection is two-tailed was used.

There was no significant difference in the number of correct responses given by the children at the transfer event in condition 1 as compared to condition 2 ($z = -.0845$, $p = .9326$).

There was no significant difference in the number of correct responses given by the children at the transfer event in condition 3 as compared to condition 4 ($z = -.3145$, $p = .7532$).

There were significantly more correct responses given by the children at the transfer event in condition 3 than in condition 2 ($z = -2.5205$, $p = .0117$).

Also, there were significantly more correct responses given by the children at the transfer event in condition 4 than in condition 2 ($z = -2.3105$, $p = .0209$).

When the sum of the correct responses given by the children at the transfer event in conditions 1 and 2 were compared with the sum of the correct responses given in conditions 3 and 4, there were significantly more correct responses given in the latter case ($z = -2.5205$, $p = .011$).

Figure Caption

Figure 2. A graphic comparison of conditions 1 and 2.

Figure 2

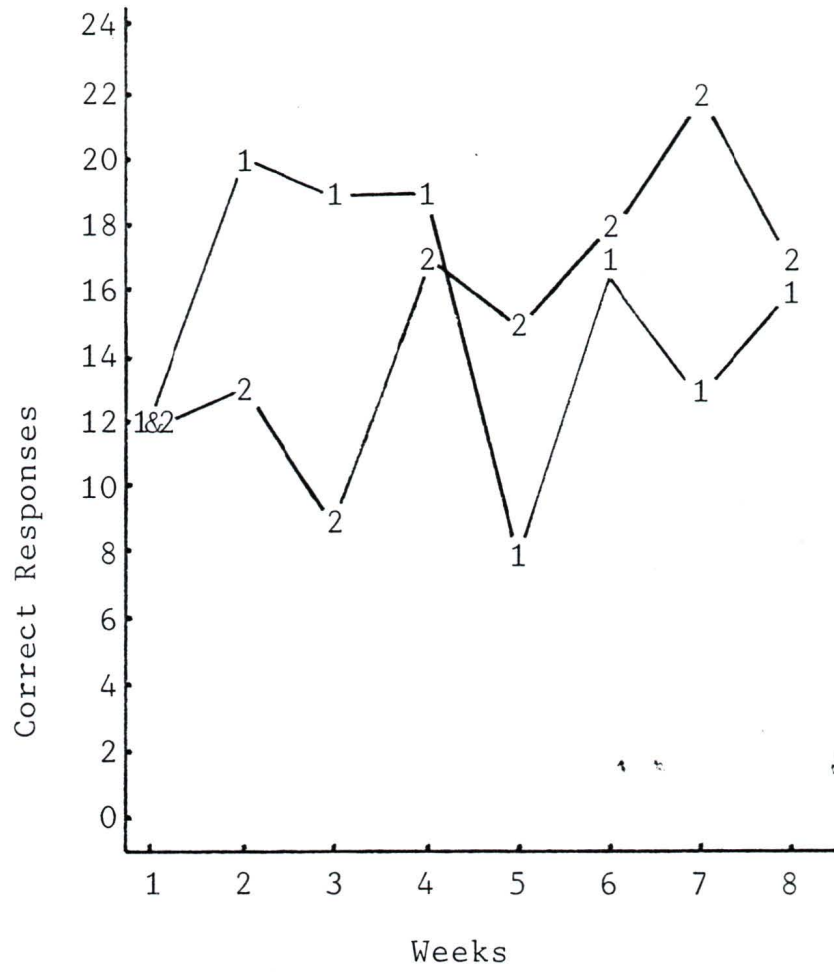

Figure Caption

Figure 3. A graphic comparison of conditions 3 and 4.

Figure 3

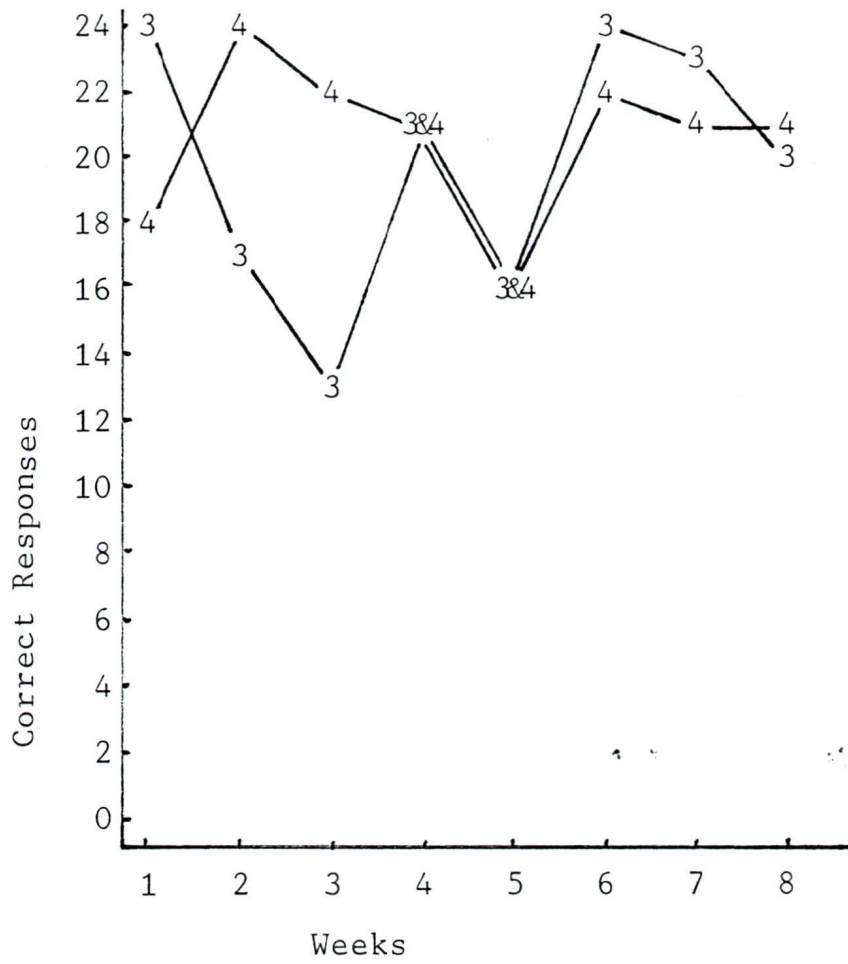

Figure Caption

Figure 4. A graphic comparison of conditions 2 and 3 and 4.

Figure 4

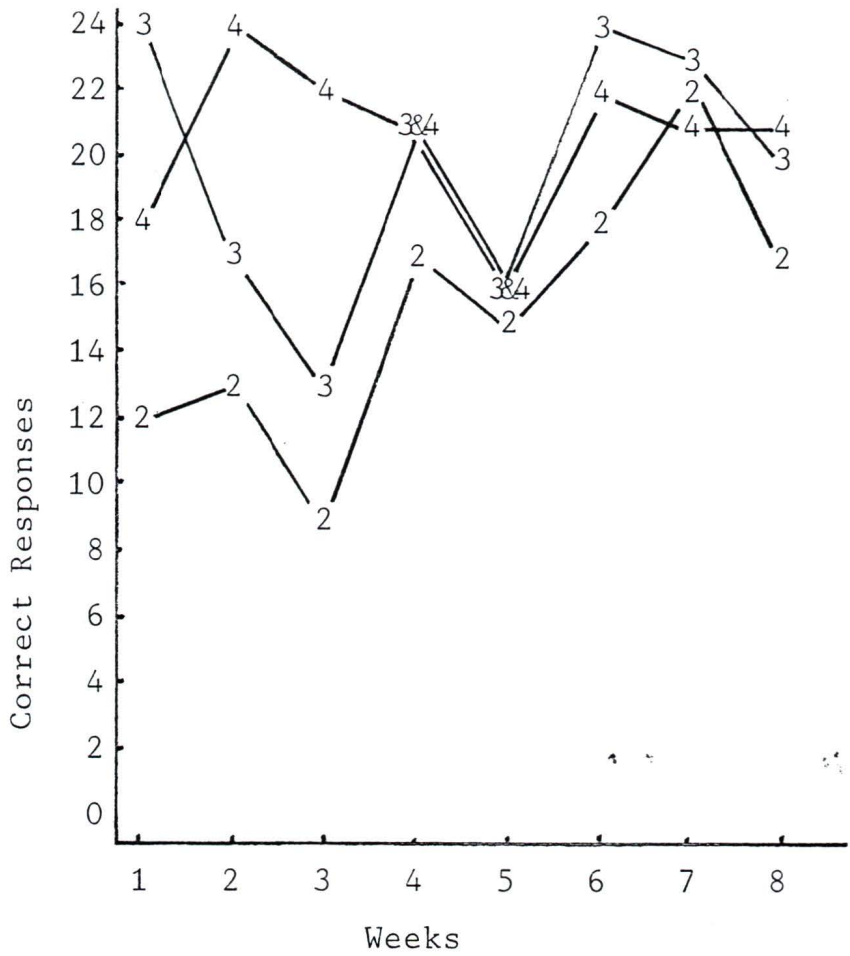
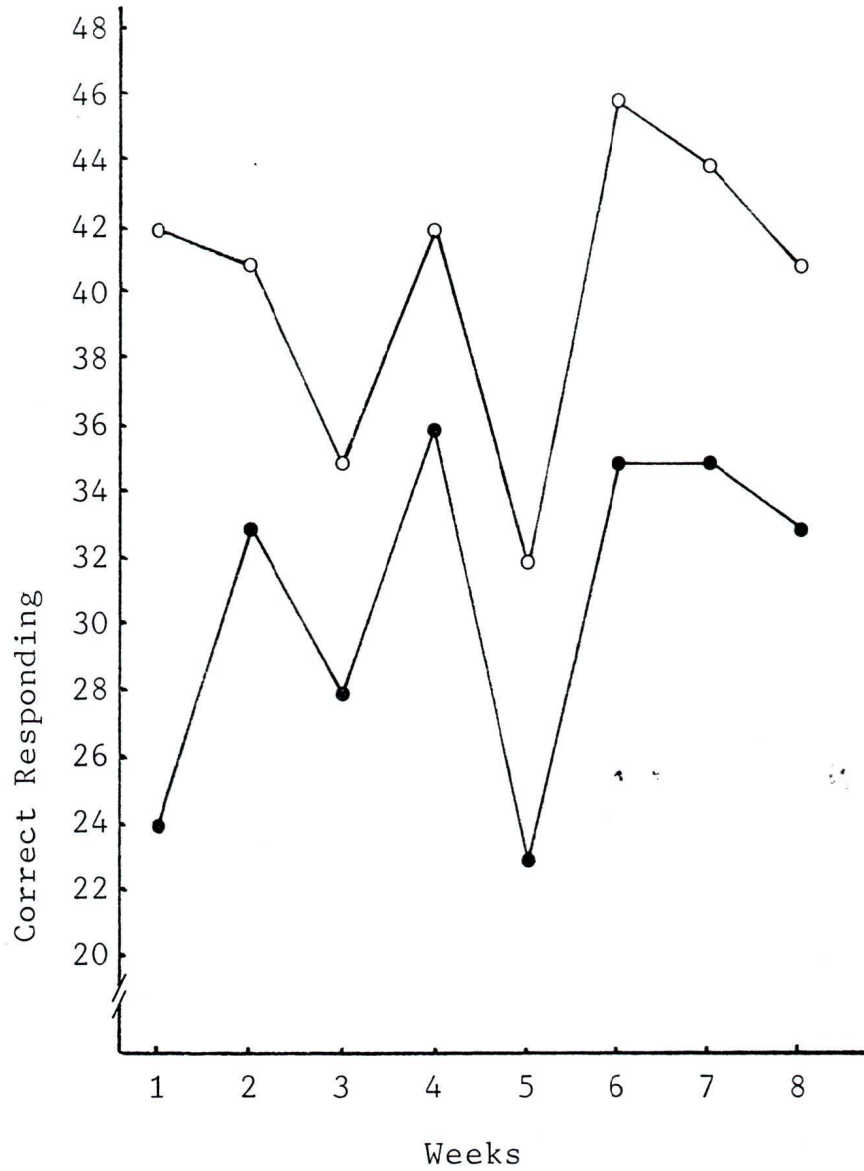

Figure Caption

Figure 5. A graphic comparison of the sum of conditions 1 and 2 with the sum of conditions 3 and 4.

Figure 5



Note. Conditions 1 and 2 combined = ●—●.

Conditions 3 and 4 combined = ○—○. $\underline{n} = 4$.

Insert Figures 2, 3, 4, and 5 about here

Other bilateral comparisons (3 and 1, 4 and 1) and grouped comparisons (1 plus 3 and 2 plus 4, 1 plus 4 and 3 plus 2) are possible but not meaningful in relation to the research question.

CHAPTER 5
DISCUSSION

The purpose of this last chapter is threefold. First, it is to interpret the results of the study and answer the research question. Second, it is to discuss the importance of the study in the context of the theoretical and practical issues raised by previous writers. Third, it is to suggest directions for future research efforts.

Interpretation

The research question asked in this study is whether the transfer of academic learning across educational settings for four learning disabled elementary school children is best explained by (a) external environmental factors, (b) internal cognitive processes, or (c) a combination of internal and external factors. The results of the study provide us with an answer to the research question.

For the four children who were the subjects of the study, transfer of learning was best explained by internal cognitive processes. This conclusion is substantiated by the following five point analysis of

the results.

First, all of the subjects met with a criterion of 100% correct responding on three consecutive trials at every original learning event. Consequently, any differences in performance at the transfer event can be safely ascribed to factors other than incomplete acquisition at original learning.

Second, there was no significant difference in the amount of transfer by the children in conditions one and two. These two conditions systematically mismatched (condition 1) and matched (condition 2) the environmental characteristics at original learning and the transfer event. Other variables such as the children's use of a covert strategy, order of treatment effects, or subject variability were under experimental control. A finding of no significant difference between these two conditions directly contradicts what might be reasonably predicted from a behavioristic explanation of transfer. For these four children, the matching of external environmental factors across educational settings did not effect greater transfer of their academic learning.

Third, there was no significant difference in the

amount of transfer by the children in conditions three and four. These two conditions involved the provision of instructions (condition 3) and training (condition 4) in the use of a task-specific problem solving strategy. Training included corrective feedback and external reinforcement procedures until the overt use of the strategy was observed at a criterion level. A finding of no significant difference between these two conditions contradicts the contention that cognitive strategies to promote the transfer of academic learning for learning disabled children must be established using behavioristic methods to be maximally effective.

Fourth, there was significantly greater transfer by the children in conditions three and four than in condition two. Conditions three and four systematically mismatched the environmental characteristics at original learning and the transfer event. In addition, they both provided a task-specific problem solving strategy to promote transfer. Condition two matched environmental characteristics across educational settings to promote transfer but provided no strategy. For these children, the use of a task-specific problem

solving strategy to promote the transfer of their academic learning across educational settings had significantly greater effect than the matching of environmental characteristics.

Fifth, there was significantly greater transfer by the children in conditions three and four (combined) than in conditions one and two (combined). These children were better able to transfer their academic learning across educational settings when they had been provided with a task-specific problem solving strategy than when they had not.

All of these findings support a conclusion that the transfer of learning process, for these four learning disabled elementary school children, is best understood in terms of internal cognitive factors. This conclusion is limited to the transfer of academic learning across educational settings.

Importance

This study has important practical and theoretical implications. Three widely held tenets as to how transfer across educational settings is explained and promoted may need to be reexamined.

The behavioristic approach to transfer may be

seriously limited. Research support for the transfer of adaptive classroom behaviors across educational settings by matching environmental characteristics is robust (Baer & Wolf, 1970; Marholin & Siegel, 1978; Schwartz & Hawkins, 1970). Many writers have extended the significance of this research to explain the transfer of academic learning (Andersen & Redd, 1980; Marholin & Siegel, 1978; Stokes & Baer, 1977). Additionally, techniques which have been demonstrated to promote the transfer of behaviors across settings have been repackaged and presented as programs for the generalization of academic learning (Andersen & Redd, 1980; Harris & Handleman, 1980). These writers may have presumed too much. It may be that, while the transfer of adaptive classroom behaviors is mediated by external environmental factors; the transfer of academic learning is mediated by internal cognitive factors. Different kinds of programs to promote transfer may be needed depending upon what we hope will be transferred. The failure to distinguish between the transfer of behaviors and academic learning may be a consequence of studies which demonstrated the transfer of academic learning using behavioristic

methods but which also included the provision of task-specific problem solving strategies at original learning (Schumaker et al., 1982; Turkewitz et al., 1975; Walker & Buckley, 1972).

A second argument made by some writers is that cognitive strategies have failed to mediate transfer (Lloyd, 1980; Meichenbaum, 1980). This pessimistic conclusion may be premature. While it is true that general problem solving strategies have often failed to promote transfer across settings for learning disabled elementary school children, it is also true that task-specific problem solving strategies have often been successful in promoting the transfer of academic learning. It may be that cognitive strategies should be differentiated into general and specific types and that these two types may play different roles in the transfer of learning process.

Some writers (Baer et al., 1968; Conway & Bucher, 1976; Marholin & Siegel, 1978) have assumed that the use of behavioristic methods to establish cognitive strategies is essential to the transfer process for academic learning. This may be true only in part. Good behavioristic methodology prescribes overt evidence of

strategy acquisition at original learning and tends to make general problem solving approaches specific to the tasks at hand so they can be observed and measured. It may be that it is not environmental factors which are instrumental in the transfer process for academic learning, but the specificity of the problem solving strategy involved and the assuredness of its acquisition at original learning.

Future Directions

The following suggestions should be considered as possible points of departure for future research efforts in this area:

1. Further research is needed to clarify the possible differences between the transfer of behaviors and the transfer of academic learning for learning disabled elementary school children.

2. The possibility of differences in the effectiveness of task-specific as opposed to general problem solving strategies in the transfer of learning process should be investigated.

3. Research is also needed to explore the developmental and affective factors influencing the transfer of learning process for learning disabled

children.

4. In order to simplify and clarify the relationships between different research studies the transfer hexahedron should be developed as a well defined data-based model of the transfer process. In addition, the parameters identified in Chapter 2 (page 21) should be verified experimentally.

Conclusion

That students will transfer their academic learning is a central expectation of the educative process. It is especially important that ways and means are found to promote the transfer of academic learning across educational settings for learning disabled children. If, as the results of this study indicate, the transfer of academic learning for learning disabled elementary school children is mediated by internal cognitive processes rather than environmental factors; then a major shift in contemporary thinking about transfer is necessary.

LITERATURE CITED

- Ames, L.B. (1983). Learning disability: Truth or Trap? Journal of Learning Disabilities, 16, 19-20.
- Andersen, B.L. & Redd, W.L. (1980). Programming generalization through stimulus fading with children participating in a remedial reading program. Education and Treatment of Children, 3, 297-314.
- Arbitman-Smith, R. & Haywood, H.C. (1980). Cognitive education for learning disabled adolescents. Journal of Abnormal Psychology, 8, 51-64.
- Atthowe, J.M. (1973). Behavior innovation and persistence. American Psychologist, 28, 34-41.
- Ansubel, D.P. (1968). Education Psychology: A Cognitive View. New York: Holt, Rinehart and Winston.
- Ayers, A.J. (1972). Improving academic scores through sensory integration. Journal of Learning Disabilities, 5, 338-342.
- Baer, D.M. & Wolf, M.M. (1970). The entry into natural communities of reinforcement. In Control of Human Behavior (Vol. 2). Glenview, Ill.: Scott-Foresman.
- Baer, D.M., Wolf, M.M. & Risley, T.R. (1968). Some current dimensions of applied behavior analysis. Journal of Applied Behavior Analysis, 1, 91-97.

- Bandura, A. (1969). Principles of Behavior Modification. New York: Holt, Rinehart and Winston.
- Bolstad, O.D. & Johnson, S.M. (1972). Self-regulation in the modification of disruptive classroom behavior. Journal of Applied Behavior Analysis, 5, 443-454.
- Bower, G.H. & Hilgard, E.R. (1981). Theories of Learning. New York: Appleton.
- Bruner, J.S., Goodnow, J.J., & Austin, G.A. (1956). A Study of Thinking. New York: Wiley Co.
- Bryan, T.H. (1978). Social relationships and verbal interactions of learning disabled children. Journal of Learning Disabilities, 11, 107-115.
- Bryan, T.H., Pearl, R., Zimmerman, D. & Matthews, F. (1982). Mothers' evaluations of their learning disabled children. The Journal of Special Education, 16, 149-159.
- Cawley, J.F. Goodstein, H.A., Fitzmaurice, A.M., Lepore, A.V., Sedlak, R., & Althaus, V. (1976). Project Math: Levels I, II, III, & IV. Tulsa: Educational Development Corporation.

- Conway, J.B. & Bucher, B.D. (1976). Transfer and maintenance of behavior change in children. In E.J. Mash, L.A. Hamerlynk, & L.C. Handy (Eds.), Behavior Modification and Families. New York: Bruner-Mazel.
- Crandall, V.C., Crandall, V.J. & Katovsky, W. (1965). Children's beliefs in their own control of reinforcement in intellectual-academic achievement situations. Child Development, 36, 91-109.
- Cruickshank, W.M. (1977). Learning Disabilities in Home, School and Community. Syracuse: Syracuse University Press.
- Cruickshank, W.M. (1983). Learning disabilities: A neurophysiological dysfunction. Journal of Learning Disabilities, 16, 27-29.
- Definition of Learning Disabilities. (1981). Victoria, B.C.: South Vancouver Island Association for Children with Learning Disabilities.
- Donald, M. (1967). SQ3R in grade 7. Journal of Reading, 11, 33-43.
- Ellis, H.C. (1965). The Transfer of Learning. New York: Macmillan Co.

- Erdelyi, M.H. & Kleinbard, J. (1978). Has Ebbinghaus decayed with time?: The growth of recall over days. Journal of Experimental Psychology: Human Learning and Memory, 4, 275-289.
- Feuerstein, R. Rand, Y., & Hoffman, M. (1979). The dynamic assessment of retarded performers: The Learning Potential Assessment Device; theory, instruments and techniques. Baltimore: University Park Press.
- Flavell, J.H. (1976). Metacognitive aspects of problem solving. In L.B. Resnick (Ed.), The Nature of Intelligence. Hillsdale, N.J.: Laurence Erlbaum Associates.
- Forness, S.R. & Cantwell, D.P. (1982). DSM-III Psychiatric diagnoses and special education categories. The Journal of Special Education, 16, 49-63.
- Forness, S.R. & Esveldt, K.C. (1975). Classroom observation of children with learning and behavior problems. Journal of Learning Disabilities, 8, 49-52.
- Foster, C.G., Ysseldyke, J.E. & Reese, J.H. (1975). I wouldn't have seen it if I hadn't believed it. Exceptional Children, 41, 469-473.

- Gage, N.L. & Berliner, D.C. (1979). Educational Psychology. Chicago: Rand McNally.
- Gagné, R.M. (1970). The Conditions of Learning. New York: Holt, Rinehart and Winston.
- Gagné, R.M. (1964). Problem solving. In A.W. Melton (Ed.), Categories of Human Learning. New York: Academic Press Co.
- Gillespie, P.H. & Sitko, M.C. (1974). A decision-making model for training preservice teachers in diagnostic-prescriptive teaching. Bloomington: Center for Teaching the Handicapped.
- Guilford, J.P. (1967). The Nature of Human Intelligence. New York: McGraw-Hill Book Co.
- Hammill, D.D., Bartel, N.R. & Bunch, G.O. (1984). Teaching Children with Learning and Behavior Problems (Canadian Ed.). Toronto: Allyn and Bacon.
- Hammill, D.D., Leigh, J.E., McNutt, G., & Larsen, S.C. (1981). A new definition of learning disabilities. Learning Disabilities Quarterly, 4, 336-342.
- Hardy, M.I., McLeod, J., Minto, H., Perkins, S.A., & Quance, W.R. (1971). Standards for educators of exceptional children in Canada. Toronto: Crainford.

- Harlow, H.F. (1949). The formation of learning sets. Psychological Review, 56, 51-65.
- Harris, S.L. & Handleman, J.S. (1980). Programming for generalization: Educating autistic children and their parents. Education and Treatment of Children, 3, 51-63.
- Henker, B., Whalen, C.K. & Henshaw, S.P. (1980). The attributional contexts of cognitive intervention. Exceptional Education Quarterly, 1, 17-30.
- Higbee, K.L. (1979). Recent research on visual mnemonics: Historical roots and educational fruits. Review of Educational Research, 49, 611-629.
- Hoffding, H. (1892). [Outlines of Psychology] (M.E. Lowndes, trans.). London: Macmillan.
- Kanfer, F.H. (1971). The maintenance of behavior by self-generated stimuli and reinforcement. In A. Jacobs & L.B. Sachs (Eds.), The Psychology of Private Events. New York: Academic Press.
- Kanfer, F.H. (1980). Self-management methods. In F.H. Kanfer & A.P. Goldstein (Eds.), Helping People Change. Toronto: Pergamon Press.
- Karoly, P. (1980). Operant methods. In F.H. Kanfer & A.P. Goldstein (Eds.), Helping People Change. Toronto: Pergamon Press.

- Kendler, H.H. & Kendler, T.S. (1962). Vertical and horizontal processes in problem solving. Psychological Review, 69, 1-16.
- Keogh, B.K. (1983). Classification, compliance and confusion. Journal of Learning Disabilities, 16, 25.
- Keogh, B.K. & Glover, A.T. (1980). The generality and durability of cognitive training effects. Exceptional Education Quarterly, 1, 75-82.
- Kirk, S.A. & Bateman, B. (1962). Diagnosis and remediation of learning disabilities. Exceptional Children, 29, 73-77.
- Kirk, S.A. & Kirk, W.D. (1983). On defining learning disabilities. Journal of Learning Disabilities, 16, 20-21.
- Koegel, R.L. & Rincover, A. (1977). Research on the difference between generalization and maintenance in extra-therapy responding. Journal of Applied Behavior Analysis, 10, 1-12.
- Lloyd, J. (1980). Academic instruction and cognitive behavior modification: The need for attack strategy training. Exceptional Education Quarterly, 1, 59-69.
- Lloyd, J., Hallahan, D.P. & Kauffman, J.M. (1980). Learning disabilities: A review of selected topics. The Fourth Review of Special Education. New York: Grune and Stratton.

- Mann, L., David, C.H., Boyer, C.W., Metz, C.M. & Wolford, B. (1983). LD or not LD, that was the question : A retrospective analysis of child service demonstration centers' compliance with the federal definition of LD. Journal of Learning Disabilities, 16, 14-17.
- Macfarlane, D.H. (1930). The role of kinesthesia in maze learning. University of California Publications in Psychology, 4, 277-305.
- Marholin, D. & Siegel, L.J. (1978). Beyond the law of effect: Programming for maintenance of behavior change. In D. Marholin (Ed.), Child Behavior Therapy. New York: Gardner Press.
- Marholin, D., Siegel, L.J. & Phillips, D. (1976). Treatment and transfer: A search for empirical procedures. In M. Hersen, R.M. Eisler, & P.M. Miller (Eds.), Progress in Behavior Modification, Vol. 3. New York: Academic Press.
- McKinney, J.D. & Feagans, L. (1983). Adaptive classroom behavior of learning disabled students. Journal of Learning Disabilities. 16, 360-367.
- McLeskey, J., Reith, H.J. & Polsgrove, L. (1980). The implications of response generalization for improving the effectiveness of programs for learning disabled children. Journal of Learning Disabilities, 13(5), 59-62.

- McLeod, J. (1983). Learning disability is for educators. Journal of Learning Disabilities, 16, 23-24.
- Meichenbaum, D.H. (1977). Cognitive Behavior Modification. New York: Plenum Press.
- Meichenbaum, D.H. (1980). Cognitive behavior modification with exceptional children: A promise yet unfulfilled. Exceptional Education Quarterly, 1, 82-88.
- Meyers, M. & Paris, S. (1978). Children's metacognitive knowledge about reading. Journal of Educational Psychology, 70, 680-690.
- Montague, W.E., Adams, J.A. & Kiess, H.O. (1966). Forgetting and natural language mediation. Journal of Experimental Psychology, 72, 829-833.
- Moran, M.R. (1976). The teacher's role in referral for testing and interpretation of reports. Focus on Exceptional Children, 8(6), 1-15.
- Myklebust, H.R. (1983). Toward a science of learning disabilities. Journal of Learning Disabilities, 16, 17-18.
- Neisser, U. (1963). The imitation of man by machine. Science, 139, 193-197.

- Nelson, C.M., Worell, J. & Polsgrove, L. (1973). Behaviorally disordered peers as contingency managers. Behavior Therapy, 4, 270-276.
- O'Leary, S. (1980). A response to cognitive training. Exceptional Education Quarterly, 1, 89-94.
- O'Leary, K.D., Becker, W.C., Evans, M.B., Sandargas, S.A. (1969). A token reinforcement program in a public school: A replication and systematic analysis. Journal of Applied Behavior Analysis, 2, 3-13.
- Osgood, C.E. (1949). The similarity paradox in human learning: A resolution. Psychological Review, 56, 132-143.
- Ottenbacher, K. (1982). Sensory integration therapy: affect or effect. American Journal of Occupational Therapy, 36, 571-578.
- Paivio, A. & Rowe, E.J. (1970). Noun imagery, frequency, and meaningfulness in verbal discrimination. Journal of Experimental Psychology, 85, 264-269.
- Postman, L. (1964). Short term memory and incidental learning. In A.W. Melton (Ed.), Categories of Human Learning, New York: Academic Press.

- Premack, D. & Anglin, B. (1973). On the possibilities of self control in man and animals. Journal of Abnormal Psychology, 81, 137-151.
- Richey, D.D. & McKinney, J.D. (1978). Classroom behavioral styles of learning disabled boys. Journal of Learning Disabilities, 11, 297-302.
- Rose, T.L., Lessen, E.I. & Gottlieb, J. (1982). A discussion of transfer of training in mainstreaming programs. Journal of Learning Disabilities, 15, 162-165.
- Rotter, J.B. (1966). Generalized expectancies for internal vs. external control of reinforcement. Psychological Monographs, 80, Whole No. 609.
- Royer, J.M. (1979). Theories of the transfer of learning. Educational Psychologist, 14, 53-69.
- Schumaker, J.B., Deshler, D.D., Alley, G.R., Warner, M.M. & Denton, P.H. (1982). Multipass: a learning strategy for improving reading comprehension. Learning Disability Quarterly, 5, 295-304.
- Schwartz, M.L. & Hawkins, R.P. (1970). Application of delayed reinforcement procedures to the behavior of an elementary school child. Journal of Applied Behavior Analysis, 3, 85-96.

- Simon, H.A. & Newell, A. (1971). Human problem solving: The state of the theory in 1970. American Psychologist, 26, 145-159.
- Snelbecher, G.E. (1974). Learning Theory, Instructional Theory, and Psychoeducational Design, New York: McGraw-Hill.
- Stokes, T.F. & Baer, D.M. (1977). An implicit technology of generalization. Journal of Applied Behavior Analysis, 10, 349-367.
- Tharp, R.G. & Wetzel, R.J. (1969). Behavior Modification in the Natural Environment. New York: Academic Press.
- Thorndike, E.L. & Woodworth, R.S. (1901). The influence of improvement in one mental function upon the efficiency of other functions. Psychological Review, 8, 247-261.
- Tolman, E.C. (1932). Purposive Behavior in Animals and Man. New York: Century.
- Torgensen, J.K. & Dice, C. (1980). Characteristics of research on learning disabilities. Journal of Learning Disabilities, 13, 531-535.
- Travers, R.M.W. (1982). Essentials of Learning. New York: Macmillan.

- Tucker, J., Stevens, L.J., & Ysseldyke, J.E. (1983).
Learning disabilities: The experts speak out.
Journal of Learning Disabilities, 16, 6-31.
- Turkewitz, H., O'Leary, K.D. & Ironsmith, M. (1975).
Generalization and maintenance of appropriate
behavior through self-control. Journal of
Consulting and Clinical Psychology, 43, 577-583.
- Ulman, J.D. & Sulzer-Azaroff, B. (1975). Multielement
baseline design in educational research. In
E. Ramp & G. Semp (Eds.), Behavior Analysis:
Areas of Research and Application. Englewood
Cliffs, N.J.: Prentice-Hall.
- Wahler, R.G. (1969). Setting generality: Some specific
and general effects of child behavior therapy.
Journal of Applied Behavior Analysis, 2, 239-246.
- Walker, H.M. & Buckley, N.K. (1972). Programming
generalization and maintenance of treatment
effect across time and settings. Journal of
Applied Behavior Analysis, 5, 209-224.
- Wincze, J.P., Leitenberg, H. & Agras, W.S. (1972).
The effects of token reinforcement and feedback
on the delusional verbal behavior of chronic
paranoid schizophrenics. Journal of Applied
Behavior Analysis, 5, 247-262.

- Winett, R.A. (1970). Attribution of attitude and behavior change and its relevance to behavior therapy. The Psychological Record, 20, 17-32.
- Winett, R.A. & Winkler, R.C. (1972). Current behavior modification in the classroom: Be still, be quiet, be docile. Journal of Applied Behavior Analysis, 5, 499-504.
- Woodruff, A.D. (1964). The use of concepts in teaching and learning. Journal of Teacher Education, 15, 81-99.
- Ysseldyke, J.E., Algozzine, B., Shinn, M.R. & McGue, M. (1982). Similarities and differences between low achievers and children classified as learning disabled. The Journal of Special Education, 16, 73-85.
- Ysseldyke, J.E., Thurlow, M., Graden, J., Wesson, C., Algozzine, B. & Deno, D. (1983). Generalizations from five years of research on assessment and decision-making: The University of Minnesota Institute. Exceptional Education Quarterly, 4, 75-93.
- Zeitlin, S. (1982). Assessing coping behavior in children with learning disabilities. The Exceptional Child, 29(1), 43-51.

Appendix A:

Protocols

PROTOCOL NUMBER 1

RESEARCH PROJECT: Transfer of Learning.

SETTING: Learning Assistance Classroom.

CONDITION: 1.

RESEARCHER: "R"

R: Say, " I'm going to show you some letters (numbers, words, or shapes, as the case may be) and then ask you to write all of them down afterwards. After I have shown you all of the letters I will ask you to cross out numbers (letters of the alphabet if the task involves words, numbers, or shapes) on this this sheet for about thirty seconds (display proper distraction task). Then I will ask you to write down on the answer sheet all of the letters that you can remember, exactly as they were shown to you. I will continue to show you the letters until you write then down correctly three times in a row."

R: " The sooner all of the letters are written down correctly, three times in a row, the larger will be your final reward (display reward table, Figure 6). Each time you write down the letters you will be told which letters are incorrect and correct."

R: " Let me repeat. First, I will show you some letters.

Insert Figure 6 about here

Figure Caption

Figure 6. Reward table displayed with protocol 1.

Figure 6Reward Table

on trial number.....subject receives
3	\$1.00
4	\$.90
5	\$.80
6	\$.70
7	\$.60
8	\$.50
9	\$.40
10	\$.30
11	\$.20
12 or more	\$.10

Second, I will give you some numbers to cross out. Third, I will ask you to write down all of the letters exactly as they were shown to you. Fourth, I'll tell you which letters are correct and reward you for the correct ones. We'll keep on doing this until you write down all the letters correctly three times in a row. Do you have any questions?"

- R: Provide clarification if necessary.
- R: Present stimulus item (stimulus items, see Table 3) one row at a time using a window card (window card, see Figure 7). Present each row for 5 seconds.
- R: Present the distracter task sheet and ask the subject to cross out numbers two at a time. For example, "On the first row cross out 3 and 15, 7 and 22, 11 and 19.." Do not give the numbers 1 and 26 in the same pair and do not give adjacent numbers in a pair. Ask the subject to cross out pairs of numbers until thirty seconds has elapsed. Pause between pairs while the subject completes the task.
- R: Present the answer sheet (answer sheets, see Table 3) and say, "Write down all the letters you can remember exactly as they were shown to you". Provide a token reinforcer for each correct letter as it is written on the response sheet. Each token reinforcer is valued at $\frac{1}{4}$ cent.

- R: When the subject has completed the answer sheet note the correct responses and provide corrective feedback for the incorrect or unfinished responses. For example, if the response is correct say, "The letter 'F' is correct here," and if the response is incorrect or unfinished say, "This should be the letter 'F' here."
- R: Repeat the entire process, excluding the introduction, until the subject responds correctly on three consecutive trials.
- R: When the subject has responded correctly for three consecutive trials provide reinforcement according to the reward table (Figure 6) and tokens received.

Insert Table 3 about here

Insert Figure 7 about here

Table 3

Complete Set of Stimulus and Response Items

Week	Protocol	Sheet Type	
		Stimulus	Response
1	1	J U I S G R F Q	J U
1	2	S O U L R N T P	S O
1	3	I R L T N V P X	I R
1	4	A C B E D F F H	A C

Note. Sample stimulus and response sheets follow.

Table 3 continued

Complete Set of Stimulus and Response Items continued

Week	Protocol	Sheet Type	
		Stimulus	Response
2	1	3 4	3 4
		2 7	
		5 6	
		4 9	
2	2	4 5	4 5
		3 4	
		5 6	
		2 3	
2	3	2 6	2 6
		3 7	
		1 5	
		4 8	
2	4	1 3	1 3
		4 6	
		6 8	
		7 9	

Table 3 continued

Complete Set of Stimulus and Response Items continued

Week	Protocol	Sheet Type	
		Stimulus	Response
3	1	27	97
		41	18
		4	9
		19	47
3	2	56	85
		40	11
		82	24
		4	2
3	3	77	92
		0	7
		49	18
		14	11
3	4	86	55
		14	10
		2	0
		48	25

Table 3 continued

Complete Set of Stimulus and Response Items continued

Week	Protocol	Sheet Type			
		Stimulus		Response	
4	1	EI	AI	EI	AI
		ZD	JR		
		FN	KM		
		JB	PG		
4	2	UI	IE	UI	IE
		PF	VT		
		HJ	KS		
		WF	LR		
4	3	AE	OE	AE	OE
		FC	BN		
		GM	CD		
		HT	DM		
4	4	OA	EA	OA	EA
		RD	LF		
		SP	ML		
		TD	NR		

Table 3 continued

Complete Set of Stimulus and Response Items continued

Week	Protocol	Sheet Type			
		Stimulus		Response	
5	1	WIND	FORT	WIND	FORT
		PILL	ABOVE		
		CLOCK	LAWN		
		NAME	MATH		
5	2	TUNE	HOME	TUNE	HOME
		HEAD	SUIT		
		RADIO	BOIL		
		BOAT	GHOST		
5	3	CARD	SHOT	CARD	SHOT
		FAME	BOTH		
		GRASS	CLOWN		
		HALL	DONE		
5	4	PETE	LATE	PETE	LATE
		LEAP	EIGHT		
		MEET	FAIL		
		NIECE	GREY		

Table 3 continued

Complete Set of Stimulus and Response Items continued

Week	Protocol	Sheet Type			
		Stimulus		Response	
6	1	3	7	3	7
		<u>+2</u>	<u>+2</u>	<u>+2</u>	<u>+2</u>
		13	10		
		<u>+ 2</u>	<u>+ 6</u>		
6	2	19	15		
		<u>+ 5</u>	<u>+ 8</u>		
		5	6		
		<u>+1</u>	<u>+4</u>		
6	3	8	8	8	8
		<u>-6</u>	<u>-7</u>	<u>-6</u>	<u>-7</u>
		15	11		
		<u>- 7</u>	<u>- 5</u>		
6	3	4	5		
		<u>-1</u>	<u>-2</u>		
		18	13		
		<u>- 2</u>	<u>- 9</u>		
6	3	4	4	4	4
		<u>+1</u>	<u>+0</u>	<u>+1</u>	<u>+0</u>
		8	7		
		<u>+2</u>	<u>+1</u>		
6	3	12	10		
		<u>+ 3</u>	<u>+ 2</u>		
6	3	16	13		
		<u>+ 4</u>	<u>+ 3</u>		

Table 3 continued

Complete Set of Stimulus and Response Items continued

Week	Protocol	Sheet Type			
		Stimulus		Response	
6	4	5	5	5	5
		<u>-3</u>	<u>-2</u>	<u>-3</u>	<u>-2</u>
		8	9		
		<u>-4</u>	<u>-3</u>		
		11	13		
		<u>- 5</u>	<u>- 4</u>		
		14	17		
		<u>- 6</u>	<u>- 5</u>		

Table 3 continued

Complete Set of Stimulus and Response Items continued

Week	Protocol	Sheet Type			
		Stimulus		Response	
7	1	479	610	479	610
		223	137		
		695	402		
		751	356		
7	2	934	420	934	420
		685	551		
		227	433		
		130	537		
7	3	350	126	350	126
		562	247		
		774	368		
		986	489		
7	4	879	320	879	320
		756	443		
		633	566		
		510	689		

Table 3 continued

Complete Set of Stimulus and Response Items continued

Week	Protocol	Sheet Type			
		Stimulus		Response	
8	1	NOUNS	DREAM	NOUNS	DREAM
		MAUVE	PLEAT		
		KNOWN	SPOIL		
		THOUGH	FRAUD		
8	2	PEACE	ROUTE	PEACE	ROUTE
		BREATH	FEIGN		
		SHIEK	HOUND		
		LOUSE	JUICE		
8	3	GREW	CLAY	GREW	CLAY
		COULD	GREAT		
		CROON	GRAIL		
		CLUES	GEISHA		
8	4	SOUPS	DRIED	SOUPS	DRIED
		DOUBLE	SKIER		
		DOUBT	SIEVE		
		DOUGH	SIEGE		

J	U
I	S
G	R
F	Q

Table 3 (sample answer sheet) continued

J	U

Figure Caption

Figure 7. Illustration of the window card.

Figure 7

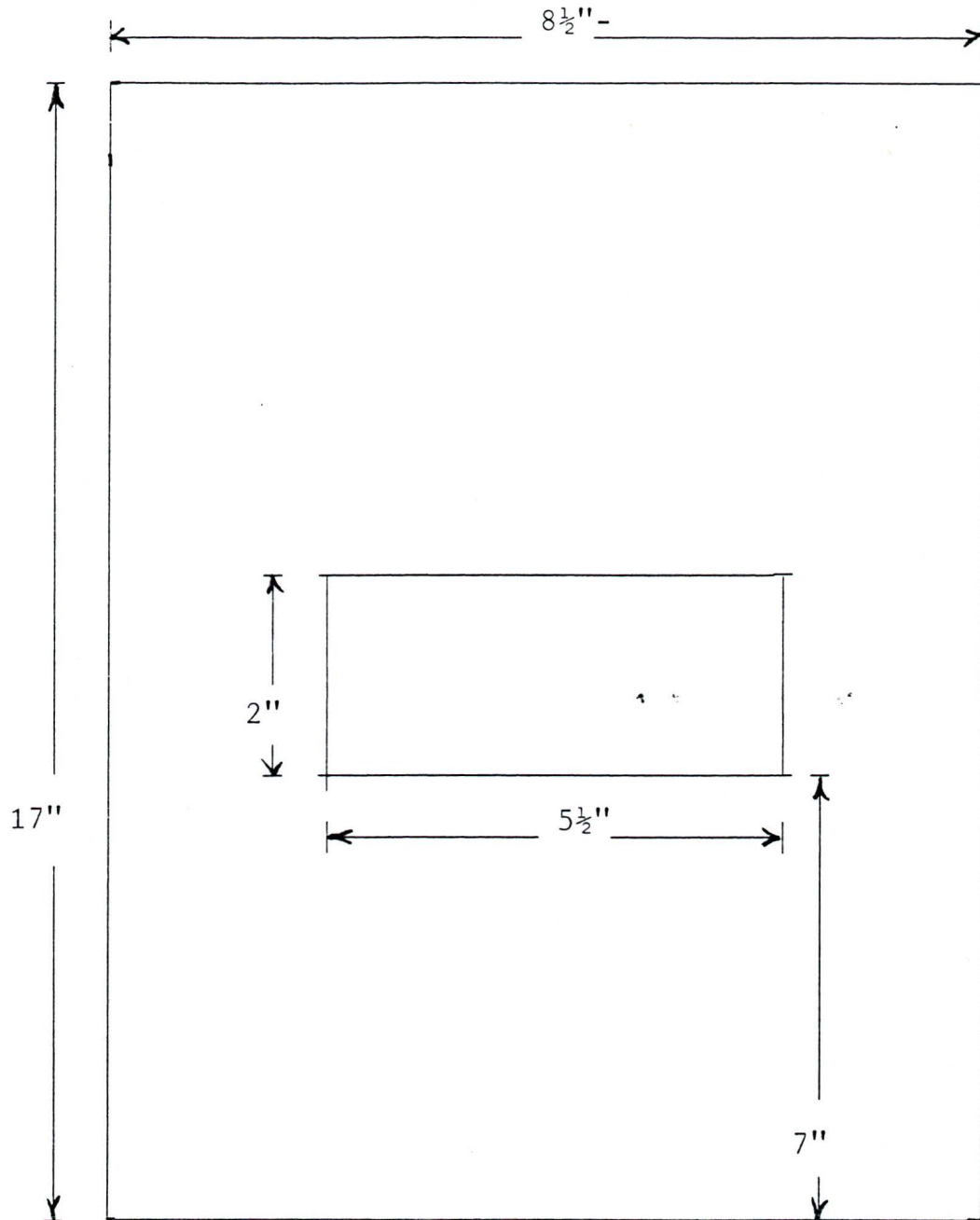

PROTOCOL NUMBER 2

RESEARCH PROJECT: Transfer of Learning.

SETTING: Learning Assistance Classroom.

CONDITION: 2.

RESEARCHER: "R"

R: Say, " I'm going to show you some words (letters, numbers, or shapes, as the case may be) and then ask you to write all of them down afterwards. After I've shown you all of the words I will ask you to cross out letters of the alphabet (numbers if the task involves letters) on this sheet for about thirty seconds (display appropriate distraction task). Then I will ask you to write down on the answer sheet all of the words that you can remember, exactly as they were shown to you. I will continue to show you the words until you write them all down correctly three times in a row."

R: " The sooner all of the words are written down correctly, three times in a row, the better you will have done. Each time you write down the words you will be told which words are incorrect and correct."

R: " Let me repeat. First, I will show you some words. Second, I will give you some letters to cross out.

Third, I will ask you to write down all of the words exactly as they were shown to you. Fourth, I'll tell you which words are correct. We'll keep on doing this until you write down all of the words correctly three times in a row. Do you have any questions?"

R: Provide clarification if necessary.

R: Present stimulus item (stimulus items, Table 3) one row at a time using a window card (window card, Figure 7). Present each row for 5 seconds.

R: Present the distracter task sheet and ask the subject to cross out letters two at a time. For example, "On the first row cross out c and m, g and q, s and x..." Do not give the letters a and z in the same pair and do not give adjacent letters in the same pair. Ask the subject to cross out pairs of letters until thirty seconds has elapsed. Pause between pairs while the subject completes the task.

R: Present the answer sheet (answer sheets, Table 3) and say, "Write down all the words you can remember exactly as they were shown to you."

- R: When the subject has completed the answer sheet note the correct responses and provide corrective feedback for the incorrect or unfinished responses. For example, if the response is correct say, "The word 'some' here is correct," or if the response is incorrect or unfinished say, "This should be the word 'some'."
- R: Each correct response written on the answer sheet should receive a positive verbal reinforcement immediately after it is written by the subject. Positive verbal reinforcement should also be given at the correct completion of the task each time that it occurs.
- R: Repeat the entire process, excluding the introduction, until the subject responds correctly on three consecutive trials.

PROTOCOL NUMBER 3

RESEARCH PROJECT: Transfer of Learning.

SETTING: Learning Assistance Classroom.

CONDITION: 3.

RESEARCHER: "R"

R: Say, " I'm going to show you some numbers (letters, words, or shapes, as the case may be) and then ask you to write all of them down afterwards. Each time that I show you the numbers I'm going to give you some information that will help you to be able to remember them (problem solving strategies, Table 4). After I've shown you all of the numbers I will ask you to cross out letters of the alphabet (numbers if the task involves letters) on this sheet for about thirty seconds (display appropriate distraction task). Then I will ask you to write down on the answer sheet all of the numbers that you can remember, exactly as they were shown to you. I will continue to show you the numbers and give you information that will help you to remember them until you write them all down correctly three times in a row."

R: " The sooner all of the numbers are written down correctly, three times in a row, the better you will have done."

PROTOCOL NUMBER 3

- R: " Let me repeat. First, I will show you some numbers and give you some information to help you remember them. Second, I will give you some letters to cross out. Third, I will ask you to write down all of the numbers exactly as they were shown to you. We'll keep on doing this until you write down all of the words correctly three times in a row. Do you have any questions?"
- R: Provide clarification if necessary.
- R: Present the problem solving strategy for the stimulus item (problem solving strategies, Table 4). Then present the stimulus item (stimulus items, Table 3) one row at a time using a window card (window card, Figure 7). Present each row for 5 seconds.
- R: Present the distracter task sheet as per protocols 1 or 2.
- R: Present the answer sheet (answer sheets, Table 3) and say, "Write down all of the numbers you can remember exactly as they were shown to you."
- R: Repeat the entire process, excluding the introduction, until the subject responds correctly on three consecutive trials.

Insert Table 4 about here

Table 4
Problem Solving Strategies

Week 1, Protocol 3. Proceeding down both columns count forward three letters from a vowel and two letters from a consonant to determine the next letter.

Week 1, Protocol 4. Proceeding down both columns count forward one letter from a vowel and two letters from a consonant to determine the next letter.

Week 2, Protocol 3. Proceeding down both columns add one to the number in the first row to determine the number in the second row, subtract two from the number in the second row to determine the number in the third row, and add three to the number in the third row to determine the number in the fourth row.

Week 2, Protocol 4. Proceeding down both columns add three to the number in the first row to determine the number in the second row, add two to the number in the second row to determine the number in the third row, and add one to the number in the third row to determine the number in the fourth row.

Week 3, Protocol 3. Proceeding down both columns subtract the right hand digit in the first row from

Problem Solving Strategies continued

the left hand digit in the first row to determine the number in the second row, multiply the digits in the first row to determine the number in the third row, and add the digits in the first row to determine the number in the fourth row.

Week 3, Protocol 4. Proceeding down both columns add the digits in the first row to determine the number in the third row, subtract the right hand digit in the first row from the left hand digit in the first row to determine the number in the third row, and multiply the digits in the first row to determine the number in the fourth row.

Week 4, Protocol 3. Proceeding down both columns the vowels in the first row can be used to make words (with a long vowel sound and a silent 'e' ending) in the other three rows and the initial consonants of the words so formed follow alphabetical order from the second to the fourth rows.

Week 4, Protocol 4. Proceeding down both columns the vowels in the first row can be used to make words (with an initial consonant, vowel digraph, and final

Problem Solving Strategies continued

consonant) and the initial consonants of the words so formed follow alphabetical order from the second to the fourth rows.

Week 5, Protocol 3. Proceeding down each column the vowel sound changes in each row but the letter making that vowel sound remains constant and the initial consonants of the words in the second to fourth rows follow alphabetical order.

Week 5, Protocol 4. Proceeding down each column the vowel sound remains constant but the digraph making the vowel sound changes in each row and the initial consonants of the words, in the second to fourth rows follow alphabetical order.

Week 6, Protocol 3. Proceeding down the columns the top digit in the first row increases by four in each row in the left column and by three each row in the right column. The bottom digits in both columns increase by one each row. The sign remains constant.

Week 6, Protocol 4. Proceeding down the columns the top digit in the first row increases by three in each row in the left column and by four in each row

Problem Solving Strategies continued

in the right column. The bottom digits in both columns increase by one each row. The sign remains constant.

Week 7, Protocol 3. Proceeding down the left column the first digit in the top row increases by two each row, the second digit increases by one each row, and the third digit increases by two each row. Proceeding down the right column the first digit in the top row increases by one each row, the second digit increases by two each row, and the third digit increases by one each row.

Week 7, Protocol 4. Proceeding down the left column the first digit in the top row decreases by one each row, the second digit decreases by two each row, and the third digit decreases by three each row. Proceeding down the right column the first digit in the top row increases by one each row, the second digit increases by two each row and the third digit increases by three each row.

Week 8, Protocol 3. Proceeding down each column the vowel sound remains constant but the digraph

Problem Solving Strategies continued

making the vowel sound changes in each row. The initial consonants in the first row are the same as those in the second to fourth rows of the diagonally opposed column.

Week 8, Protocol 4. Proceeding down each column the vowels remain constant but the sounds they make change in each row. The initial consonants in the first row are the same as those in the second to fourth rows of the diagonally opposed column.

PROTOCOL NUMBER 4

RESEARCH PROJECT: Transfer of Learning.

SETTING: Learning Assistance Classroom.

CONDITION: 4

RESEARCHER: "R"

R: Say, " I'm going to show you some numbers (letters, words, or shapes, as the case may be) and then ask you to write all of them down afterwards. Each time that I show you the numbers I'm going to give you some information that will help you to be able to remember them (problem solving strategies, Table 4). After I've shown you all of the numbers I will ask you to cross out letters of the alphabet (numbers if the task involves letters) on this sheet for about thirty seconds (display appropriate distraction task). Then I will ask you to write down on the answer sheet all of the numbers that you can remember, exactly as they were shown to you. As you write the numbers down on the answer sheet I want you to tell me, out loud, how you used the information I gave you to remember the numbers. I will continue to show you the numbers and give you information that will help you to remember them until you write them all down correctly three times in a row."

R: " The sooner all of the numbers are written down correctly, three times in a row, the better you will have done. Each time you write down the numbers and tell me, out loud, how you used the information I gave you to remember the numbers; I will tell you if you are using the information correctly or incorrectly."

R: " Let me repeat. First, I will show you some numbers and give you some information that will help you to remember them. Second, I will give you some letters to cross out. Third, I will ask you to write down all of the numbers exactly as they were shown to you. As you write the numbers down on the answer sheet you will tell me, out loud, how you used the information I gave you to help you remember the numbers. Fourth, I will tell you if you are using the information I gave you to help you remember the numbers correctly or incorrectly. We'll keep on doing this until you write down all of the numbers correctly three times in a row. Do you have any questions?"

R: Provide clarification if necessary.

- R: Present the problem solving strategy for the stimulus item (problem solving strategies, Table 4). Then present the stimulus item (stimulus items, Table 3) one row at a time using the window card (window card, Figure 7). Present each row for 5 seconds.
- R: Present the distracter task sheet as per protocols 1 or 2.
- R: Present the answer sheet (answer sheets, Table 3) and say, "Write down all the numbers you can remember exactly as they were shown to you. As you write down the numbers on the answer sheet tell me how you are using the information I gave you to help you remember the numbers."
- R: Each correct use of the problem solving strategy resulting in a correct response on the answer sheet should receive a positive verbal reinforcement immediately after it is written by the subject. Positive verbal reinforcement should also be given at the correct completion of the task (including the correct overt use of the strategy) each time that it occurs.
- R: Repeat the entire process, excluding the introduction, until the subject responds correctly, using the strategy, on three consecutive trials.

PROTOCOL NUMBER 5

RESEARCH PROJECT: Transfer of Learning.

SETTING: Regular Classroom.

CONDITION: 1.

RESEARCHER: "R"

TEACHER: "T"

R: Provide the classroom teacher with the appropriate transfer answer sheet (transfer sheets, Figures 8 and 9). Ask the classroom teacher to give the proper answer sheet to the student and collect it afterwards.

T: Say, "Please fill this in, I cannot help you. Return the answer sheet to me when you are finished."

Insert Figures 8 and 9 about here

Figure Caption

Figure 8. Sample transfer sheet for protocols 1, 3 and 4 (The complete set of transfer answer sheet items is the same as the set of response sheet items listed in Table 3).

Figure Caption

Figure 9. Sample transfer answer sheet for protocol 2 (the complete set of transfer answer sheet items is the same as the set of response sheet items listed in Table 3).

Figure 9

S	O

PROTOCOL NUMBER 6

RESEARCH PROJECT: Transfer of Learning.

SETTING: Regular Classroom.

CONDITION: 2.

RESEARCHER: "R"

R: Present the appropriate answer sheet to the subject (transfer sheets, Figures 8 and 9) and say, "Please fill this in." Each correct response written on the answer sheet should receive a positive verbal reinforcement immediately after it is written by the subject. Positive verbal reinforcement should also be given for completing the task.

PROTOCOL NUMBER 7

RESEARCH PROJECT: Transfer of Learning.

SETTING: Regular Classroom.

CONDITION: 3.

RESEARCHER: "R"

TEACHER: "T"

R: Follow PROTOCOL NUMBER 5.

T: Follow PROTOCOL NUMBER 5.

PROTOCOL NUMBER 8

RESEARCH PROJECT: Transfer of Learning.

SETTING: Regular Classroom.

CONDITION: 4.

RESEARCHER: "R"

TEACHER: "T"

R: Follow PROTOCOL NUMBER 5.

T: Follow PROTOCOL NUMBER 5.

Appendix B:
Subject Information Form

CONFIDENTIAL SUBJECT INFORMATION

175

RESEARCH PROJECT: _____ .
NAME: _____ .
NAME CODE: _____ .
ADDRESS: _____

TELEPHONE: _____ .
DATE OF BIRTH: _____ .
GENDER: _____ .
SCHOOL: _____ .
SCHOOL DISTRICT: _____ .
PRINCIPAL: _____ .
TEACHER: _____ .
LEARNING ASSISTANCE TEACHER: _____ .
OTHER SCHOOL PERSONNEL: _____ .
SCHOOL LOCALE: _____

SCHOOL TYPE: _____ .
MOTHER'S NAME: _____ .
MOTHER'S EDUCATION: _____ .
MOTHER'S EMPLOYMENT: _____ .
FATHER'S NAME: _____ .
FATHER'S EDUCATION: _____ .
FATHER'S EMPLOYMENT: _____ .

CONFIDENTIAL SUBJECT INFORMATION

RESIDENTIAL LOCALE: _____.

RACIAL/ETHNIC HERITAGE: _____.

MOTHER TONGUE: _____.

SOCIOECONOMIC STATUS: _____.

METHODS USED TO ASSESS SES: _____

_____.

PRESENT EDUCATIONAL PLACEMENT: _____

GRADE: _____.

PROGRAM DESCRIPTION: _____

_____.

LEARNING ASSISTANCE PROGRAM DESCRIPTION: _____

_____.

Date started: _____ Projected to finish: _____.

TEACHER COMMENTS: _____

_____.

LEARNING ASSISTANCE TEACHER COMMENTS _____

_____.

CONFIDENTIAL SUBJECT INFORMATION

REPORT CARD INFORMATION:

REGULAR CLASSROOM SUBJECTS

Subject	Date	Score	Comments	Date	Score	Comments
Attendance		Absent:	Late:		Absent:	Late:

LEARNING ASSISTANCE CLASSROOM SUBJECTS

Subject	Date	Score	Comments	Date	Score	Comments
Attendance		Absent:	Late:		Absent:	Late:

OTHER SCHOOL SERVICES: _____

CONFIDENTIAL SUBJECT INFORMATION

EDUCATIONAL HISTORY:

Age-appropriate grade placement: _____.

Retained in a previous grade: _____.

Previous school changes: _____

_____.

Absent from school: _____

_____.

Previous Special Education classification: _____

_____.

Previous Special Education placement: _____

_____.

General Comments: _____

_____.

PHYSICAL AND HEALTH STATUS:

SENSORY DEFICITS: _____

_____.

METHODS USED TO ASSESS SENSORY DEFICITS: _____

_____.

CONFIDENTIAL SUBJECT INFORMATION

PHYSICAL DISABILITIES: _____

_____.

METHODS USED TO ASSESS PHYSICAL DISABILITIES: _____

_____.

NEUROLOGICAL IMPAIRMENT: _____

_____.

METHODS USED TO ASSESS NEUROLOGICAL IMPAIRMENT: _____

_____.

CHRONIC ILLNESS: _____

_____.

MEDICATION OR THERAPY: _____

_____.

INTELLECTUAL ABILITY: _____

_____.

Means of assessment: _____

_____.

Date of assessment: _____

Assessor: _____

Results of assessment: _____

_____.

CONFIDENTIAL SUBJECT INFORMATION

_____ \bar{X} = SD= R= .

READING ACHIEVEMENT: _____

Means of assessment: _____

Date of assessment: _____

Assessor: _____

Results of assessment: _____

_____ \bar{X} = SD= R= .

ARITHMETIC ACHIEVEMENT: _____

Means of assessment: _____

Date of assessment: _____

Assessor: _____

Results of assessment: _____

_____ \bar{X} = SD= R= .

BEHAVIORAL/EMOTIONAL ADJUSTMENT: _____

CONFIDENTIAL SUBJECT INFORMATION

Means of assessment: _____

Date of assessment: _____

Assessor: _____

Results of assessment: _____

_____ \bar{X} = SD= R= _____

TOPICAL MARKERS:

Activity level: _____.

Attention: _____.

Memory: _____.

Fine motor coordination: _____.

Gross motor coordination: _____.

Auditory perception: _____.

Visual perception: _____.

Oral language: _____.

Transfer of learning: _____.

Other: _____.

TOPICAL ASSESSMENTS:

Topic	Means of assessment	Date	Assessor	Results
_____	_____	_____	_____	_____
_____	_____	_____	_____	_____
_____	_____	_____	_____	_____

CONFIDENTIAL SUBJECT INFORMATION

OTHER INFORMATION:

Appendix C:
Protocol Record Form

RESEARCH PROJECT: _____.

RESEARCHER: _____.

DATE: _____
(day) (date) (month) (year)TIME: _____ - _____
(start) (finish)

STUDENT IDENTIFICATION CODE: A B C D

SETTING: Classroom: _____.

Learning Assistance: _____.

TASK: Original learning event: _____.

Transfer event: _____.

Stimulus:

Condition: 1 2 3 4

Protocol: 1 2 3 4 5 6 7 8

Response sheet:

Number used: _____.

Trials to mastery: _____.

COMMENTS:

Appendix D :
Subjects' Schedule
(a typical page)

SUBJECT : A

DAY	SETTING	CONDITION	PROTOCOL	ST. IT. #	ANS. SHT. #	TRANS. SHT. #
Apr 30	LA	3	3	3	3	
May 1	RC	3	7			3
May 1	LA	4	4	4	4	
May 2	RC	4	8			4
May 2	LA	1	1	1	1	
May 3	RC	1	5			1
May 3	LA	2	2	2	2	
May 4	RC	2	6			2
May 7	LA	1	1	5	5	
May 8	RC	1	5			5
May 8	LA	3	3	7	7	
May 9	RC	3	7			7
May 9	LA	2	2	6	6	
May 10	RC	2	6			6
May 10	LA	4	4	8	8	
May 11	RC	4	8			8
May 14	LA	3	3	11	11	
May 15	RC	3	7			11
May 15	LA	2	2	10	10	
May 16	RC	2	6			10
May 16	LA	1	1	9	9	
May 17	RC	1	5			9
May 17	LA	4	4	12	12	
May 18	RC	4	8			12

VITA

Surname: Freeze Given Names: Donald Richard

Place of Birth: Toronto, Ont. Date of Birth: Oct. 5, 1949

Educational Institutions Attended, with Dates of Entering
and Leaving:

QUEEN'S UNIVERSITY, KINGSTON, ONT. 1967 to 1972

UNIVERSITY OF VICTORIA, VICTORIA, B.C. 1982 to 1984

Degrees, Diplomas, Etc., Awarded, with Dates and Names of
Institutions:

B.A. 1971 Queen's University, Kingston

B.Ed. 1972 Queen's University, Kingston

Honors and Awards:

Publications:

PARTIAL COPYRIGHT LICENSE

I hereby grant the right to lend my thesis (the title of which is shown below) to users of the University of Victoria Library, and to make single copies only for such users or in response to a request from the library of any other university, or similar institution, on its behalf or for one of its users. I further agree that permission for extensive copying of this thesis for scholarly purposes may be granted by me or a member of the University designated by me. It is understood that copying or publication of this thesis for financial gain shall not be allowed without my written permission.

Title of Thesis

A COMPARISON OF COGNITIVE AND BEHAVIORAL PROGRAMS TO PROMOTE THE TRANSFER OF LEARNING ACROSS EDUCATIONAL SETTINGS FOR FOUR LEARNING DISABLED CHILDREN

Author



Donald Richard Freeze

Name

Sept 12/84

Date