

The Unidirectional Flow Collective Air Pumps —
A Novel Wave Energy Converter

by

Julio César Rodríguez Macedo

B.S. in Mechanical Engineering, Instituto Tecnológico y de Estudios
Superiores de Monterrey, 2001

A Thesis Submitted in Partial Fulfillment of the
Requirements for the Degree of
MASTER OF APPLIED SCIENCE
in the
Department of Mechanical Engineering.

© JULIO CÉSAR RODRÍGUEZ MACEDO, 2006

University of Victoria

All rights reserved. This thesis may not be reproduced in whole or in part, by
photocopy or other means, without the permission of the author.

The Unidirectional Flow Collective Air Pumps —
A Novel Wave Energy Converter

by

Julio César Rodríguez Macedo

B.S. in Mechanical Engineering, Instituto Tecnológico y de Estudios
Superiores de Monterrey, 2001

Supervisory Committee

Dr. Afzal Suleman, Supervisor (Dept. of Mechanical Engineering,
University of Victoria)

Dr. Brad Buckham, Departmental Member (Dept. of Mechanical Engineering,
University of Victoria)

Dr. Zuomin Dong, Departmental Member (Dept. of Mechanical Engineering,
University of Victoria)

Dr. Alexandre Brolo, External Examiner (Dept. of Chemistry,
University of Victoria)

Supervisory Committee

Dr. Afzal Suleman, Supervisor (Dept. of Mechanical Engineering,
University of Victoria)

Dr. Brad Buckham, Departmental Member (Dept. of Mechanical Engineering,
University of Victoria)

Dr. Zuomin Dong, Departmental Member (Dept. of Mechanical Engineering,
University of Victoria)

Dr. Alexandre Brolo, External Examiner (Dept. of Chemistry,
University of Victoria)

Abstract

A Wave Energy Converter (WEC) is a device designed to harness the ocean wave energy to generate electricity. The commercial viability of WECs depends largely on reducing the cost per kWh to make it competitive against other sources of renewable energy.

This thesis proposes a novel WEC. Simplicity is a key feature of the proposed design with the objective of reducing the manufacturing costs and circumventing issues associated with current WECs, such as installation complexity, impact on marine life, survivability and navigability of vessels.

The performance of the proposed Unidirectional Flow Collective Air Pumps (UF-CAP) WEC has been evaluated using analytical and computational models for a variety of operating conditions. A parametric design study has been carried out to evaluate the proposed design in operation off the coast of Vancouver Island.

Table of Contents

Abstract	iii
Table of Contents	v
List of Tables	vi
List of Figures	vii
Nomenclature	ix
Acknowledgements	x
Preface	xii
1 Introduction	1
1.1 The Case for Wave Energy	1
1.2 Motivation	4
1.3 State of the Art	4
1.4 Research Objectives	7
2 Description of the Proposed Device	8
2.1 Overview	8
2.2 Components Description	10
2.3 Working Principle	11
2.3.1 Intermittency and Dimensionality	12
2.4 Advantages	16
2.5 Proof-of-Concept	19
2.5.1 Experimental Setup	19
2.5.2 Air Chamber Numerical Simulation	20
3 Performance Evaluation of the Device	26
3.1 Assumptions	26
3.2 Analysis	27
3.2.1 Pressure Drop	30

TABLE OF CONTENTS

v

3.2.2 Parametric Analysis	35
4 Technical Data	46
4.1 Mooring Supports	46
4.2 Air Chamber	47
4.2.1 Check Valves	47
4.2.2 Conduits	47
4.3 Turbine	47
5 Conclusions and Future Research	59
References	63
Appendix	70
A UDF for Creating the Inlet Pressure $P(t)$	70
B Check Valves Specifications	72
C UFCAP Patent	73

List of Tables

1.1	Most Developed WEC [17].	5
2.1	Comparison Chart of Characteristics	16
2.2	Air-chamber Models	22
2.3	Property Values	24
3.1	Value of the Fixed Parameters.	36
3.2	Parameter's Value of the Final Design.	45

List of Figures

1.1	Ocean Power Delivery funding history.	3
2.1	UFCAP Components	9
2.2	UFCAP in a 6 air chambers configuration.	11
2.3	Supplying air	13
2.4	Returning air	14
2.5	Air chambers at different pumping zones.	15
2.6	Ocean waves variability	18
2.7	Experiment with two air chambers	20
2.8	Air Chamber's geometry	23
2.9	Air Chamber's mesh	23
2.10	Water mass flow rate on "Pressure Inlet."	25
3.1	Wave effect inside the air chamber.	28
3.2	Equivalence between amplitud and pressures.	29
3.3	UFCAP divided in domains.	30
3.4	Central Conduit ΔP_T	31
3.5	Flow pattern on a "exterior" wind turbine [30]	32
3.6	Pressure relations on a "exterior" wind turbine [30].	33
3.7	Static Pressure on Central Conduit	34
3.8	Wave climate for La Perouse Bank buoy, 2003 [32]	35
3.9	Power in an array $R_{cent}=0.8, N = 55, R_{ch} = 1.2$	38
3.10	Power in an array $R_{cent}=0.9, N = 55, R_{ch} = 1.2$	38
3.11	Power in an array $R_{cent}=1.0, N = 55, R_{ch} = 1.2$	39
3.12	Power in an array $R_{cent}=1.1, N = 55, R_{ch} = 1.2$	39
3.13	Power in an array $R_{cent}=1.2, N = 55, R_{ch} = 1.2$	40
3.14	Power in an array $R_{cent}=1.3, N = 55, R_{ch} = 1.2$	40
3.15	Power in an array $R_{cent}=1.0, N = 35, R_{ch} = 1.2$	41
3.16	Power in an array $R_{cent}=1.0, N = 45, R_{ch} = 1.2$	41
3.17	Power in an array $R_{cent}=1.0, N = 55, R_{ch} = 1.2$	41
3.18	Power in an array $R_{cent}=1.0, N = 65, R_{ch} = 1.2$	42
3.19	Power in an array $R_{cent}=1.0, N = 75, R_{ch} = 1.2$	42
3.20	Power in an array $R_{cent}=1.0, N = 85, R_{ch} = 1.2$	42

3.21	Power in an array $R_{cent}=1.0$, $N = 65$, $R_{ch} = 0.9$	43
3.22	Power in an array $R_{cent}=1.0$, $N = 65$, $R_{ch} = 1.0$	43
3.23	Power in an array $R_{cent}=1.0$, $N = 65$, $R_{ch} = 1.1$	43
3.24	Power in an array $R_{cent}=1.0$, $N = 65$, $R_{ch} = 1.2$	44
3.25	Power in an array $R_{cent}=1.0$, $N = 65$, $R_{ch} = 1.3$	44
3.26	Power in an array $R_{cent}=1.0$, $N = 65$, $R_{ch} = 1.4$	44
4.1	Pipe fitting from Georg Fishers Piping Systems [34].	48
4.2	UFCAP-Assembly	50
4.3	Air-chamber	51
4.4	Mooring Supports	52
4.5	Supply Conduit	53
4.6	Supply Manifold	54
4.7	Central Conduit	55
4.8	Wind Turbine	56
4.9	Floating Valve	57
4.10	Return Manifold	58
B.1	Check Valve Specifications	72
C.1	UFCAP Patent page 1	74
C.2	UFCAP Patent page 2	75
C.3	UFCAP Patent page 3	76
C.4	UFCAP Patent page 4	77
C.5	UFCAP Patent page 5	78
C.6	UFCAP Patent page 6	79
C.7	UFCAP Patent page 7	80
C.8	UFCAP Patent page 8	81
C.9	UFCAP Patent page 9	82

Nomenclature

a_w	amplitud ocean wave
a_{ch}	amplitud water level variation inside the air chamber
Φ	volumetric flow
N	number of air chambers
η	surface elevation [m]
ν	kinematic viscosity [m^2/s]
g	gravity [m/s^2]
ρ_{air}	air density [kg/m^3]
ρ_w	salted water density [kg/m^3]
z	depth [m]
ω	circular frequency [$1/s$]

Acronynms

WEC	Wave Energy Converter
UFCAP	Unidirectional Flow Collective Air Pumps
BCs	Boundary Conditions
GHG	Green House Gases
OWE	Ocean Wave Energy
OWC	Oscillating Water Column

Acknowledgements

I would like to thank my supervisor, Dr. Afzal Suleman, for believing in me, accepting me in his group and for his guidance in professional and personal matters. A special mention to the support he gave me in developing this idea on renewable energy. Thanks to the group, especially to Sandra for all the valuable supports.

A big thanks also to my wife Jany, who is my unconditional source of inspiration and mate in all times. For her support in this project of living and studying in Canada for two years and for her valuable advices and comments to make this thesis more readable.

To Carmen, Tono, Zeudy and Haider who became excellent friends, and with whom we shared so many good moments. Thanks to Lau, Vale, Diego, and Caroll, my Latin American folks, for those awesome “mates” we shared together on Friday’s afternoons and for filling with laughs and wonderful moments my stay at UVic.

Thanks to Ryan for helping me out so many times in adapting me and understanding a different country and for helping whenever I need to say something properly in English (and improperly... he is very good in that also!)

Thanks to all the people who made my stay in Victoria an unforgettable and amazing experience. Thanks God they are so many I can not mention them all here!

Many thanks to the Organizations of American States and LASPAU who funded my studies at UVic.

to my wife Jany,

and my parents,

Ma. Elena and Karlos

Preface

The thesis introduces a novel wave energy converter (WEC) based on the Unidirectional Flow Collective Air Pumps (UFCAP) design. A detailed explanation of the components and working principle are given. This work is intended to be only the first part of a larger and more extensive research. The performance of the device is evaluated only from the perspective of the fluid mechanics.

Design parameters such as dimensions of the system, shape, overall configuration, and the expected power output are discussed in the thesis. Grid integration, energy storage, materials, strengths, and in general structural design are beyond the scope of this study.

The thesis is divided into six chapters. Chapter 1 gives a general introduction to ocean wave energy with some interesting background information on renewable energy and the state of the art regarding Wave Energy Converters. Chapter 2 explains the UFCAP design, its functionality and configuration, and the performance results are given in Chapter 3. Here, the predicted behavior of the UFCAP at different configurations is discussed. Chapter 4 shows drawings of the components and other technical data for its construction. In addition, the last chapter outlines the preliminary conclusions and the recommendations for future work.

Attempting to invent a new product has been an amazing and fulfilling experience. However, in order to apply the disclosed invention to the practical application a work team needs to be formed, and synergies need to be created with industrial partners.

Julio C. Rodriguez

Chapter 1

Introduction

A Wave Energy Converter (WEC) is a device placed at sea, on the surface or submerged, designed to harvest the energy in ocean waves. Ocean wave energy (OWE) is an enormous resource. Worldwide it is in excess of 1000 GW [1]. Such a number has been the inspiration for inventors and researchers to design innovative WECs, and the reason for which hundreds of patents have been filed around the world. However, despite the many number of inventions, just a few concepts have proved to be efficient and commercially viable [2].

The present work introduces a novel WEC, conceptualized to be an integral solution for the problem of making feasible and competitive the harnessing of energy from ocean waves. The goal is to harvest efficiently the ocean wave energy, while addressing issues such as manufacturability, cost, maintenance, and regulatory compliance (naval and environmental).

1.1 The Case for Wave Energy

Ocean Wave Energy (OWE) shares the contemporary interest and relevance associated with renewable energies. Renewable energy industry is experiencing a rapid

growth due to a few key events. One of such events is the **increasing awareness** among individuals and governments on sustainability and environmental issues due to the growing evidence of global warming and its potential negative consequences on plants, animals, climate, and of course, human beings. Global warming is due basically to the Green House Gas (GHG) released to the atmosphere [3]. Most of those emissions come from the use of fossil fuels [4]. One clear example of such a concern is the Kyoto Protocol, which is an agreement between 162 countries [5] around the world, to reduce global CO₂ emissions by six percent below 1990 levels by 2010 [6].

An additional incident that promotes the use of renewables, is a **real need** to somehow satisfy the fast growing world energy demands. Although energy use per capita has not been growing considerably along the last years [7], the total energy use is increasing rapidly. Population growth is the key determinant of such rising demand. Moreover, the continuous **oil prices' rising** during the past few years [8] and the fact that world's proved reserves of oil would last only 41 more years [9][10], indicate that the trend to rising prices will be kept. Finally, as the technology evolves, the cost of generating electricity declines, making such technologies more accessible and competitive.

There are also a number of good reasons which make OWE an attractive resource among the other renewables. First and foremost, wave energy is a concentrated form of energy. While the original solar power levels are of 100 W/m^2 , this irradiation is concentrated in form of ocean waves up to power levels of 10,000 - 50,000 W per meter of wave crest length [11]. The Electric Power Research Institute (EPRI) reported in February 2005 that wave energy can form the basis of an energy supply that is consistent with international objectives of the Kyoto accord [12]. Second, as mentioned in the previous section, ocean waves are an abundant resource. Third, WECs are also a very new technology which means, it is not sufficiently developed yet [13] and it is still possible for an emerging product to compete against the available technologies. By 1995, there were only eight grid-connected demonstration plants ranging in size

from 20 kW to 350 kW with a total of 685 kW of installed operating capacity [14]. As of 2003, worldwide installed energy capacity was 2 MW [15]. Examples are Ocean Power Delivery, Archimedes Wave Swing, and Wavegen which have already produced electricity for the local grid in Europe [12]. In Canada, wave energy has not been properly promoted. From a budget which over 25 years was \$40 million and now is only \$15 millions assigned to renewable energies, the Government of Canada assigns only \$0.1 millions to ocean technologies [6].

The economical perspectives for wave energy are promising. As an example take the case of the Pelamis, from Ocean Power Delivery, Ltd, which is probably the most mature WEC as a commercial product. They started the company in January 1998. In March 2002, OPD Ltd. secured £6 million (EUR 9.8 million) funding from an international consortium of venture capital companies. That was the largest investment of its kind in a wave power company [16]. A summary of the funding is summarized on Figure 1.1.

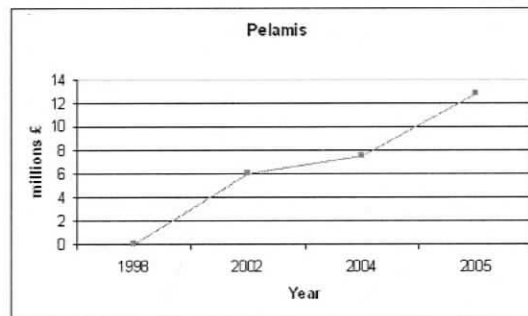

Figure 1.1: Ocean Power Delivery funding history.

For all the aforementioned reasons, wave energy sector has many opportunities to compete in the market.

1.2 Motivation

The development of WEC has been a challenge. There are several factors that contribute to the difficulty in the design and implementation of WECs: *Size* is one fundamental problem. Practically all proposed WECs thus far are very large devices, and obviously this creates operational difficulties. If a device weights 22,000 - 33,000 ton, such as the Wave Dragon, or measures 150 meters, such as the Pelamis [17], handling in general becomes a challenging task. Other factors include manufacturing, installation, transportation, operation, etc. *Survivability* is another concern. The ocean can be a very inhospitable environment due to corrosion, fouling and storms. Then, WECs should be designed to attenuate and support very high loads.

Currently, WECs are an expensive technology. The cost was 5-7 p/kWh (U.S. 8-12 cents/ kWh) in 1998 [1] compared with U.S. 4 cents/ kWh of wind energy or the U.S. 5 cents/ kWh of BCHydro is still expensive and certainly delays its diffusion. Nevertheless, reducing the cost is a challenge since large devices and aggressive environments demand a stronger mechanical structure that increases the cost of the materials. Likewise, all devices are subjected to a variety of regulations. This is why it is desirable that the device has the minimum impact on the marine life and the naval routes.

Therefore, although the interest in using renewable energies to supply our power necessities exists, renewable energies, and in particular OWE, have not experienced the full potential for growth and commercialization. These issues have been motivating factors for the current research on the proposed UFCAP WEC.

1.3 State of the Art

Ocean waves, as a form of energy, provide a full range of possibilities to create a great variety of WECs. The fact that there are so many design variables involved

Table 1.1: Most Developed WEC [17].

Name	Country
Limpet	UK
Azores	Portugal
Energetech	Australia
Mighty Whale	Japan
Pelamis	UK
Wave Dragon	Denmark
AWS	Netherlands
AquaBuOY	U.S
Wavegen	UK

makes it possible to design devices which operate under very different principles. For instance, it is possible to design a device that operates on the water-surface, or under water, off-shore, or on-shore, that uses only the water or the interface with the air, a device that uses the kinetic energy, or the potential energy, or both of them. The possibilities are many, and this is why ocean waves are the form of renewable energy that has more inventions to harvest the resource. Patents in the field are counted by hundreds. However just a few of them have been able to get fully developed [2]. Table 1.1 mention the most developed WECs up to date [17].

Limpet, Azores, Energetech and Mighty Whale, use a principle called Oscillating Water Column (OWC), which uses an air chamber placed at the surface of the ocean having typically two openings: one placed at the bottom part and making contact with the ocean surface and the second typically at the top part where an air turbine is placed. The elevation and falling of the water level at the bottom of the chamber creates an oscillating airflow, which turns a special turbine that accepts and oscillating flow to further generate electricity [18] [19].

This kind of devices can be either near shore such as the plants Limpet in UK or the Azores in Portugal, or offshore such as Mighty Whale in Japan or Energetech in Australia [11].

Although OWC devices are among the most promising approaches to harvest

efficiently the ocean wave energy, they have still some difficulties. The main inconvenience with the on-shore devices is that suitable locations to place big power plants might be limited and when found, such locations are usually apart from roads and access is difficult for the construction machinery [20]. Also, OWC devices typically use a Wells turbine to account for the oscillating airflow, which is less efficient than its equivalent unidirectional turbine [20].

Another promising approach and also one of the most developed is the Pelamis, which consists in several articulated cylindrical sections floating off shore, which are moved relative to each other while the wave passes [17]. Such a relative movement actuates pumps that drive pressurized oil through motors to generate electricity. It has excellent survivability characteristics. However, its efficiency still needs to be improved. Since the sections are fixed in size, it exhibits different efficiencies for different wavelengths. As ocean waves come in all sizes, its overall efficiency is diminished.

The so called Wave Dragon is an over topping device that concentrates waves to further capture them as they spill into a reservoir. The elevated water is then bled through low head turbines, which generate electricity. It is an enormous device with a width of about 300 m [21]. One of the drawbacks is that it is not easily scalable down to supply small necessities [17].

Wave Swing is a submerged device that consists of two concentric vertical cylinders. The external cylinder has a volume of air trapped in their interior. When waves pass, they alter the ambient water pressure changing the pressure of the air inside, and then, forcing the external cylinder to oscillate upward and downward. A linear generator converts the motion into electricity [22]. By being an underwater device, it addresses one of the most important concerns in wave industry, which is the survivability of the device. Under water devices are safer since the susceptibility to storms decrease exponentially with the deep of the water [23]; this, together with the fact that it only has one moving part has given the Wave Swing wide acceptance. However, being a big underwater device could be also a problem since maintenance

might require floating the device to do any repair [17]. Floating a device of such dimensions (9.5m diameter) and weight is not an easy task.

It is really important for WECs to be tunable since waves come in all heights and wavelengths. A lack in tuneability is a current problem as efficiency fall off drastically when the wave climate shifts away from device design points.

Even though the previous listed devices are the most developed, none can compete in price with the electricity generated from fossil fuels.

1.4 Research Objectives

The objective of this work is to design a Wave Energy Converter (WEC) which is able to harness the ocean wave energy efficiently, with due consideration to issues such as manufacturing, access to materials, environmental regulations, size, installation, operation, maintenance, and cost. In other words, this thesis focus on an integral solution to the problem of harnessing energy from the ocean waves to generate electricity.

Chapter 2

Description of the Proposed Device

The essential purpose of this chapter is to introduce and explain the UFCAP (Unidirectional Flow Collective Air Pumps) WEC. A general introduction to the system is discussed first, followed by a detailed explanation of its components and the mode of operation. A summary of the advantages is outlined next. Finally a description of the proof-of-concept, laboratory experiment and computational fluid dynamic model.

2.1 Overview

The UFCAP Wave Energy Converter consists of an array of submerged air-chambers which trap air in its interior. These air chambers are interconnected to a central air turbine through a closed circuit of pipelines or conduits. The array can have any number of air chambers, depending on the capacity required and the local operational conditions. A simplified array with six air-chamber showing the basic elements of the UFCAP WEC is illustrated in Figure 2.1. The size of the system is presented in Chapter 3.

The UFCAP system works on the principle of the pressure differences between separate locations on the ocean to move air from one air-chamber at higher pressure,

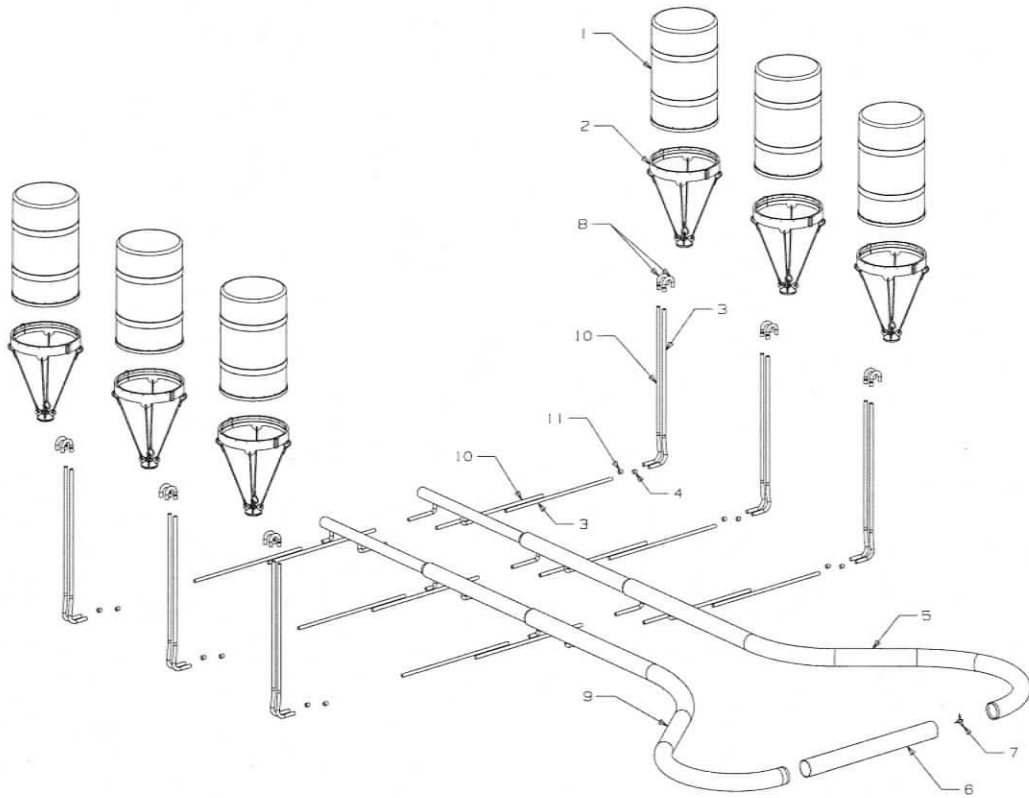

Figure 2.1: UFCAP Components; 1)air chamber, 2)mooring support, 3)supply conduit,4)supply check valve, 5)supply manifold, 6)central conduit, 7)turbine, 8)floating valves, 9)return manifold, 10)return conduit, and 11)return check valve.

to another air-chamber at a lower pressure. The velocity of the water particles does affect the pressure field. However, its contribution is small, specially at deeper waters since the velocity of the particles decreases exponentially with the depth [24]. The pressure field on the ocean is mainly controlled by the height of the water and can be approximated by [23]

$$P = \rho g z \quad (2.1)$$

where ρ is the water density, g is the gravity, and z is the water depth in meters. This means that, for a given location, the pressure below a crest is higher than the pressure below a trough.

It is important to point out that there is no air exchange between the system and the exterior. The same mass of air contained within the system is made to move from one air-chamber to another, back and forth. A turbine is placed in the middle of these flow to extract the energy from the generated airflow.

Even though the air is pumped in and out of the air-chambers in an oscillating manner, a unidirectional flow is accomplished by having two independent conduits per air-chamber, one to conduct the supply flow, and the other to conduct the return flow. Check valves placed on the conduits control the flow direction, allowing the air to flow only in the desired direction.

Hence, the six air-chambers (1)¹ feed the supply manifold (5) through conduits (3), and receive air from the return manifold (9) through the conduits (10). Accordingly, they all contribute to create an airflow in the direction of the arrow in Figure 2.2 that passes through the turbine (7). A detailed explanation of this behavior is given in the following section.

2.2 Components Description

The air-chamber (1) is a container with an opening at its bottom part. It is designed to trap air at its interior while allowing the surrounding water to go freely in and out through the bottom opening. Therefore, its interior is filled up with air and water. Every air-chamber is moored to the ground by the mooring-supports (2). In addition, for every air-chamber, there are two different set of conduits, called the supply-conduits (3), and the return-conduits (10) which connect the upper interior of the air chamber filled with air, with the manifolds, (5) and (9), respectively. Each conduit contains a floating valve (8) at its top end, which prevents the water intrusion to the conduits in case the water level increases above the height of the conduits.

¹Numerals within parenthesis in this chapter refer to the component number given on Figure 2.1.

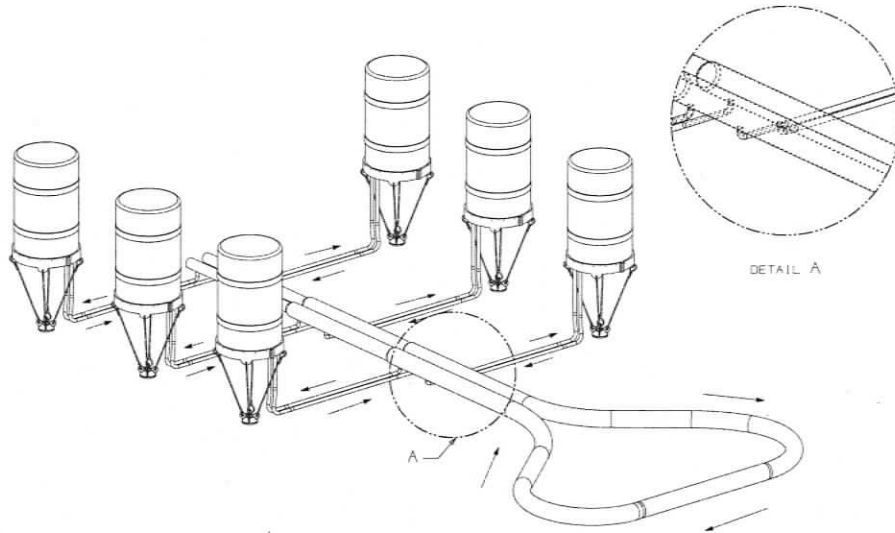

Figure 2.2: UFCAP in a 6 air chambers configuration.

This may happen if waves are higher than expected. Likewise, all supply conduits encompass a check valve (4) and return conduits a check valve (11). Both valves keep the flow unidirectional in such a way that conduit (3) only allows flow outward of the air-chamber, and the conduit (10) only allows flow into the air-chamber. The central conduit (6) is the part that connects the supply manifold (5) with the return manifold (9), and holds the turbine (7) inside.

2.3 Working Principle

The UFCAP operation consists in converting the energy from the ocean waves into a central airflow which is used to rotate a turbine. Air-chambers are the components that pump the air and create the airflow which rotates the turbine. The air-chamber is actually a cylinder where a “piston” slides inside to move the air in and out. However,

this mechanism does not have a piston component, it uses the water rising and falling as the piston.

As the air and water densities are very different, the boundary between the two fluids is well defined at all times. Being the water the element that pumps the air, it is possible to say that the device pumps the air with actually no-moving, or no-sliding parts. This is a very important attribute which makes UFCAP a simple and passive device with no-moving parts in contact with the ocean.

The pumping action is illustrated in Figures 2.3 and 2.4. The former illustrates the moment when a crest is above an air chamber. When this occurs, the hydrostatic pressure on the surroundings increases, which makes the water to flow through the bottom opening inward the air-chamber and rises the water level from the position (14b) to the position (14a). Such a rising causes the displacement of an equivalent volume of air outward the air-chamber. Valve (4) allows the flow outward the air chamber, while valve (11) does not. Therefore, the air is made to flow through the supply conduits (3).

Conversely, when the trough is above the air chamber (see Fig. 2.4) the pressure on the surroundings decreases, which causes the water level to decrease up to the position (14b). Under these circumstances, the supply valve (4) closes and the return valve (11) opens. Thus, the air is made to go through the return conduit (10) to fill the extra space inside the air-chamber.

2.3.1 Intermittency and Dimensionality

The rate at which the air is being pumped is a sinusoidal function of time. In other words, the air pumped by a single air chamber is intermittent. For instructive purposes only, imagine the wave pumping cycle divided into three stages depending on the action of the water: whether it is rising, it is static, or it is decreasing. These three stages are exemplified on Figure 2.5 by the zones *A*, *T* and *B* respectively. The zone

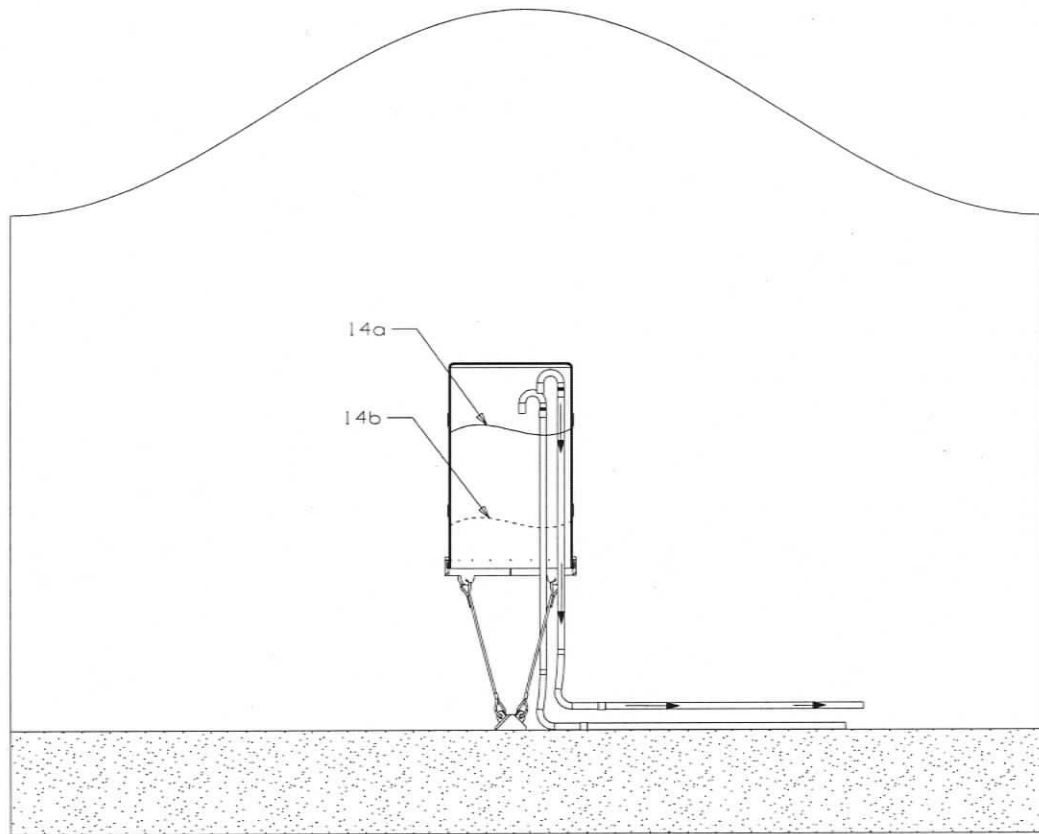

Figure 2.3: Supplying air

T is a transition zone, where no pumping is produced since the water level remains practically unchanged.

Nevertheless, the UFCAP system uses a plurality of air chambers which produce not an intermittent flow, but a “smoother” one. A more regular airflow is highly desirable since it improves the turbine efficiency.

Attenuation of intermittency takes place whenever the array length is longer than one ocean wavelength. When this happens, the air-chambers are pumping air at a different wave-phases. It means that, even though a few air-chambers are in the transition zone, there will be always other air-chambers pumping air, which partially eliminates the intermittency. The collective effect of all the air-chambers within an

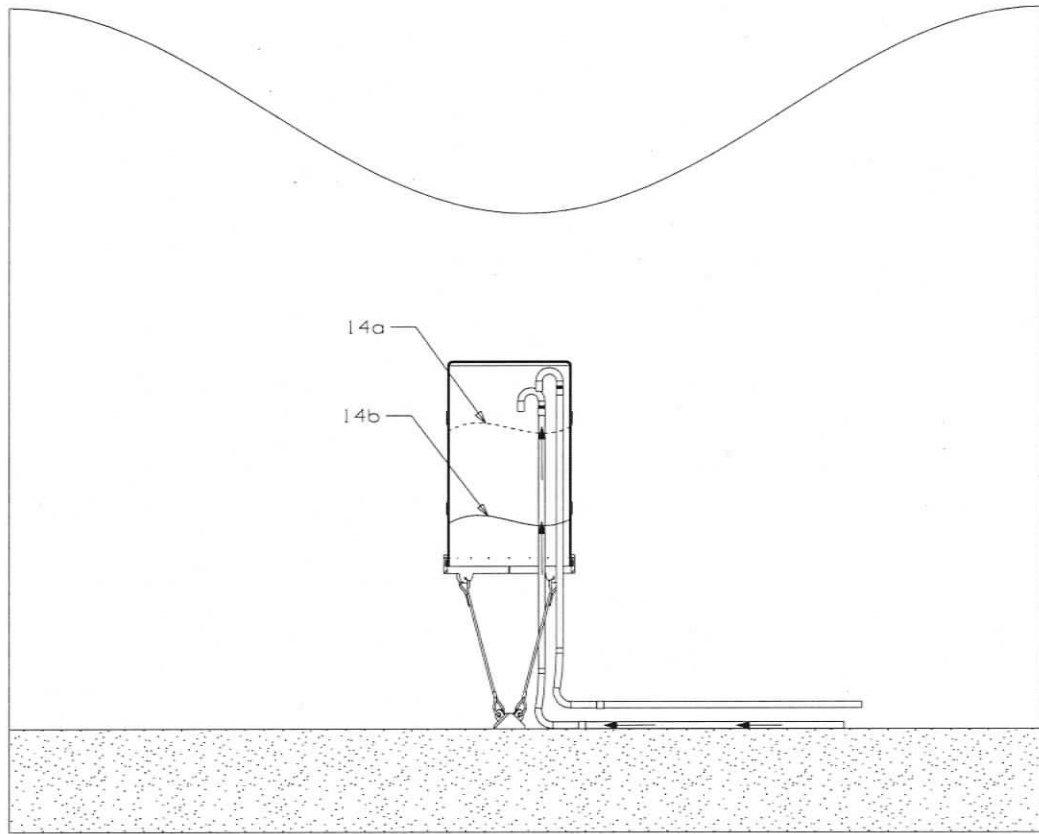

Figure 2.4: Returning air

array, creates a more constant, or less intermittent, airflow. The bigger the array in extension and in number of air-chambers, the lower the intermittency.

Figure 2.5 shows the top and front view of an array and an ocean wave above it. For the special case of a small array, it can be seen in the top view that while 3 air-chambers are in the zone *B* (pumping air inwards), there are 2 on the zone *A* (pumping air outwards), and 1 on zone *T* (in transition) for that specific instant in time.

On the issue of dimensionality, the array length is expected to be approximately at least twice the ocean wavelength. It is envisaged that the individual air chambers will be approximately 2 *m* in diameter and 4 *m* in height, which are small when

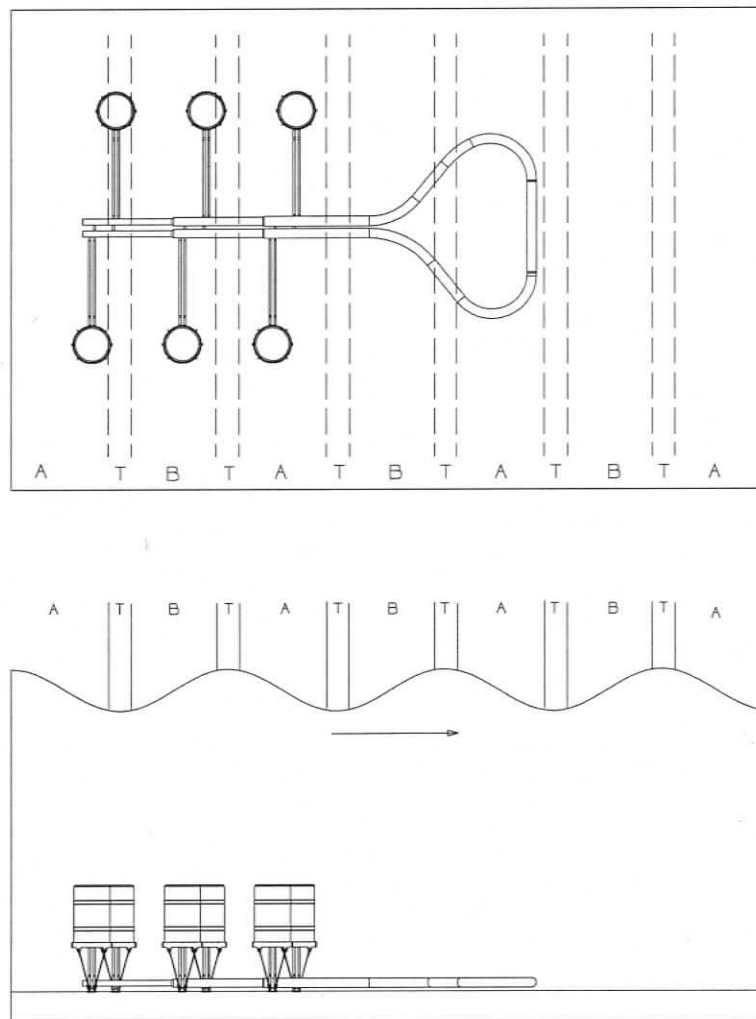

Figure 2.5: Air chambers at different pumping zones.

compared with the current WECs. Nevertheless, the nominal capacity (kW) of the system depends not only on the size of the individual air chambers, but also on the number of air-chambers which will determine the total volume of air displaced. As the proposed design is modular, the capacity could be increased or decreased as needed by adding or removing air chambers to the system.

Design parameters like spacing, size, array form, would be determined for a specific location and energy needs.

On the issue of modularity, it is possible to increase or decrease the device output

Table 2.1: Comparison Chart of Characteristics

Characteristic	UFCAP	Pelamis	AWS
Placed	Submerged	Floating	Submerged
Moving parts ^a	Null	4	1
Modularity	Modular	Non-modular	Non-modular
Larger Component [<i>m</i>]	2.5 x 2.5 x 3.5	3 x 3 x 40	9 x 9 x 30
Tuneability	Excellent	Good	Good
Impact of wavelength on efficiency ^b	Null ^c	Directly	Directly

^aMoving parts in contact with the water

^bNon-modular devices do perform optimum only for a given wavelength.

^cNull in a given range

capacity by adding or removing *modules*, in this case, the air-chambers. On the other hand, a *non-modular* device is that which is a complete and auto-sufficient apparatus by itself. Examples of it are the Pelamis, the Wave Dragon and basically all other WECs previously mentioned. To the best of the author's knowledge, all WECs to date except the proposed UFCAP are non-modular.

It is important to differentiate a farm of non-modular devices from a modular device. A farm is a group of devices, whether they are modular or non-modular.

Table 2.1 provides a summary of some of the features of 4 WEC.

2.4 Advantages

The main advantages of UFCAP can be summarized by the words **simplicity** and **modularity**. It is simple in several ways. The turbine and the check valves are the only moving components in the system. The rest of the components are completely passive. In addition, except the turbine, all the components are really simple and can be easily manufactured. However, unlike others WECs that use turbines, this turbine is unidirectional which is a lot simpler and cheaper than a Wells turbine.

Its modularity makes manufacturing, transportation, installation, and replacement much easier since it makes possible to handle small parts separately instead

of large and heavy components, such as in the case of available WECs. Same thing during maintenance, it is possible to float only the section to repair. The modular feature also provides flexibility with respect to the size of the system as it is possible to increase the array size when more power output is needed.

Incident ocean waves come in a variety of significant heights and periods. One of the most important parameters for a good performance of a WEC is the capacity of the device to rapidly tune up for the different waves. This capability allows WEC to extract the maximum amount of power from the incident waves [25]. However, the tuning-up is not perfect, and the efficiency is maximum only for a single combination of wave height and wave period. Then, it slightly drops as waves depart from the nominal value.

Conversely, because of its modularity feature, UFCAP do not need to be tuned-up for those isolated variations of wave height. Imagine an isolated peak “P” like the one on Figure 2.6. A non-modular device should rapidly tune up for the “new” wave height, and be re-tune up again to the previous configuration. In a modular device, the time available to make this change is longer. The time is not the wave period, but the time the wave takes to cross the whole array. Additionally, non-modular devices need to tune up from one wave to the next one which in some cases could be a big change. Modular devices, alleviate this change since the change is measured not from the pumping of one air chamber to another, but from the collective pumping of all the chambers in the array from one moment, to the next. This way, the device doesn’t need to be tuned up for local variations like the one showed on Figure 2.6.

Another important issue in the design of a wave device is the survivability. Submerged devices are safer and more desirable since the susceptibility to storms decrease exponentially with the depth of the water. Thus, **underwater** air-chambers and conduits are not expected to undergo large stresses because they are submerged and have no-moving parts. This is good in terms of cost since a device designed to support lower stresses is less expensive to manufacture. Additionally, submerged devices are

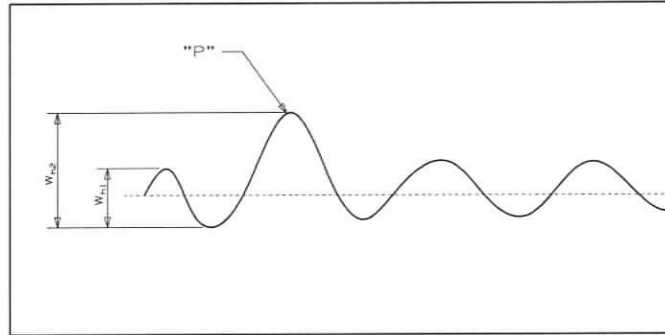

Figure 2.6: Ocean waves variability

more aesthetically pleasing and environmentally acceptable.

WECs need to get permissions from the governments in order to be placed at the ocean. Some grounds to deny permission include disturbance or destruction of marine life, possible threat to navigation from collisions and degradation of scenic ocean front view [14]. Here is where the **no-moving** parts and the underwater characteristics become important. The case of the city of San Francisco is one example of how important is this feature. San Francisco's citizens voted to approve \$100 million in bond financing renewable energy including tidal among other forms of green energy. After a careful analysis of all the tidal devices available up to that date, the authorities gave the contract to Hydro Venturi basically "(...) due to the value proposition of no-moving parts under water" [26].

Finally, applications are not limited to electricity generation. The turbine output can be also used for applications such as desalinization, water pumping or hydrogen-oxygen production among others.

2.5 Proof-of-Concept

Novel devices are required to prove that they work. Theoretical predictions are indicative but not sufficient. As there is not a similar apparatus to compare with, it was necessary to build a proof-of-concept laboratory experiment. Furthermore, numerical simulations were performed to simulate the air chamber action.

2.5.1 Experimental Setup

The experiment consisted in an array of two submerged air-chambers interconnected in a similar way as the real system. Figure 2.7 illustrate the experiment set up. Each air chamber embraced 2 conduits, and one check valve per conduit. Instead a turbine, a flow-meter was placed in order to quantify the amount of airflow produced.

The two air chambers were submerged into two independent water tanks. A mechanism to change the water height on each tank was designed in a way that it induced a maximum water height in one tank and a minimum on the second one. Being an array of only two air-chambers, the reduction of intermittency as explained in section 2.3.1 will not take place in this experiment. Thus, the experiment is not useful to perfectly mimic a full size device, which includes a plurality of air-chambers, but it is useful to provide an insight into the pumping mechanism.

The experiment does not mimic correctly the actual behavior of UFCAP since it only has two air chambers. For this reason, no technical data regarding the experiment would be provided here. However the experiment can effectively proof that the concept works. The experiment is then evaluated only qualitatively.

When the experiment was started, an airflow was observed in the expected direction. Also, the amount of airflow was larger during the equivalent *wave zones A* and *B* and almost null at zone *T* (see section 2.3.1), as expected. As only the qualitative behavior was evaluated, no more details are provided here.

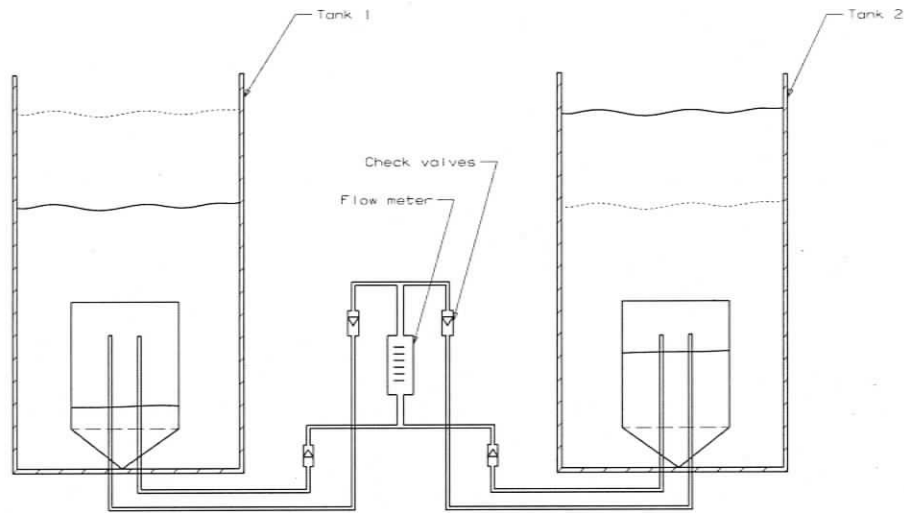

Figure 2.7: Experiment with two air chambers

2.5.2 Air Chamber Numerical Simulation

The second part of the proof-of-concept consisted of a numerical simulation of the air chamber which is the component where the two-phases (air and water) interact, and the one where the pumping takes place. Simulations using Fluent were carried out to better understand the phenomenon. Being a new component with no predecessors or previous data, this analysis is important in order to understand the flow behavior pattern in its interior, the amount of air pumped, the losses, or find out any unexpected situation if any. Additionally, it sets up a base for making future assumptions.

Problem Definition

The air chamber is basically an underwater container partially filled with air and water. It has three openings. One at the bottom that allows the water going in and

out of the air-chamber and pump the trapped air by this action, and two openings at the top part, one to supply air to the turbine, and one to return the air to the air-chamber. Each one of the two top openings has a check valve that must close and open automatically depending on the pressure at the interior of the air chamber for a given instant.

The only input to the system is the changing pressure imposed by the action of the ocean waves. Such a pressure, is the boundary condition to be applied to the bottom opening. The top two openings are subjected to an unknown pressure consequence of the collective effects of the air pumping of all the air chambers within the array.

Assumptions

A number of assumptions are needed for the numerical simulations:

1. Surface elevation η is assumed to be

$$\eta = a \cos(kx - \omega t), \quad (2.2)$$

which is the solution for progressive waves when infinite depth is assumed [24].

2. A wave height of 1.5m is assumed.
3. A 2D space is assumed because of computer resources restriction.
4. A laminar regime is assumed.
5. Ideal gas assumed
6. A depth of 25.4 m is assumed. At that depth and pressure conditions, the air density ρ_{air} is assumed to be 4.237 kg/m^3 and the kinematic viscosity ν $4\text{e-}06\text{m}^2/\text{s}$ [27].

Table 2.2: Summary of the Air-chamber's Models type

Model	Type
Solver	Segregated
Time	Unsteady
Formulation	Implicit
Space	2D
Multiphase	VOF (2 phases)
Viscous	Laminar

7. Salt water density ρ_w is assumed to be 1027 kg/m^3 . Salt water kinematic viscosity ν is assumed $1.003\text{e-}03 \text{ m}^2/\text{s}$.
8. Pressure at the outlet P_R and P_S assumed to be constant and 0 pascal. ²
9. Check valves are assumed to open and close exactly at the nodal points. ³
10. Null pressure drop due to check valves is assumed.

Numerical Simulation

Table 2.2 summarizes the characteristics of the numerical simulation. The Volume of Fluid (VOF) is a two-phase model which requires the boundary between the two phases is well defined at all times.

The geometry was meshed using a structured grid shown in Figures 2.8 and 2.9. It has 16,238 cells and 16,529 nodes. To evaluate mesh independence, a finer structured mesh was also used.

Table 2.3 summarizes the values used for all the properties.

Segregated solvers solve the equations sequentially. It was chosen for the present analysis because it is appropriate for incompressible and mildly compressible flows [28].

²At this point, they are unknown and can not be computed using a single air chamber. In the next chapter they are computed and it was found out that their values are in the order of 3kPa .

³A few trials were done where the check valves open and close freely as a consequence of the pressure variations. Deviations from the nodal points were found to be negligible.

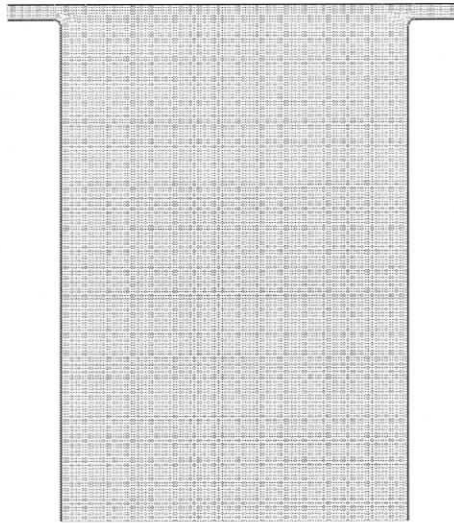

Grid (Time=5.1750e+01) Jun 26, 2006
FLUENT 6.1 (2d, segregated, vof, lam, unsteady)

Figure 2.8: Air Chamber's geometry

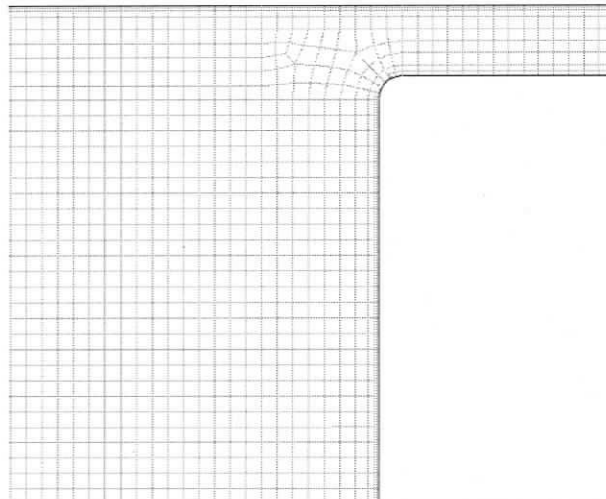

Grid (Time=5.1750e+01) Jun 26, 2006
FLUENT 6.1 (2d, segregated, vof, lam, unsteady)

Figure 2.9: Air Chamber's mesh

Table 2.3: Property Values

Property	Value
ρ_{air} at 25.4 m depth	4.237 kg/m ³
ρ_w salted water	1027 kg/m ³
Gravity g	9.81 m/s ²
Pressure inlet	7344 + 3427cos($\pi/2 - 0.6981317t$)
Pressure outlet	0 Pa

Fluent has several predetermined boundary conditions (BC). This simulation required three types. A *wall* BC was applied all over the walls of the air chamber. A *pressure inlet* BC was applied to the bottom opening, and a *pressure outlet* BC was used in the top openings.

The pressure at the bottom opening is a function of time defined by:

$$P = C + a_p \cos(\pi/2 - \omega t), \quad (2.3)$$

where C is a constant to compensate the water weight, a_p is the amplitude of the pressure variation, ω is the circular frequency, and t the time.

Fluent does not accept this kind of inputs directly. It is necessary to create a User Defined Function (UDF) to define equation 2.3 (see Appendix A).

Results

The objective of this analysis is to complement the experiment explained above and fully prove that an airflow is created by an air-chamber with characteristics as those described in this thesis. Figure 2.10 demonstrates the mass flow rate in time. The first cycle is initialized with velocities equal to zero. Three subsequent cycles are necessary to obtain results independent of the previous cycle. It coincides with other studies which employ numerical methods on cyclic devices [29]. No unexpected behaviors were observed.

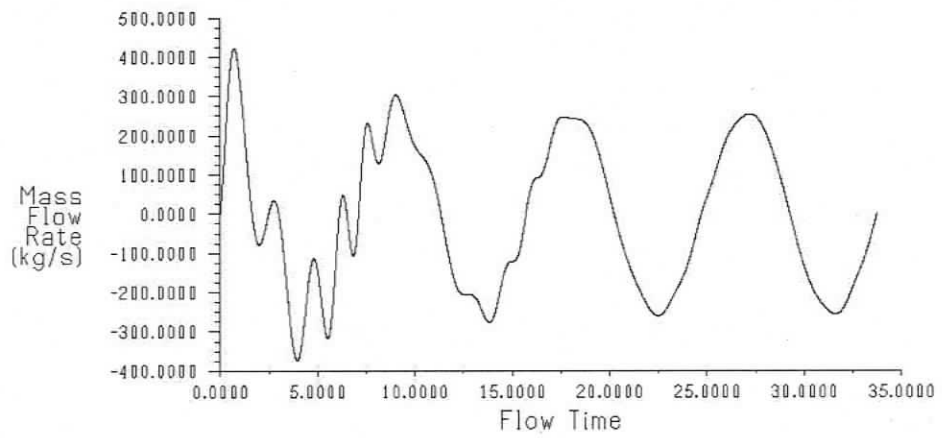

Convergence history of Mass Flow Rate on pressure_inlet.2 (Time=3.3750e+01) Mar 20, 2006
FLUENT 6.1 (2d, segregated, vof, lam, unsteady)

Figure 2.10: Water mass flow rate on "Pressure Inlet."

Chapter 3

Performance Evaluation of the Device

In this chapter, the performance of the UFCAP is predicted analytically. The analysis aims to predict the overall performance based on a simplified flow analysis. The main purpose of this chapter is to predict the power available in the airflow as well as to design and size an appropriate UFCAP system for the weather conditions at Vancouver Island. The values of the design parameters are determined using a parametric analysis process.

3.1 Assumptions

In order to compute the amount of airflow produced and the power available in the airflow, the following assumptions are made:

1. Laminar flow.
2. Losses due to friction are negligible.

3. Steady flow; physically, it means the array is large and the wave pattern is constant.
4. Flat velocity profile across conduits.
5. Check valves pressure drop ΔP_{ck} equal to 150 Pa. See section 4.2.1.

3.2 Analysis

As explained on Chapter 2, the sole input to the system is a pressure $P(t)$ imposed by the ocean waves to a number of air chambers. The maximum pressure gradient produced by an ocean wave of amplitude a_w is equal to

$$P_{w_2} - P_{w_1} = \rho_{water}g(2a_w). \quad (3.1)$$

However, the amplitude of the water level variation inside the air chamber a_{ch} is not the same as a_w (see Figure 3.1). a_{ch} is *unknown* and its calculation requires further analysis. The same way, there is a pressure gradient $(P_{w_2} - P_R) - (P_{w_1} - P_S)$ proportional to a_{ch} given by

$$(P_{w_2} - P_R) - (P_{w_1} - P_S) = \rho_{water}g(2a_{ch}), \quad (3.2)$$

where P_R is the pressure at the end of the return conduit, and P_S is the pressure at the end of the supply conduit. Figure 3.2 exposes the equivalence between the amplitudes and the pressures involved with the air chamber.

The power output of the device can be computed once the volumetric flow at the central conduit has been calculated. The volumetric flow Φ would be the volume of air displaced by the rising and falling of the water level at the interior of the air

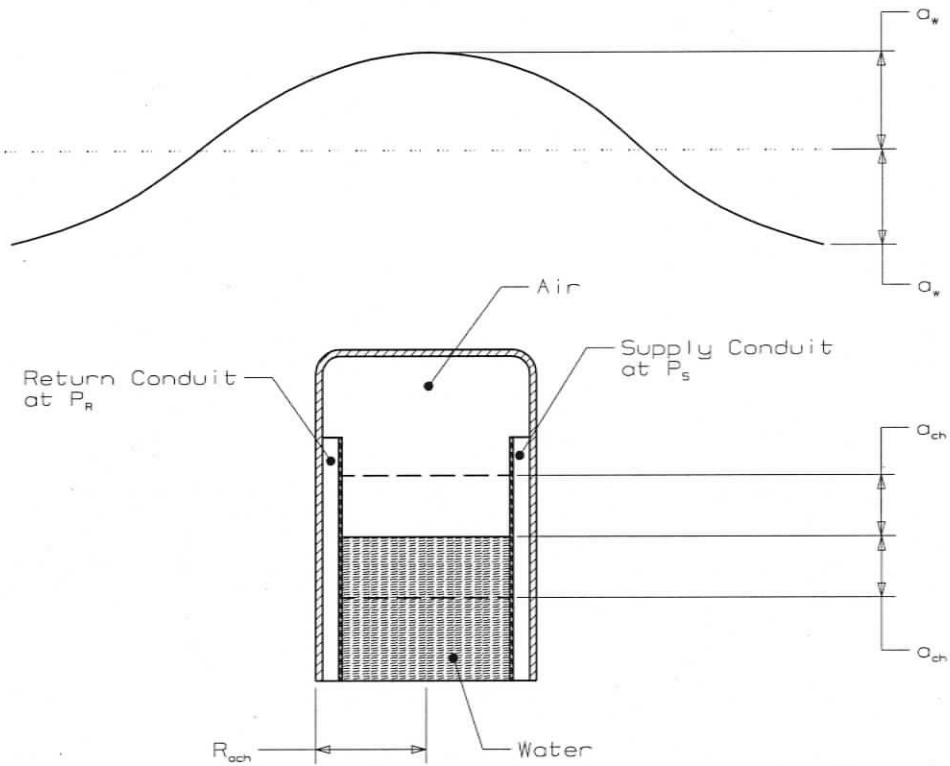

Figure 3.1: Wave effect inside the air chamber.

chamber and is defined in terms of a_{ch} as

$$\Phi = NA_{ch} \frac{4a_{ch}}{T}, \quad (3.3)$$

where N is the number of air-chambers, A_{ch} is the area of the cross section of the air-chamber, T is the period of the wave, and a_{ch} is the amplitude of the water level variation.

Separate the apparatus into three domains: one include the air chambers, domain U , one including the conduits and part of the manifolds, domain K , and one including the other part of the manifolds and the central conduit, domain S (see Figure 3.3). Focus on domain U . The value of a_{ch} determines the amount of airflow Φ produced (Eq. 3.3) and at the same time set up the pressures P_R and P_S (Eq. 3.2). Assume

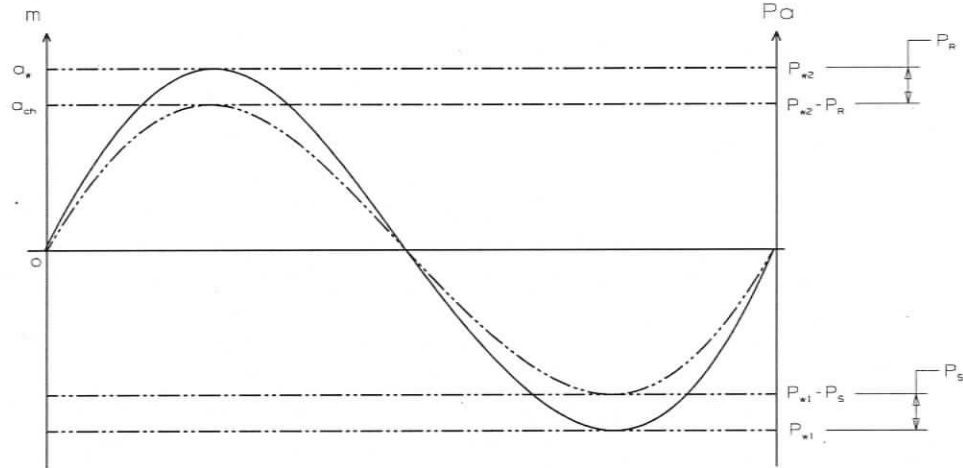

Figure 3.2: Equivalence between amplitude and pressures.

a constant pressure in all the pipelines on domain K . Then, all supply conduits on domain K (the shaded ones) are at a constant pressure P_S and all the return conduits on domain K (non-shaded ones) are at a constant pressure P_R .

The pipeline in domain S , is simplified into a straight pipeline with a turbine in its interior (see figure 3.4). The flow Φ across pipes can be computed using Poiseuille's formula

$$\Phi = \frac{\pi \Delta P_{eff}}{8 \mu_{air} \Delta x} R_{cent}^4 \quad (3.4)$$

if the pressure gradient ΔP_{eff} , the radius of the central conduit R_{cent} , and the conduits' length Δx , are known.

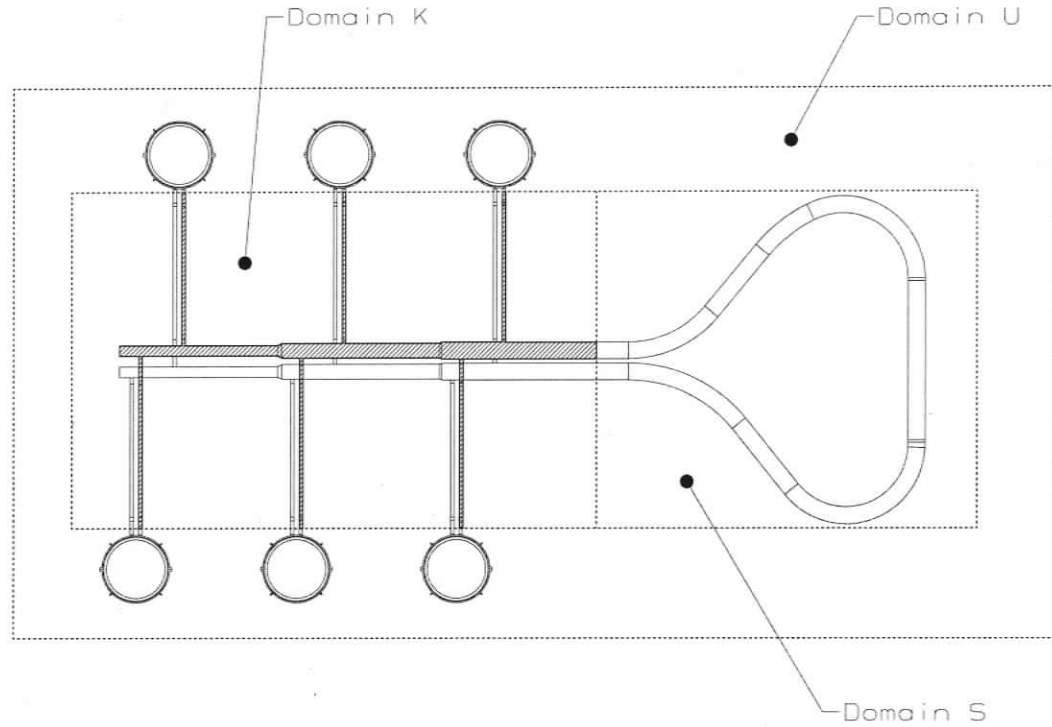

Figure 3.3: UFCAP divided in domains.

3.2.1 Pressure Drop

The maximum pressure gradient available in the system is given by

$$\Delta P_{available} = (P_{w_2} - P_R) - (P_{w_1} - P_S). \quad (3.5)$$

However, the effective pressure gradient ΔP_{eff} used in Poiseuille's formula is different. The pressure drop due to the turbine and check valves, should be included.

Therefore, ΔP_{eff} is described by

$$\Delta P_{eff} = \Delta P_{available} - \Delta P_{losses} \quad (3.6)$$

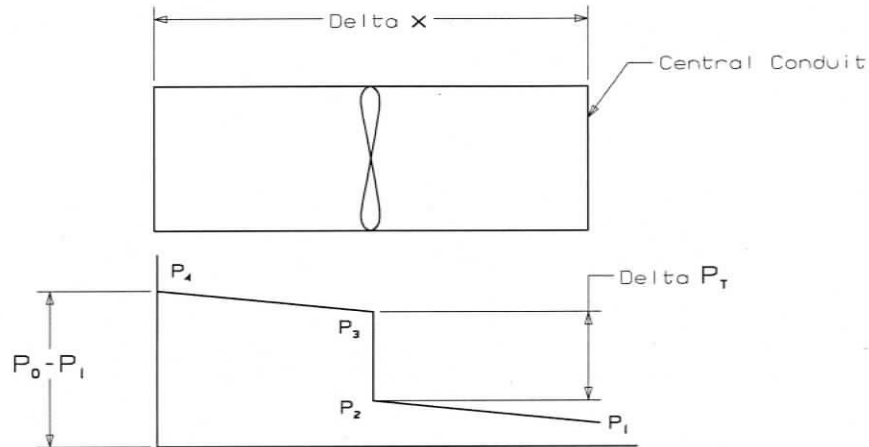
Figure 3.4: Central Conduit ΔP_T .

with

$$\Delta P_{losses} = 2\Delta P_{ck} + \Delta P_T, \quad (3.7)$$

where ΔP_{ck} is the pressure drop due to a check valve, and ΔP_T is the pressure drop due to the turbine.

The value of ΔP_{ck} is assumed independent of the flow magnitude. Conversely, ΔP_T depends on the flow which is still unknown.

Pressure Drop Across the Wind Turbine

Using a turbine to extract energy from an airflow inside a pipe is not a common application at all, specially at the low pressure gradients that the UFCAP operates. Several types of turbines were studied in order to identify the one that better suits UFCAP's requirements. Wind turbines were selected as the best alternative (see section 4.3 for more details).

However, wind turbines operate externally, not inside a pipeline. Therefore, some modifications to wind turbine theory are needed in order to compute the ΔP_T for a wind turbine inside a pipeline.

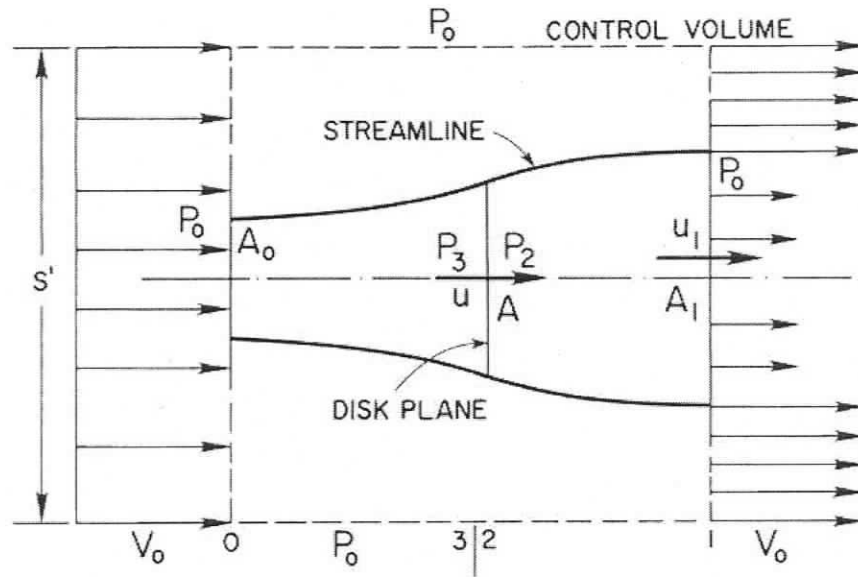

Figure 3.5: Flow pattern on a “exterior” wind turbine [30]

In an exterior wind turbine, the flow is slowed down while it passes through it. That is, the streamline is forced to expand to account for mass conservation (see figure 3.5).

The static pressure first increases up to P_3 just before reaching the rotor, then decreases to P_2 , and finally increase until P_0 (see figure 3.6 (d)).

In a “pipelined wind turbine”, there is not a slow down of the airflow. That means the flow velocity $V_0 = V_1$. Thus, the energy transmitted to the turbine is only due to the pressure drop across it. Another difference with exterior wind turbines is that $P_0 = P_3$ and $P_1 = P_2$. The pressure become constant, get reduced across the turbine and then keeps constant (see figure 3.7).

Defining the velocity u as the velocity of the flow right next to the rotor. The

Bernoulli's equations for the exterior turbine are

$$\frac{1}{2}\rho V_0^2 + P_0 = \frac{1}{2}\rho u^2 + P_3 \quad (3.8)$$

$$\frac{1}{2}\rho u^2 + P_2 = \frac{1}{2}\rho u_1^2 + P_0, \quad (3.9)$$

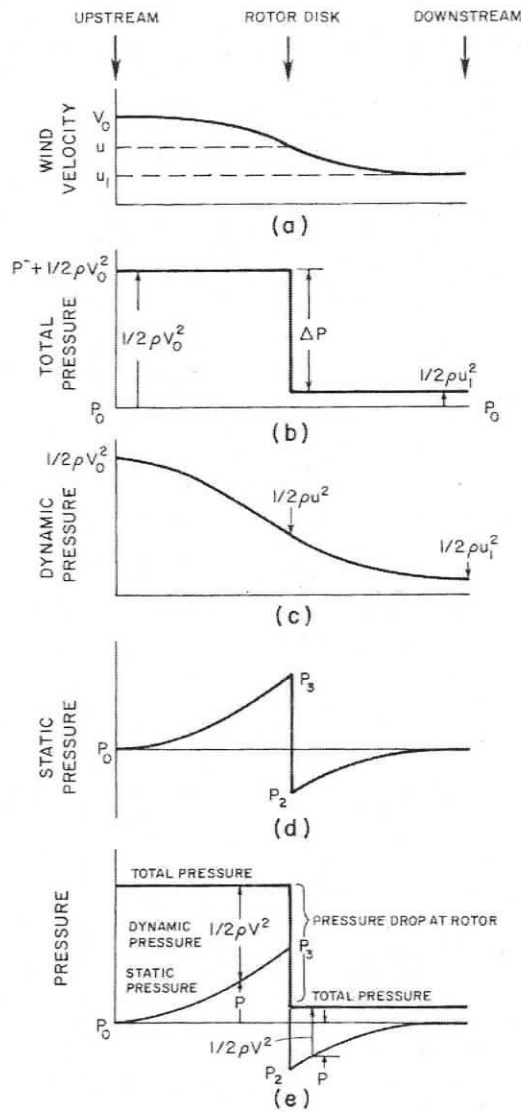

Figure 3.6: Pressure relations on a "exterior" wind turbine [30].

Assuming $P_3 - P_2$ is the same for either an exterior wind turbine or a pipeline

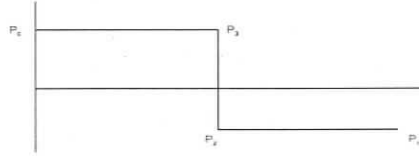

Figure 3.7: Static Pressure on Central Conduit

wind turbine. Assuming that both turbines run at maximum efficiency, at $V_0 = 3u_1$, and that $u = \frac{u_1 + V_0}{2}$ [31].

Define ΔP_T and Φ as

$$\Delta P_T = P_3 - P_2 \quad (3.10)$$

$$\Phi = \bar{V} A \quad (3.11)$$

where \bar{V} is the average velocity. Neglect the boundary layer effects and assume that the velocity \bar{V} is constant and equal to u . By solving the Equations 3.8, 3.9, 3.10 and 3.11 it is found

$$\Delta P_T = \frac{17}{8} \frac{\Phi^2}{\pi^2 R_{cent}^4} \quad (3.12)$$

with R_{cent} being the central conduit's radius.

Having calculated ΔP_T and ΔP_{eff} , it is possible to solve the equations. They are solved for Φ in order to further compute the power available in the airflow. An iterative method was used for convenience in where the two flows of domains U and S were made to converge by setting up an appropriate value of a_{ch} .

In general, the variation imposed by an ocean wave of amplitude a_w would produce a smaller variation a_{ch} determined by the relative densities and the pressures P_S and P_R .

In the previous analysis, it was assumed that the array is big enough to neglect the intermittency effects on the flow, however a further analysis about the susceptibility of the number of air chambers should be carried out.

3.2.2 Parametric Analysis

The objective of the following analysis is to determine a combination of parameters that generates more power for the particular ocean waves in Vancouver Island.

The distribution of ocean waves in Vancouver Island is presented on figure 3.8. The data is taken from Environment Canada's buoy 46206 moored at La Perouse Bank. It is located Southwest of Ucluelet and Amphitrite Point with coordinates $48^{\circ} 50' 2'' N$, $126^{\circ} 0' 0'' W$.

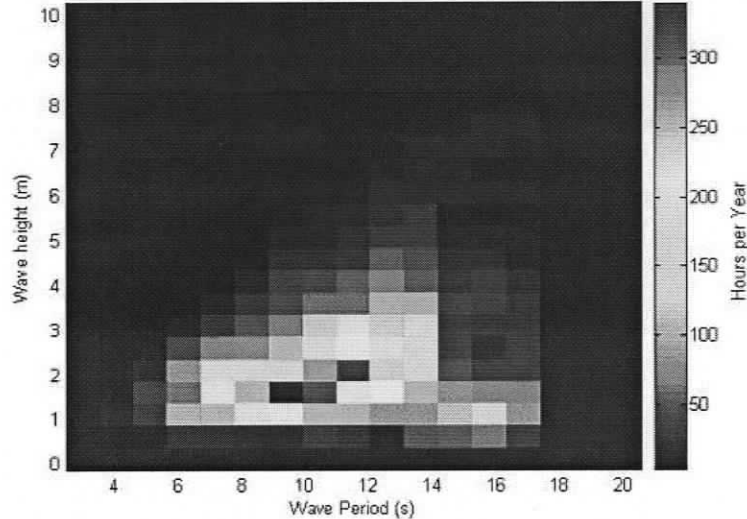

Figure 3.8: Wave climate for La Perouse Bank buoy, 2003 [32]

Given this conditions, the aim is an apparatus which behaves optimum for wave periods between 8-13 *sec* and wave heights between 1-3 *m*.

Design Parameters

The parameters are broken down into two categories: the fixed parameters and the free parameters.

The value of the fixed parameters used to produce the following graphics are shown in Table 3.1. In order to be able to fix them, it is assumed that all cases operate at a depth of 25.4 *m* which determines the values of air density and viscosity. In addition, it was observed that variations on Δx had a negligible impact on P_w .

Table 3.1: Value of the Fixed Parameters.

Parameter	Value
$\Delta x [m]$	120
$\rho_{air} [kg/m^3]$	4.2
$\nu_{air} [m^2/s]$	$4e^{-6}$
$\rho_w [kg/m^3]$	1027
$\Delta P_{ch} [Pa]$	1500

Conversely, the three *design parameters* with the largest impact on the performance were chosen as free parameters for the analysis. The order in which the parameters were examined is presented below:

1. R_{cent} = Radius central conduit.
2. N = number of air chambers.
3. R_{ch} = Radius air chamber.

Performance Criteria

To assist in the selection of the design parameters, a performance criteria is established as the power available in the airflow, being the larger the power, the better the system. It is defined by

$$P_w = \frac{1}{2} \rho_{air} (\pi R_{cent}^2) V_{air}^3 \quad (3.13)$$

where V_{air} is the average velocity of the airflow and is computed from Φ .

Radius Central Conduit

The most sensible variable is the Radius of the Central Conduit. To study the R_{cent} all other parameters were fixed to an initial guess of $N = 55$, and $R_{ch} = 1.2 \text{ m}$. The R_{cent} was varied from 0.8 m to 1.4 m with increments of 0.1 m .

The power available on the airflow is showed in Figures 3.9 to 3.14 for a variety of wave heights and wave periods.

The design goal of the system points towards a maximum power in the desired range of wave lengths and wave periods. From the graphics, it is observed that the smaller the R_{cent} , the larger the P_w . The conclusion is to keep R_{cent} as small as possible. However, a zone of inoperability is observed for small values of R_{cent} . This zone means that the pressure necessary to generate the flow required to satisfy La Poiseuille formula, is smaller than the pressure ΔP_{eff} available in the system.

A value of 1.0 m is chosen for R_{cent} since the system is at a maximum and operable for all combinations of wave heights and wave periods between $1\text{-}3 \text{ m}$ and $8\text{-}13 \text{ sec}$ respectively.

In more detail, reducing the diameter of the central conduit has two effects. First, it decreases the ΔP_{eff} which slightly decreases the airflow. This only effect would reduce the volumetric flow and then, the power available. However, reducing the diameter of the central conduit also increases the velocity of the airflow. Therefore, the net result is an increment in the net power output, because the power is proportional to the third power of the velocity. Nevertheless the value of the diameter of the central conduit can be reduced only to a minimum allowable and nothing more. Passing this minimum would cause the system to operate improperly diminishing its efficiency.

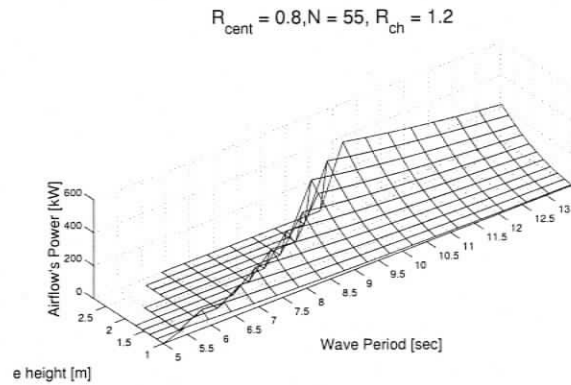
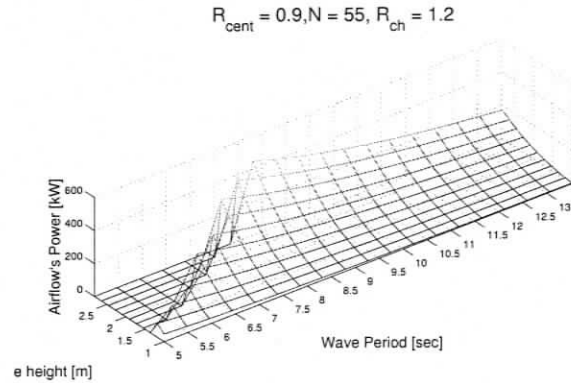
Figure 3.9: Power Available in the airflow at different R_{cent} .Figure 3.10: Power Available in the airflow at different R_{cent} .

Number of Air Chambers

The next parameter considered is the number of air chambers. The procedure is the same. The other two parameters are fixed and equal to $R_{cent} = 1.0$, $R_{ch} = 1.2$, and N is varied from $N=35$ to $N=85$ in increments of 10. Increasing the number of air chambers favorably increases the power available in the airflow. However, there is also an upper limit of operability. A value of $N = 65$ is chosen since it gives a maximum power for all combinations of desired waveheights and periods.

The number of air-chambers has also a direct impact on the intermittency issue, being the larger the number of air chambers, the less the intermittency.

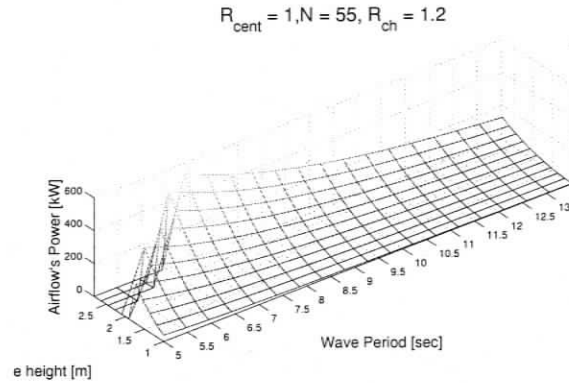
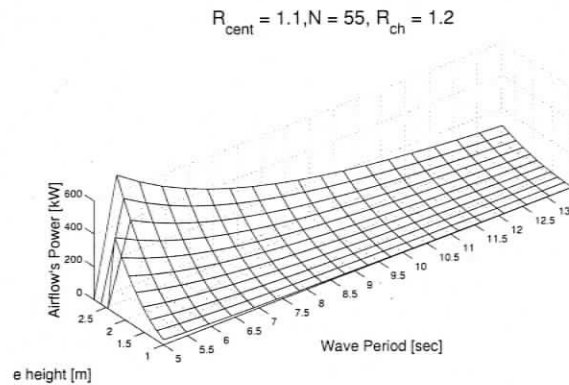
Figure 3.11: Power Available in the airflow at different R_{cent} .Figure 3.12: Power Available in the airflow at different R_{cent} .

Radius of Air Chambers

Increasing the radius of the air chamber, increases the volume of air to be pumped. Then, it is expected that the larger the R_{ch} , the larger the power is. That can be seen in Figures 3.21 to 3.26. In this case, R_{cent} is made equal to 1.0 and N equal to 65. R_{ch} is varied from 0.9 to 1.4 m in increments of 0.1 m.

A value of $R_{cent} = 1.2$ is chosen for giving the maximum power for the wave heights and periods of interest.

It is important also to note that the dimensions on the air-chamber impact not only the power available in the flow, but also the cost of the system. Then, special considerations should be taken to decide the size of the air-chambers.

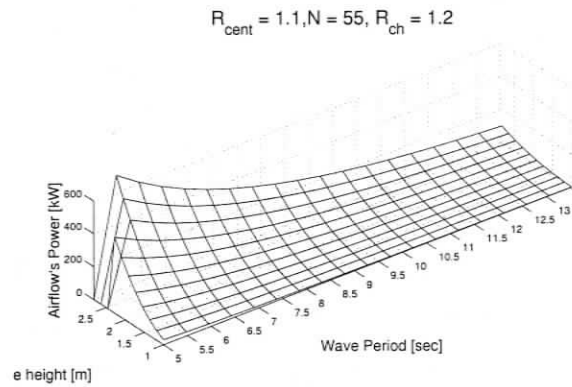
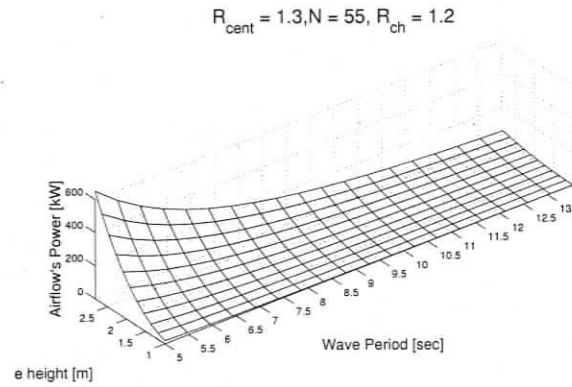
Figure 3.13: Power Available in the airflow at different R_{cent} .Figure 3.14: Power Available in the airflow at different R_{cent} .

Final Design

Summarizing, the value of the design parameters were selected for a system which operates desirably off the coast of Vancouver Island. These values are to be used to build the UFCAP system shown on Chapter 4.

The value of the design parameters for the final design are summarized in Table 3.2.

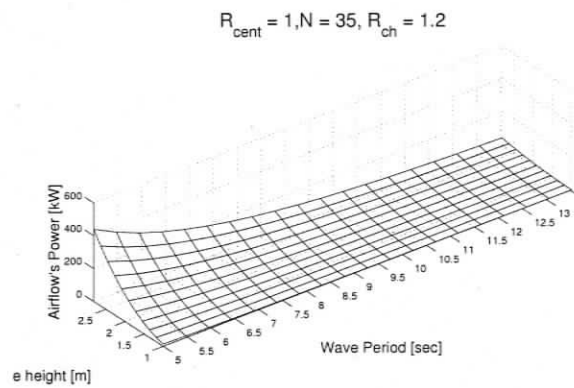

Figure 3.15: Power Available in the airflow at different N .

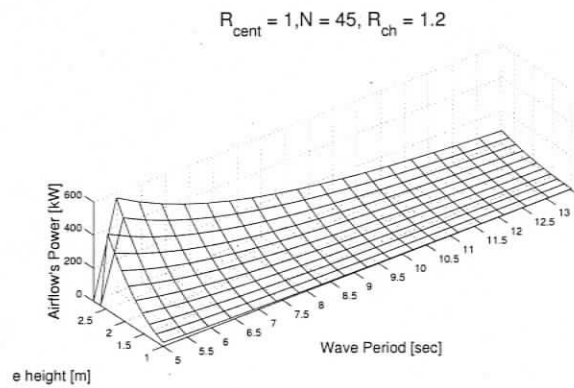

Figure 3.16: Power Available in the airflow at different N .

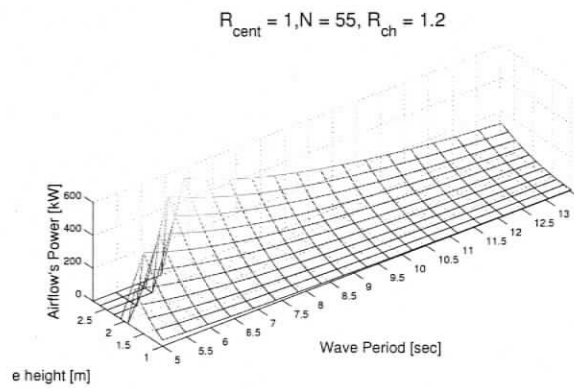

Figure 3.17: Power Available in the airflow at different N .

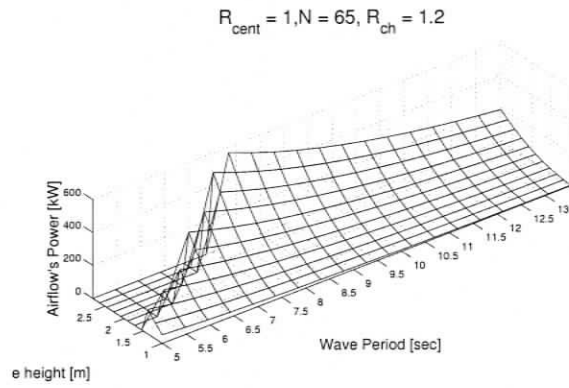

Figure 3.18: Power Available in the airflow at different N .

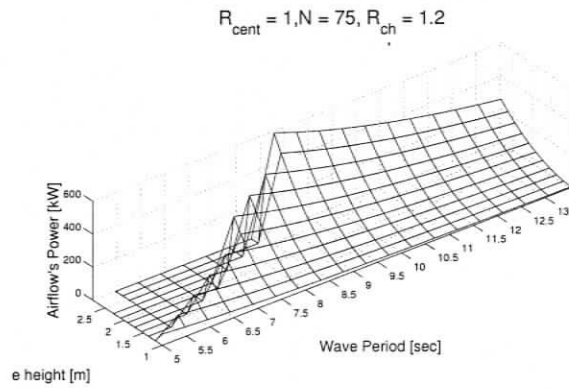

Figure 3.19: Power Available in the airflow at different N .

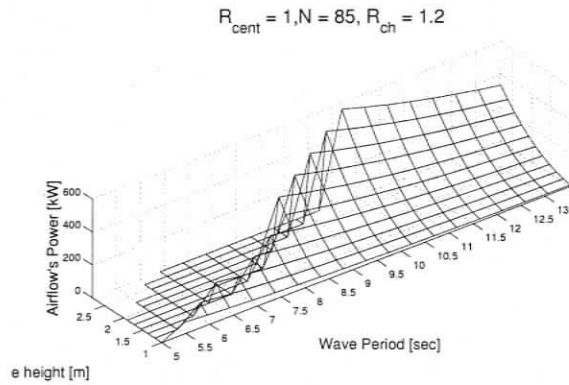

Figure 3.20: Power Available in the airflow at different N .

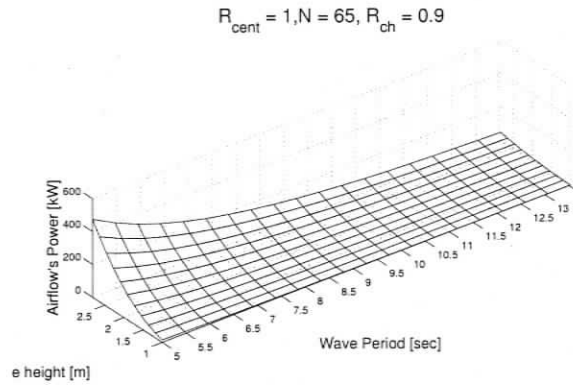

Figure 3.21: Power Available in the airflow at different R_{ch} .

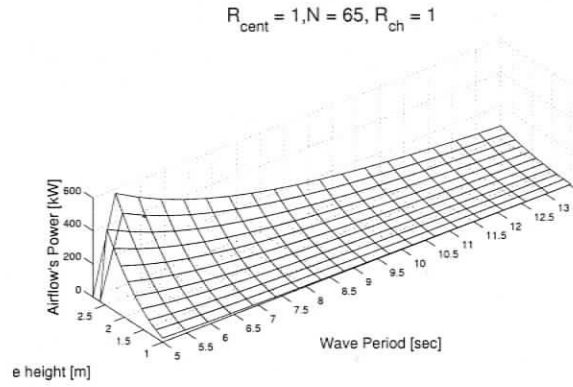

Figure 3.22: Power Available in the airflow at different R_{ch} .

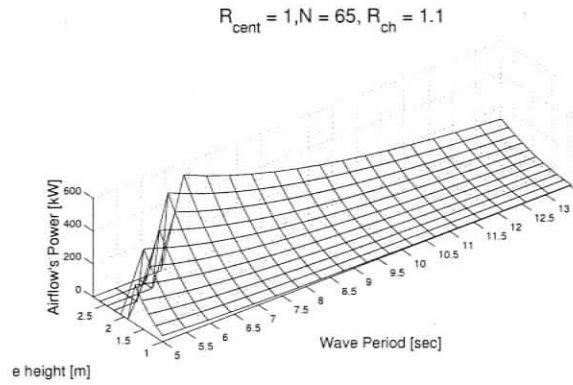

Figure 3.23: Power Available in the airflow at different R_{ch} .

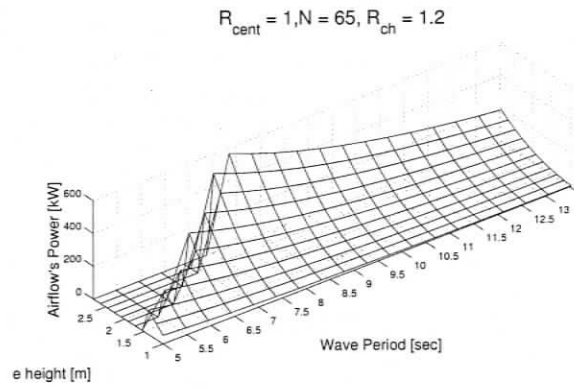

Figure 3.24: Power Available in the airflow at different R_{ch} .

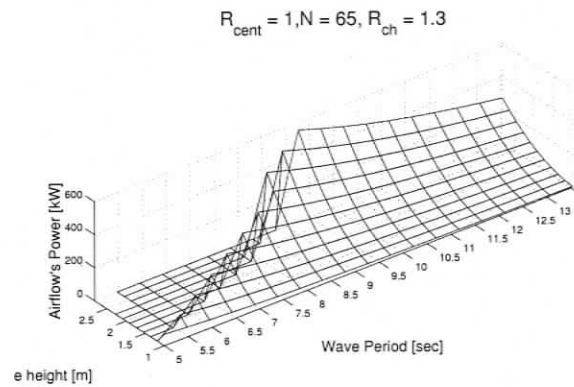

Figure 3.25: Power Available in the airflow at different R_{ch} .

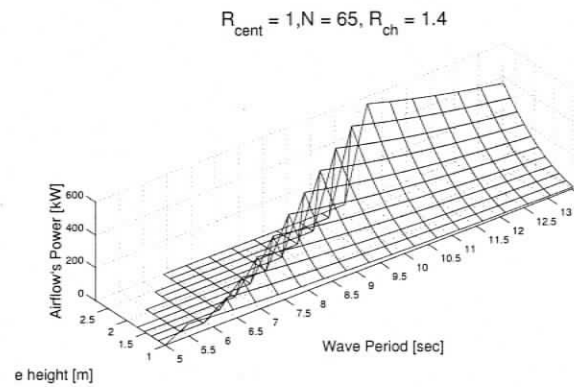

Figure 3.26: Power Available in the airflow at different R_{ch} .

Table 3.2: Parameter's Value of the Final Design.

Parameter	Value
$R_{cent}[m]$	1.0
N	65
$R_{ch}[m]$	1.2
Wave heights $[m]$	1 - 3
Wave periods sec	8 - 13

Chapter 4

Technical Data

This chapter presents the technical data of the main components of the proposed UFCAP system. In the case of customized components, such as the air-chamber, the technical data refers to drawings where the characteristic dimensions are specified. In the case of of-the-shelf commercial components, such as the check valves, the technical data refers to the supplier's information.

4.1 Mooring Supports

The objective of this component is to hold an air-chamber to the ocean floor. Keeping in mind the design requirements of simplicity and cost, a tethered support was selected. The number of the tethers would be determined once the structural design have been completed. Since this is not part of the present thesis, it will not be defined.

With this tethered approach, the stresses due to moments are suppressed, remaining only the stresses due to the tension forces. The drawing P/N 10-003 at the end of the chapter depicts the concept.

4.2 Air Chamber

Since the air-chamber is a passive component, it is not subjected to any force other than the bouyancy force. Since no special requiremtns due to high stresses are needed, one inexpensive possibility is to use a material and manufacturing technique similar to those used in industrial watertanks [33].

4.2.1 Check Valves

Check valves are valves that allow flow only in one direction. They are readily available in the market in a wide range of sizes and models. This design requires a check valve with the lowest pressure drop possible which at the same time ensures a unidirectional flow. The selected check valve is a CKS 2 inches diameter. The specifications can be found in Figure B.1 at the Appendix A.

4.2.2 Conduits

Conduits, unions, fittings, flanges, and flange adaptors, are also readily available in a wide range of options [34]. Even though the surrounding pressure is around 2 atmospheres, the internal pressure is almost the same. Thus a pressure pipe is not required. As the main design constrains are the cost and the corrosion, a PVC piping results appropriated. A sample of the products can be seen in Figure 4.1.

4.3 Turbine

There are many applications where a turbine is used to extract the energy from a fluid-flow. The most common turbines are gas-turbines, steam-turbines, water turbines and wind-turbines.

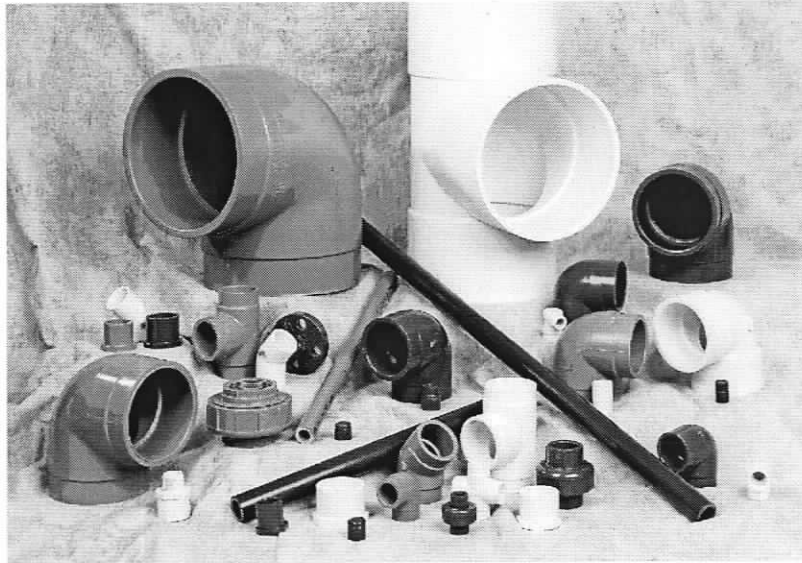

Figure 4.1: Pipe fitting from Georg Fishers Piping Systems [34].

Most of the applications where turbines are used, involve very large pressure gradients and sometimes high temperatures, like in the case of gas-turbines or steam-turbines. Conversely, a turbine to extract energy from a flow with a very small pressure gradient, it is not a common application. David's turbine is an example of a turbine which is able to operate under very low pressure gradients, however it requires that the operating fluid has a higher density than air [35].

The only example of turbines that use a low pressure airflow are those kind of turbines used in the OWC devices [36] [37]. Most of the OWC use a turbine called Wells turbine after his inventor. This turbine accepts an oscillating flow and is able to work with very low pressure gradients.

In UFCAP, a unidirectional airflow is generated versus an oscillating flow. Then, there is no gain in using a Wells turbine which is more complex and less efficient [38] if a simpler turbine can be used.

Water turbines like Francis, Pelton and Kaplan are also not appropriate for UFCAP since the application requires a turbine which deals with large flows and small pressure gradients, which suggest a short blade turbine. The most suitable turbine is

therefore a wind turbine.

Wind turbines can extract the energy of an airflow at a very low pressure gradients [39] and they are a lot simpler than a Wells turbine. In addition, wind turbines are a technology which is readily available in the market in all sizes.

Selecting a commercial wind turbine also facilitates the design process. There are several models which already include a pitch mechanism, which is a mechanism to rotate the blades to account for different wind speeds. Then, there is no need to design a further tuning mechanism for the UFCAP. This simplifies the UFCAP design.

The maximum power coefficient for wind turbines is called the *Betz coefficient* and is equal to 0.593. However this number is computed from an incident tube of air of smaller area than the wind turbine. The corresponding power coefficient of an ideal turbine using the original tube of air is $8/9$, and this is an important remark that should be taken into account during computations for a *pipelined wind turbine*.

Having the airflow confined within a pipeline instead in exterior, it is possible to manipulate the flow to increase the wind speed and decrease the size of the rotor. Such a manipulation would allow to reduce the cost of the wind turbine. However, a customized wind turbine should be requested from the suppliers to operate on this special flow characteristics.

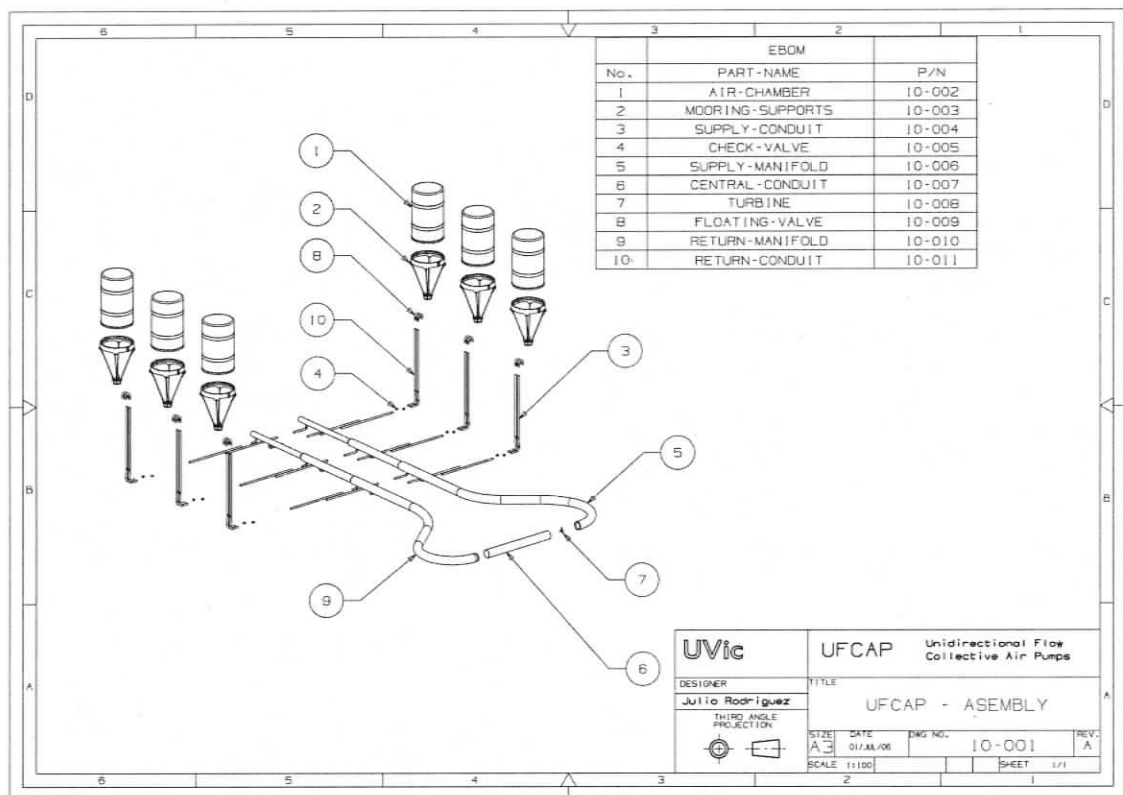

Figure 4.2: UFCAP-Assembly

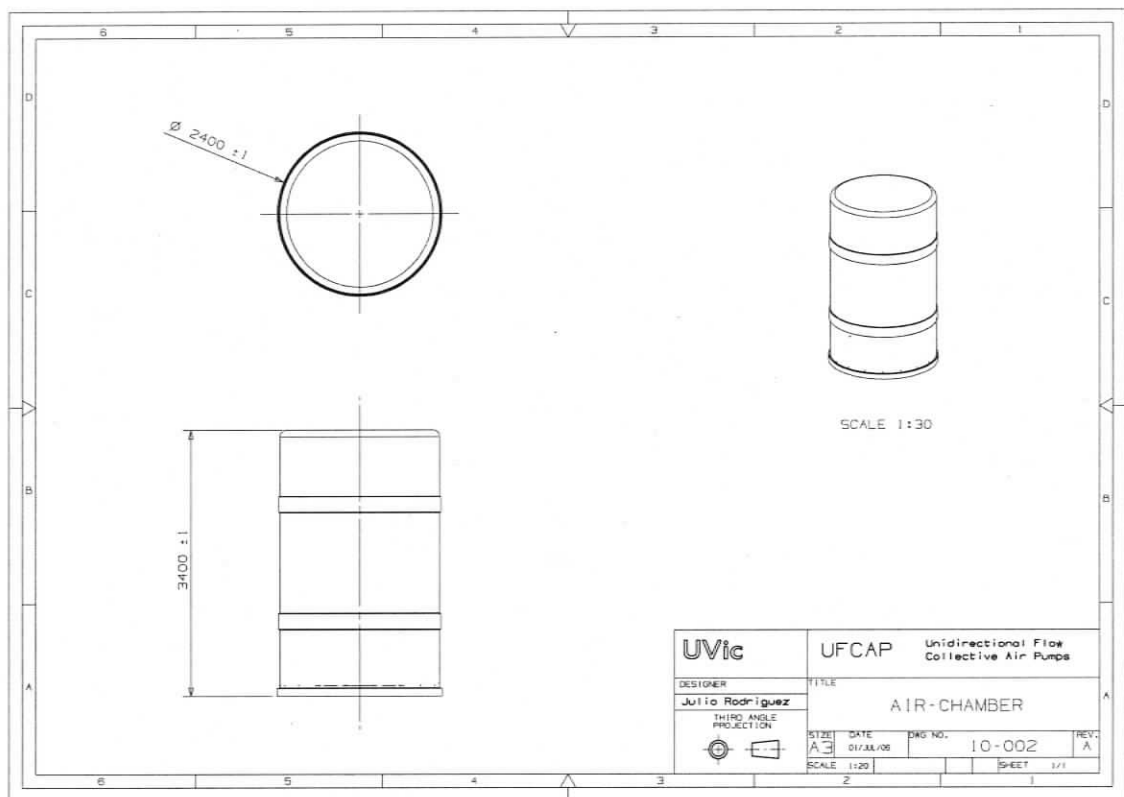

Figure 4.3: Air-chamber

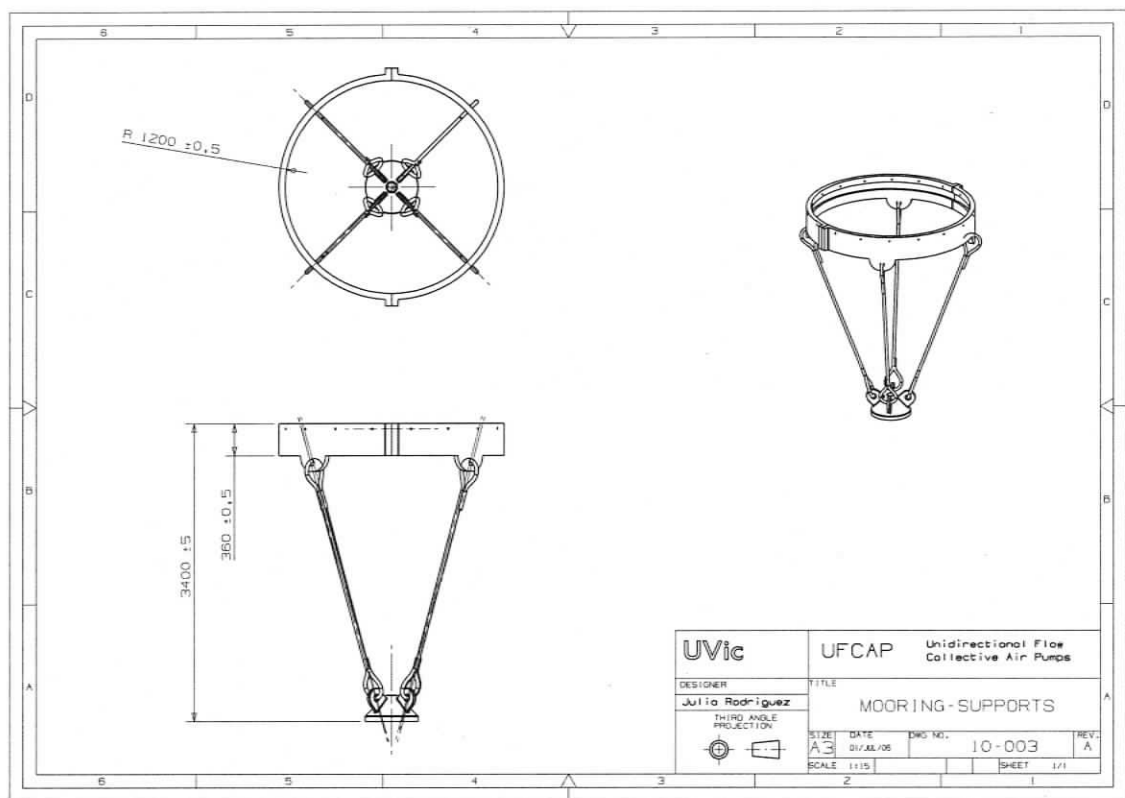

Figure 4.4: Mooring Supports

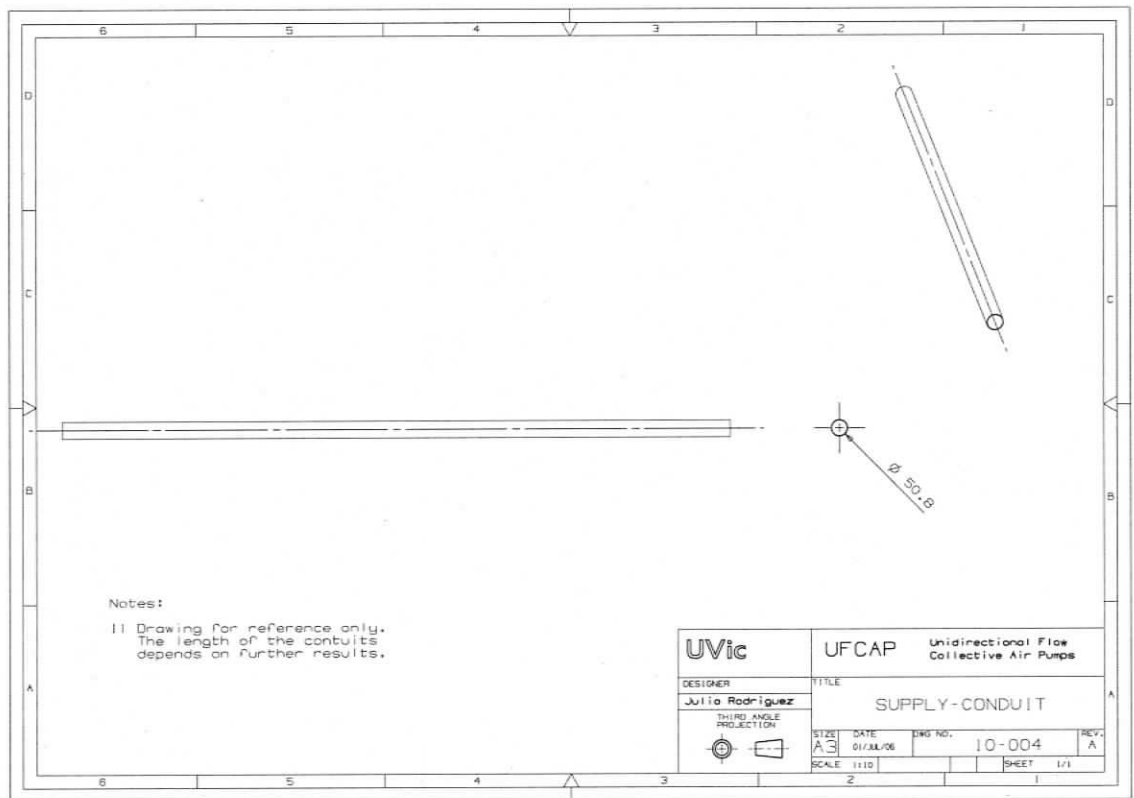

Figure 4.5: Supply Conduit

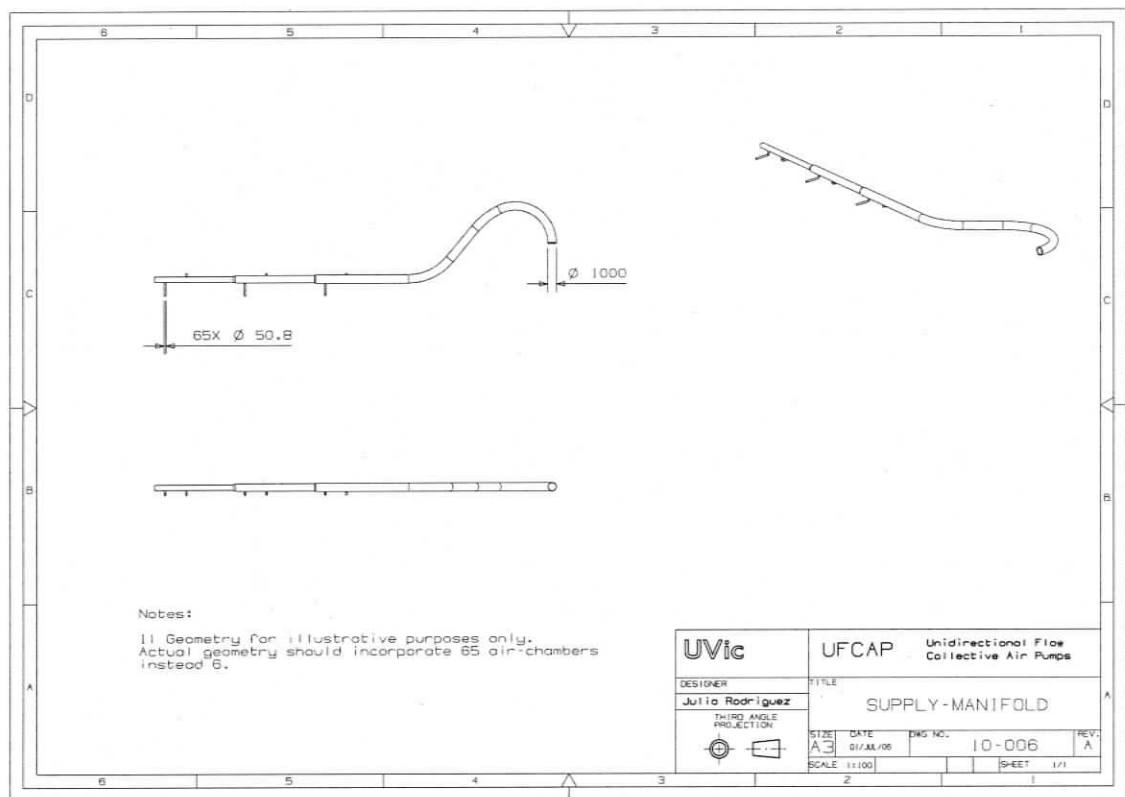

Figure 4.6: Supply Manifold

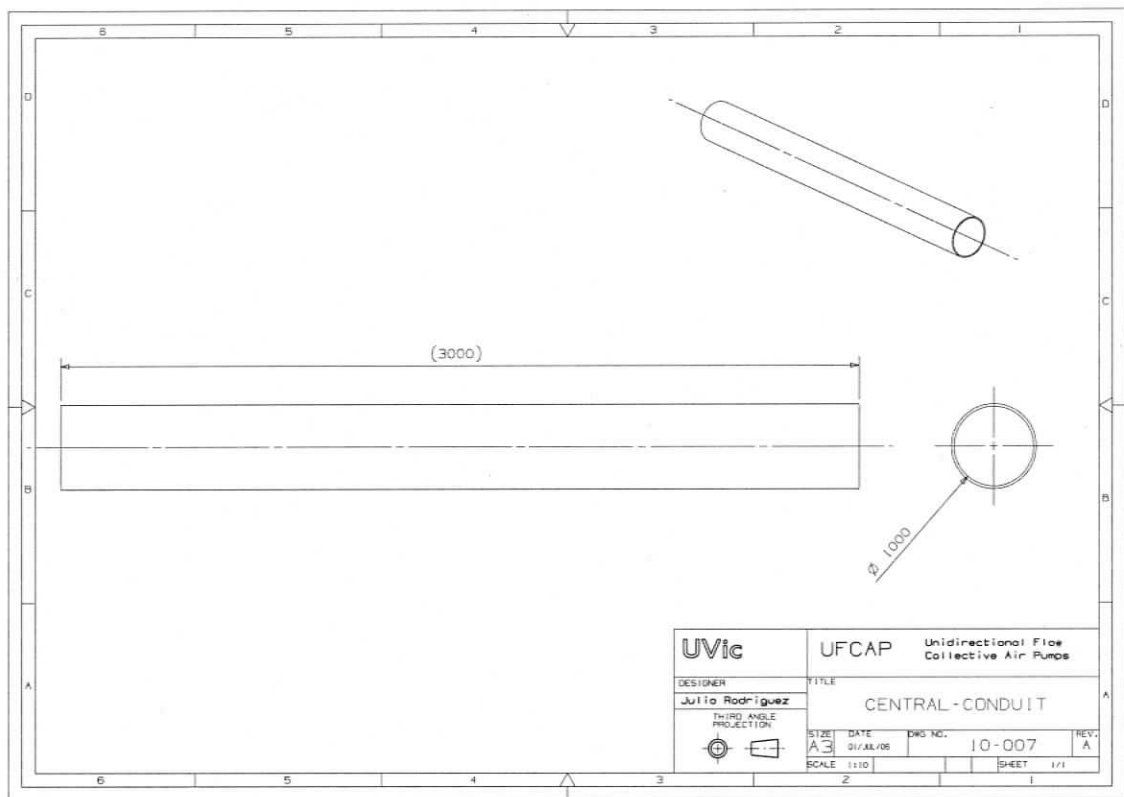

Figure 4.7: Central Conduit

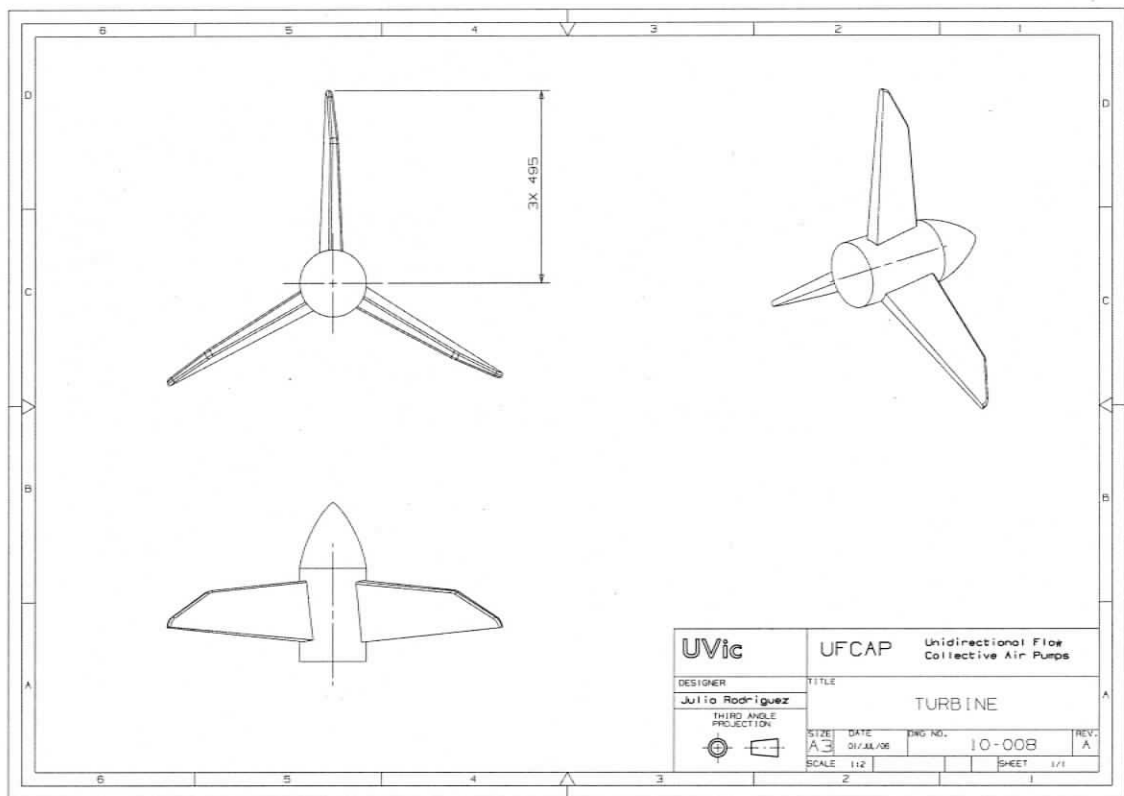

Figure 4.8: Wind Turbine

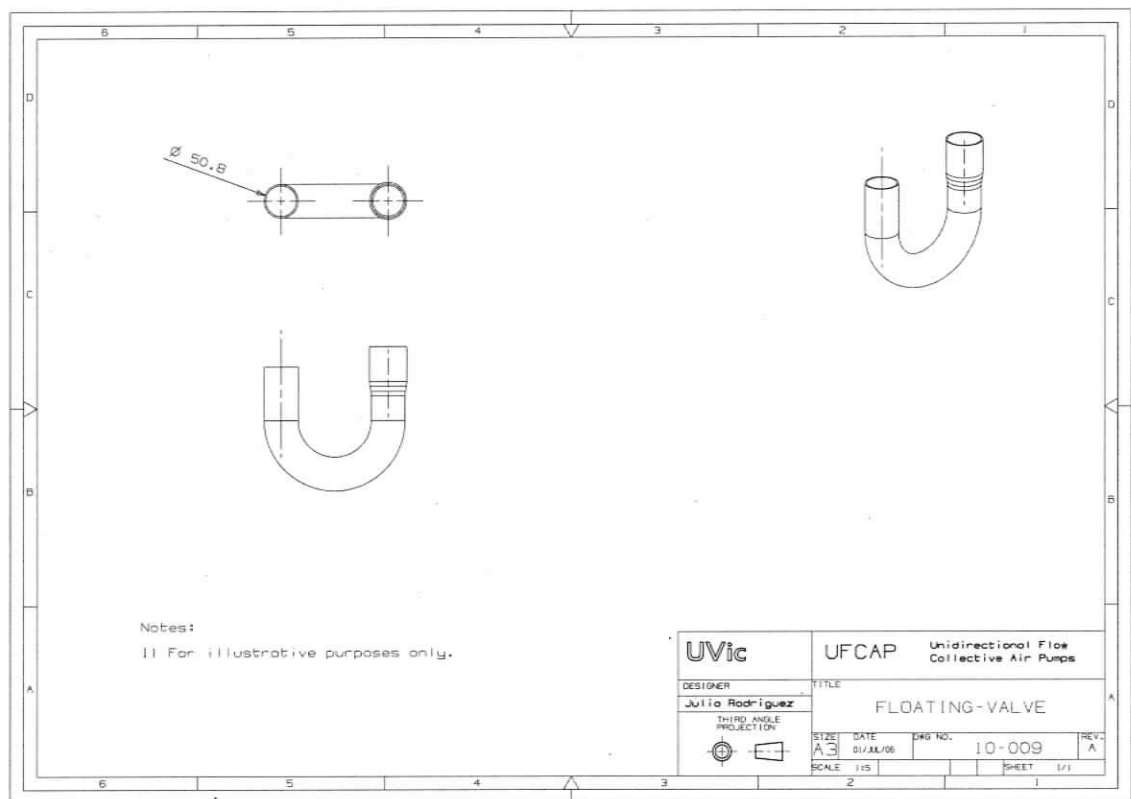

Figure 4.9: Floating Valve

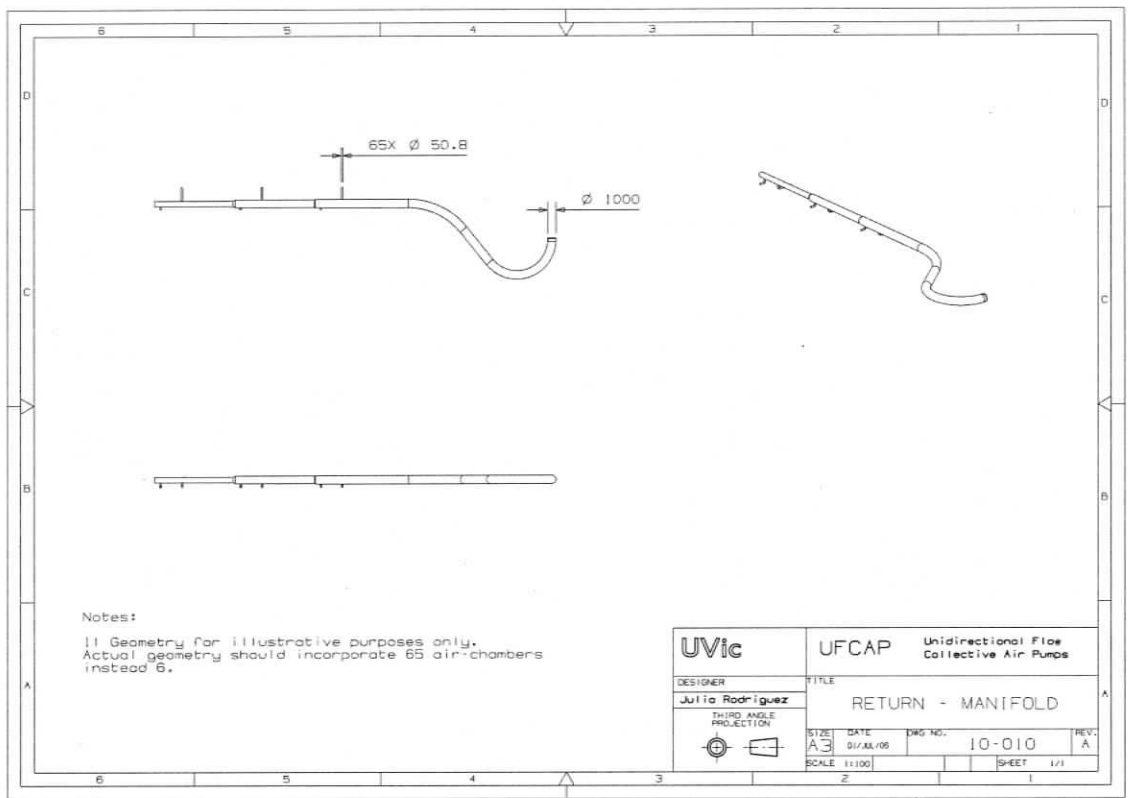

Figure 4.10: Return Manifold

Chapter 5

Conclusions and Future Research

A novel wave energy converter (WEC), designed to minimize the production cost of electricity per kWh based on its simplicity as well as the inherent handling problems based on its modularity and small size, has been proposed. Being a novel technology, a patent was filed [40] under the PCT agreement (see Appendix C). A proof-of-concept experimental setup and a theoretical model were built to prove the feasibility of the concept.

An analytical model was developed to compute the maximum energy that can be extracted from the device. The proposed device was sized for the particular wave conditions off Vancouver Island based on a parametric study. Technical data for the of-the-shelf components and the the manufacturable parts were presented.

Although the proof-of-concept experiment and the numerical analysis of the air chamber using computational fluid dynamics simulations provided sufficient evidence on the merits of the idea and the proposed device, it will be necessary to build a prototype for operation of the UFCAP system on a wave tank in order to accurately assess the device under proper operational conditions.

It was found that the volume of fluid model, used in the numerical analysis, was very sensitive to mesh variations. Therefore, special care should be taken on this

matter to achieve a proper convergence of the problem and real results.

A formal optimization process should be carried out in order to end up with an optimal design. Such optimization should include real sizes and prices of the stock components, and should be accomplished with consideration to the cost and efficiency. The outcome should make evident the main advantage of UFCAP against its competitors, which is the low \$ per kWh.

Wave fronts arrive to the shore not in a fixed direction, but in a variety of directions. This fact would change the sequence of the pumping of the air-chambers into the manifold, which might potentially cause backflow inside the manifold even though no backflow is present at the predominant wave front direction. The location and number of air-chambers would play a prominent role in this regard. Thus, this potential problem should be studied in detail in order to avoid backflow and minimize intermittency for all directions of wave fronts and at the same time, try to minimize the length of the pipes in order to keep the costs low.

The installation can be accomplished with no air inside the system, to avoid unwanted forces. The air can be injected further on.

Finally, during the detailed design stage, the structural analysis on air-chambers and mooring-supports should be carried out.

With respect to the performance of the proposed system, the following conclusions can be drawn:

- The number of air-chambers has a direct impact on the intermittency issue, and the larger the number of air chambers, the less the intermittency. However, by increasing the number of air chambers the cost of the system is impacted directly since this requires more check valves, more piping, and certainly more air-chambers by itself.
- Decreasing the diameter of the central conduit has a two-sided effect. It de-

creases the ΔP_{eff} which slightly decreases the airflow, and at the same time increases the velocity of the airflow by decreasing the cross section area. Since the power is proportional to the third power of the velocity, the net result is an increment in the power available. Nevertheless a given array has an allowable *minimum* for the area of the central conduit cross section. Passing this minimum would cause the system to operate improperly diminishing its efficiency.

- The system should be sized for the most predominant wave heights (generally 1 – 3m). Sizing a system for larger waves, such as 5 or 6 meters, would elevate the cost with almost no gain because the occurrence of such a waves is negligible. Then, it is preferable to “waste” excess energy rather than to invest in a bigger and more expensive system that it is rarely used for larger waves [41] [42].
- The dimensions on the air-chamber impact directly both the cost and the amount of airflow. The determination of its size should be further researched during the optimization process.
- Varying the depth of the system has different effects. It varies directly the operating pressure which in turn changes the viscosity and the density of the air. The effect of viscosity changes on the output is negligible. The effect of the density changes are visible since the energy carried by a fluid is directly proportional to its density. In addition, the amplitude of the water level variation ach which controls the amount of airflow Φ is affected by the weight (or density) of the air, being the larger the density, the smaller the ach . These two effects act in opposite directions having an impact on the net output of the device. However, it was found that changing the density also changes the value of the *minimum* area allowable of the central conduit cross section mentioned above. Then, when the system is adjusted with the new central conduit diameter, the effects of changing the density are cancelled. Therefore, no importance should be given to the depth as a design variable in terms of power output, but it

should be taken into account that increasing the depth of the system makes installation more difficult.

- Although a different fluid rather than air can be used, it is questionable for reasons of cost, handling and replacement.

In conclusion, the aim of this work was to present a novel WEC and create a base for further work. For all of its advantages (see section 2.4), the UFCAP design has the potential to be a competitive product within the renewable market and bring the production cost of electricity to a levels below than other currently available WECs.

Reducing the cost and difficulties inherent to the renewable systems is fundamental to make them affordable and operable and to effectively reduce the CO_2 emissions.

References

- [1] TW. Thorpe. An overview of wave energy technologies. Technical Report AEAT-3615, A report produced for the Office of Science and Technology, AEA Technology Report Number AEAT-3615, 1998.
- [2] V. Smil. *Energy at the Crossroads*. MIT Press, 2003.
- [3] Anugerah Widiyanto, Seizo Kato, Maruyama, Naoki, and Yoshimasa Kojima. Environmental impact of fossil fuel fired co-generation plants using a numerically standardized lca scheme. *Journal of Energy Resources Technology, Transactions of the ASME*, 125, n 1(1):9–16, March 2003.
- [4] et al M. Hoffert. Engineering: Advanced technology paths to global climate stability: Energy for a greenhouse planet. *Science*, 298(5595):981–987, 2002.
- [5] United Nations Framework Convention on Climate Change. *Kyoto Protocol*. Available online from http://unfccc.int/essential_background/kyoto_protocol/items/2830.php, [Cited April, 2005].
- [6] S Pneumaticos. Renewable energy in canada status report 2002: A national report prepared for the renewable energy working party (rewp) of the international energy agency (iea), office of energy research and development - natural resources canada. Technical report, 2002.

- [7] Energy Information Administration. Annual energy outlook 2006. Technical Report DOE/EIA-0383(2006), February 2006.
- [8] BP. Statistical review of world energy 2005, June 2005.
- [9] BP. *Understanding energy markets*. Available online from <http://www.bp.com/extendedsectiongenericarticle.do?categoryId=2010208&contentId=2017295>, [Cited April 04, 2006].
- [10] Baker Institute Study. Running on empty? prospects for future world oil supplies. Technical Report Study No. 14, James A. Baker III Institute for Public Policy of Rice University co-sponsored by the Petroleum Industry Research Foundation, 2000.
- [11] International Energy Agency. Status and research and development priorities 2003 wave and marine current energy. Technical report, 2003.
- [12] R Bedard. Final summary report project definition study: Offshore wave power feasibility demonstration project. Technical Report Report E21 EPRI Global-WP-009-US-Rev1, Electricity Innovation Institute, 2005.
- [13] Offshore Resource and Energy Group. A proposal for a collaborative research and development program for enabling renewable ocean energy delivery in british columbia and canada. Technical report, OREG Report, 2004.
- [14] California Energy Commission. *Ocean Energy*. Available online from <http://www.energy.ca.gov/development/oceanenergy/>, [Cited November, 2005].
- [15] M Previsic. The state of the art in wave energy conversion. *Sea Technology*, 44(7):15–18, 2003.
- [16] Ocean Power Delivery Ltd. *Home Page*. Available online from <http://www.oceanpd.com>, [Cited April, 2005].

- [17] Mirko Previsic. E2i epri assessment. offshore wave energy conversion devices. Technical Report E21 EPRI WP-004-US-Rev 1, Electricity Innovation Institute, June 16, 2004.
- [18] Carbon Trust. Marine energy challenge, July 2005. Marine Energy Glossary.
- [19] Wavegen. Research into the further development of the limpet shoreline wave energy plant. Technical report, DTI, 2002.
- [20] The Queen's University of Belfast. Islay limpet wave power plant. Technical Report Contract JOR3-CT98-0312, 2002.
- [21] Jens Peter Kofoed, Peter Frigaard, Erik Friis-Madsen, and Hans Chr. Sorensen. Prototype testing of the wave energy converter wave dragon. *Renewable Energy*, 31(2):181–189, 2006.
- [22] Henk Polinder, Member, IEEE, Michiel E. C. Damen, and Fred Gardner. Linear pm generator system for wave energy conversion in the aws. *IEEE Transactions on Energy Conversion*, 19(3):583–589, September 2004.
- [23] G.D. Crapper. *Introduction to Water Waves*. Ellis Horwood Limited, 1984.
- [24] Michael E. McCormick. *Ocean Engineering Wave Mechanics*. John Wiley & Sons, Inc., 1973.
- [25] Ross Henderson. Design, simulation, and testing of a novel hydraulic power take-off system for the pelamis wave energy converter. *Renewable Energy*, 31:271–283, 2006.
- [26] IEEE Power Engineering Society. Energy Development and Power Generation Committee. *2005 Panel Session: Harnessing the Untapped Energy Potential of the Oceans: Tidal, Wave, Currents and OTEC*. In *General Meeting, San Francisco*, 12-16 June 2005.

- [27] UK Ministry of Defence. Compressed air systems. Defence Standar 02-314 Issue 3, October 2005.
- [28] Fluent, Inc. *Fluent 6.1 User's Guide*, Feb 2003.
- [29] K. Dumont, J.M.A. Stijnen, J. Vierendeels, F.N. Van de Vosse, and P.R. Verdonck. Validation of a fluid-structure interaction model of a heart valve using the dynamic mesh method in fluent. *Computer Methods in Biomechanics and Biomedical Engineering*, 7(3):139-146, 2004.
- [30] David M. Eggleston Forrest S. Stoddard. *Wind Turbine Engineering Design*. Van Nostrand Reinhold Company, 1987.
- [31] James E.A. John William L. Haberman. *Introduction to Fluid Mechanics*. Prentice Hall, 1988.
- [32] Louise St.Germain. A case study of wave power integration into the ucluelet area electrical grid. Master's thesis, University of Victoria, 2005.
- [33] Inc. Chem-Tainer Industries. *Home Page*. Available online from <http://www.chemtainer.com>, [Cited April, 2006].
- [34] Georg Fischer Piping System. *Home Page*. Available online from <http://www.us.piping.georgefischer.com/>, [Cited April, 2005].
- [35] Barry V. Davis. Low head tidal power - a major source of energy from the world's oceans. In *Proceedings of the Intersociety Energy Conversion Engineering Conference*, volume 3-4 of *Energy Systems, Renewable Energy Resources, Environmental Impact and Policy Impacts on Energy*, pages 1982-1989. Proceedings of the 1997 32rd Intersociety Energy Conversion Engineering Conference, IEEE, 1997.
- [36] L.M.C. Gato, A.F. de O. Falcao, N.H.C. Pereira, and R.M.R.J. Pereira. Design of wells turbine for owc wave power plant. *Proceedings of the First International*

- Offshore and Polar Engineering Conference*, pages 380–384, 1991. Proceedings of the First International Offshore and Polar Engineering Conference.
- [37] Kunal Ghosh. Cascade wind turbines for the oscillating water column wave energy device: Part 1. *Renewable Energy*, 9(1-4):1219–1222, 1996.
- [38] The Queen’s University of Belfast. Islay limpet wave power plant. Contract JOR3-CT98-0312, 1 November 1998 to 30 April 2002. Research funded in part by the European Commission.
- [39] Gary L. Johnson. *Wind Energy Systems*. Electronic Edition, 2001.
- [40] Julio Rodriguez and Afzal Suleman. Aparato para transformar la energia de las olas del mar en energia mecanica. PCT/MX2006/000056.
- [41] Mats Leijon, Hans Bernhoff, Marcus Berg, and Olov Agren. Economical considerations of renewable electric energy production— especially development of wave energy. *Renewable Energy*, 28:1201–1209, 2003.
- [42] Hans Bernhoff, Elisabeth Sjostedt, and Mats Leijon. Wave energy resources in sheltered sea areas: A case study of the baltic sea. In *Fifth European Wave Energy Conference*. Uppsala University, 2003. In Cork, Ireland.
- [43] D.J. Acheson. *Elementary Fluid Dynamics*. Clarendon Press Oxford, 1990.
- [44] E. Baddour. Energy from waves and tidal currents towards 20xx? Technical report, Institute for Ocean Technology, National Research Council, 2004.
- [45] DG XVII Commission of the European Communities. An assessment of the state of art, technical perspectives and potential market for wave energy. Technical report, prepared by ETSU and CCE, 1992.
- [46] I.G. Currie. *Fundamental Mechanics of Fluids*. McGraw-Hill, Inc., 1993.

- [47] L.J. Duckers, F.P. Lockett, B.W. Loughridge, A.M. Peatfield, M.J. West, and P.R.S. White. Optimisation of the clam wave energy converter. *Renewable Energy*, 5:1464–1466, 1994.
- [48] M. Eriksson, J. Isberg, and M. Leijon. Hydrodynamic modelling of a direct drive wave energy converter. *International Journal of Engineering Science*, 43:1377–1387, 2005.
- [49] Ross Henderson. Design, simulation, and testing of a novel hydraulic power take-off system for the pelamis wave energy converter. *Renewable Energy* 31, 31:271–283, 2006.
- [50] William S. Janna. *Introduction to Fluid Mechanics*. PWS, 1993.
- [51] Jens Peter Kofoed, Peter Frigaard, Erik Friis-Madsen, and Hans Chr. Sorensen. Prototype testing of the wave energy converter wave dragon. *Renewable Energy*, 31:181–189, 2006.
- [52] Takao Maeda and Hideyuki Kawabuchi. Surface pressure measurement on a rotating blade of field horizontal axis wind turbine in yawed condition. *JSME International Journal*, 48(1):156–163, 2005.
- [53] Jerzy A. Owczarek. *Introduction to Fluid Mechanics*. International Textbook Company, 1968.
- [54] Mukund R. Patel. *Wind and Solar Power Systems*. CRC Press, 1999.
- [55] F. M. White. *Fluid Mechanics*. Mc Graw-Hill, fourth edition edition, 1999.
- [56] G. Wick and W. Schmitt. *Harvesting ocean energy*. UNESCO Press, 1981.
- [57] Andrzej J. Wortman. *Introduction to Wind Turbine Engineering*. Butterworth Publishers, 1983.

- [58] John F. Wendt, editor. *Computational Fluid Dynamics An Introduction*. Springer-Verlag, 1992.

Appendix A

UDF for Creating the Inlet Pressure $P(t)$

```
/******  
unsteady.c  
UDF for specifying a transient velocity profile boundary condition  
*****/  
#include "udf.h"  
DEFINE_PROFILE(pres_ch, thread, i)  
{  
    face_t f;  
    real t = CURRENT_TIME;  
    real pi = 3.14159;  
  
    begin_f_loop(f, thread)  
    {  
        F_PROFILE(f, thread, i) = 10074.87 + 7556.15*cos(pi/40.*0.+ pi/2. -  
            (0.6981317)*t);  
    }  
}
```

```
}  
end_f_loop(f, thread)  
}
```

Appendix B

Check Valves Specifications

Series CKS Check Valves 1 1/2", 2" and 3"

Operation:
 Flow entering the valve inlet will open the valve by pushing the poppet off the valve seat. In this position, the valve seat is kept clean by flushing action of the internal flow, keeping the entire sealing area free of particles which could cause leakage.
 If the inlet flow is stopped, or if a backflow of a higher pressure is sensed, the spring-loaded poppet will automatically reposition itself, closing off the valve seat. Reverse flow or pressure is not required to close the valve when the inlet flow stops. If reverse pressure is present it simply creates a tighter seal.



Installation:
 Because of their normally-closed design Plast-O-Matic CKS Check Valves can be installed in any position. Concern over the valve seat closing due to gravity (as with ball check designs) is of no consequence since CKS valves seal in any position. Caution should be exercised to make certain that the direction of flow is correct. Threaded connections should never be made to metal piping and should always be wrapped with Teflon® or other acceptable pipe sealant to effect a seal. The assembly need only be made hand-tight followed by a one-quarter turn more with a strap wrench. **DO NOT** overtighten and **DO NOT** use a pipe wrench as a future valve fracture could result.

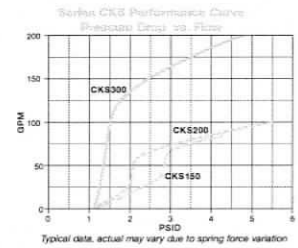

Series CKS Pressure Ratings

VALVE BODY MATERIAL	MAXIMUM WORKING PRESSURE		
	77°F (25°C) Inlet & Reverse	105°F (40°C) Inlet & Reverse	AT MAXIMUM TEMPERATURE Inlet & Reverse
PVC	150 PSI 10 BAR	100 PSI 7 BAR	40 PSI @ 140°F 3 BAR @ 60°C
POLYPRO	100 PSI 7 BAR	70 PSI 5 BAR	25 PSI @ 180°F 3 BAR @ 105°C
PVDF (KYNAR®)	150 PSI 10 BAR	120 PSI 8 BAR	30 PSI @ 280°F 2 BAR @ 140°C

1. 140°F (60°C) is the maximum recommended temperature for PVC.
 2. For information on 1/2", 3/4" and 1" self-closing check valves request Catalog CKL.

Series CKS Dimensions & Model Numbers

PIPE SIZE (NPT)	Cv	A		B		C		MODEL NUMBER
		in.	mm	in.	mm	in.	mm	
1 1/2"	45	7.4	188	2.5	64	3.5	88	CKS150VT-NC-PV
2"	45	8.4	213	3.3	83	4.5	114	CKS200VT-NC-PV
3"	95	9.9	251	4.3	109	5.5	140	CKS300VT-NC-PV

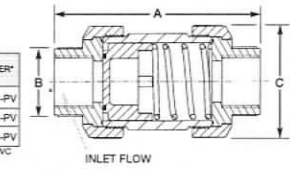

*Model numbers shown for valves with Viton seal, threaded connection and PVC body material.
 1. For Buna-N seals, change first "V" to "B"; i.e. CKS150BT-NC-PV.
 For EPDM seals, change first "V" to "EP"; i.e. CKS150EPT-NC-PV.
 2. For socket connections, change "T" to "S"; i.e. CKS150S-NC-PV.
 3. For Natural Polypropylene body change "PV" to "PP".
 For Kynar PVDF body change "PV" to "PF"; i.e. CKS150VT-NC-PF

PLAST-O-MATIC VALVES, INC.
 1384 Pompton Avenue, Cedar Grove, NJ 07009
 (973) 256-3000 • Fax (973) 256-4745
 www.plastomatic.com • info@plastomatic.com

AUTHORIZED PLAST-O-MATIC DISTRIBUTOR

Figure B.1: Check Valve Specifications

Appendix C

UFCAP Patent

The original document was filed in Spanish. A former traslation in English is presented here. See reference [40]

A portion of the disclosure of this patent document contains material which is subject to copyright protection. The copyright owner has no objection to the facsimile reproduction by anyone of the patent document or the patent disclosure, as it appears in the Patent and Trademark Office patent file or records, but otherwise reserves all copyright rights whatsoever.

Title

Unidirectional Flow Collective Air Pumps (UFCAP), a Wave Energy Converter

Abstract

UFCAP is a Wave Energy Converter that can be described as an array of submerged air chambers from where by action of the ocean waves and by means of a couple of check valves on each chamber, air or other gas is pumped unidirectionally to drive a common turbine. Its modularity and simple design with no moving parts touching the water make it easy to manipulate and attractive in terms of cost and environment impact. Common applications are: electricity generation, Hydrogen-Oxygen production or water desalinization.

Claims

What is claimed is:

1. A system for utilizing the ocean wave energy comprising:
 - a) an array of at least two submerged air chambers that are moored to the ground, having air trapped in its upper interior, and having an opening in wherever the bottom area that permits the flow of water to the inside of the chamber in order to transmit the variable pressure of the water to the air in the interior of the chamber;
 - b) a mooring means to hold submerged the system as needed;
 - c) supply conduit means that lead air from the individual said air chambers to the supply manifold means;
 - d) check valve means for each supply conduit means permitting air flow only in the direction toward the turbine entrance;
 - e) a supply manifold means that collects and transmits the air coming from said supply conduits up to the supply nozzle;
 - f) an inlet nozzle that is connected to said supply manifold means to concentrate and guide the air to the entrance of the turbine;
 - g) a turbine;
 - h) an outlet nozzle to expand and guide the air from the exit of the turbine to the return manifold means;
 - i) a return manifold means that takes the air coming from said outlet nozzle and distributes it to the return conduit means;
 - j) return conduit means that lead the air from said return manifold means to said air chambers;
 - k) check valve means for each return conduit means permitting airflow only in the direction toward the air chamber;
 - l) mooring means to keep submerged and fixed the conduit supply, conduit return, supply manifold, and return manifold means.

2. The system according to claim 1, wherein the airflow is unidirectional.
3. The system according to claim 1, wherein a fluid less dense than water is used to drive the turbine.
4. The system according to claim 1, wherein the supply and return conduit means inside the chamber have a buoying valve means that secure the conduit means against water intrusion during big waves.
5. The system according to claim 1, wherein the supply and return conduit means have a second check valve means at an afterward position to prevent retro flow.
6. The system according to claim 1, wherein the turbine is placed on shore.
7. The system according to claim 1, wherein the turbine is submerged
8. The wave energy converter according to claim 6, wherein mooring support means hold the turbine underwater.

Description

BACKGROUND OF THE INVENTION

1. Field of the Invention

The present invention relates to a system able to use the potential energy of the ocean waves to make rotate a turbine, which can be further used to generate electricity, produce Hydrogen-Oxygen, desalinate water, or a combination of them.

2. State of the Art

During the last years, the presence of global warming due to the green house gas emissions has become evident. Although scientist haven't gotten a consensus about what the consequences will be, they all are sure that global warming will have a disastrous impact in the ecosystems if it continues growing the rate is has so far.

For this reasons, the use of renewable energies has been promoted from several governments and institutions. However, although the interest in using renewable energies to supply our power necessities exists, renewable energies haven't had all the growth they should have due to one reason: they are still more expensive than fossil fuels.

Ocean Wave Energy technology has been in research and development for the past few decades. From all the renewable energies, ocean wave is the form that has more different approaches to harvest the renewable resource. There are literally hundreds of inventions working under different principles.

Among the most relevant and developed devices closer to commercial stage are the:

- a) Limpet, Azores, Mighty Whale, Energetech,
- b) Pelamis,
- c) Wave Dragon,
- d) Wave Swing.

The first group uses a principle called "Oscillating Water Column (OWC)," which uses an air chamber placed at the surface of the ocean having typically two openings: one placed at the bottom part and making contact with the ocean surface and the second typically at the top part where an air turbine is placed. The elevation and falling of the water level at the bottom of the chamber creates an oscillating airflow, which makes rotate a special turbine that accepts and oscillating flow to further generate electricity.

This kind of devices can be either near shore such as the plants Limpet in UK or the Azores in Portugal, or offshore such as Mighty Whale in Japan or Energetech in Australia.

Although OWC devices are one of the most promising approaches to harvest efficiently the ocean wave energy, they have still some difficulties to deal with. The main inconvenient with the on shore devices is that the suitable locations to place big power plants might be limited and when found, such locations are usually apart from roads and it is difficult to take the heavy machinery for their construction to the place. Also, OWC devices typically use a Wells turbine to account for the oscillating airflow, which is less efficient than its equivalent unidirectional turbine.

Another promising approach and also one of the most developed is the Pelamis, which consists in several articulated cylindrical sections floating off shore, which are moved relative to each other while the wave passes. Such a relative movement actuates pumps that drive pressurized oil through motors to generate electricity. It has excellent survivability characteristics; however, its efficiency still needs to be improved. The fact that its sections are fixed in size, makes it having different efficiencies for different wavelengths. As ocean waves come in all sizes, its overall efficiency is diminished.

The so called Wave Dragon is an overtopping device that concentrates waves to further captures them as they spill into a reservoir. The elevated water is then bled through low head turbines, which generate electricity. It is an enormous device with a width of about 300 m. One of the drawbacks is that it is not easily scalable down to supply small necessities.

Wave Swing is a submerged device that consists of two concentric vertical cylinders. The external cylinder has a volume of air trapped in their interior. When waves pass, they alter the ambient water pressure changing the pressure of the air inside, and then, forcing the external cylinder to oscillate upward and downward. A linear generator converts the motion into electricity.

By being an underwater device, it addresses one of the most important concerns in wave industry, which is the survivability of the device. Under water devices are safer since the susceptibility to storms decrease exponentially with the deep of the water; this, together with the fact that it only has one moving part has given the Wave Swing wide acceptance. However, being a big underwater device could be also a problem since maintenance might require floating the device to do any repair. Floating a device of such dimensions (9.5m diameter) and weight is not an easy task.

Even though the previous listed devices are the most developed, no one can compete in price with the electricity generated from fossil fuels, and except from the OWC devices all others have moving parts in contact with the water that can potentially damage the marine wild life.

There are other inventions that although have not been really developed, are in close relation with the present invention and thus, they are important to mention.

These devices elevate the pressure of a fluid and use it to further drive a turbine or a motor. They pump the fluid by using an array of reservoirs with at least one of their walls being flexible and this way the reservoir is able to decrease and increase its volume and pump the fluid.

One example is the device in Lesster, et al. U.S. Pat. No. 3,989,951 that describes an apparatus that consists in a series of adjacent underwater pneumatic cells, which has the upper wall flexible. It uses the pressure changes created from the waves, passing to inflate and deflate the pneumatic cells which use this volume change to pump air through a turbine. Cells use an external concrete cover to protect the flexible material from damage. With the help of a couple of check valves per cell it directs the air unidirectionally. One of the drawbacks of this patent is the necessity of an extra wall to protect the cell because it will increase the cost of the system.

Furthermore, in order to avoid an intermittent airflow, it is necessary that the individual cells pump air sequentially without interruptions. Such an effect can only be achieved by having an array of sufficient size, typically more than one and a half wavelengths. Since the array proposed by Lesster use adjacent cells, there is not alternative but being a huge system since a typical wavelength is on the order of 120 m. The present invention uses a spaced array of air chambers that allows the system exceeding the size of a typical wavelength, achieving a more uniform airflow.

Another example of flexible components is the Meyerand U.S. Pat. No. 4,630,440, which describes an apparatus for power generation that consists in an array of chambers comprising two housings, one inside the other and having water in between. The outer housing having at least one opening to the water, and a turbine located on it. The inner housing filled with a gas and having a flexible bladder that comprises and decompresses the gas in the interior while the waves pass. The volume within the two housings changes while the flexible bladder changes its volume, the water will be forced to go inside and outside of the outer housing and will drive the turbine.

One of the drawbacks of this invention is that it requires one turbine for each chamber. This could make the cost prohibited. Furthermore, having a material that can meet the requirements of such big deformations and at the same time be durable can be an issue.

Semo in his U.S. Pat. No. 3,353,787 uses a submerged system of elongated tubes with the upper wall flexible that is moved by the action of the waves. When the upper wall is compressed, it pushes an incompressible fluid that is taken to a motor located offshore. It is questionable the fact of rising the incompressible fluid, which has similar density than the water, for above the maximum wave height all the way up to the motor. The underwater concrete walls around the system might elevate the cost of the installation.

Devices using a flexible wall, like the three previously mentioned, have not been successful since they are subject to fail due fatigue since the flexible material is under continuous flexion.

Nevertheless, flexible walls are not the only way to pump a fluid by using the ocean waves. The most common examples of pumping devices are the OWC's explained above. Other devices, that also pump air, use a piston-like mechanism. Graff U.S. Pat. No. 4,001,597 discloses a device that consists in a plurality of compression cylinders that are activated by the downwardly movement of a hinged rigid pressure plates that oscillates as the waves pass. Meano U.S. Pat. No. 6,800,954 discloses a device that uses a piston that rises and falls by action of the waves to pump air from the atmosphere to a pressurized chamber.

Unlike all of them, the present invention uses an underwater mechanism with no moving parts to pump the air.

Objective

It is an object of the present invention to provide a system for wave energy conversion that is cheaper than the current wave energy converters and thus, make their applications, such as electricity generation from the ocean waves, more competitive.

Simplicity is the key factor that makes possible get the expected low cost. The system uses only one complex part, which is the turbine. Furthermore, there are only two kinds of moving parts within the system: the valves and the turbine. The rest of the components are very simple. Valves and conduits can be commercial parts, which is cheaper rather than developing new technology, and the manifold, supports, and air chambers can be easily manufactured because they are no complex parts.

In addition, the turbine used by the present invention doesn't have to be a special turbine that accepts an oscillating flow, as it is needed by the OWC devices; this turbine can be a conventional turbine, which is more efficient and that can also be bought from the well-developed turbo-machinery industry.

Also, there are not high stresses or pressures like those that are present in other devices that are at the surface of the ocean, or that use hydraulic motors; then, the air chamber and supply conduits can be made of non expensive materials such as plastic.

The last feature that reduces cost is its modularity. By being a modular system, it can be easily managed, unlike other wave energy converters that are usually very big. The cost associated to manufacture, transportation and installation is highly reduced.

A further object of this invention is to provide a system which impact on the underwater ecosystem can be minimized. By having no moving parts in contact with the water, the applicants expect that the system will have minimum impact on the marine life.

Another object of the present invention is to present an apparatus that have excellent survivability characteristics to account for the sometimes oceans' aggressive environment and that doesn't affect the negatively neither the navigation nor the seascapes.

In addition, it is an object to provide a device that can operate long periods of time without supervision. The applicants expect that the maintenance in the no moving components will be almost null. On the other hand, the maintenance of the turbine is expected to be low due to the known long life of this kind of devices. However, whenever maintenance is needed, the turbine can be easily removed by being a relatively small part.

SUMMARY OF THE INVENTION

The present invention consists in a submerged array of spaced vertical air chambers wherein the air trapped in their interior is constantly pumped in and out of the chamber by the action of the water level that increases and decreases in the interior of the chamber. Each said air chamber has two conduits, one wherefrom the air is taken out and other wherefrom the air is taken into the chamber. The earlier conduits are called a supply conduits because they feed the turbine while the former are called the return conduits because take the air from the outlet of the turbine back to the chambers. Check valves are disposed in the supply and return conduits in opposite directions to make sure a unidirectional flow is kept.

Since the system is composed of a plurality of air chambers, the supply conduits are collected in a component called the supply manifold, which leads the air toward the inlet nozzle, which concentrates the air at the entrance of the turbine. Once the air has passed through the turbine, it is passed to the outlet nozzle and then to the return manifold which distribute the air to the return conduits for its return into the air chambers.

BRIEF DESCRIPTION OF THE DRAWINGS

Fig. 1 is a schematic of an exploded view of the assembly including the main parts of the apparatus referred in the present invention.

Figs. 2 and 3 show a section view of the submerged air chamber and explain the principle that the present invention uses to create the airflow that drives the turbine.

Fig. 4 is a top view of an array of air chambers and is intended to explain the principle that the present invention uses to have a more uniform flow. The transmission lines are not included in this figure.

Fig. 5 is a complement of fig. 4 and shows a front view of a wave including its direction of propagation and also shows what part of the wave is used to create the supply airflow, and what part is used to create the return airflow.

Detailed DESCRIPTION OF THE PREFERRED EMBODIMENT

Figure 1 shows an exploded view of the embodiment displaying only one air chamber to make clearer the schematic. It is important to note that a complete system would be compound of a plurality of air chambers.

The principle that makes circulate the air within the closed circuit is explained with Fig. 2 and 3. The air chamber 1 is kept approximately in vertical position by the action of the buoyant force of the air 13 in its interior and hold to the ground by the mooring means 2. While the crest 12 is approximating above the air chamber 1, the ambient pressure gradually increases and forces the air 13 to go to another place at lower pressure. The displacement of the air 13 outward the air chamber can be seen in the change of the water level from the position 14b to the position 14a. Since the check valve 11 is closed in the direction outward the air chamber, the only via available for the air to take is the supply conduit means 3. The check valve 4 is opened at this point since it allows flow in the direction toward the manifold 5.

The opposite process comes when the trough 15 is approximating to the air chamber 1 and it is explained in figure 3. In this case, the ambient pressure gradually decreases and forces the air to go inward the air chamber for being in there at lower pressure. The displacement of the air 13 inward the air chamber can be seen in the change of the water level from the position 14a to the position 14b. Since Check valve 4 is closed in the direction toward the air chamber, then, the air is coming only from the return supply means 10. Check valve 11 is opened at this point.

Supply manifold 5 receives air from a plurality of supply conduit means 3 coming from several individual air chambers from the array. Supply manifold 5 is connected to inlet nozzle 6 that concentrates the air and directs it to the entrance of the turbine 7. Air passing through, will drive the turbine 7. Outlet nozzle 8 connects the outlet of the turbine with the manifold 9 that distribute the air to a plurality of return conduit means 10. Finally air is returned to the individual air chambers 1.

Current wave technology is not competitive in applications such as electricity generation due to the high cost while compared to fossil fuel technologies. In order to take wave technology to the commercial stage, it is necessary that such technology be, not only

ambient friendly but also, competitive in terms of cost. This is probably the only way to spread out the use of the renewable energies and slow down the emissions of the green house gases.

Additional References

- Previsic, et al. E21 EPRI Assessment. *Offshore Wave Energy Conversion Devices*. June 16, 2004.

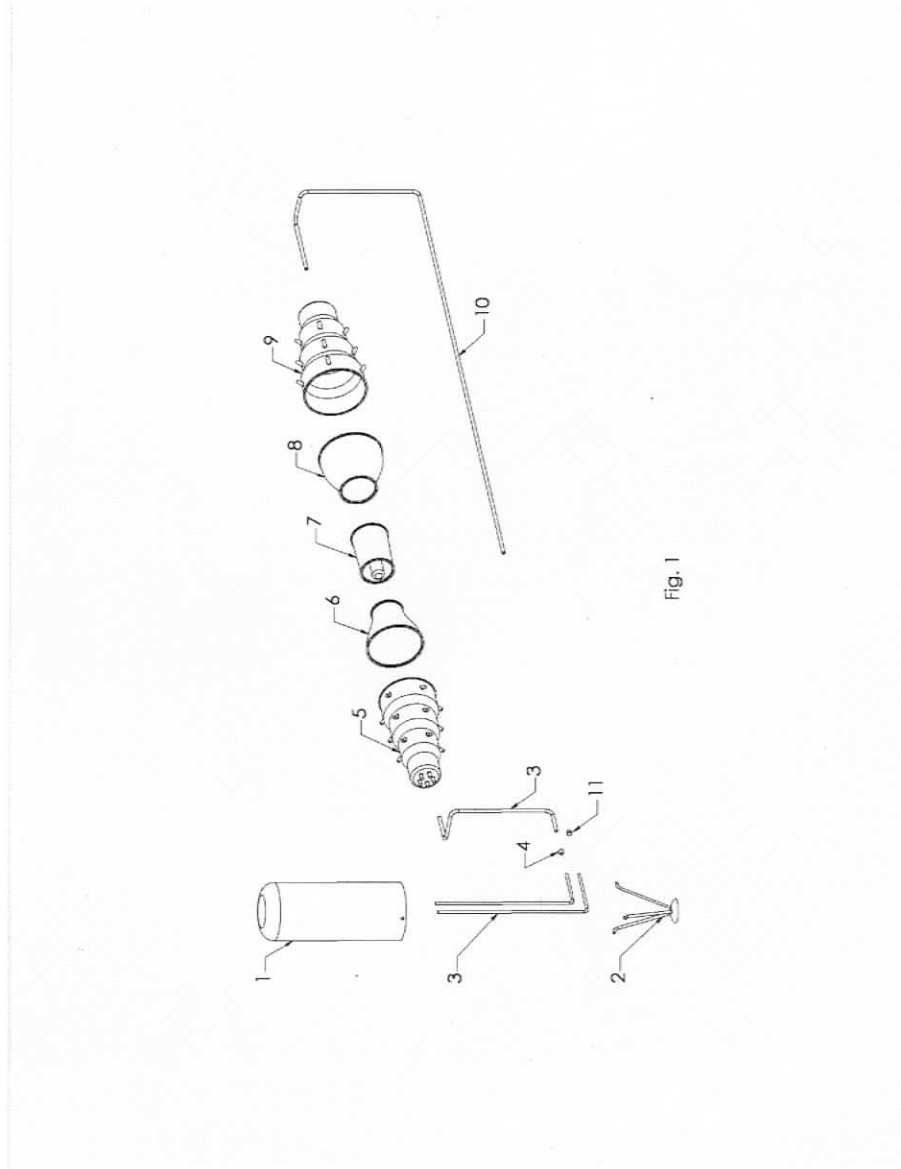

Fig. 1