

Circular Waste Audit Standard Operating Procedure

Submitted in fulfillment of the requirements for the
Sustainability Scholars Program

Authored by Jeff Scanlon 2025

Prepared for the University of Victoria

Facilities Management

Office of Campus Planning and Sustainability

We acknowledge and respect the Ləkʷəŋən (Songhees and Xwsepsəm/ Esquimalt) Peoples on whose territory the university stands, and the Ləkʷəŋən and W̱ SÁNEĆ Peoples whose historical relationships with the land continue to this day.

Executive Summary

The *Circular Waste Audit Standard Operating Procedure (SOP)* establishes the analytical framework guiding how the University of Victoria (UVic) transforms waste data into actionable indicators of circular performance. Developed collaboratively by the Office of Campus Planning and Sustainability, Facilities Management, and the Sustainability Scholars Program, the SOP enables UVic to progress from diversion-based measurement toward a systems-based understanding of material circularity, directly supporting the university's Climate and Sustainability Action Plan (2030).

This document defines a transparent methodology to integrate data from waste audits and operations into Material Flow Analysis (MFA), intensity metrics, and a Circularity Index (CI); three core analytical components that together visualize and assess how efficiently materials are used and recovered across campus operations. It distinguishes between operational and episodic waste, standardizes waste Generation Areas and end-of-life streams, and provides guidance to calculate transfer coefficients, process flows, MFA diagrams, intensity metrics and CI to produce an annual Circular Waste Performance Report.

By weighting waste pathways according to their circular value (resource recovery < composting < recycling < landfill) the CI provides a more nuanced measure of performance than diversion rate alone, aligning environmental benefit with financial and operational realities.

The SOP also outlines governance roles, required data and software tools, and recordkeeping protocols aligned with UVic's Waste Data Governance Framework. Future directions emphasize documenting episodic and resource recovery flows, integrating circular procurement, defining material stocks, and institutionalizing a quantitative circular waste target.

Through this framework, UVic positions itself as a sustainability leader in circular campus waste operations; linking waste analytics, financial efficiency, and sustainability goals under a coherent, data-driven system to take a step towards operationalizing the circular economy within higher education.

Table of Contents

1	Purpose	1
2	Scope	2
2.1	Waste Audit Frequency.....	3
3	Background and Methodological Basis	4
3.1	Waste Audit Data and Collection.....	4
3.2	Episodic vs. Operational Waste	5
3.3	Generation Areas	5
3.4	End-of-Life Waste Streams.....	6
3.5	Detailed Weight Information.....	7
3.6	Material Flow Analysis (MFA).....	8
3.6.1	UVic System Boundary, Functional Unit and System Processes	8
3.7	Intensity Metrics	9
3.8	Circularity Index	10
3.8.1	Circularity Factors.....	11
3.8.2	CI Result Interpretation	13
3.9	Circular Waste Performance Report	14
4	Definitions and Acronyms	16
4.1	Definitions.....	16
4.2	Acronyms	19
5	Roles and Responsibilities.....	21
6	Materials and Equipment	23
7	Procedure.....	24
7.1	MFA Diagram.....	24
7.1.1	Transfer coefficients.....	25
7.1.2	Process Flows	25
7.1.3	Determine MFA Input Values	26
7.1.4	Creating the MFA Diagram.....	26
7.2	Intensity metrics	27
7.3	CI Calculation.....	28
7.4	Circular Waste Performance Report Preparation.....	28
8	Records and Documentation	30
8.1	Required Records.....	30
9	Future Directions.....	31

9.1	Documenting episodic waste and resource recovery.....	31
9.2	Defining Campus Materials Stocks	32
9.3	Integrating Circular Procurement.....	32
9.4	Institutionalizing Circular Waste Targets	32
10	Appendix.....	35
11	References	38
11.1	Data Sources.....	38
11.2	Resources.....	38
11.3	Endnotes	38

1 Purpose

The purpose of this Standard Operating Procedure (SOP) is to define the analytical framework that enables the University of Victoria (UVic) to more deeply leverage the data it generates from waste audits and daily waste operations. Developed collaboratively by the Office of Campus Planning and Sustainability (OCPS), Facilities Management (FGMT), and the Sustainability Scholars Program (SSP), this SOP provides the structure and methodology needed to translate existing waste data into meaningful circular performance indicators that support institutional progress toward the waste-related goals of the Climate and Sustainability Action Plan (CSAP).

This procedure establishes a consistent, transparent approach for integrating waste audit and operational data into Material Flow Analysis (MFA), intensity metrics and Circularity Index (CI). Together, these analyses quantify how effectively materials are used across campus operations. The resulting indicators strengthen the accuracy of UVic's third-party sustainability reporting (including AASHE STARS, THE Impact Rankings) and provide the data foundation for informed, evidence-based strategic decision-making.

In doing so, the Circular Waste Audit SOP advances UVic's transition from diversion-based waste measurement to circular performance evaluation, ensuring that waste data and analysis are aligned with emerging circular economy principles, regulatory expectations, and accurately reported to the public.

2 Scope

This SOP applies to the planning, data management, and analytical activities associated with Waste Audit's at the University of Victoria's Gordon Head Campus. Alone, it is not a complete waste audit methodology but supplemental data-collection and analysis procedures to ensure Waste Audits incorporate emerging circular principles.

This SOP defines the structure and analytical processes used to integrate Waste Audit and data from daily operations into systems-based assessments, including MFA and CI to visualize and assess waste flows and evaluate the circular performance of UVic's waste systems. The SOP governs how waste audit data are organized, and interpreted to measure material flows, and circularity metrics to inform strategic planning under the Climate and Sustainability Action Plan (CSAP 2030).

This procedure does not describe field methods or calculations used in traditional waste audits, such as determining contamination or composition rates, but instead establishes how audit data are used as inputs for circular performance analysis. Routine waste collection, hauling, and disposal activities managed under Facilities Management, as well as the data management processes outlined in UVic's Waste Data Governance Framework, are also out of scope for this SOP. Collectively, this document defines the analytical boundary for UVic's circular waste reporting, ensuring consistent methodology, data integrity, and comparability across audit cycles and production of annual report summarizing UVic's circular waste performance.

2.1 Waste Audit Frequency

To maintain methodological consistency and ensure the reliability of circular performance indicators, UVic shall establish a recurring schedule for comprehensive Waste Audits. It is recommended a comprehensive Waste Audit should be conducted every three to four years, depending on institutional needs, operational changes, and resource availability. These audits are essential to update waste composition rates, contamination rates, and transfer coefficients, providing the empirical foundation required to calibrate MFA and validate the accuracy of circular performance metrics. The recommended frequency balances analytical rigor with operational practicality, ensuring that waste data remain representative of current campus conditions without creating undue administrative burden.

Between full audit cycles, an annual Circular Waste Performance Report shall be created using hauler/tipping data. This assessment will update key indicators, including the CI, intensity metrics, and MFA-based flow estimates, to monitor progress toward the university's institutional goals and execute third party reporting requirements.

This combined approach, comprehensive Waste Audits every three to four years, complemented by annual Circular Waste Performance Report's, support continuous improvement, transparent reporting, and adaptive resource recovery and waste management. It ensures that UVic's waste data shall remain accurate, actionable, and aligned with evolving circular economy principles, regulatory expectations, and tipping cost hierarchies.

3 Background and Methodological Basis

Historically, UVic’s waste system was evaluated primarily based on its diversion rate. While a useful Key Performance Indicators (KPI), diversion rate alone does not provide the strategic impact required to advance UVic waste related CSAP goals.

The Circular Waste Audit methodology was developed to address these limitations by integrating systems-based analytical tools to enable Generation Area and stream specific assessment, baseline intensity metrics and evaluation of circularity of UVic waste systems.

This SOP formalizes three core analytical components that together define the methodological foundation of UVic’s circular waste measurement system. This includes MFA, intensity metrics, and a weighted CI.

3.1 Waste Audit Data and Collection

Waste Audit data collection must ensure data is collected to enable Generation Area and waste stream specific post audit analysis. In practice this requires collecting data attributes that provide the requisite specificity for the analysis detailed in this SOP. These data attributes and their sources are listed in Table 1.

Table 1. Waste Data Attributes and Sources

<i>Information</i>	<i>Source</i>
<i>Buildings or Infrastructure</i>	Standardized list provided by UVic
<i>Generation Area</i>	Defined list provided/approved by UVic
<i>Date Collected</i>	Waste auditor
<i>Stream</i>	Defined list provided/approved by UVic
<i>Detailed Weight information</i>	Waste auditor

3.2 Episodic vs. Operational Waste

It is important to distinguish between two distinct pathways of generating waste at UVic; operational waste vs episodic waste. Operational Waste is derived from ongoing material throughput from day-to-day campus activities (teaching, research, administration, and food services etc.). Whereas as episodic waste is generated outside of standard operations (i.e. events, renovations, equipment upgrades etc.). As a result, episodic waste is not captured by a third-party Waste Audit, as it does not occur during a standard operating day and would not be captured in an audit.

3.3 Generation Areas

Targeted and strategic insights from Waste Audits requires breaking down the campus into distinct waste Generation Areas (GA) associated with different university services and/or operations. The narrower the scope of the GA the more targeted the insights. However, the narrower the scope the more complex campus wide data collection and analysis become. This trade off must be considered when designing the Waste Audit and defining the campus Generation Areas. In general, as the campus diversion rate and circularity index improve, more targeted waste Generation Areas are required for targeted recommendations and subsequent improvement.

Current waste Generation Areas based on historical waste audits and waste flows at UVic are defined in Table 2. Additional Generation Areas shall be defined in the design stage of a Waste Audit, as required to continue progress towards CSAP goals and drive strategic targeted insights.

Table 2. UVic Waste Generation Areas and Definitions

<i>Generation Area Name</i>	<i>Scope and Definition</i>
<i>Academic Services</i>	All waste flows from academic buildings and/or buildings used primarily for teaching and or research (i.e. lecture, labs, library etc.)
<i>Administrative Services</i>	All waste flows from administrative and campus operations buildings or infrastructure.
<i>Residence Services</i>	All waste flows from residences and family housing.
<i>Student Society Food Services</i>	All waste flows from student society food service buildings and/or services.
<i>University Food Services</i>	All waste flows from university managed food services and/or services (i.e. COVE, mystic market, biblio café etc.)

Prior to initiating a Waste Audit, each building or piece of campus infrastructure (i.e. outdoor sort it out stations) shall be assigned to one of the defined Generation Areas. A detailed list of the buildings and their assigned Generation Area is provided in Appendix 1. This list is non-comprehensive and reflects the buildings that were included in the 2022 Waste Audit and the Generation Area they would be assigned to.

3.4 End-of-Life Waste Streams

All Waste Audit data points shall include a data attribute to identify their waste stream. In the context of this SOP, waste streams shall be defined by their end-of-life waste management practice (Table 3).

Table 3: Waste streams at UVic defined by their end-of-life management practices.

<i>Waste Stream</i>	<i>Definition</i>
<i>Landfill</i>	All waste materials generated and destined for landfill facilities
<i>Recycling</i>	All waste materials generated and destined for recycling facilities
<i>Composting</i>	All organic materials generated and destined for composting facilities
<i>Resource Recovery</i>	All materials that are reused or remanufactured as direct inputs into another product

3.5 Detailed Weight Information

Each data point shall include a variety of detailed weight information that shall be based on actual weights and not estimates. If actuals are not possible a detailed methodology behind the estimations shall be provided and clearly documented. Best practice is to record actual gross weights of each bin/bag of waste, sorting into defined categories to determine net weight by category and bin.

The defined categories (i.e., plastic, soft plastic, electronics, glass) shall be prepared as part of the Waste Audit design phase. A complete equipment list and methodology for data collection is outside the scope of this SOP but as essential component to the design stage of any Waste Audit. An example template based on the 2022 waste audit has been provided for reference (UVic Waste Audit Template).ⁱ

The defined categories shall be approved by both Facilities Management and the Office of Campus Planning and Sustainability aligned with existing waste data governance documents.

The detailed weight information shall be sufficient to ensure waste stream composition and contamination rates can be determined for each Generation Area and waste stream.

3.6 Material Flow Analysis (MFA)

Material Flow Analysis (MFA) is a central method in Industrial Ecology used to quantify the flow and stock of materials within a defined system boundary over a specified period.ⁱⁱ MFA reduces the complexity of a material-based system and applies the principle of mass balance, ensuring that all inputs, outputs, and accumulations of material are accounted for within the system. To conduct MFA a system boundary, functional unit, and system processes must be defined. Transfer coefficients can be calculated to estimate material flows and stock changes through the system. Sankey diagrams provide a visual representation of the flow quantities to present MFA results using MFA software. The data specificity derived from the MFA analysis can be leveraged to determine Generation Area specific flows diversion rates and baseline metrics (Appendix 2). Examples of MFA diagrams of UVic 2024 waste flows and be found in Appendix 3 and 4.

3.6.1 UVic System Boundary, Functional Unit and System Processes

UVic's waste system boundary shall be defined as the Gordon Head campus and the functional unit as tonnes of waste per year (t/yr) for each analysis. This is essential to measure progress year over year in a consistent and reliable way. A narrower system boundary can be defined as required for targeted efforts within a specified process. Each MFA shall clearly denote the system boundary and functional unit to ensure accurate comparability from one analysis to the next.

System process shall include the Generation Areas and waste streams. Current System processes are defined in Table 4. Future process can be defined as required by the specificity of the analysis.

Table 4. MFA System Processes

<i>System Process</i>	<i>Type</i>
<i>Academic Services</i>	Waste Generation Area
<i>Administrative Services</i>	Waste Generation Area
<i>Residence Services</i>	Waste Generation Area
<i>Student Society Food Services</i>	Waste Generation Area
<i>University Food Services</i>	Waste Generation Area
<i>Landfill</i>	Waste stream end facility
<i>Recycling</i>	Waste stream end facility
<i>Composting</i>	Waste stream end facility
<i>Resource recovery</i>	Waste stream end facility

3.7 Intensity Metrics

Intensity metrics express waste generation relative to a unit of output, rather than as an absolute total. It normalizes waste data against a denominator that reflects institutional scale, enabling fair comparison across time, campuses, or peer institutions. Intensity metrics are emerging as critical tools to assess the sustainability of waste management practices, as reflected by AASHE STARS updated waste intensity benchmarks.ⁱⁱⁱ Intensity metrics are an indicator of materials use efficiency, an emerging circular principle to quantify the sustainability impact of a system. Intensity metrics should be calculated to monitor UVic’s progress towards sustainable waste management. Current intensity metrics, their applicable Generation Area and associated benchmark and reporting body are detailed in Table 6.

Table 6: Generation Area Specific Intensity Metrics

<i>Generation Area</i>	<i>Metric</i>	<i>Benchmark (reporting body)</i>
<i>All</i>	kg waste generated / full time equivalent (FTE)	24kg / FTE (AASHE)
<i>All</i>	kg waste landfilled / FTE	AASHE
<i>All</i>	kg compost / FTE	AASHE
<i>All</i>	kg waste / building area	1.4kg / m ² (AASHE & THE IR)
<i>All</i>	Food waste / FTE	THE IR
<i>Academic services</i>	kg waste / FTE student	N/A
<i>Administrative services</i>	kg waste / FTE staff	N/A
<i>Residence services</i>	kg waste / bed count	N/A
<i>SSFS</i>	kg waste / transaction count	N/A
<i>UNFS</i>	Kg waste / transaction count	N/A

3.8 Circularity Index

Traditional waste reporting in higher education has relied on diversion rate to measure the proportion of waste diverted from landfill through recycling, composting, or recovery. While useful for tracking landfill avoidance, diversion rate treats all pathways as equally beneficial and does not capture differences in circular value, environmental impact, or financial cost.

The Circularity Index (CI) addresses these limitations by introducing a hierarchy-based, weighted approach that evaluates both the quantity and quality of materials diverted from the landfill and/or recovered for reuse. By applying a weighting factor to each end-of-life pathway according to its contribution to material retention and environmental benefit, the CI produces a single, quantitative indicator of overall circular performance. The methodology builds on

the Waste Hierarchy Index (WHI) methodology, and its weighting logic is supported by research.^{iv}

CI expands UVic's waste measurement beyond diversion, providing a more accurate reflection of how effectively materials are retained in productive use. Designed for clarity and practical application, the CI uses existing waste audit and hauler data to generate a consistent, repeatable metric that supports data-driven planning, transparent reporting, and continuous improvement under the Climate and Sustainability Action Plan (CSAP 2030).

3.8.1 Circularity Factors

The Circularity Index (CI) applies circularity factors (CFs) to each major end-of-life waste stream to represent its relative contribution to material circularity. These factors provide a relational weighting system tailored to UVic's waste streams and circular-economy objectives. The CF hierarchy reflects best practice while remaining realistic for UVic's operational context and available infrastructure within the Capital Regional District (CRD). Circularity factors are detailed in Table 7 and can be updated as required to reflect emerging regulatory requirements, industry trends, and academic understanding.

Table 7. Circularity Factors Summary

<i>Waste Stream</i>	<i>Circularity Factor (CF)</i>	<i>Circularity impact</i>
<i>Resource Recovery</i>	1.0	Highest level of circularity, achieved through reuse, repair, remanufacturing, and industrial symbiosis where waste replaces virgin materials, maximizing environmental and economic value
<i>Composting</i>	0.8	Converts organic waste into soil amendments, promoting nutrient cycling and reducing methane emissions, delivering strong biological and climate benefits.
<i>Recycling</i>	0.5	Provides moderate circular value by converting materials into secondary inputs but is constrained by contamination, energy use, and downcycling.
<i>Landfill</i>	0.0	Represents total loss of material utility and ongoing environmental impact, offering no circular value and remaining the least preferred option in UVic’s waste hierarchy.

Resource recovery represents the highest tier of UVic’s waste hierarchy because it avoids traditional disposal or recycling pathways, preserves embodied material and energy value, and creates mutual economic and environmental benefit. This approach aligns with the Climate and Sustainability Action Plan (CSAP 2030) by linking operational waste management with circular economy principles and regional resource networks to reduce both cost and impact.

At the University of Victoria, resource recovery is defined as disposing waste materials below market rate by providing them as inputs into another organizations process or product in a manner that maintains material integrity.

3.8.2 CI Result Interpretation

The CI produces a value between 0 and 100 percent, representing the overall circular performance of UVic’s waste management system. Higher percentages indicate that a larger share of total waste is managed through higher-value circular pathways such as resource recovery and composting, while lower percentages reflect continued reliance on landfill and open loop recycling (Table 8).

Table 8: Interpreting CI Results

Circularity index (CI),	Best: >75% Acceptable: 50-75% Needs attention: <50%	<ul style="list-style-type: none"> • >75% percent = most materials are reused, repurposed, or biologically cycled back into productive use • 50-75% = diversion is established but further gains can be achieved through improved reuse programs, contamination reduction, or enhanced recovery partnerships. • 50% or lower = linear disposal practices still dominate, signaling a need for targeted interventions in waste prevention, sorting, and circular procurement.
-------------------------	---	--

When tracked annually CI provides a more meaningful measure of progress than diversion rate alone, which simply captures landfill avoidance without distinguishing the relative value or cost of each pathway. CI overcomes this

limitation by weighting outcomes according to both their circular benefit and their position within UVic's operational and financial context. It aligns with the regional tipping-fee hierarchy, in which recycling is typically more expensive to the institution than composting, and composting is more costly than direct resource recovery or reuse. By integrating these economic and environmental gradients, the CI reflects not only the quality of material circulation but also the efficiency of UVic's waste system in moving toward practices that reduce both costs and impacts. This dual alignment, between circularity performance and financial sustainability, positions the CI as a more strategic, actionable metric for guiding investment, behavior change, and continuous improvement across campus operations.

3.9 Circular Waste Performance Report

A Circular Waste Performance Report shall be created annually to summarize the results from the Circular Waste Audit analysis and track UVic's progress toward the waste-related goals of the CSAP 2030.

The report shall draw on the analytical work described in this SOP, including the MFA analysis and diagrams. It should also include historical diversion rates and other key indicators that help describe UVic's waste performance over time.

The report shall assess UVic circularity with and without Yard & Garden waste to more accurately assess UVic material efficiency and waste management practices. As such two MFA diagrams shall be included, one showing total campus waste (including yard and garden waste) and another excluding it for comparison.

Results should be discussed in relation to UVic's circular waste targets:

- Total Waste (t/FTE) \leq 24 kg/FTE
- Circularity Index (CI) \geq 75 %
- Diversion Rate \geq 90 %

The report may also highlight special observations, such as changes in waste composition, audit insights, episodic waste events, or improvements in resource recovery documentation. The report shall include: a summary of findings, key metrics, MFA visuals, discussion of trends, and recommendations for the coming year.

4 Definitions and Acronyms

4.1 Definitions

Circular Economy (CE): An economic and environmental framework that prioritizes keeping materials in use for as long as possible through reuse, repair, recycling, and recovery, minimizing waste and the extraction of virgin resources.

Circular Waste: A comprehensive performance framework that measures not only the amount of waste diverted but also the circular value of material flows. It emphasizes reuse, composting, and resource recovery, advancing beyond traditional zero-waste metrics to align with circular economy principles.

Circular Waste Target: A quantitative goal that defines UVic's desired circular performance level, replacing diversion-based or "zero waste" targets. It measures how effectively campus operations retain material value and minimize waste through high-value circular pathways.

Circularity Index (CI): A weighted quantitative indicator that measures the overall circular performance of UVic's waste system by integrating both the quantity and quality of material diversion. It assigns weighting factors to end-of-life pathways (landfill, recycling, composting, resource recovery) based on their position in the waste hierarchy.

Contamination rate: the proportion of material incorrectly placed in a given waste stream that does not belong to that stream's intended end-of-life pathway. It is expressed as the percentage of non-conforming material by weight within a sample or total stream.

Episodic Waste: Non-routine waste generated from temporary or event-driven activities, including construction, renovations, move-outs, or infrastructure

renewal. Episodic waste can significantly affect annual totals but does not represent ongoing operational performance.

Functional Unit: The quantitative reference basis used in MFA to normalize data (e.g., tonnes of waste per year). It defines the scale and timeframe of analysis for consistent comparison and benchmarking.

Intensity Metric: A ratio expressing waste generation relative to an institutional activity or capacity unit (e.g., per FTE or per square metre). Used to normalize data for temporal or cross-campus comparison and to assess material efficiency.

Material Flow Analysis (MFA): A core method of industrial ecology that quantifies the flow and stock of materials within a defined system boundary. MFA supports mass balancing and visualization (e.g., Sankey diagrams) to evaluate material inputs, outputs, and changes in storage over time.

Material Stock: The accumulated mass of materials physically retained within the system boundary—such as in buildings, infrastructure, and durable goods. Stocks represent future waste flows and define long-term diversion and recovery potential.

Operational Waste: Waste generated during normal, ongoing campus operations such as teaching, research, administration, and food services. It represents the steady-state waste flow under standard institutional conditions.

Resource Recovery: A process where waste materials directly substitute virgin inputs in another product or industrial process, including reuse, refurbishment, and remanufacturing, and waste is disposed below market rate. Represents the highest level of circular value within UVic's waste hierarchy.

Sustainable Procurement: The practice of selecting goods, services, and suppliers based on their environmental and circular performance. In this methodology, procurement decisions are recognized as a key upstream driver influencing waste generation and recovery outcomes.

System Boundary: The spatial and analytical perimeter that defines what is included in the material flow system. For UVic, this typically refers to the Gordon Head campus and may be narrowed for targeted analysis of specific processes or waste streams.

System Process: A defined stage or activity within an MFA system in which materials are transformed, stored, or transported. At UVic, processes include waste Generation Areas (e.g., academic, residence, administrative) and waste stream end facilities (landfill, composting, recycling, resource recovery).

Transfer Coefficient: The ratio of material outflow from one process to the inflow from another, used in MFA to model how waste moves between processes and to quantify flow distributions.

Waste Audit: is a structured assessment conducted over standard operating days to measure typical campus waste generation. It involves collecting, sorting, and weighing samples to determine the composition and contamination rates of operational waste streams.

Waste Diversion Rate: The proportion of total waste diverted from landfill through recycling, composting, or recovery. A legacy performance indicator within waste management now complemented by the Circularity Index for greater analytical depth.

Waste Generation Area: A defined functional area on campus responsible for producing waste (e.g., Academic Services, Residence Services, Food Services). Enables targeted post-audit analysis by source.

Zero Waste: A traditional waste management framework aiming for 90 percent or greater diversion from landfill. While foundational, it does not distinguish between the quality of diversion pathways and is therefore evolving into the more comprehensive Circular Waste framework.

4.2 Acronyms

- AASHE – Association for the Advancement of Sustainability in Higher Education
- BC – British Columbia
- CE – Circular Economy
- CF – Circularity Factor
- CI – Circularity Index
- CSAP – Climate and Sustainability Action Plan
- CRD – Capital Regional District
- EEA – European Environment Agency
- EU – European Union
- FTE – Full-Time Equivalent
- FGMT – Facilities Management
- GHG – Greenhouse Gas (appears implicitly in context when discussing emissions, though not formally introduced)
- IR – Impact Rankings (Times Higher Education)
- KPI – Key Performance Indicator
- MFA – Material Flow Analysis
- OCPS – Office of Campus Planning and Sustainability
- SSFS – Student Society Food Services
- STARS – Sustainability Tracking, Assessment and Rating System (AASHE’s reporting framework)
- SOP – Standard Operating Procedure

- UVic – University of Victoria
- WHI – Waste Hierarchy Index

5 Roles and Responsibilities

The Circular Waste Audit requires coordinated delivery of defined outputs, with responsibilities shared between the Office of Campus Planning and Sustainability (OCPS) and Facilities Management (FGMT), and supported by external service providers as needed. Each party is accountable for specific deliverables to ensure that audit results are accurate, actionable, and aligned with the CSAP. A summary of these roles and responsibilities is detailed in table 8.

Table 9. Roles and Responsibilities for Circular Waste Audit

<i>Responsibility</i>	<i>Lead</i>	<i>Support</i>	<i>Description of Responsibility</i>
<i>Audit Planning and Scope Definition</i>	OCPS	FGMT	Establish the purpose, scope, and analytical framework for the Circular Waste Audit, including defining system boundaries, Generation Areas, and data requirements.
<i>Audit Logistics and Site Coordination</i>	FGMT	OCPS	Manage operational planning, site access, and coordination with custodial staff, haulers, and external service providers. Ensure collection and sorting activities are conducted safely and consistently.
<i>Data Collection and Field Audit Execution</i>	FGMT/ External	FGMT	Conduct on-site sampling, sorting, and weighing according to UVic's approved methodology. Record detailed weight data by Generation Area and waste stream for transfer to FGMT.
<i>Operational and Hauler Data Compilation</i>	FGMT	OCPS	Compile waste tonnage, invoice, and hauling data to validate audit results and support Material Flow Analysis (MFA) inputs.

***Analytical
Deliverables***

OCPS

FGMT /
External

Lead preparation of Material Flow Analysis (MFA), Circularity Index (CI), and intensity metrics and annual circularity assessment.

6 Materials and Equipment

The data materials and software equipment required to execute the analysis in this SOP are detailed in the table below.

Table 10. Required Materials and Equipment

<i>Category</i>	<i>Item</i>	<i>Description</i>
<i>Data Input</i>	Waste Audit dataset	Detailed waste composition and weight data collected by Generation Area and waste stream.
	Waste tonnage dataset	Annual waste tonnage derived from hauler and tipping data
<i>Software</i>	Microsoft Excel	Primary data management tool for cleaning, organizing, and calculating key indicators.
	Stan 2.7	Free MFA software used to construct MFA diagrams
<i>Templates</i>	2024 UVic Waste MFA Worksheet	Example calculations of MFA

7 Procedure

7.1 MFA Diagram

To create the MFA diagrams, determine the MFA Input Values and input them into STAN to create the diagram. Follow the process detailed below and refer to the example calculations in the MFA worksheet.^v The sheet name where the example calculations can be referenced and the data sources used are listed in table 10. A summary of this process is provided below:

- Determine stream specific transfer coefficients for each process defined in the system boundary.
- Use the transfer coefficient to allocate operational waste flows to each process.
- Determine the MFA Input Values by allocating episodic waste and resource recovery flows
- Duplicates the result without yard and garden waste
- Create the MFA diagrams in STAN

Table 11. MFA Calculation Examples and Data Sources

<i>MFA calculation</i>	<i>Example Calculation Sheet Name</i>	<i>Data Sources</i>
<i>Calculate transfer coefficient</i>	Transfer Coefficients	Waste audit
<i>Calculate waste flows</i>	MFA Calculations	Waste audit and waste data (actuals)
<i>input MFA flows</i>	Transfer Coefficients	Waste audit and waste data (actuals)

7.1.1 Transfer coefficients

Determine the transfer coefficient (TC) by stream (s) and Generation Area (ga).

Transfer coefficients from the 2022 waste audit are shown in appendix 5.

For each waste stream *s* and generation area *ga*:

$$TC_{s,ga} = \frac{W_{s,ga} (kg)}{W_{s,total} (kg)}$$

Where:

- $TC_{s,ga}$ = Transfer coefficient for waste stream *s* from generation area *ga* (unitless ratio)
 - $W_{s,ga} (kg)$ = Weight of waste (kg) for stream *s* from generation area *ga*
 - $W_{s,total} (kg)$ = Total waste weight (kg) for that stream across all generation areas
-
- Sum the waste generated by stream and Generation Area from the waste audit data.
 - Divide the stream specific Generation Area weight by the total weight of that stream (i.e Academic Services kg organics/ total kg organics).
 - Complete for each stream and Generation Area for a total of 15 transfer coefficients (3 end of life waste streams x 5 Generation Areas)

Example (Organics, Academic Services)

$$TC_{\text{organics, AS}} = \frac{\text{kg of organics from Academic Services}}{\text{total kg of organics}}$$

7.1.2 Process Flows

Calculate waste flows by stream and Generation Area.

- Determine total operational waste for each stream for the target year.
Operational waste = total waste generated – episodic waste
- Determine process flows by stream and Generation Areas.
Process flow = stream operational waste * stream transfer coefficient

When calculating process flows always use the most recent waste audit data to determine transfer coefficients.

7.1.3 Determine MFA Input Values

Determine the data inputs to create the MFA diagrams by allocating the episodic waste and accounting for resource recovery:

- Allocate resource recovery to the appropriate Generation Area without double counting.
- Add episodic waste to the associated Generation Area and stream.
- Create MFA input values without yard and garden waste.

29 values are required to create an MFA diagram and are shown in table 11. They include; 20 stream and Generation Area flows (4 end of life streams x 5 Generation Area), 5 input flows (one per Generation Area), 4 output flows (one per end-of-life stream)

Table 12. MFA Input Values Table

	Resource recovery	Composting	Recycling	Landfill	Input Flow
Academic					
Admin					
Residence					
Student Society Food Services					
University Food Services					
Output flow					

When creating the MFA with yard and garden waste separate the input flow of atmospheric carbon and water that makes up the yard and garden waste into a distinct flow as it does not represent raw materials coming from the economy.

7.1.4 Creating the MFA Diagram

MFA diagram shall be created by inputting the MFA Input Values into STAN 2.7, a free MFA diagram software available provided by stan2web.net.^{vi} Detailed tutorials

for utilizing STAN can be found online for free.^{vii} The MFA diagrams shall be created using the following steps, refer to tutorials as required:

1. Create a new MFA system in Stan
2. Create a process box for each process described in the system.
 - 2.1. 5x Generation Areas
 - 2.2. 4x waste stream end facility type
3. Create input flows for each Generation Area
4. Create stream specific flows between Generation Areas and end facility types.
5. Create export flows for each end facility type.
6. Calculate MFA to ensure mass balance in the system.
7. Label all flows according to their composition detailed in figure 1.
8. Export the MFA diagram from Stan







	Mixed Flow
	Resource Recovery Flow
	Composting Flow
	Recycling Flow
	Landfill Flow
	Atm. C & Water

Figure 1: Waste composition legend for MFA flows

7.2 Intensity metrics

The intensity metrics shall be calculated by dividing the relevant annual waste total by the associated unit of output/service. Refer to table 6 for the intensity metrics to be calculated.

7.3 CI Calculation

CI shall be calculated by multiplying the proportional share of each waste pathway by its CF, summing the results and multiplying by 100%. This can be expressed mathematically by the equation below with the variable inputs detailed in table 13.

$$CI = \sum S_i \times stream\ CF$$

$$CI = \left(\frac{W_l}{W_t} \times CF_l\right) + \left(\frac{W_r}{W_t} \times CF_r\right) + \left(\frac{W_c}{W_t} \times CF_c\right) + \left(\frac{W_{rr}}{W_t} \times CF_{rr}\right)$$

Table 13. CI Variable Definitions

Variable	Description	Unit
S_i	Waste stream proportional share	tonnes
W_t	Total waste generated	tonnes
W_l	Waste landfilled	tonnes
W_r	Waste recycled	tonnes
W_c	Organics composted	tonnes
W_{rr}	Waste reused or recovered	tonnes
CF_i	Assigned circularity factor	N/A

7.4 Circular Waste Performance Report Preparation

The Circular Waste Performance Report serves as UVic’s official annual summary of circular waste performance and shall inform internal planning, external reporting, and continuous improvement under CSAP 2030. Follow the procedure detailed below to prepare the Circular Waste Performance Report:

1. Compile all analytical outputs from this SOP, including:
 - a. Material Flow Analysis (MFA) data and diagrams
 - b. Circularity Index (CI) calculations
 - c. Intensity metrics
 - d. Historical diversion rates and total waste (t/FTE)
2. Summarize results in relation to UVic's circular waste targets:
 - a. Total Waste (t/FTE) \leq 24 kg/FTE
 - b. Circularity Index \geq 75 %
 - c. Diversion Rate \geq 90 %
3. Interpret findings, identifying major trends, data limitations, or observations (e.g., composition changes, episodic waste, resource recovery updates).
4. Draft the report and include:
 - a. Summary of findings
 - b. MFA diagrams (with and without yard and garden waste)
 - c. Key metrics (with and without yard and garden waste)
 - d. Discussion of trends and data quality
 - e. Recommendations for the coming year
5. Submit the draft to FGMT for review and approval prior to publication.

8 Records and Documentation

Accurate recordkeeping and documentation are essential to ensure the transparency, reproducibility, and institutional value of the Circular Waste Audit. All records created through this procedure must be stored and retained in accordance with the UVic's Waste Data Governance Framework.

8.1 Required Records

- Raw Audit Data (Excel file) – Verified dataset containing composition, contamination, and weight data organized by Generation Area and waste stream.
- Circular Waste Analysis Worksheet (Excel file) – Analytical workbook used to calculate Material Flow Analysis (MFA) input values, intensity metrics, transfer coefficients, and the Circularity Index (CI).
- Circular Waste Performance Report (PDF or Word file) – Annual report summarizing analytical results, key performance indicators, and recommendations for improving material circularity and alignment with the Climate and Sustainability Action Plan (CSAP 2030).

9 Future Directions

Future development for this SOP should focus on refining analytical depth and expanding circular scope across campus operations. This includes but is not limited to documenting episodic waste and resource recovery, defining campus material stocks, integrating circular procurement and institutionalizing circular waste targets.

9.1 Documenting episodic waste and resource recovery

Improving documentation of episodic waste and resource recovery flows is a key future direction for enhancing UVic's circular waste reporting. Distinguishing episodic from operational waste improves the accuracy and interpretability of circular performance metrics. Operational waste provides a baseline for evaluating systemic efficiency and tracking progress over time, while episodic waste can introduce temporary spikes that distort long-term trends if not separately recorded. Recording episodic activities separately allows these short-term material releases to be analyzed independently, improving the precision of MFA and CI results.

Better documentation of resource recovery flows likewise strengthens the representation of circular outcomes by verifying high-value recovery pathways and ensuring data accurately reflect both environmental and economic performance. Currently, all resource recovery flows are attributed to administrative buildings due to limited documentation of their generation sources. Enhancing consistency and completeness in these records will increase data reliability, refine audit-based indicators, and better demonstrate UVic's progress toward the waste-related goals of the Climate and Sustainability Action Plan (CSAP 2030).

9.2 Defining Campus Materials Stocks

Much of the university's material throughput is stored in long-lived assets (buildings, infrastructure, and equipment etc.) that will eventually become future waste. Incorporating stock accounting into MFA enables UVic to anticipate these deferred waste streams, prioritize materials with high recovery potential, and design interventions that extend asset lifespans and improve recoverability. This evolution from flow-based to stock-informed waste management represents a major step toward predictive, circular campus planning.

9.3 Integrating Circular Procurement

To fully operationalize circularity, UVic should integrate sustainable procurement policies and data into its waste and material flow systems. Quantifying how much of the material flow is influenced by institutional purchasing behavior versus external consumption will clarify the university's sphere of control and highlight leverage points for circular intervention. Embedding procurement metrics into MFA and CI analysis connects upstream purchasing decisions to downstream waste outcomes, illuminating how material selection, vendor contracts, and design standards determine both waste generation and recovery potential.

9.4 Institutionalizing Circular Waste Targets

Building on this integration, UVic should establish a Circular Waste Target that provides a clear, quantitative definition of circular waste performance. This target replaces traditional "zero waste" framing, which emphasizes landfill avoidance, with a circular approach that values material retention, recovery quality, and system efficiency. A quantitative circular definition enables actionable goal setting, better alignment with CSAP and regulatory trends, and transparent progress

tracking under recognized frameworks such as AASHE STARS and the Times Higher Education Impact Rankings.

Defining and adopting a Circular Waste Target represents a pivotal institutional commitment bridging the gap between aspiration and measurement. It provides UVic with a transparent, data-driven framework to monitor material performance, inform procurement and infrastructure decisions, and direct investments toward the most circular and cost-effective outcomes. A recommend quantitative circular waste definition its rational for UVic are detailed in table 9.

Table 9: UVic Quantitative Definition of Circular Waste

<i>Metric</i>	<i>Target</i>	<i>Rationale</i>
<i>Total Waste Generated (t/FTE)</i>	≤ 24 kg/FTE	Aligns with the AASHE STARS waste intensity benchmark and provides a standardized indicator of operational efficiency. Demonstrates UVic’s progress in reducing material throughput per capita and supports CSAP 2030 waste reduction and resource efficiency objectives.
<i>Circularity Index (CI)</i>	$\geq 75\%$	Responds to emerging regulatory and reporting trends emphasizing circularity over diversion. A CI above 75% indicates high-value material retention through composting, reuse, and resource recovery, aligning financial incentives with the circular economy principles and CSAP goals.
<i>Diversion Rate</i>	$\geq 90\%$	Established zero-waste target consistent with higher-education sustainability standards and long-standing waste reduction frameworks. Maintains continuity with UVic’s established zero waste commitments while serving as a transitional indicator toward circular performance metrics.

This transition from, zero waste to circular waste, and from diversion metrics to circular performance, positions UVic at the forefront of institutional sustainability practice. It aligns regulatory compliance, financial efficiency, and environmental leadership under a single coherent system, enabling the university to model how post-secondary institutions can operationalize the circular economy and achieve the dual goals of cost reduction and carbon neutrality through intelligent material stewardship.

10 Appendix

Appendix 1.

BUILDING OR INFRASTRUCTURE	GENERATION AREA
BOB WRIGHT	Academic Services
BUSINESS & ECONOMICS	Academic Services
CLEARIHUE	Academic Services
CONTINUING STUDIES	Academic Services
CUNNINGHAM	Academic Services
DAVID STRONG	Academic Services
DAVID TURPIN	Academic Services
HUT E	Academic Services
ELLIOT	Academic Services
ENGINEERING & COMPUTER SCIENCE	Academic Services
HSD	Academic Services
HUMAN & SOCIAL DEVELOPMENT	Academic Services
LIBRARY	Academic Services
MACLAURIN	Academic Services
MCKINNON	Academic Services
PETCH	Academic Services
SEDGEWICK	Academic Services
STRONG	Academic Services
TURPIN	Academic Services
BOOKSTORE	Administrative Services
CARSA	Administrative Services
UNIVERSITY CENTRE	Administrative Services
FIRST PEOPLE	Administrative Services
HEALTH & WELLNESS / TECHNOLOGY	Administrative Services
ENTERPRISE	
OUTDOOR SORTING STATION	Administrative Services
SAUNDERS	Administrative Services
UNIVERSITY CENTRE	Administrative Services
RES BUILDING 1	Residence Services
FAMILY 2	Residence Services
FAMILY 3	Residence Services
RES 14	Residence Services
RES 16	Residence Services
RES 17	Residence Services

RES 18	Residence Services
RES 2S	Residence Services
FAMILY 6	Residence Services
FAMILY 7	Residence Services
GRADUATE STUDENTS SOCIETY	Student Society Food Services
STUDENT UNION BUILDING	Student Society Food Services
BIBLIO CAFE	University Food Services
COVE	University Food Services
MAC BISTRO	University Food Services
MYSTIC MARKET	University Food Services

Appendix 2. Generation and Stream Specific Analysis Enabled by MFA

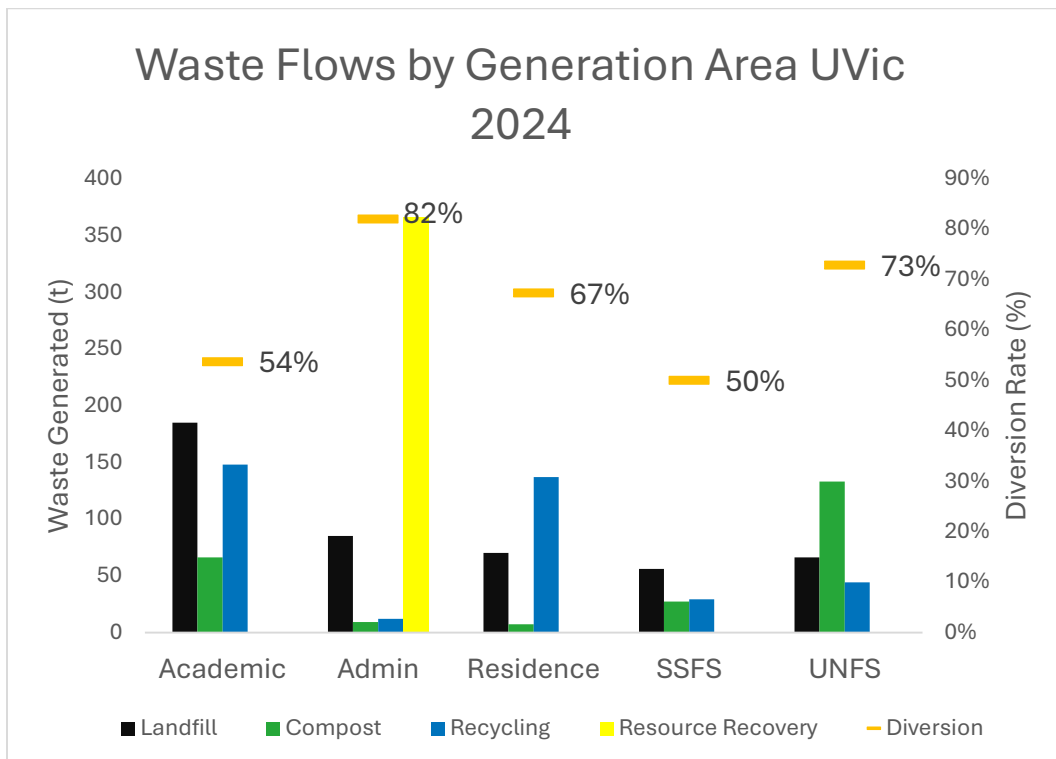

Data sources: 2024 UVic Reconciled Waste Data, 2022 Raw Waste Audit Data

Appendix 3. 2024 UVic Waste MFA without Yard and Garden Waste

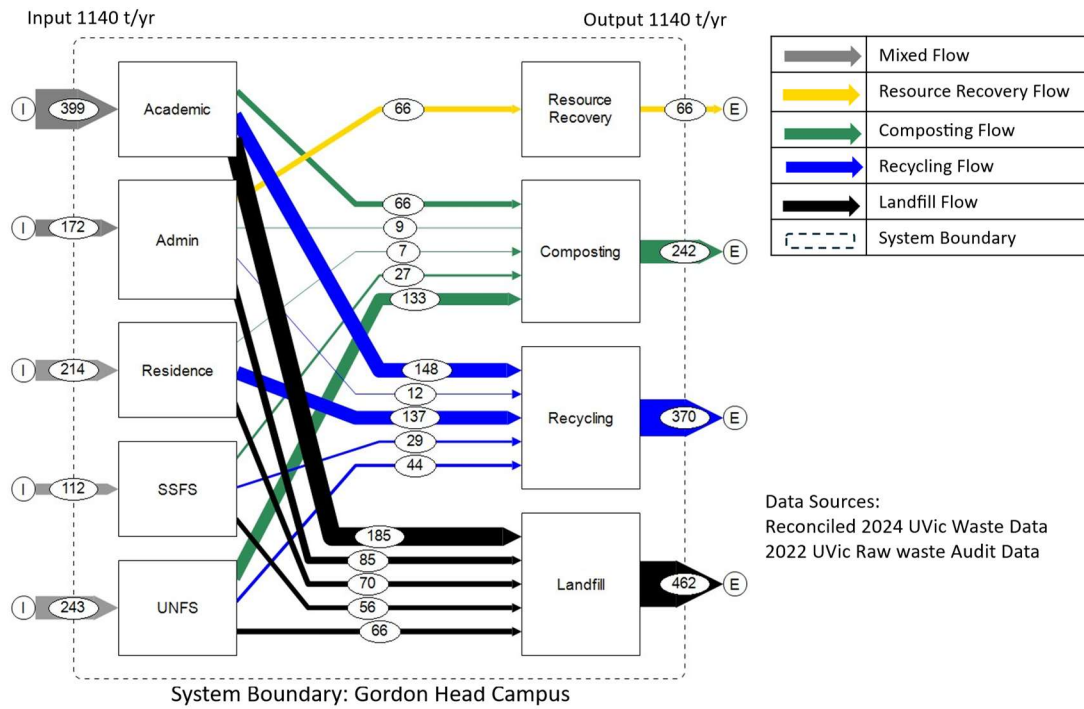

Data sources: 2024 UVic Reconciled Waste Data, 2022 Raw Waste Audit Data

Appendix 4. 2024 UVic Waste MFA with Yard and Garden Waste

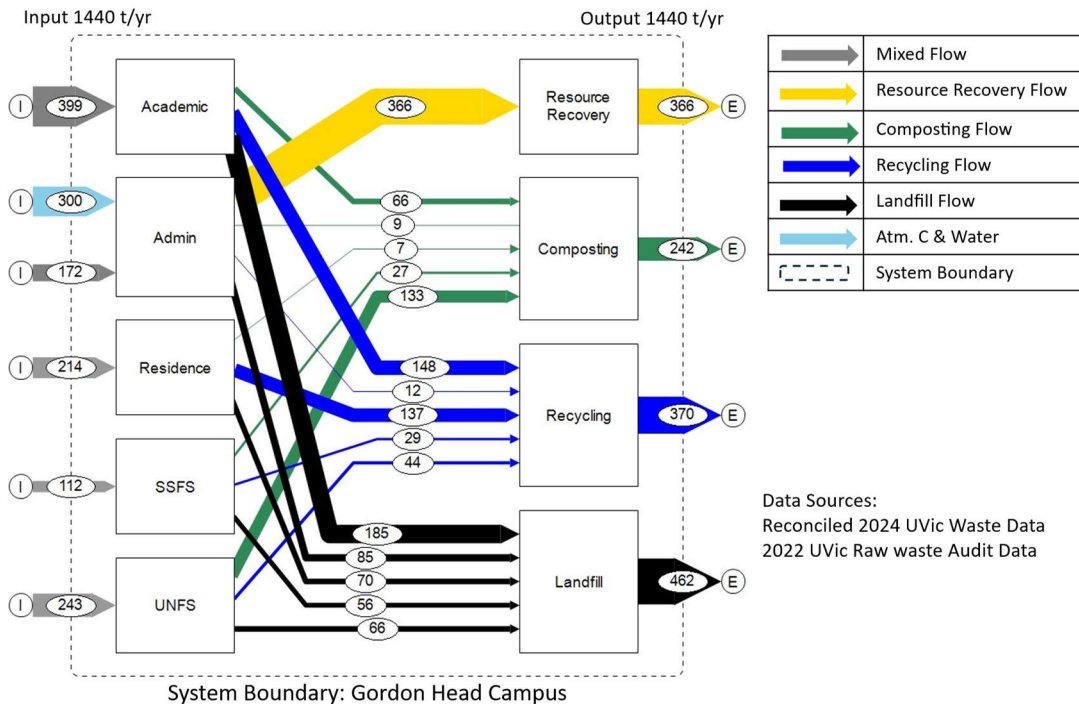

Data sources: 2024 UVic Reconciled Waste Data, 2022 Raw Waste Audit Data

Appendix 5. Transfer Coefficients from 2022 Waste Audit.

<i>Generation Areas</i>	<i>Composting</i>	<i>Recycling</i>	<i>Landfill</i>
<i>Academic</i>	0.27	0.34	0.40
<i>Admin</i>	0.04	0.18	0.19
<i>Residence</i>	0.03	0.31	0.15
<i>Student Society Food Services</i>	0.11	0.07	0.12
<i>University Food Services</i>	0.55	0.10	0.14

Data sources: 2022 Raw Waste Audit Data

11 References

11.1 Data Sources

- 2024 UVic Waste MFA Worksheet
- 2024 UVic Reconciled Waste Data
- 2022 Raw Waste Audit Data

11.2 Resources

- Climate and Sustainability Action Plan 2030 [Climate & Sustainability Action Plan 2030 - University of Victoria](#)
- Ellen Macrthur Foundation [Leading the Transition to a Circular Economy | Ellen MacArthur Foundation](#)
- National Zero Waste Council Canada [NZWC - Home](#)
- The Association for the Advancement of Sustainability in Higher Education [Home - The Association for the Advancement of Sustainability in Higher Education](#)
- THE Higher Education Impact Ranking [University Impact Rankings 2025 | Times Higher Education \(THE\)](#)

11.3 Endnotes

ⁱ Scanlon, J.D. (2024) UVic Waste Audit Template. Sustainability Scholars Program. Office of Campus Planning and Sustainability

ⁱⁱ Graedel, T. E. (2019) Material Flow Analysis from Origin to Evolution. *Environmental science & technology*. [Online] 53 (21), 12188–12196.

ⁱⁱⁱAASHE (2025) STARS Technical Manual Version 3.0.1 OP 12 Waste Generation and Recovery. The Association for the Advancement of Sustainability in Higher Education. <https://stars.aashe.org/wp-content/uploads/2025/07/STARS-Technical-Manual-Version-3.0.1.pdf>

^{iv} Pires, A., and Graça. M. (2019) “Waste Hierarchy Index: A New Tool for Evaluation of Waste Management Performance.” *Waste Management* 95: 298–305.
<https://doi.org/10.1016/j.wasman.2019.06.014>

^v Scanlon, J.D. (2024) 2024 UVic Waste MFA Worksheet. Sustainability Scholars Program. Office of Campus Planning and Sustainability.

^{vi} IWR (2012) STAN2WEB Welcome. Research Unit for Waste and Resource Management. TU Wien.
<https://www.stan2web.net>

^{vii}IWR (2021) STAN2WEB Videos. Research Unit for Waste and Resource Management. TU Wien.
<https://www.stan2web.net/support/videos>