



University
of Victoria

Adaptation of Gold Nanoparticles for Zinc-Air Battery Applications

Spencer Thomas, Chris Tremblay, Heather Buckley*
Department of Chemistry, University of Victoria
March 9, 2024

Background and Objectives

The most common renewable energy sources are intermittent and vary with the weather and time of year. Therefore, cheap and effective energy storage technologies are needed.

Zinc-air batteries (ZABs) offer a promising alternative for cheap, safe and large-scale energy storage when compared to lithium-ion batteries.

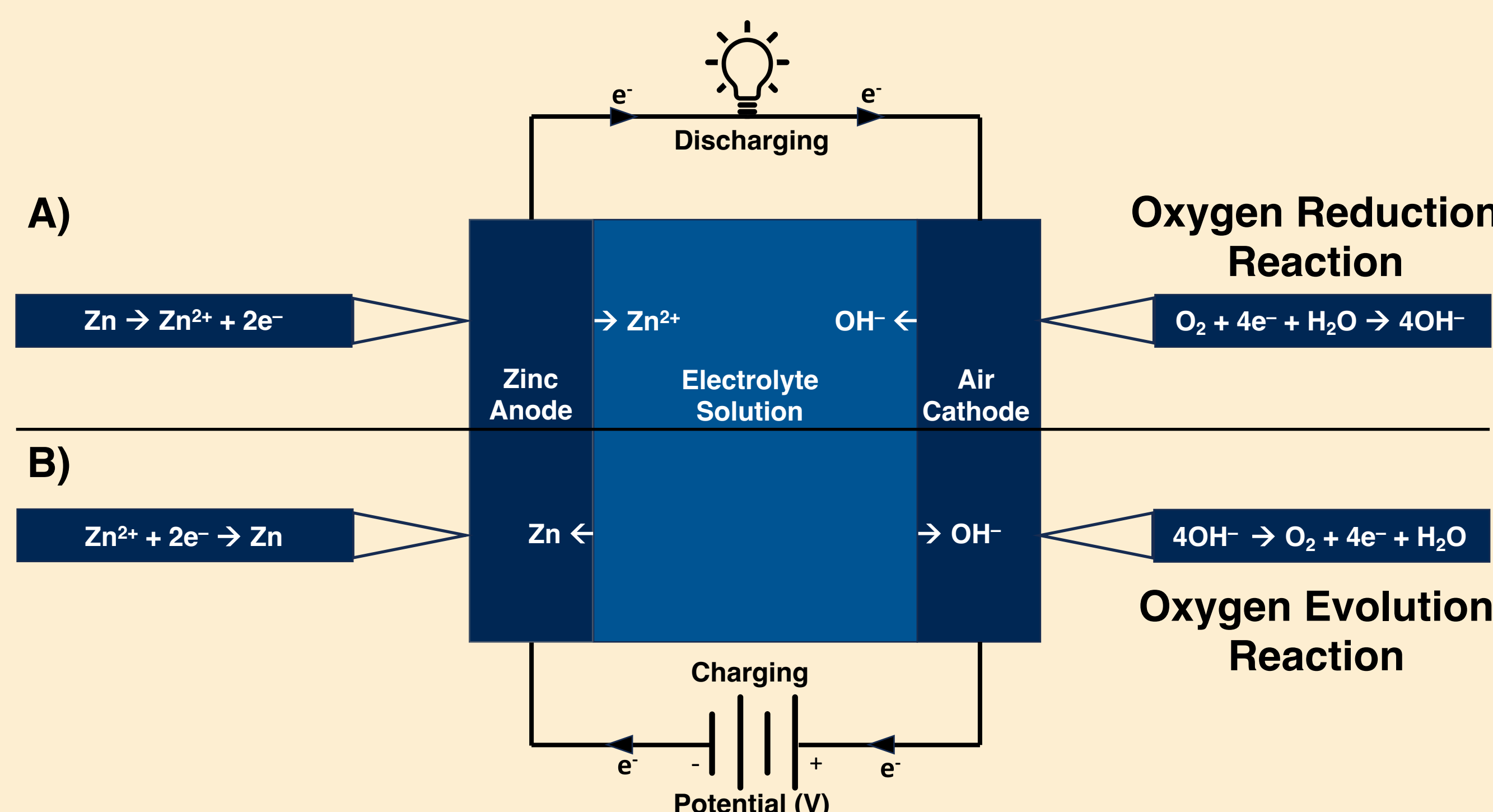

Figure 1: ZAB diagram. A) Battery in discharging state. B) Battery in charging state.

However, ZABs have several limitations, including sluggish reaction kinetics at the air cathode. The oxygen **reduction reaction (ORR)** and **oxygen evolution reaction (OER)**, the discharge and recharge cathodic reactions, require catalysts to operate at an effective rate.

Gold nanoparticles (AuNPs) are exceptional catalysts in the ORR under alkaline conditions. Unfortunately, they do not catalyze the OER.¹ However, by adding a transition metal that is active in the OER to the AuNPs, you can catalyze both the ORR and OER effectively.^{2,3}

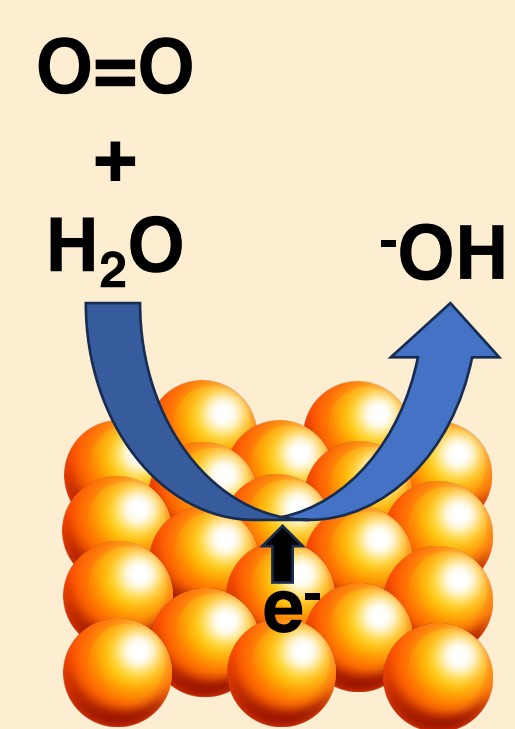

Figure 2: ORR at gold surface.

This research focuses on the synthesis, characterization and electrochemical testing of gold-copper nanoparticles (AuCuNPs) with unique cuboctahedron morphology that catalyze the ORR and OER for ZAB applications.

References

- Adžić, R. R.; Strbac, S.; Anastasijević, N. Electrocatalysis of Oxygen on Single Crystal Gold Electrodes. *Materials Chemistry and Physics* **1989**, *22* (3–4), 349–375. DOI:10.1016/0254-0584(89)90005-9.
- Hofmann, D. M.; Fairbrother, D. H.; Hamers, R. J.; Murphy, C. J. Two-Phase Synthesis of Gold-Copper Bimetallic Nanoparticles of Tunable Composition: Toward Optimized Catalytic CO₂ Reduction. *ACS Applied Nano Materials* **2019**, *2* (6), 3989–3998. DOI:10.1021/acsanm.9b00904.
- Zhou, Z.; Li, X.; Li, Q.; Zhao, Y.; Pang, H. Copper-Based Materials as Highly Active Electrocatalysts for the Oxygen Evolution Reaction. *Materials Today Chemistry* **2019**, *11*, 169–196. DOI:10.1016/j.mtchem.2018.10.008.
- Vinila, V. S.; Isac, J. Synthesis and Structural Studies of Superconducting Perovskite Gdb₂a₂ca₃cu₄o_{10.5}+δ Nanosystems. *Design, Fabrication, and Characterization of Multifunctional Nanomaterials* **2022**, 319–341. DOI:10.1016/b978-0-12-820558-7.00022-4.

Synthesis of Nanoparticles

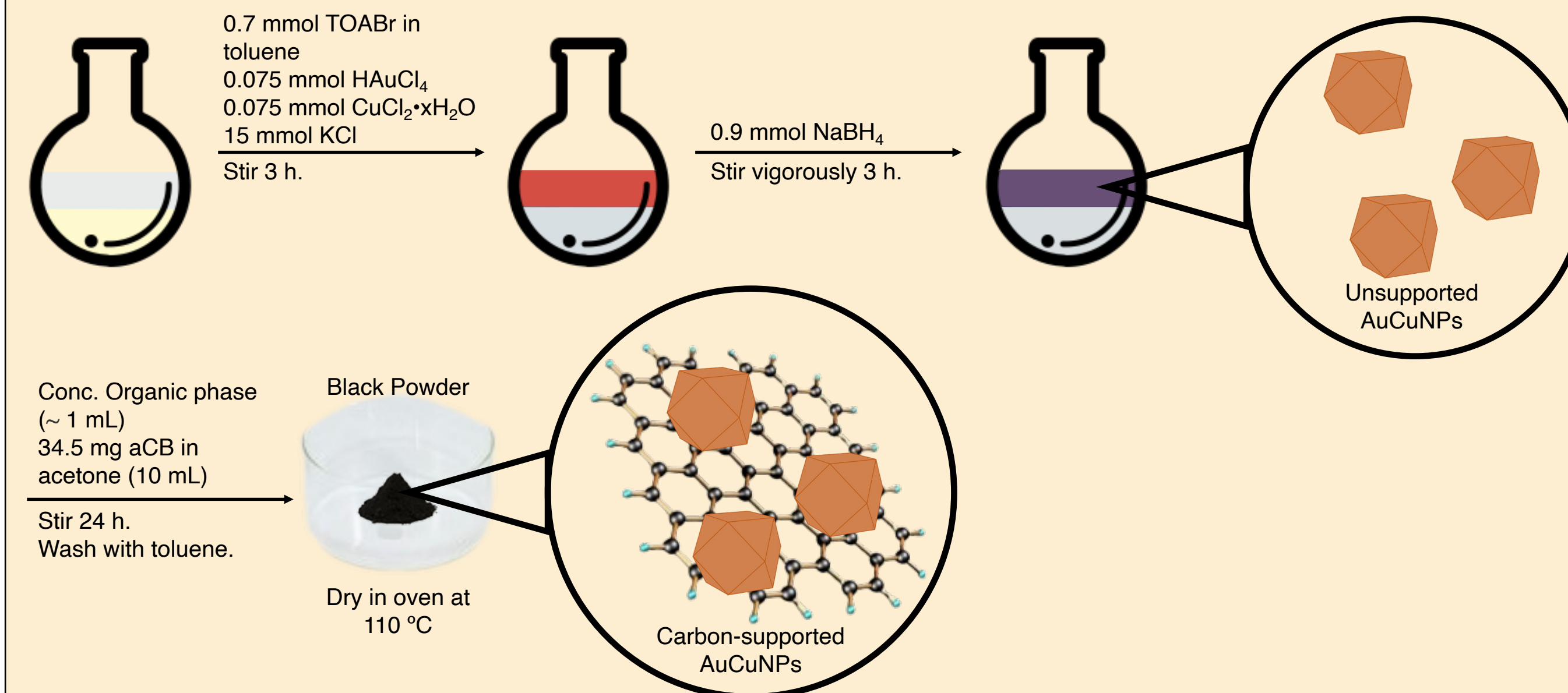

Figure 3: Reaction methods for the synthesis of AuCuNP cuboctahedrons. The bottom layer in the round bottom flasks is the aqueous layer and the top is the organic layer.

AuCuNP cuboctahedrons were synthesised on acid treated carbon black (aCB) supports using a modified Brust method with tetraoctylammonium bromide (TOABr) as a surfactant. AuNPs tend to form spheres during reduction, but TOABr protects the gold facets and allows the formation of a unique shape with different properties.

Materials Characterization

Scanning Transmission Electron Microscopy

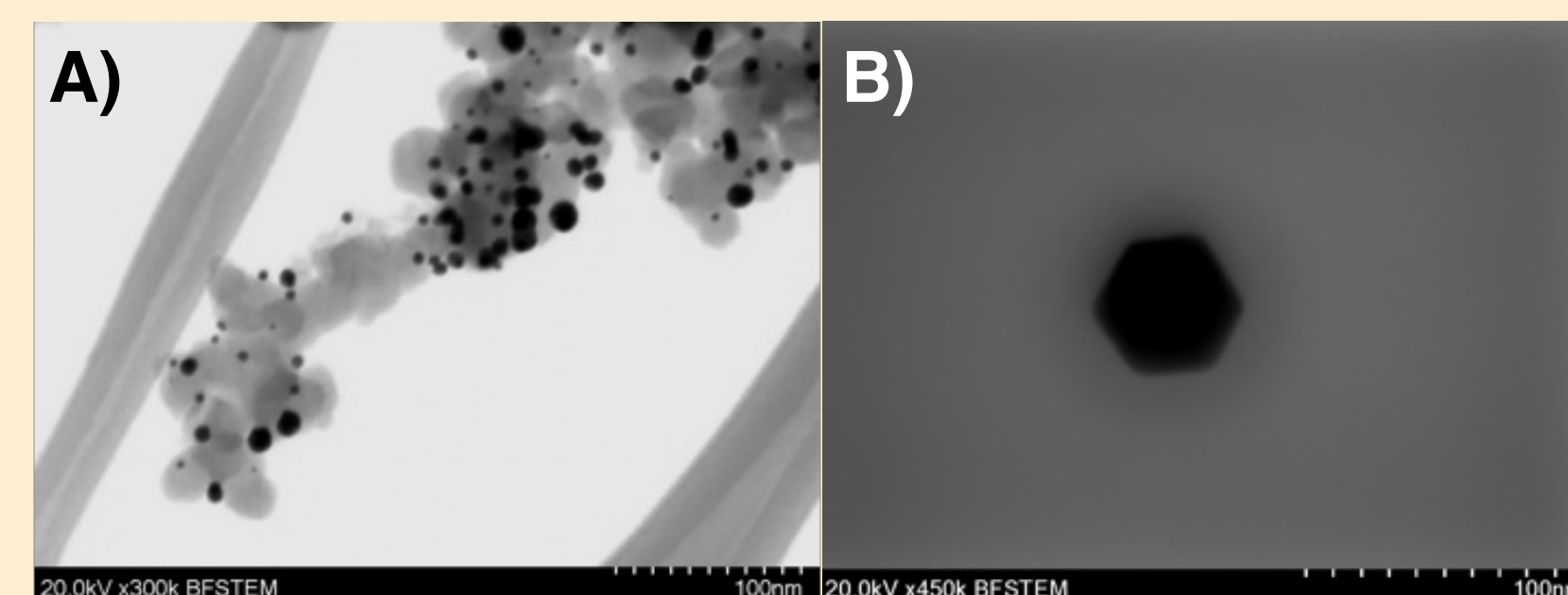

Figure 4: Experimental scanning transmission electron micrographs of AuNP cuboctahedrons. A) AuNPs supported on aCB, scale bar 100 nm. B) Unsupported AuNP showing edge morphology, scale bar 100 nm. Images captured by Chris Tremblay.

X-Ray Powder Diffraction

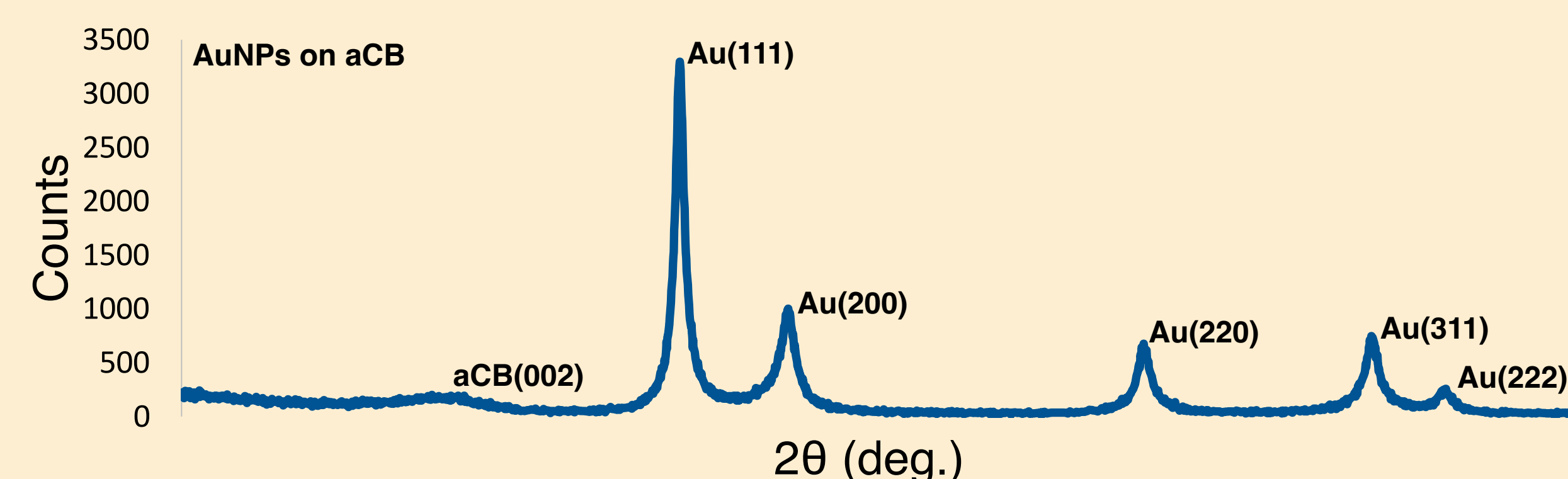

Figure 5: Experimental diffraction pattern of AuNP cuboctahedrons on carbon black.

Using the Williamson-Hall method, particle size and strain broadening can be determined by considering peak width as a function of 2θ . Normalizing to a standard with large peak broadening will be used to determine if copper is in the lattice.⁴

Electrochemistry

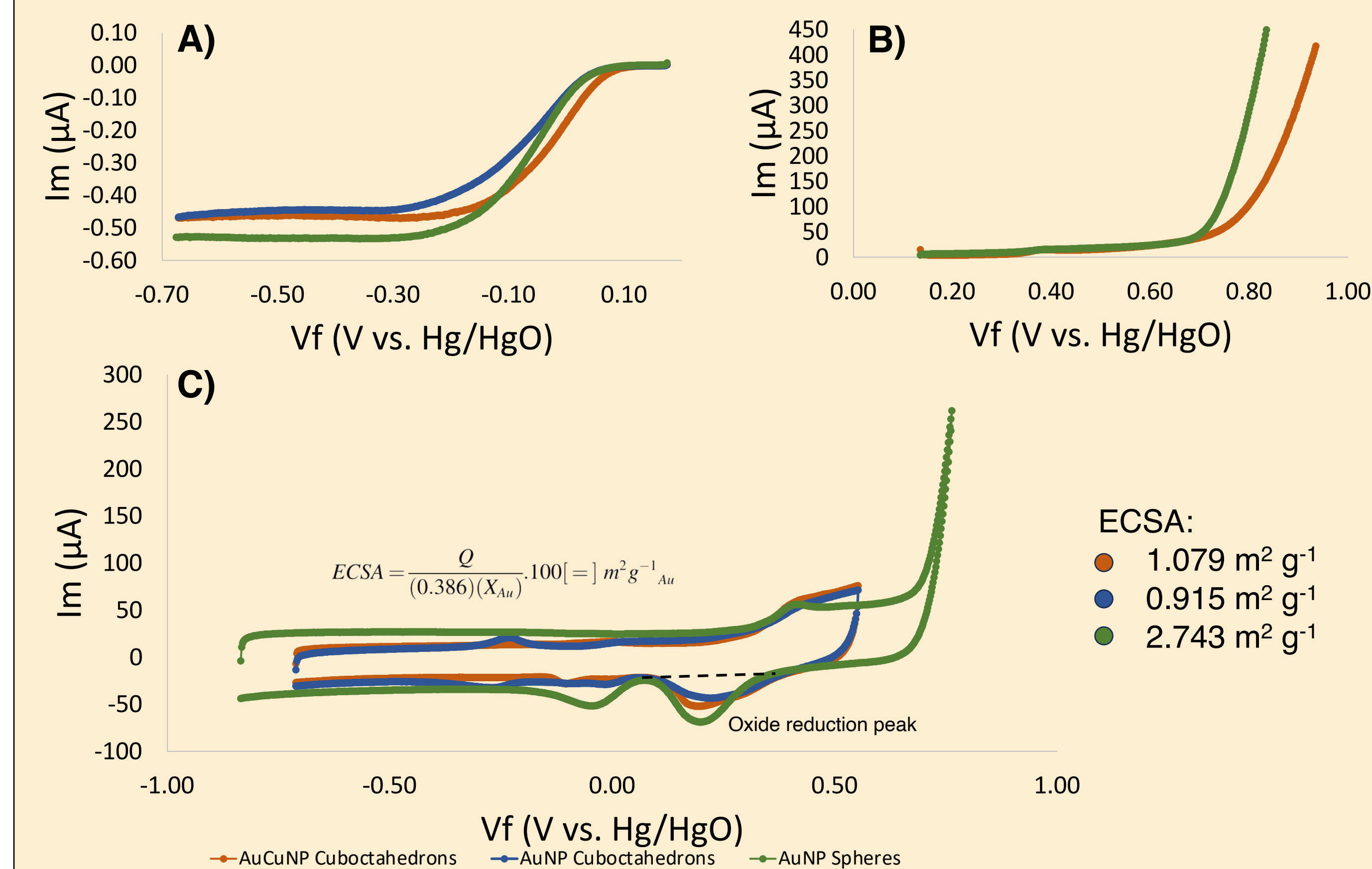

Figure 6: A) Experimental linear sweep voltammetry of ORR activity of different AuNPs. B) Experimental linear sweep voltammetry of OER activity of different AuNPs. C) Experimental cyclic voltammetry for determination of electrochemical surface area (ECSA) of different AuNPs.

Conclusion and Future Research

This work has demonstrated the bifunctional catalytic capabilities of AuCuNP cuboctahedrons in ZAB cathodic reactions. However, further optimization and testing is required to obtain efficient battery operation.

To understand the stability and corrosion mechanisms of the catalyst layer on the air cathode, identical location transmission electron microscopy (TEM) will be performed on the AuCuNPs. The catalyst layer will be put through 6000 discharge/recharge cycles, and TEM images will be taken before and after.

Further research includes the synthesis, characterization and electrochemical testing of other gold-transition metal and gold-rare earth metal nanoparticles.

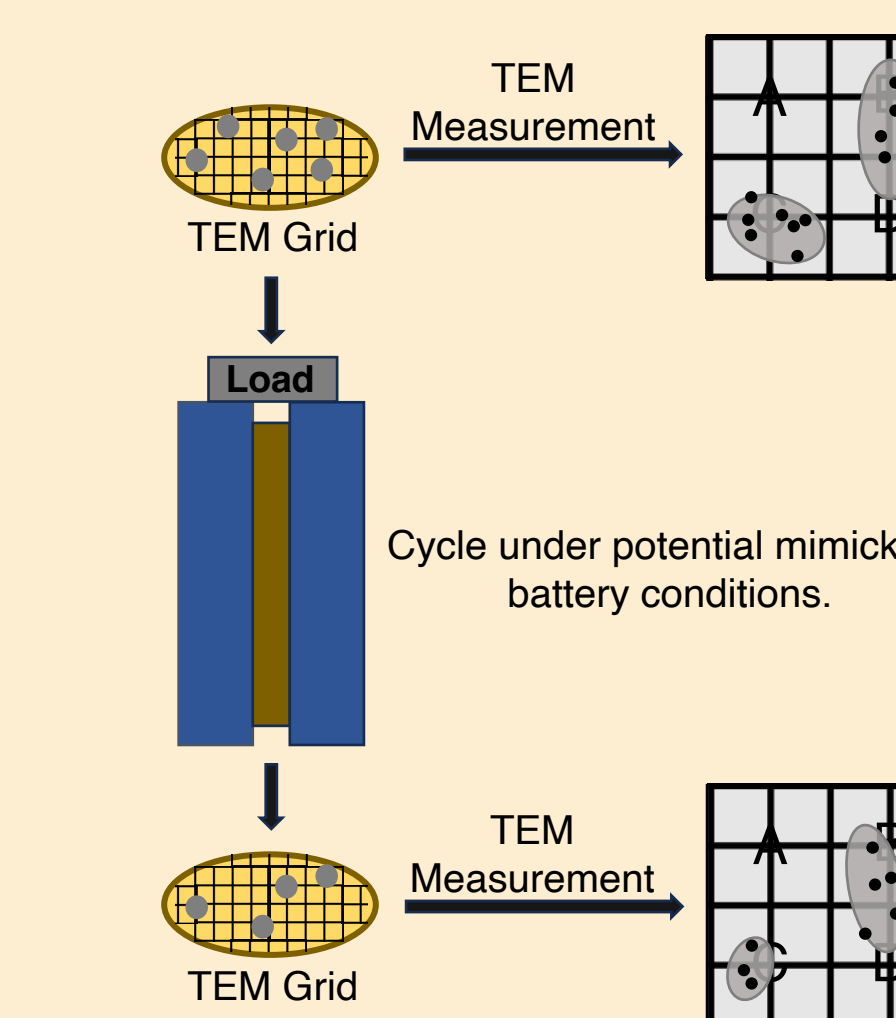

Figure 7: Identical location TEM diagram.

Acknowledgments

- This research was supported by the Jamie Cassels Undergraduate Research Awards.
- This research was supervised by Dr. Heather Buckley.
- I acknowledge the support of our industry partner XlynX.