

# **Performance Enhancements in Wireless Multihop Ad-Hoc Networks**

by

**Ahmad Ali Abdullah**

B. Sc., The Higher Institute of Electronics,  
Beni-Walid, Libya, 1991  
M. Eng., Concordia University,  
Montreal, Quebec, Canada, 1999

A Dissertation Submitted in Partial Fulfillment of the  
Requirements for the Degree of

**Doctor of Philosophy**

in the Department of Electrical and Computer Engineering

©Ahmad Ali Abdullah, 2011  
University of Victoria

All rights reserved. This dissertation may not be reproduced in whole or in part, by photocopy or other means, without the permission of the author.

# Performance Enhancements in Wireless Multihop Ad-Hoc Networks

by

**Ahmad Ali Abdullah**

B. Sc., The Higher Institute of Electronics,  
Beni-Walid, Libya, 1991  
M. Eng., Concordia University,  
Montreal, Quebec, Canada, 1999

## Supervisory Committee

---

Dr. Fayez Gebali, Co-Supervisor  
(Department of Electrical and Computer Engineering)

---

Dr. Lin Cai, Co-Supervisor  
(Department of Electrical and Computer Engineering)

---

Dr. Kui Wu, Outside Member  
(Department of Computer Science)

## Supervisory Committee

---

Dr. Fayez Gebali, Co-Supervisor  
(Department of Electrical and Computer Engineering)

---

Dr. Lin Cai, Co-Supervisor  
(Department of Electrical and Computer Engineering)

---

Dr. Kui Wu, Outside Member  
(Department of Computer Science)

## Abstract

Improving the performance of the wireless multihop ad hoc networks faces several challenges. In omni-directional antenna based solutions, the use of the RTS/CTS mechanism does not completely eliminate the hidden-terminal and exposed-terminal problems. Deafness is an additional challenge to the directional antenna based solutions.

This dissertation, first develops analytical models for quantifying the throughput and delay in wireless multihop ad hoc networks. The models consider the impact of hidden terminals using the realistic signal to interference and noise ratio model and consider random node distribution. The proposed analysis is applicable to many wireless MAC protocols and applications. The analytical results reveal several important issues. The first issue is quantifying the impact of adjusting the transmission range on the throughput and delay in wireless multihop ad hoc networks. The other issue is the hidden terminal region is closely related to the distance between

the transmitter and the receiver. Thus, it is possible to adjust the transmission range to optimize the whole network performance. These results provide important guidelines for network planning and protocol optimization in wireless multihop ad hoc networks.

Second, it proposes a new Enhanced Busy-tone Multiple Access (EBTMA) medium access control (MAC) protocol for minimizing the negative impact of both the hidden-terminal and the exposed-terminal problems. The new protocol can also enhance the reliability of packet broadcasts and multicasts which are important for many network control functions such as routing. Different from other busy-tone assisted MAC protocols, the protocol uses a non-interfering busy-tone signal in a short period of time, in order to notify all hidden terminals without blocking a large number of nodes for a long time. In addition, the proposed EBTMA protocol can co-exist with the existing 802.11 MAC protocol, so it can be incrementally deployed.

Third, it investigates how to support the directional antennas in ad hoc multihop networks for achieving higher spatial multiplexing gain and thus higher network throughput. A new MAC protocol called Dual Sensing Directional MAC (DSDMAC) protocol for wireless ad hoc networks with directional antennas is proposed. The proposed protocol differs from the existing protocols by relying on a dual sensing strategy to identify deafness, resolve the hidden-terminal problem and to avoid unnecessary blocking.

Finally, this dissertation provides important results that help for network planning and protocol optimization in wireless multihop ad hoc networks in quantifying the impact of transmission range on the throughput and the delay. The accuracy of these results has been verified with extensive discrete event simulations.

# Table of Contents

Supervisory Committee	ii
Abstract	iii
Table of Contents	v
List of Tables	ix
List of Figures	x
List of Abbreviations	xii
List of Symbols	xiv
Acknowledgment	xvi
Dedication	xvii
<b>1 Introduction</b>	<b>1</b>
1.1 Preliminaries . . . . .	2
1.1.1 Wireless Multihop Ad Hoc Networks . . . . .	2
1.1.2 Transmission Range and Sensing Range . . . . .	2
1.1.3 Hidden and Exposed Terminals . . . . .	2
1.1.4 Deafness Problem . . . . .	3
1.2 Problem Statement . . . . .	4
1.3 Contributions . . . . .	7
1.4 Dissertation Organization . . . . .	7

<b>2</b>	<b>Literature Review</b>	<b>9</b>
2.1	Performance Analysis of Wireless Multihop Ad Hoc Networks . . . . .	9
2.2	Busy-Tone-Assisted MAC Protocols for Wireless Ad Hoc Networks . . . . .	10
2.3	MAC Protocols for Ad Hoc Networks with Directional antennas . . . . .	12
2.3.1	None Busy-Tone Based Protocols . . . . .	13
2.3.2	Busy-Tone Based Protocols . . . . .	14
<b>3</b>	<b>Analysis of Random Access Multihop Wireless Networks with Hidden Terminals</b>	<b>17</b>
3.1	Introduction . . . . .	17
3.2	Network Setting and Problem Definition . . . . .	19
3.2.1	Network Setting . . . . .	19
3.2.2	Hidden-Terminal Problem . . . . .	19
3.2.3	Effect of Mobility on MAC Protocols . . . . .	21
3.3	Throughput and Delay Analyses . . . . .	21
3.3.1	Packet Transmission Probability . . . . .	22
3.3.2	Collision Probability . . . . .	22
3.3.3	Throughput Analysis . . . . .	23
3.3.4	Delay Analysis . . . . .	26
3.4	Interference from Hidden-Terminals . . . . .	28
3.5	Model Validation and Performance Evaluation . . . . .	31
3.5.1	Throughput Results . . . . .	31
3.5.2	Delay Results . . . . .	35
3.6	Chapter Summary . . . . .	39
<b>4</b>	<b>Enhanced Busy-Tone-Assisted MAC Protocol for Wireless Ad Hoc Networks</b>	<b>40</b>

4.1	Problem Definition . . . . .	42
4.1.1	The Hidden-Terminal Problem . . . . .	42
4.1.2	The Exposed-Terminal Problem . . . . .	43
4.1.3	The Busy-Tone . . . . .	44
4.1.4	Packet Broadcasting/Multicasting Problem . . . . .	44
4.2	Enhanced Busy Tone Multiple Access MAC protocol . . . . .	45
4.2.1	Broadcast and Multicast . . . . .	47
4.3	Performance Analysis . . . . .	47
4.3.1	Collision Probability . . . . .	48
4.3.2	Throughput Analysis . . . . .	48
4.3.3	Delay Analysis . . . . .	50
4.4	Performance Study by Simulation . . . . .	51
4.5	Chapter Summary . . . . .	55
<b>5</b>	<b>DSDMAC: Dual Sensing Directional MAC Protocol</b>	<b>58</b>
5.1	Problem Definition and System Model . . . . .	60
5.1.1	The Hidden and Exposed Terminals Problem . . . . .	60
5.1.2	Deafness Problem . . . . .	60
5.1.3	Locating Destination Direction . . . . .	61
5.1.4	Asymmetry-in-Gain Problem . . . . .	62
5.1.5	Antenna Model . . . . .	62
5.1.6	The Busy-Tone Signal . . . . .	64
5.2	Dual Sensing Directional MAC Protocol . . . . .	65
5.2.1	Transmitting and Receiving with DRTS/DCTS . . . . .	65
5.2.2	Directional NAV Mechanism . . . . .	67
5.2.3	Case Study and State Transitions of DSDMAC . . . . .	67
5.3	Validation Plan and Protocol Validation . . . . .	70

5.4	Performance Analysis . . . . .	73
5.4.1	Throughput Analysis . . . . .	74
5.4.2	MAC Delay Analysis . . . . .	77
5.5	Performance Evaluation . . . . .	77
5.6	Chapter Summary . . . . .	82
<b>6</b>	<b>Summary, Contributions and Future Work</b>	<b>85</b>
6.1	Dissertation Summary . . . . .	85
6.2	Contributions . . . . .	87
6.2.1	Performance Analysis of Wireless Multihop Ad Hoc Networks	87
6.2.2	Enhanced Busy-Tone-Assisted MAC Protocol for Wireless Ad Hoc Networks . . . . .	87
6.2.3	DSDMAC: Dual Sensing Directional MAC Protocol for Ad Hoc Networks with Directional Antenna . . . . .	87
6.3	Directions for Future Work . . . . .	88
6.3.1	Future Work 1 . . . . .	88
6.3.2	Future Work 2 . . . . .	88
6.3.3	Future Work 3 . . . . .	88
	<b>Bibliography</b>	<b>90</b>
<b>A</b>	<b>List of Publications</b>	<b>106</b>
A.1	Published Papers . . . . .	106
A.2	Papers Under Review . . . . .	106
<b>B</b>	<b>Implementing Random Node Distribution</b>	<b>108</b>

## List of Tables

3.1	Physical parameters. . . . .	33
3.2	Packet parameters. . . . .	33
4.1	EBTMA Physical parameters. . . . .	53
4.2	EBTMA Packet parameters. . . . .	53
5.1	SPIN verification results. . . . .	74
5.2	DSDMAC Physical parameters. . . . .	79
5.3	DSDMAC Packet parameters. . . . .	80
5.4	Aggregate CBR Multihop Throughput. . . . .	82

## List of Figures

1.1	Hidden and Exposed terminals. . . . .	3
1.2	Deafness Problems. . . . .	4
1.3	Hidden- and Exposed-Terminals Problems. . . . .	4
3.1	Illustration of hidden-terminal area. . . . .	20
3.2	Packet transmission: (a) a successful packet transmission, (b) a collision during RTS period, (c) a collision during CTS caused by hidden-terminals. . . . .	24
3.3	Packet transmission, collision and vulnerable period durations: $T_s$ , $T_{cx}$ , $T_{ch}$ and $v$ when RTS/CTS is not used. . . . .	25
3.4	Transmission attempts rounds. . . . .	27
3.5	The SINR as a function of source-destination distance $r$ for a multiple of interfering nodes. . . . .	29
3.6	Calculating hidden area for the case when the SINR is considered. . .	30
3.7	A random snapshot of node distribution in simulations. The area represented by the square in the middle includes nodes under test. . .	32
3.8	Per-hop throughput: analysis versus simulation. . . . .	34
3.9	The Collision probability $p$ versus $R$ . . . . .	35
3.10	Per-hop throughput versus transmission range ( $R$ ) for different values of node densities ( $\lambda$ ). . . . .	36
3.11	Per-hop delay: analysis versus simulation. . . . .	37
3.12	Per-hop delay versus transmission range ( $R$ ) for different values of node densities ( $\lambda$ ). . . . .	38
4.1	Busy-tone and hidden-terminals areas. . . . .	43

4.2	Packet transmission using EBTMA protocol. . . . .	46
4.3	A randomly picked snapshot from simulation runs showing node distribution in the wireless network. . . . .	52
4.4	Per-hop throughput: analysis versus simulation. . . . .	54
4.5	The shape and the peak position of the throughput. . . . .	55
4.6	Per-hop Delay. . . . .	56
5.1	Directional antenna problems: (a) Hidden terminals. (b) Deafness. . .	61
5.2	Antenna pattern: (a) Beam solid angle $\Omega_A$ . (b) Antenna power pattern.	63
5.3	Directional antenna model: (a) Antenna sectors. (b) Omni-directional function. (c) Selecting a specific sector. . . . .	64
5.4	Busy-Tone signal patterns. . . . .	64
5.5	DNAV setting. . . . .	67
5.6	Case study. . . . .	68
5.7	DSDMAC: DRTS/DCTS/DDATA/DACK and BT setting. . . . .	69
5.8	DSDMAC system state transition diagram. . . . .	71
5.9	A sample network used for validation. . . . .	72
5.10	A randomly picked snapshot from simulation runs showing node distribution in the wireless network. . . . .	78
5.11	Per-hop throughput, using 1, 4, 8 and 16 antenna sectors. Lines: analytical results; error bars: 95% confidence intervals of simulation results. . . . .	80
5.12	Collision probabilities, analysis results. . . . .	81
5.13	MAC delay with 1, 4, 8 and 16 antenna sectors. Lines: analysis results; error bars: 95% confidence intervals of simulation results. . . . .	83

## List of Abbreviations

AP	Access Point
ACK	Acknowledgment
BSS	Basic Service Set
BTMA	Busy Tone Multiple Access
CA	Collision Avoidance
CSMA	Carrier Sense Multiple Access
CSMA/CA	CSMA with Collision Avoidance
CTS	Clear-To-Send
CW	Contention Window
DACK	Directional ACK
DBTMA	Dual Busy Tone Multiple Access
DCF	Distributed Coordination Function
DCTS	Directional CTS
DDATA	Directional Data
DNAV	Directional NAV
DRTS	Directional RTS
DSDMAC	Dual Sensing Directional MAC protocol
MAC	Medium Access Control
MACA	Multiple Access Collision Avoidance
MACAW	Multiple Access Collision Avoidance protocol for Wireless LANs
MANET	Mobile Ad-hoc Network
MMAC	Multichannel MAC
NAV	Network Allocation Vector
OCTS	Omnidirectional CTS
ORTS	Omnidirectional RTS

PCF	Point Coordination Function
QoS	Quality-of-Service
RTS	Request for RTS
RTS	Request-To-Send
SNR	Signal to Noise Ratio
WLAN	Wireless Local Area Network

## List of Symbols

$\lambda$	Network node density
$\delta$	Wireless signal propagation delay
$A_H$	Hidden-terminal area
$A_h$	Expected hidden-terminal area
$A_x$	The intersection area between the source and the destination nodes
$ACK$	ACK packet time
$a$	The probability of node transmission at a given time slot
$C_h$	The event of collision by one or more nodes within $A_h$ area
$C_x$	The event of collision by one or more nodes within $A_x$ area
$CTS$	CTS packet time
$CW$	Contention window size
$DATA$	Payload duration time
$DIFS$	DIFS time
$H$	MAC header
$m$	Maximum backoff stages
$n_a$	Average successful attempts
$p$	Collision probability
$P$	PHY header
$p_{ch}$	The probability of a collision given $A_h$ area
$p_{cx}$	The probability of a collision given $A_x$ area
$P_{idle}$	Channel idle probability
$R$	Transmission range
$RTS$	RTS packet time
$r$	Source-destination distance
$SIFS$	SIFS time

$T$	Time step
$Th$	Node Throughput
$T_{ch}$	Collision time wasted by hidden-terminals
$T_{cx}$	Collision time during RTS packet transmission
$T_s$	Average successful transmission time
$t_c$	Collision time
$t_i$	Idle time
$t_o$	Time used by other users
$t_s$	Successful transmission time
$v$	The vulnerable period at which a collision may occur
$W$	Average waiting time

## Acknowledgment

All praise to Allah the Almighty who has given me the knowledge, patience, and perseverance to finish my Ph.D. dissertation. I am extremely grateful to my supervisors Dr. Fayez Gebali and Dr. Lin Cai for their continuous guidance, support, and patience during my Ph.D. study at the University of Victoria. I would like to thank my supervisory committee, Dr. Kui Wu, Department of Computer Science and the external examiner Dr. Mohammed S. Elmusrati, University of Vaasa, Finland for making my dissertation complete. I would like to thank the Libyan government for their financial support during my Ph.D study. I would like to thank my parents, brothers, and sisters for their support. I also would like to thank my wife and kids for their support and patience.

*Ahmad Ali Abdullah, Victoria, BC, Canada*

## Dedication

*To my parents, brothers and sisters. To my wife and kids.*

# Chapter 1

## Introduction

The rapid increase of the number of wireless users and the high demand on increasing the performance of wireless networks require a better management of the wireless resources. In contention-based Medium Access Control (MAC) protocols, such as the Carrier Sense Multiple Access (CSMA) protocol, each wireless node senses the activity of the wireless channel and waits for a chance to send. When the density of the wireless nodes increases, the nodes may suffer from longer access delay and higher collision probability [1–3]. Although the collision probability can be reduced with Collision Avoidance (CA), the collisions may arise from the hidden-terminals. These hidden-terminals are usually located beyond the transmission range of a transmitting node and within the interference range of a receiving node. This dissertation addresses the hidden-terminal and exposed-terminal problems and suggests solutions. In addition, it discusses applying the directional antennas for achieving a higher spatial multiplexing gain and thus higher network throughput.

## 1.1 Preliminaries

This section provides brief preliminaries to some important concepts and terms related to this dissertation.

### 1.1.1 Wireless Multihop Ad Hoc Networks

A wireless multihop ad hoc networks consists of decentralized wireless nodes connected to each other without assistance of a centralized access point. Some or all of these nodes run a routing protocol that allows them to forward packets from one node to another in order to reach distant nodes.

### 1.1.2 Transmission Range and Sensing Range

The transmission range is defined as the maximum distance at which the received signal power is above a certain threshold value to be successfully received and decoded. In other word, as in [4],

$$P_r(d) = P_t G_l \left( \frac{\lambda_c}{4\pi d} \right)^\gamma \geq P_{Threshold} \quad (1.1)$$

where  $P_r(d)$  is the received signal power at  $d$ ,  $d$  is the distance between the source and the destination nodes,  $P_t$  is the transmitted signal power,  $G_l$  is the product of the transmit and receive antenna gain,  $\lambda_c$  is the carrier signal's wavelength and  $\gamma$  is the path loss exponent. The sensing range on the other hand is the distance at which the signal can be sensed but not necessarily be decoded.

### 1.1.3 Hidden and Exposed Terminals

Hidden-terminal problem was first mentioned by Tobagi and Kleinrock in [5]. This problem arises from nodes that are located within the sensing region of the intended destination and off-range of the source node. In Fig. 1.1, node  $S$  is the source node

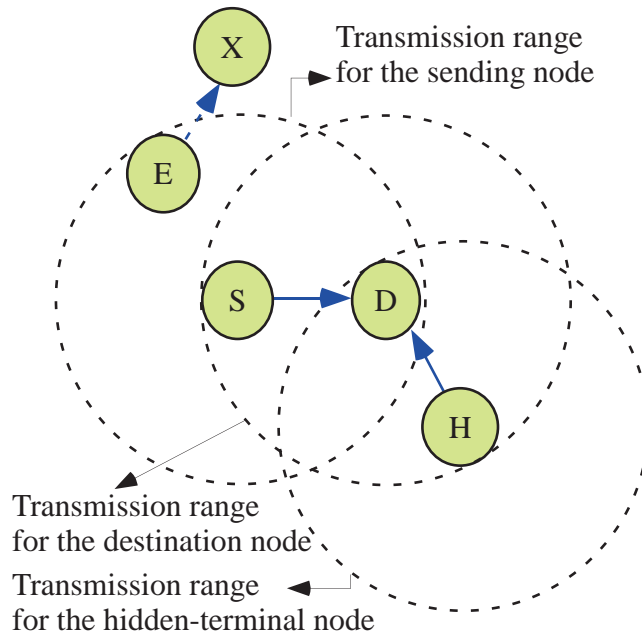

Figure 1.1: Hidden and Exposed terminals.

and node  $D$  is the destination node. Node  $H$ , the hidden-terminal, is out of node  $S$ 's transmission range but its transmission can interfere at the destination node  $D$ . The exposed-terminal on the other hand is a node that is blocked from transmission while its transmitted signal does not interfere with the source node's transmitted signal at the destination node. The transmission from node  $E$  to node  $X$  for example, will not cause a collision at node  $D$ . However, as  $E$  sense the transmission of  $S$ , it will defer its transmission till the end of  $S$ 's transmission which will lead to the exposed-terminal problem.

#### 1.1.4 Deafness Problem

Deafness is a problem that appears in a wireless network when using directional antennas. It happens when a wireless node fails to communicate to its intended destination because its destination is transmitting to or receiving from a different

direction. For example, node  $X$  in Fig. 1.2 is trying to communicate with node  $S$  which is transmitting toward the direction of node  $D$ . Fig. 1.3 shows the packet

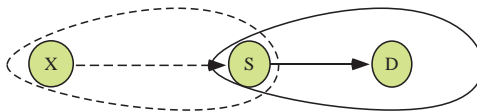

Figure 1.2: Deafness Problems.

exchange sequence between  $S$  and  $D$ . As shown in the figure, node  $X$  starts its transmission to  $S$  before the end of the transmission between  $S$  and  $D$ . As  $X$  fails to receive an acknowledgment from  $S$ ,  $X$  will double its backoff time as it would conclude a collision has occurred and hence it wastes the channel time.

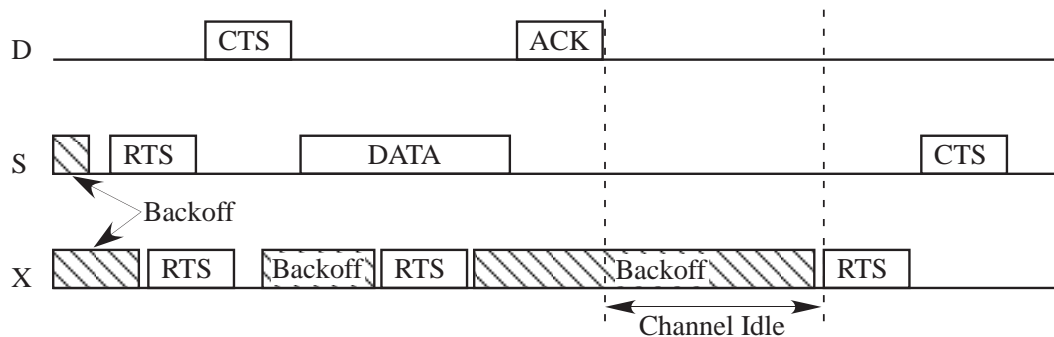

Figure 1.3: Hidden- and Exposed-Terminals Problems.

## 1.2 Problem Statement

This dissertation focuses on the performance issues of wireless multihop ad hoc networks. It provides analytical models that can be used to quantify the throughput and delay in such networks. It also provides solutions to some problems such as hidden-terminal and exposed-terminal problems. Furthermore, it provides a solution

to directional MAC protocol design problems such as dealing with the deafness and hidden/exposed -terminals problems.

In order to understand the performance of wireless multihop ad hoc networks and to optimize the design of their protocols, an accurate analytical model is required. The analysis for random access multihop networks is challenging due to the random contention among users and the existence of the hidden-terminals. In the literature, the link throughput in wireless multihop ad hoc networks has been investigated mainly by simulations or by approximated models. In addition, the MAC layer delay has not yet been studied analytically. This dissertation presents an analytical model to quantify the MAC performance in both throughput and delay in multihop ad hoc networks considering the hidden terminal problem. The model considers a random distribution for the node locations within a network area. The proposed analytical framework can be extended to analyze many random access MAC protocols.

How to overcome the hidden-terminal problem has been a very active research topic. However, most of the existing solutions can cause a very large area of blocked wireless nodes. For example, with the Busy-Tone Multiple Access (BTMA) protocol proposed by Tobagi and Kleinrock [5], nodes collaboratively transmit busy-tone signals to a region covering twice of the data transmission range in order to reach all hidden-terminals. The scheme was successful in reducing collisions due to hidden-terminals; however, it increases the number of unnecessarily blocked nodes, which leads to the exposed-terminal problem. Although there are other variations that managed to reduce the blocking areas, they were not able to effectively mitigate the hidden-terminal problem or in some cases failed to handle packet broadcasting/multicasting. This dissertation proposes an enhanced busy-tone-assisted MAC protocol that deals with both the hidden-terminal and the exposed-terminal problems. Different from the previous solutions, where the busy-tone signal remains active for the whole duration of transmitting a data packet, the proposed

protocol will let the busy-tone signal active for a very short period of time (only during the transmission of the RTS packet). This will help in solving the hidden-terminal problem without unnecessarily blocking a large number of wireless nodes for a lengthy duration.

Using directional antennas, higher antenna gain can be achieved which results in higher data rate, larger transmission range and/or lower transmission power. There are many applications using directional antennas. Vehicular networks for example is a natural application since the vehicular traffic usually follows a straight line. When used in a network, directional antennas can reduce the number of blocked wireless nodes and allow more communications to take place concurrently. As a result, the throughput and the delay of the wireless network are improved thanks to the higher spatial reuse. However, effective MAC protocols to support directional antenna faces several challenges. Particularly, the hidden-terminal, exposed terminal and deafness problems severely affect the throughput and delay performance of the network. Failed transmissions due to deafness might be treated as collisions by the source node. Even worse, it may also lead the source node to conclude that the destination node is unreachable which severely affects the performance of the higher layer protocols. There are other problems that arise when applying some of the proposed solutions in the literature, such as the asymmetry-in-gain problem [6] and the exposed-terminal problem which are discussed in more details in chapter 5. This dissertation proposes a Dual Sensing Directional MAC protocol (DSDMAC) for networks with directional antennas. The protocol helps to improve the throughput and delay performance of the wireless networks by minimizing the negative effect of the hidden-terminal, exposed-terminal and deafness problems. The protocol uses non-interfering out-of-band busy-tone signal combined with sensing the activity on the actual data channel to identify deafness situations and to avoid unnecessary blocking. In addition, the protocol avoids the asymmetry-in-gain problem introduced by other solutions.

### 1.3 Contributions

Through this research work, several contributions have been achieved. Among these contributions are:

1. Developing analytical models that allows quantifying the throughput and the delay in wireless multihop ad hoc networks. The models considers the hidden-terminal problem analysis for networks with randomly distributed wireless nodes.
2. Proposing an enhanced busy-tone-assisted MAC protocol for wireless ad hoc networks to overcome the hidden-terminal and the exposed-terminal problems.
3. Proposing a new MAC protocol for wireless networks with directional antennas. The new protocol has eliminated the deafness and hidden-terminal problems. It has also reduced the exposed-terminal problem and can outperform the state-of-art similar class of protocols.

### 1.4 Dissertation Organization

The rest of this dissertation is organized as follows.

In Chapter 2, we give some literature review for the performance analysis of the wireless multihop ad hoc networks. It then reviews the busy-tone-assisted solutions that are proposed for overcoming the hidden-terminal problem. Finally, it reviews the MAC protocols for ad hoc networks with directional antennas.

Chapter 3 provides analytical models for the throughput and the delay in the wireless multihop ad hoc networks. The chapter has also revealed some very important results that can help in network planning and protocol optimization.

In Chapter 4, a new enhanced busy-tone-assisted MAC protocol for wireless ad hoc networks is presented. The new MAC protocol has minimized the negative impact of both the hidden-terminal and the exposed-terminal problems and it has achieved better performance results.

Chapter 5 extends to another alternative and explores the wireless MAC protocols with directional antennas. It proposes a new directional MAC protocol called *Dual Sensing Directional MAC Protocol (DSDMAC)*. The new protocol can help in achieving a higher spatial multiplexing gain and a higher network throughput. It outperforms the existing state-of-art similar class of protocols by eliminating the deafness problem and minimizing unnecessary transmission blocking.

Finally, Chapter 6 summarizes the dissertation and lists the contributions made out of this dissertation. The chapter also discusses some directions for future work.

## Chapter 2

### Literature Review

This chapter reviews previous work related to this dissertation, including performance modeling of wireless multihop ad hoc networks in presence of hidden-terminals, busy-tone MAC assisted protocols and directional antennas protocols.

This chapter is organized as follows. We first review the performance analysis in wireless multihop ad hoc networks in Section 2.1. In Section 2.2, we review the busy-tone-assisted MAC protocols for wireless ad hoc networks. In Section 2.3, the MAC protocols for ad hoc networks with directional antennas are reviewed.

#### 2.1 Performance Analysis of Wireless Multihop Ad Hoc Networks

In the literature, the throughput in wireless multihop ad hoc networks has been investigated mainly by simulations or by some approximate models. Bianchi [7] and many others following works [5, 8–16] have studied the performance of single-hop wireless networks with random-access MAC protocols, however, none of them has included the hidden-terminal problem in their analytical models.

Wang and Garcia-Luna-Aceves [2] provided a simple analytical model to derive the saturation throughput of collision avoidance protocols in multihop ad hoc networks, given the transmission probability for a node. They assumed a two-dimensional *Poisson* distribution for node locations. The backoff behavior and the channel busy status was simplified into a limiting probability. As the transmission probability is difficult to set in experiments or simulations, the analytical results are difficult to verify.

Alizadeh-Shabdiz and Subramaniam [17] presented approximate analytical models for the throughput performance of a single-hop and a multihop ad hoc networks. They assumed saturated and non-saturated traffic loads. They also assumed a pre-backoff algorithm and a pre-knowledge of the neighbors of each node (a predetermined nodes distribution). The work was focusing on covering both saturated and non-saturated traffic loads rather than the accuracy of their model which make the results obtained by their models approximate.

There are also some other attempts to quantify both throughput and delay in multihop networks with random node deployment found in [18–44]. These models have not been verified by simulation. Motivated to develop accurate analytical modules, in Chapter 3, we will present our analysis and their simulation verifications.

## **2.2 Busy-Tone-Assisted MAC Protocols for Wireless Ad Hoc Networks**

The existing multihop MAC protocols can be classified into three categories: non busy-tone solutions, single busy-tone solutions and dual busy-tone solutions. The RTS/CTS mechanism is the popular non busy-tone solution to solve the hidden terminal problem. However, it still has long vulnerable period to collisions (this will be explained in more details in later chapters) and cannot be used for

broadcasting/multicasting. The multiple access collision avoidance protocol (MACA) proposed by Karn [45] was based on the RTS/CTS mechanism. Other non busy-tone based mechanisms are found in [46, 47]. They suggested to extend the sensing range of the wireless nodes over the transmission range in order to avoid hidden-terminal collisions and improve the aggregated throughput of multihop ad hoc networks. Nevertheless, these solutions typically cause a larger number of nodes to be blocked since each node contends for the wireless channel with all other nodes within its sensing range.

The earliest busy-tone based solution to overcome the hidden-terminal problem was proposed by Tobagi and Kleinrock [5]. They proposed a protocol called Busy-Tone Multiple Access (BTMA), which uses two split channels: the data channel and the control channel. While the data channel is used to transmit data packets, the control channel is used to transmit a busy-tone signal. Once a wireless node senses no busy-tone in the control channel and it has a packet to send, it turns on its busy-tone signal and starts its data transmission. All other nodes that sense an activity on the data channel will also respond by turning on their busy-tone signal. This will allow nodes within the range of the source node to be notified within one time step (the time step in this context is equal to the signal propagation delay). It will also allow all the other nodes that are located within the circular area beyond the transmission range and up to twice of the transmission range to be notified within roughly two time steps. The protocol was able to mitigate the hidden-terminal problem; however, more exposed-terminals were introduced. On the other hand, because each wireless node which senses a data packet on the data channel (including the destination node) should transmit a busy-tone signal, an additional signal filters are required in order to filter the transmitted busy-tone from the actual data signal being received.

Deng and Haas [48] proposed an extension to the BTMA protocol which is called Dual BTMA (DBTMA). Similar to the BTMA, the DBTMA uses both the data

and control channels. The control channel is responsible for transmitting the control packets such as RTS, CTS and ACK. In addition, there are two distinctive busy-tones: transmitter's busy-tone ( $BT_t$ ) and receiver's busy-tone ( $BT_r$ ). Once a node senses no  $BT_r$  and has data packets to send, it starts by sending its RTS packet on the control channel. Once the destination node receives the RTS packet, it replies with a CTS packet followed by turning on its  $BT_r$  on the control channel. The source node then starts its data transmission and turns on its  $BT_t$  on the control channel. While this protocol has an advantage of reducing exposed-terminals, hidden-terminals were not eliminated. In addition, it also requires that the receiving node should transmit a  $BT_r$  while it receives data packets. Wang and Zhuang [49] also used the  $BT_r$  in their proposed solution. Since the network allocation vector (NAV) does the same function as that by the  $BT_r$ , the  $BT_r$  is redundant.

Using busy tone to improve the reliability of broadcast transmissions and TCP performance was proposed in [50, 51]. But their busy tone channel needs to transmit messages instead of sine waves, so the solution requires higher power consumption and is more complex. Other busy-tone based solutions are also found in [52–65].

Different from the previous approaches, in Chapter 4, we will present our enhanced busy-tone-assisted MAC protocol for wireless ad hoc networks.

## 2.3 MAC Protocols for Ad Hoc Networks with Directional antennas

Random-access based MAC protocol design and analysis for ad hoc networks is a challenging problem and it has attracted extensive research [7, 58, 66–68]. Here, we focus on the ones using directional antennas, which can be classified into two categories: none busy-tone based protocols [6, 38, 69–83] and busy-tone based

protocols [48, 49, 84–93]. The following subsections provide a brief review of the recent solutions in both categories.

### 2.3.1 None Busy-Tone Based Protocols

The Directional MAC (DMAC) proposed by Ko et al. [94] is one of the earliest protocols that support directional antennas. Based on a modified 802.11, DMAC uses a per-sector blocking mechanism to block any sector once it senses an RTS or CTS packet. Ko et al. have suggested two schemes: DMAC-1 and DMAC-2. The latter is used when none of the source node's antenna sectors is blocked to overcome the control packet collision problem found in DMAC-1. Therefore, a node can transmit its RTS packet in an omni-directional fashion according to DMAC-2 when none of its sectors is blocked; otherwise, it beams toward its destination as in DMAC-1. The omni-directional packet transmissions may cause unnecessary blocking, and the protocol requires a GPS system to identify neighbor's locations.

Nasipuri et al. [95] suggested that both the source and destination nodes exchange their RTS/CTS packets in an omni-directional fashion (ORTS/OCTS) using all available sectors. This helps both the source and the destination nodes to identify the direction of each other and it also helps to notify their neighbors about their intended communication. After a successful ORTS/OCTS handshake, the source and the destination nodes proceed with their communication using the antennas from which they received the OCTS/ORTS at its maximum power. The protocol is very simple and efficient in minimizing the hidden-terminal problem. However, it creates a severer exposed-terminal problem and it did not handle the deafness problem.

Choudhury et al. [70] proposed a MAC protocol called Multihop RTS MAC (MMAC) in which they suggested that all packets including RTS/CTS should use directional transmission (DRTS/DCTS). Nodes, however, may listen in an omni-

directional mode while they are idle. The deafness problem still exists as not all neighboring nodes can receive the DRTS and DCTS.

The Directional Virtual Carrier Sensing (DVCS) protocol was proposed by Takai et al. in [96]. The protocol assumes a steerable antenna system which can be pointed at any specified direction. Each node maintains a list of neighbors and their directions based on the address of arrival (AoA) of any sensed signal. The AoA information is used by the wireless nodes to beam their RTS packets directly to their destinations. However, if no location information exists, then the RTS packets are transmitted omni-directionally. A directional version of the Network Allocation Vector (DNAV) is maintained for channel reservation. Although the protocol handles some basic functions required to support the directional antennas, it does not provide any suggestion to handle the hidden-terminals and deafness problems.

The protocols in [97, 98] suggested a circular directional RTS in which an RTS packet has to be transmitted multiple times in each direction. This helps to identify the location of the source node by its intended destination which on the other hand replies by a CTS packet at the direction of the source node. Sending the RTS packet at all possible directions helps to notify all of the neighbors about the intended communication. However, this would not eliminate the deafness problem. The protocols also require synchronization mechanisms and cause undesired waste of time. In addition, the previous RTS/CTS based mechanisms cannot be used for multicasting and broadcasting [88].

### **2.3.2 Busy-Tone Based Protocols**

Using busy-tone to enhance the MAC protocol has been an active topic [48, 49, 84–93].

The tone-based directional MAC (ToneDMAC) protocol proposed by Choudhury and Vaidya in [84] uses two separated channels: a data channel and a control channel.

While the data channel is used to transmit the RTS/CTS/DATA/ACK packets, the control channel is used to transmit a busy-tone signal. A unique busy-tone is assigned to each wireless node so it can be identified and each node should maintain a hash function for all neighbors' locations. When a source node has data to transmit, it transmits a directional RTS packet toward its destination immediately after sensing the medium at the intended direction. The destination node in response replies with a directional CTS packet back to the source node. The source and destination nodes continue with exchanging the actual data at the specified directions and meanwhile they transmit a busy-tone omni-directionally. If the source node detects a busy-tone rather than receiving a CTS packet, it then concludes a deafness situation. The protocol can identify some deafness situations; however, there are chances to miss the busy-tone signal from either or both the source and destination nodes which do not guarantee a deafness-free protocol. Also, in order to avoid the hidden-terminal problem, the busy-tone signal needs to be transmitted simultaneously as the RTS packet and it also needs to be sensed before any other transmission.

Kulkarni and Rosenberg [86] proposed that the busy-tone signal to be transmitted by the destination node toward the direction of the source node only. The communication first starts with a DRTS/DCTS packets exchange in a directional manner. The redundant busy-tone signal would serve as another way to inform other nodes of the ongoing transmission in case they missed the DCTS packet. However, the deafness problem has not been addressed which degrades the performance of the protocol.

The Dual Busy Tone Multiple Access with Directional Antennas (DBTMA/DA) proposed by Huang et al. [87] is a modified version of the Dual Busy-Tone Multiple Access (DBTMA) in [99] to accommodate the nodes with directional antennas. As in the original DBTMA, the DBTMA/DA uses two distinctive busy-tones: a transmitter's busy-tone ( $BT_t$ ) and a receiver's busy-tone ( $BT_r$ ). The receiver turns-

on its  $BT_r$ , upon receiving the RTS packet while the transmitter turns-on its  $BT_t$  upon receiving the CTS packet. Therefore, hidden-terminals are notified after the CTS is being transmitted by the receiving node leading to a large gap during which several collisions may occur.

In summary, how to solve the deafness problem and minimize the hidden terminal and exposed terminal problems for MAC protocol design is still an open issue which motivates us to propose the DSDMAC protocol in Chapter 5.

## Chapter 3

# Analysis of Random Access Multihop Wireless Networks with Hidden Terminals

### 3.1 Introduction

Wireless multihop ad hoc networks allow limited-range wireless devices such as sensor nodes or other mobile devices to communicate with remote destinations without network infrastructure. Multihop relay allows the wireless nodes in the network to forward packets until they reach their final destinations, while conserving their power without compromising overall system throughput.

In order to understand the performance of the wireless multihop ad hoc networks and to optimize the design of their protocols, an accurate analytical model is required. The analysis for random access multihop networks is challenging due to the random contention among users and the existence of the hidden-terminals.

In the literature, the link throughput in wireless multihop ad hoc networks has been investigated mainly by simulations or by approximated models. In addition, the MAC layer delay has not yet been studied analytically. In this chapter, we propose an analytical model to quantify the MAC performance in both throughput and delay

in multihop ad hoc networks with the hidden terminal problem. The model considers a random distribution for the node locations within a network area. Our proposed analytical framework can be extended to analyze many wireless MAC protocols.

The main contributions of this chapter are threefold. We first model the link throughput of random access wireless multihop networks, by extending the analytical model in [7]. Second, we further quantify the MAC delay in multihop ad hoc networks. Finally, different from the simplified disk-model that are often used in the literature to study the hidden-terminal problem, we consider the interference caused by the hidden-terminals on the performance by considering the realistic signal-to-interference-plus-noise ratio (SINR).

When applied, these models have revealed important insight. The impact of adjusting the transmission range on the throughput and delay have been quantified. Thus, it is possible to adjust the transmission range to optimize the whole network performance, given the node density of the network. The accuracy of the proposed analytical models are verified by extensive simulations with NS-2. The analytical and simulation results provide important guidelines for network planing and protocol optimization in wireless multihop ad hoc networks.

This chapter is organized as follows. In Section 3.2, we first present the network setting followed by a brief introduction to the hidden-terminal problem, and then we discuss the effect of the mobility on MAC protocols. We then present the analytical models for determining the link throughput and delay in Section 3.3 and in Section 3.4, we use the realistic SINR model to determine the hidden-terminal problem. In Section 3.5, we validate our models by simulation and discuss our obtained results, followed by the chapter summary in Section 3.6.

## 3.2 Network Setting and Problem Definition

In the following subsections, we first present the network setting followed by a brief introduction to the hidden-terminal problem, and then we discuss the effect of the mobility on MAC protocols.

### 3.2.1 Network Setting

We assume that, the wireless nodes are randomly distributed according to a two-dimensional *Poisson* distribution in an area. All active nodes are assumed to be saturated, i.e., they always have packets available for transmission, and the packets are of the same length. We consider a general carrier sense multiple access with collision avoidance (CSMA/CA) MAC protocol; our approach is applicable to many other non-carrier sense protocols such as Aloha with minor changes. Each node employs a backoff algorithm before transmission. The time step value  $T$  is assumed to be equal to the propagation delay  $\delta$ . We also assume that all the wireless nodes are identical with a similar transmission range  $R$ , and collisions occur at the receiver when nearby nodes (less than  $R$  away) are transmitting simultaneously.

In the following subsection, we introduce the hidden-terminal problem.

### 3.2.2 Hidden-Terminal Problem

Multihop ad hoc networks are naturally vulnerable to the so called *hidden-terminal* problem. The problem was first pointed out by Tobagi and Kleinrock in [5]. This problem arises from nodes that are located within the sensing region of the intended destination and off-range of the source node.

One of the earliest solutions to minimize the interference of the hidden-terminals is by using the RTS/CTS mechanism. A pair of nodes can reserve wireless resources

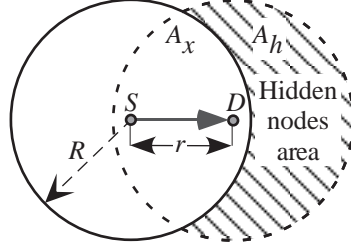

Figure 3.1: Illustration of hidden-terminal area.

by exchanging RTS and CTS messages, and other nodes that receive either the RTS or the CTS packet should defer their transmissions.

In order to estimate the impact of hidden-terminals, we need to define the region where possible hidden-terminals exist. As shown in Fig. 3.1, for transmission from the source node  $S$  to the destination node  $D$ , the shaded area illustrates the locations at which possible hidden-terminals reside. This area can be easily calculated using geometry as:

$$A_H(r) = \pi R^2 - 2R^2 \left[ \arccos\left(\frac{r}{2R}\right) - \frac{r}{2R} \sqrt{1 - \left(\frac{r}{2R}\right)^2} \right], \quad (3.1)$$

where  $r$  is the distance between nodes  $S$  and  $D$  which can take any value between  $0 \leq r \leq R$ . We assume that a sending node selects a destination from one of its neighbors at equal probability and therefore, the probability density function for locating the receiving node at a distance  $r$  is given by:

$$p_r(r) = \frac{2r}{R^2}, \quad \text{for } 0 \leq r \leq R. \quad (3.2)$$

Hence, the average value of the hidden-terminals' area  $A_h$  can be expressed as:

$$A_h = \int_0^R p_r(r) A_H(r) dr = \frac{2}{R^2} \int_0^R r A_H(r) dr. \quad (3.3)$$

By substituting (3.1) in (3.3), we obtain  $A_h = \frac{3\sqrt{3}}{4} R^2$ .

### 3.2.3 Effect of Mobility on MAC Protocols

Mobility in the wireless multihop ad hoc networks may affect both routing and MAC protocols. While the routing protocols need to deal with the change of the connectivity among the wireless nodes, MAC protocols can only be affected if the time scale of the MAC frame transmission is similar to the time scale of the changes in the network. However, from the following example the time to complete a MAC transaction is very short compared to the time scale of network connectivity changes due to mobility. Considering a vehicle traveling at a speed of 90 km/h in a highway, the time required to move the vehicle by 1 m is 40 ms while a 12,000-bit packet requires only 2.2 ms transmission time by an IEEE 802.11 link with a data rate of 11 Mbps. Accordingly, the mobility has a very limited impact on the MAC protocols and it has a greater impact on the routing protocols which are beyond the scope of this thesis.

## 3.3 Throughput and Delay Analyses

For an active node, we denote  $a$  the probability that the node transmits a packet (RTS) in a given time slot.  $p$  is the probability that the transmission is collided with other transmissions.  $a$  and  $p$  interact with each other: with a larger value of  $a$ , the collision probability  $p$  will be increased; with a larger value of  $p$ , more nodes will increase their backoff durations so the value of  $a$  will be reduced. In steady state, we can assume that  $a$  and  $p$  are constant for the tagged node. If the network is homogeneous, i.e., the number of neighboring nodes for each node is constant, we can assume  $a$  and  $p$  are the same for all nodes. To understand the network performance, the first issue is to obtain the value of  $a$  and  $p$  in steady state.

### 3.3.1 Packet Transmission Probability

Given a single-hop IEEE 802.11 WLAN, Bianchi has established a two-dimensional Markov model to derive the packet transmission probability for a saturated node (a node that always has a packet to transmit) at a randomly chosen slot of time as [7]:

$$a(p) = \frac{2}{1 + W + pW \frac{(2p)^m - 1}{2p - 1}}, \quad (3.4)$$

where  $W$  is the minimum backoff window size and  $m$  is the retry limit. The reader may refer to Bianchi's work for detailed derivation of this equation. We can use a similar approach to build a two-state Markov chain for a saturated node with other random-access MAC protocols and obtain the relationship between  $a$  and  $p$ . This step is straight-forward and we omit it due to the page limit. Next, we need to investigate how  $a$  affects the value of  $p$  in multihop networks.

### 3.3.2 Collision Probability

Let  $c_x$  be the event that a collision has occurred by one or more nodes within the area  $A_x$  in Fig. 3.1 and let  $c_h$  be the event that a collision has occurred by one or more nodes within  $A_h$  area. Therefore, the collision probability  $p$  is given by:

$$p = p_{cx} + p_{ch} - p_{cx}p_{ch}, \quad (3.5)$$

where  $p_{cx}$  is the probability of the event  $c_x$  and likewise  $p_{ch}$  is the probability of the event  $c_h$ . The probability  $p_{cx}$  is given by:

$$\begin{aligned} p_{cx} &= Pr \{ \text{two or more active nodes within } A_x \} \\ &= \sum_{j=2}^{\infty} \left( \frac{\sum_{i=j}^{\infty} \binom{i}{j} a^j (1-a)^{i-j} (\lambda A_x)^i e^{-\lambda A_x}}{i!} \right) \\ &= 1 - (1 + a\lambda A_x) e^{-a\lambda A_x}, \end{aligned} \quad (3.6)$$

where  $\lambda$  is the node density and

$$A_x = \pi R^2 - A_h. \quad (3.7)$$

Similarly,  $p_{ch}$  can be obtained as:

$$\begin{aligned} p_{ch} &= Pr \{ \text{only one active node within } A_x \} \\ &\quad \cdot Pr \{ \text{one or more active nodes within } A_h \} \\ &= a\lambda A_x (1 - e^{-(1-a)\lambda A_x}) \\ &\quad \cdot (1 - e^{-\lambda A_h(1-(1-a)^v)}) e^{-a\lambda A_x}. \end{aligned} \quad (3.8)$$

where  $v$  is the vulnerable period during which a collision caused by hidden-terminals may occur. At this point,  $a$  and  $p$  can be computed using numerical methods.

### 3.3.3 Throughput Analysis

We start our throughput analysis by defining the average duration of a successful packet transmission and the average duration of the time due to collisions. As an example, consider the IEEE 802.11 DCF protocol with the RTS/CTS mechanism enabled. Fig. 3.2 illustrates: (a) a successful packet transmission duration; (b) a collided packet transmission duration during an RTS period; and (c) a collided packet transmission duration during a CTS period. Here in the figure,  $RTS$ ,  $CTS$  and  $ACK$  are the durations of RTS, CTS and ACK packets respectively. The time  $SIFS$  is the Short Interframe Space, and the time  $DIFS$  is the Distributed Interframe Space. Let  $T_s$  be the average time the channel is sensed as busy because of a successful transmission;  $T_{cx}$  is the wasted time when a collision occurs during an RTS transmission; and  $T_{ch}$  is the wasted time when a collision is caused by a hidden-terminal. Therefore,

$$\begin{aligned} E[T_s] &= RTS + SIFS + \delta + CTS + SIFS + \delta + H \\ &\quad + E[P] + SIFS + \delta + ACK + DIFS + \delta, \end{aligned} \quad (3.9)$$

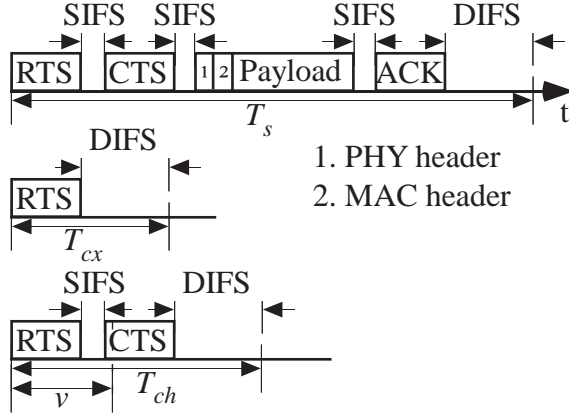

Figure 3.2: Packet transmission: (a) a successful packet transmission, (b) a collision during RTS period, (c) a collision during CTS caused by hidden-terminals.

where  $\delta$  is the propagation delay. The time  $H$  and the time  $P$  are the durations of the packet header (PHY and MAC headers) and the packet payload respectively.

$$T_{cx} = RTS + DIFS + \delta, \quad (3.10)$$

$$T_{ch} = RTS + SIFS + \delta + CTS + DIFS + \delta. \quad (3.11)$$

For simplicity, the  $T_{ch}$  value is assumed for the worst case scenario when a hidden node collides with the CTS packet. The vulnerable period  $v$  for the previous example is given by:

$$v = RTS + SIFS + \delta + T. \quad (3.12)$$

For the sake of completeness, we also consider the situation when the RTS/CTS mechanism is not used (such as the basic transmission mode of an IEEE 802.11 wireless device). In this case, as shown in Fig. 3.3, we have

$$E[T_s] = H + E[P] + SIFS + 2\delta + ACK + DIFS, \quad (3.13)$$

$$E[T_{cx}] = H + E[P] + DIFS + \delta, \quad (3.14)$$

$$E[T_{ch}] = H + E[P] + DIFS + \delta. \quad (3.15)$$

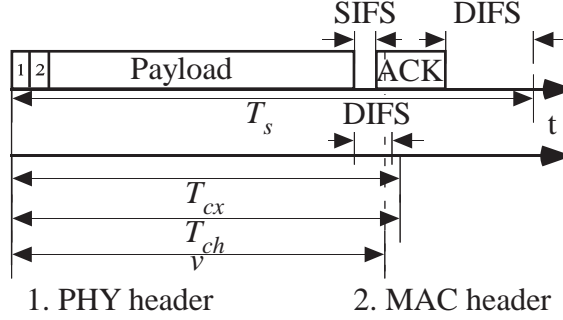

Figure 3.3: Packet transmission, collision and vulnerable period durations:  $T_s$ ,  $T_{cx}$ ,  $T_{ch}$  and  $v$  when RTS/CTS is not used.

Similarly, the vulnerable period  $v$  can also be expressed as:

$$v = H + E[P] + SIFS + \delta + T. \quad (3.16)$$

Let  $Th$  be the per-node per-hop link throughput which can be expressed as the percentage of time a tagged node is transmitting successfully; then,

$$Th = \frac{t_s}{t_i + t_o + t_c + t_s}, \quad (3.17)$$

where  $t_s$  is the time spent by a tagged node in a successful transmission which is given by:

$$t_s = ap_n(1 - p) \cdot E[T_s]. \quad (3.18)$$

Here,  $p_n$  is the probability of finding two or more nodes within the range of our tagged node and can be obtained as:

$$p_n = 1 - (1 + \lambda\pi R^2)e^{-\lambda\pi R^2}, \quad (3.19)$$

$t_i$  is the time when the wireless channel around the tagged node is sensed idle which is given by:

$$t_i = P_{idle}(1 - a) + (1 - p_n) - P_{idle}(1 - a)(1 - p_n). \quad (3.20)$$

Here  $P_{idle}$  is the probability that the tagged node senses the channel as idle and it can be obtained as:

$$\begin{aligned}
P_{idle} &= \frac{1}{p_n} \left[ \sum_{i=2}^{\infty} (1-a)^i \frac{(\lambda\pi R^2)^i}{i!} e^{-\lambda\pi R^2} \right. \\
&\quad \left. + \sum_{i=2}^{\infty} a(1-a)^{i-1} \frac{(\lambda\pi R^2)^i}{i!} e^{-\lambda\pi R^2} \right] \\
&= \frac{e^{-a\lambda\pi R^2} - (1 + \lambda\pi R^2 - a\lambda\pi R^2)e^{-\lambda\pi R^2}}{(1-a) \cdot p_n}, \tag{3.21}
\end{aligned}$$

$t_o$  is the time when the channel is used by the other nodes:

$$\begin{aligned}
t_o &= p_n \left( (1 - P_{idle})(1-a)(1-p) \cdot E[T_s] \right. \\
&\quad \left. + (1 - P_{idle})(1-a)(p_{cx} \cdot E[T_{cx}] \right. \\
&\quad \left. + p_{ch} \cdot E[T_{ch}] - p_{cx}p_{ch} \cdot E[T_{ch}]) \right), \tag{3.22}
\end{aligned}$$

and  $t_c$  is the time during which our tagged node experiences collisions:

$$t_c = ap_n (p_{cx} \cdot E[T_{cx}] + p_{ch} \cdot E[T_{ch}] - p_{cx}p_{ch} \cdot E[T_{ch}]). \tag{3.23}$$

Finally, we can use (4.11) to derive the per-hop throughput ( $Th_{per-hop}$ ) as:

$$Th_{per-hop} = Th \times \frac{E[P]}{E[T_s]}. \tag{3.24}$$

### 3.3.4 Delay Analysis

For delay analysis, we first need to define the probability at which a node will successfully transmit a packet after  $n$  unsuccessful attempts. This probability is given by:

$$p_s(n) = p^n(1-p). \tag{3.25}$$

The average number of these unsuccessful attempts is given by:

$$n_a = \sum_{n=0}^m np_s(n), \tag{3.26}$$

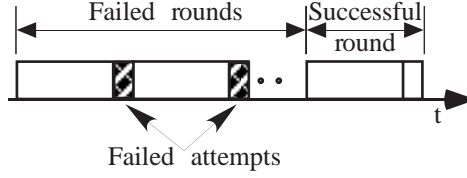

Figure 3.4: Transmission attempts rounds.

where  $m$  is the retransmission limit. For the tagged node, the time between two successful transmissions are divided into failed rounds and a successful round, as shown in Fig. 3.4. For each failed round, the channel around the tagged node spends its time in the idle state, in other nodes' successful transmissions, in other nodes' collisions, and in a failed attempt by the tagged node. Therefore, the expected duration of a failed round can be expressed as:

$$E[\text{failed round duration}] = \frac{t_i + t_o + t_c}{a(1 - a(1 - p))}. \quad (3.27)$$

Here, the numerator represents the average time the channel is involved in unsuccessful transmission, and the denominator represents the probability of unsuccessful round. Similarly, the channel in a successful round spends its time in its idle states, in other nodes' successful transmissions, in other nodes' collisions, and finally in a successful attempt by the tagged node. Therefore, the expected duration of the successful round is given by:

$$E[\text{successful round duration}] = \frac{t_i + t_o + t_s}{a(1 - ap)}, \quad (3.28)$$

where the numerator is the average time the channel is not involved in a collision caused by the tagged node, and the denominator is the probability that the channel is not collided by the tagged node. The tagged node repeats on average  $n_a$  rounds before it successfully delivers its packet. The average waiting time for a packet before a successful transmission is given by:

$$W = n_a \times E[\text{failed round duration}]. \quad (3.29)$$

Finally, the average delay a packet can experience before a successful delivery can be expressed as:

$$delay = W + E[\text{successful round duration}]. \quad (3.30)$$

### 3.4 Interference from Hidden-Terminals

In the previous section, similar to many previous work, we assumed that a single transmission from any of the hidden-terminals during the source node transmission to the destination node will cause a collision. This assumption is not accurate when considering the signal attenuation and the signal to interference and noise ratio. In this section, we consider the realistic signal-to-interference-plus-noise ratio (SINR) in our analytical model. Assuming that all the wireless nodes are identical with the same transmission power, the SINR is given by [100]:

$$SINR = \frac{G}{\frac{N_0 B}{P_r} + \sum_{i \neq S} \frac{r^\alpha}{d_i^\alpha}}, \quad (3.31)$$

where  $G$  is the spread spectrum modulation gain,  $d_i$  is the distance between the source node and the interfering (hidden-terminal) node,  $\alpha$  is the path-loss exponent which is a constant taking the value between 2 to 6 depending on the propagation environment, and  $N_0$  is the additive white Gaussian noise spectral density [101].  $N_0 = kT(F - 1)$  where  $k$  is the Boltzmann's constant,  $T$  is the absolute device temperature in Kelvins (290K for 17°C),  $F$  is the device noise figure (5 – 10 dB for 802.11) [102], and  $B$  is the information signal bandwidth and  $P_r$  is the received signal power.

In order to study the interference caused by the hidden-terminals, we plotted (3.31) for multiple interfering nodes which assumed to be at the shortest possible distance from our destination node ( $d_i = R - r$ ). The upper curve in Fig. 3.5 is for a single interfering node while two, three and more interfering nodes are indicated by

the successive curves below. The solid line at 40dBm represents the required SINR threshold value for QPSK modulation. It can be noticed that for  $0 \leq r \leq 0.5R$ , the received signal is above the threshold value despite the hidden-terminals interference, so the received packet can still be decoded successfully with high probability, which is called “capture-effect”.

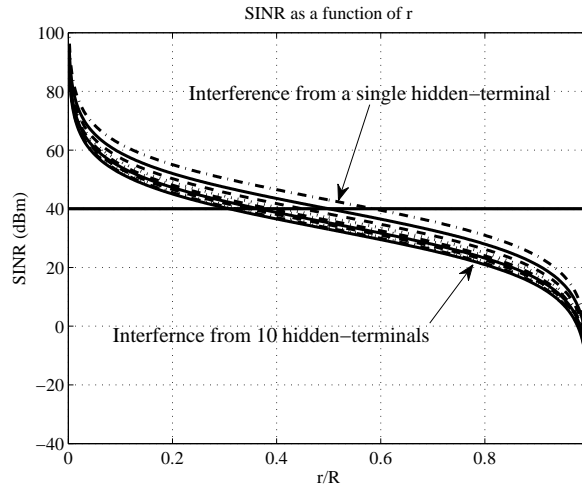

Figure 3.5: The SINR as a function of source-destination distance  $r$  for a multiple of interfering nodes.

In order to reflect this result in our analytical model in Section 3.2.2, we assume a circle drawn around the source node centered at the origin with a radius  $R$ , where  $R$  is the source node transmission range as shown in Fig. 3.6. Also consider a circle drawn around the destination node centered at  $(r, 0)$  with a radius of  $d$ , where  $d$  is the longest distance at which only one single interfering node can cause a collision at our destination node. Accordingly, the two circles drawn around the source and destination nodes may only intersect with each other when  $R/2 \leq d \leq R$  creating a

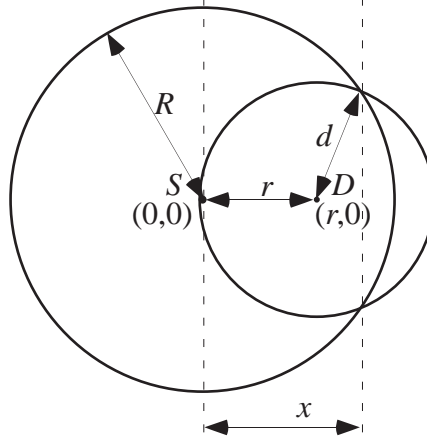

Figure 3.6: Calculating hidden area for the case when the SINR is considered.

chord at  $x$  from the origin which is given by:

$$x = \frac{r^2 - x^2 + R^2}{2r}. \quad (3.32)$$

Therefore, the hidden-terminal area  $A_H(r)$  in (3.3) can be recalculated using  $x$  as:

$$A_H(r) = \begin{cases} x^2 \arcsin\left(\frac{a}{2x}\right) - R^2 \arcsin\left(\frac{a}{2R}\right) + \frac{ar}{2}, & \text{for } x \geq r \\ \pi x^2 - x^2 \arcsin\left(\frac{a}{2x}\right) - R^2 \arcsin\left(\frac{a}{2R}\right) + \frac{ar}{2}, & \text{otherwise} \end{cases} \quad (3.33)$$

Also, the area  $A_x$  in (3.7) is estimated as

$$A_x = \frac{2}{R^2} \int_0^R x A_H(x) dx. \quad (3.34)$$

The new values of  $A_H(r)$  and  $A_x$  can be applied into our previous analytical models to refine the analysis. In the following section, we will present and discuss the obtained results.

### 3.5 Model Validation and Performance Evaluation

In order to validate the link throughput and delay models, we compared the analytical results with NS-2 simulation results. The simulations are based on the “CMU’s Monarch group’s Wireless and Mobility extension project to NS2,” which provides an implementation to the IEEE 802.11 DCF mode with ad hoc routing protocols.

The values of the system parameters used in our simulations and in our analysis are summarized in Table (3.1 and 3.2), respectively. These parameters are set to comply with the IEEE 802.11 DCF specifications. The wireless nodes are distributed randomly using a two-dimensional *Poisson* distributions within an area of  $900 \times 900 \text{ m}^2$ . All nodes are equivalent and use omni-directional antennae in free space (no obstacles). In order to avoid the edge effect, only the transmissions among nodes that are located in the center of the network are considered. Fig. 3.7 captures a random snapshot of nodes distribution from a randomly chosen simulation run. To maintain the required density in the center (where the results are collected), the network is divided into nine sectors; in each sector, nodes are distributed randomly according to the *Poisson* distribution. Nodes are loaded with CBR traffic with rates high enough to achieve traffic saturation.

#### 3.5.1 Throughput Results

Fig. 3.8 shows the expected throughput that can be achieved at any given hop in the network (per-hop throughput). The solid curve in the figure represents the results which reflects the SINR assumptions while the dashed curve represents the original analysis. In the simulation, we also use the similar two models to trigger the collision event, i.e., for the SINR model, a packet is corrupted if the received SINR is below the SINR threshold (thanks to the capture effect); for the original model, a packet is corrupted if the interference power is above the

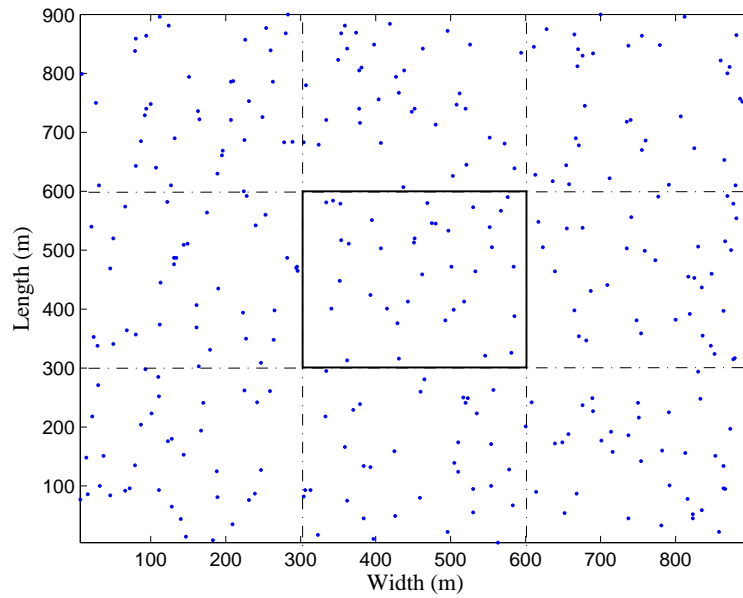

Figure 3.7: A random snapshot of node distribution in simulations. The area represented by the square in the middle includes nodes under test.

Table 3.1: Physical parameters.

Parameter	Value
PHY	DSSS
$CW_{min}$	31
$CW_{max}$	1023
$m$	7
Channel data rate	11 Mbps
Basic data rate	1 Mbps
Propagation delay ( $\delta$ )	1 $\mu$ s
Slot Time ( $\sigma$ )	20 $\mu$ s
SIFS	10 $\mu$ s
DIFS	50 $\mu$ s

Table 3.2: Packet parameters.

Parameter	Value
packet payload	12000 bits
MAC header	272 bits
PHY header	192 bits
ACK	304 bits
RTS	352 bits
CTS	304 bits

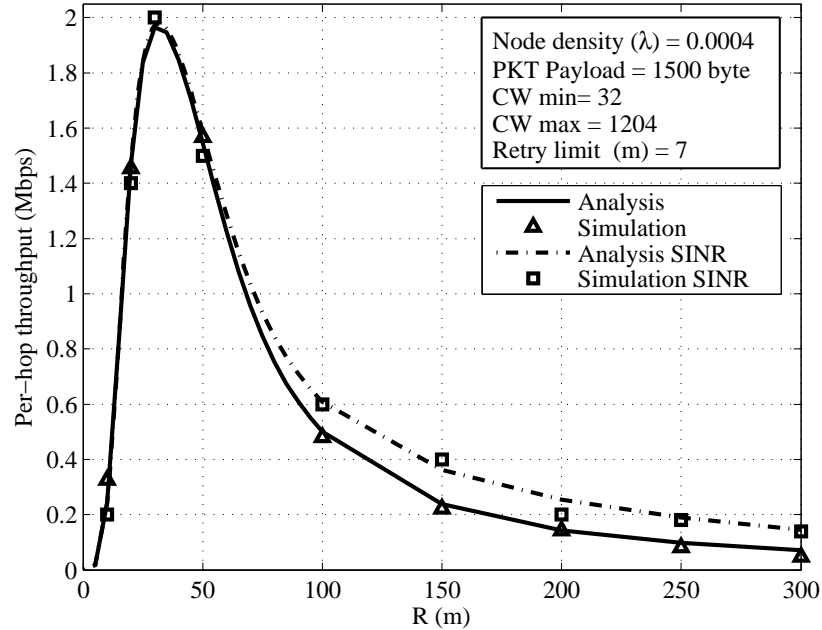

Figure 3.8: Per-hop throughput: analysis versus simulation.

threshold (the capture effect is ignored). The node density is set to  $0.0004 \text{ node/m}^2$  ( $(9 \times 36 \text{ nodes}) / (300 \times 300 \times 9 \text{ m}^2)$ ).  $R$  was varied from 0 to 300 m (the width of the network under test). From the figure, first, the accuracy of the analysis is validated by the simulation results. Second, we notice that, with a very small transmission range, where the probability of finding neighbors is very low, the throughput is also very low; then, enlarging the transmission range can quickly increase the throughput. After it reaches its peak, the throughput starts to decline as the transmission range increases. This is because, with an even larger transmission range, although the probability of finding neighboring nodes increases with the transmission range, there are more contending nodes and hidden terminals which result in a higher collision rate and lower throughput. Third, the gap between the dashed curve and the solid curve shows that without considering the capture effect, the original model under-estimate

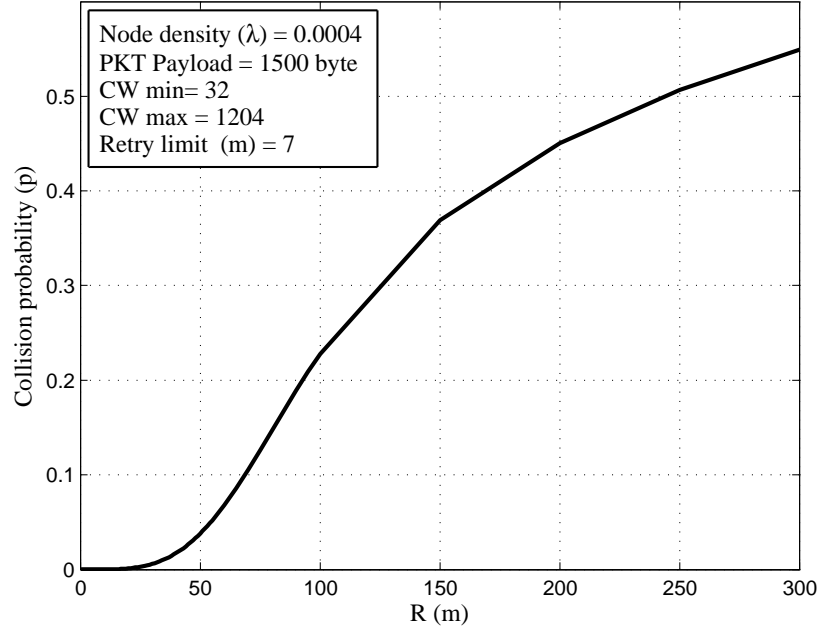

Figure 3.9: The Collision probability  $p$  versus  $R$ .

the network throughput, especially when the transmission range is large.

Fig. 3.9 shows the collision probability  $p$  versus  $R$ . The shape and the peak position of the throughput curve depends on the node density  $\lambda$  as shown in Fig. 3.10. The results are those using the SINR model. From Fig. 3.10, we also notice that the maximum achieved throughput (for saturated nodes) is related to both the transmission range and the node density. In other words, given the node density, it is possible to adjust the transmission range to maintain the link throughput.

### 3.5.2 Delay Results

The delay shown in Fig. 3.11 represents the MAC delay that a packet experiences from the time it is ready for transmission till it is successfully received by the receiver.

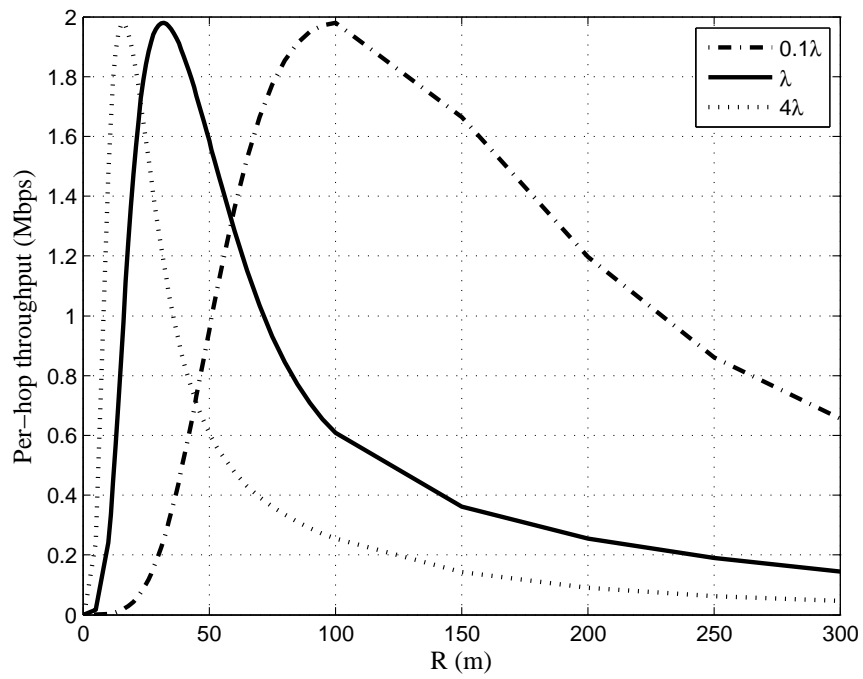

Figure 3.10: Per-hop throughput versus transmission range ( $R$ ) for different values of node densities ( $\lambda$ ).

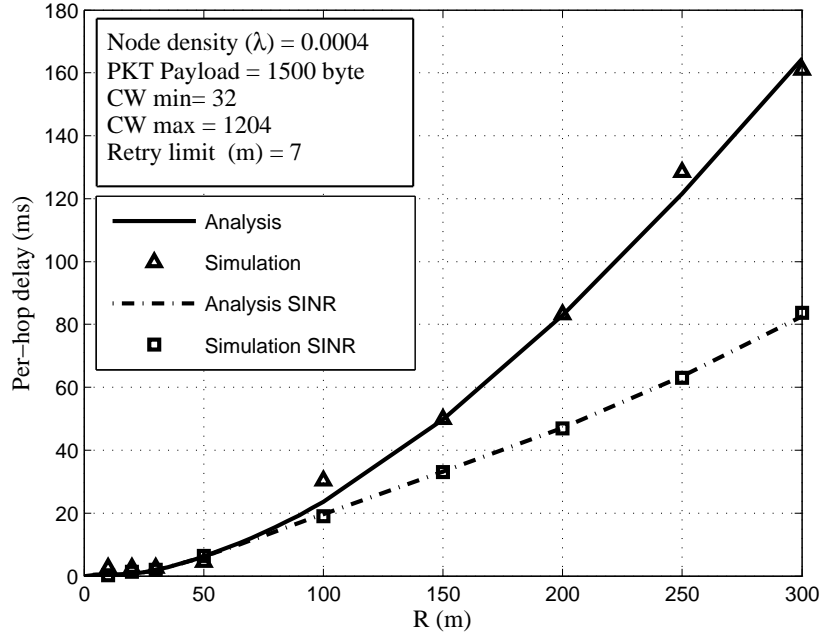

Figure 3.11: Per-hop delay: analysis versus simulation.

Note that we ignore the packets failed to be delivered in calculating the delay. The solid curve in the figure represents the results which reflect the SINR model while the dashed curve represents the original analysis. Both results were validated by simulation results. According to the figure, we see that as the transmission range increases, the delay also increases, as more retransmissions due to collisions prolong the delay. The node density also has a great influence on the delay. As shown in Fig. 3.12, the delay increases when the node is denser and more collisions happen. If we need to bound the MAC delay for a given density network, we can adjust the transmission range (e.g., by adjusting the transmission power) accordingly. Overall, the figures in this section also show that the analytical results match well with the simulation ones, which demonstrates the accuracy of our analysis. From the results, we can adjust the transmission range and sensing range to optimize the whole network

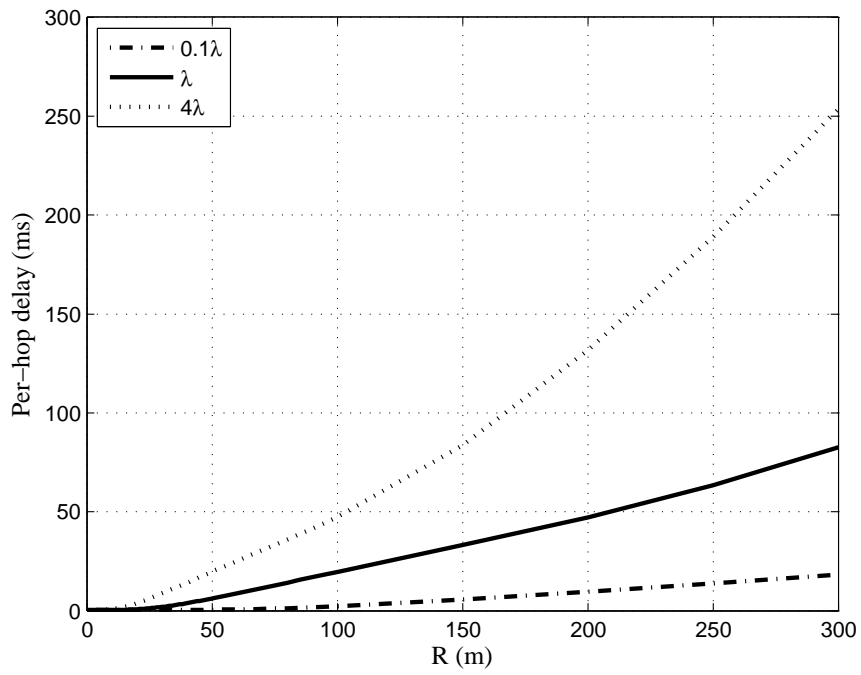

Figure 3.12: Per-hop delay versus transmission range ( $R$ ) for different values of node densities ( $\lambda$ ).

performance in terms of maximizing link throughput with bounded MAC delay, given the node density of the network.

### **3.6 Chapter Summary**

In this chapter, we have presented simple yet accurate analytical models to compute the saturation throughput and delay in wireless multihop ad hoc networks. The models have also been extended to investigate the realistic hidden-terminal effect by considering the signal to interference ratio. The proposed analytical models can be applied to many wireless MAC protocols and applications. Using our proposed models, we have examined the performance of the wireless multihop ad hoc networks under various transmission ranges. The results have shown the quantitative relationships between the link throughput and delay performance in the wireless multihop networks and the transmission range, given the node density. The results obtained by our models have been validated using NS-2 simulations which show that our models are accurate in predicting both throughput and delay.

## Chapter 4

# Enhanced Busy-Tone-Assisted MAC Protocol for Wireless Ad Hoc Networks

Wireless multihop ad hoc networks rely on a series of relay nodes (which can be any node within the network) to forward data packets to reach further destinations. However, when the network density is getting larger, the data packets will become prone to more collisions. Even with carrier sensing techniques, hidden-terminals which naturally exist in such networks can still lead to severe collisions. The hidden terminals normally reside within the receiver's interference range but away from the sender's sensing range.

How to overcome the hidden-terminal problem has been a very active research topic. However, most of the existing solutions can cause a very large area of blocked wireless nodes. For example, with the Busy-Tone Multiple Access (BTMA) protocol proposed by Tobagi and Kleinrock [5], nodes collaboratively transmit busy-tone signals to a region covering twice of the data transmission range in order to reach all hidden-terminals. The scheme was successful in reducing collisions due to hidden-terminals; however, it increases the number of unnecessarily blocked nodes. This is called the exposed-terminal problem. Although there are other

variations that managed to reduce the blocking areas, they were not able to effectively mitigate the hidden-terminal problem or in some cases failed to handle packet broadcasting/multicasting. Different from the previous solutions, where the busy-tone signal remains active for the whole duration of transmitting a data packet, our proposed protocol will let the busy-tone signal active for a very short period of time (only during the transmission of the RTS packet). This will help in solving the hidden-terminal problem without unnecessarily blocking a large number of wireless nodes for a lengthy duration.

The main contributions of this chapter are twofold. First we propose the enhanced busy-tone assisted MAC protocol that deals with both the hidden-terminal and the exposed-terminal problems. It can also ensure high reliability for packet broadcasting and multicasting. In a nutshell, during the transmission of the RTS packet, a non-interfering, out-of-band busy-tone signal is transmitted by the source node only. The busy-tone signal is transmitted at twice the data signal transmission range, so it can reach all of the hidden terminals. In such a way, the hidden-terminals will be notified promptly and hence we can minimize the collisions caused by hidden terminals. Consequently, the throughput and the delay of the wireless networks can be improved. Second, we study the protocol performance analytically and through simulation.

The remainder of this chapter is organized as follows. In Section 4.1, we introduce the hidden-terminal and exposed-terminal problems in ad hoc networks, and the concept of busy-tone. The enhanced busy-tone assisted MAC protocol is proposed in Section 4.2, and its performance is analyzed in Section 4.3. Simulation results are presented in Section 4.4, followed by the concluding remarks in Section 4.5.

## 4.1 Problem Definition

In the following subsections, we introduce the hidden-terminal and exposed-terminal problems in ad hoc networks. Also, we introduce the concept of busy-tone followed by discussing the problems with broadcasting/multicasting data packets to multiple destinations.

### 4.1.1 The Hidden-Terminal Problem

When wireless nodes are spread out in a large area, there will be a chance that some *hidden-terminals* to exist. The hidden-terminals may cause collisions at any time during data transmissions because they cannot sense the ongoing transmissions. The hidden-terminal problem was first mentioned by Tobagi and Kleinrock in [5]. As shown in Fig. 4.1, the shaded area  $A_h$  indicates the possible locations of hidden-terminals. The size of this area is given by:

$$A_H(r) = \pi R_t^2 - 2R_t^2 \left[ \arccos \left( \frac{r}{2R_t} \right) - \frac{r}{2R_t} \sqrt{1 - \left( \frac{r}{2R_t} \right)^2} \right], \quad (4.1)$$

where  $r$  is the distance between the source node  $S$  and the destination node  $D$ , and  $R_t$  is the transmission range.

For instance, considering the IEEE 802.11 protocol, the vulnerable period of collisions due to hidden-terminals is:

$$(4.2)$$

$$v = H + E[P] + SIFS + \delta + T, \quad (4.3)$$

where  $H$  is the packet header transmission time,  $P$  is the packet payload transmission time, SIFS is the short interframe space,  $\delta$  is the propagation delay and  $T$  is the

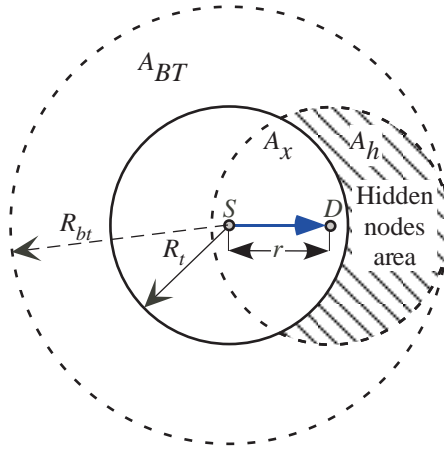

Figure 4.1: Busy-tone and hidden-terminals areas.

duration of an idle slot. When the RTS/CTS mechanism is used, this vulnerable period is reduced to:

$$v = RTS + SIFS + \delta + T, \quad (4.4)$$

where  $RTS$  is the transmission duration of the RTS packet.

#### 4.1.2 The Exposed-Terminal Problem

Unlike the hidden-terminals, the exposed-terminals are those nodes that are blocked from transmissions when a tagged node transmits, even though their transmissions do not collide with the tagged node. It is desirable to reduce the number of exposed-terminals in order to improve the aggregated throughput of the network. Theoretically, all nodes that are within the source node's transmission range but are not within the destination node's receiving range are exposed-terminals. However, when the sender needs to receive CTSs or ACKs, it becomes a necessity to block all nodes within the sender's transmission range.

### 4.1.3 The Busy-Tone

The busy-tone is a sine-wave signal transmitted at a well-separated frequency. It is used to notify the wireless nodes of the occupancy of the wireless channel. In order to cover all of the hidden-terminals, it is required to transmit the busy-tone signal at twice the transmission range ( $2 \times R_t$ ). As shown in Fig. 4.1, the outer dashed circular area  $A_{BT}$  is the area needed to be covered by the busy-tone signal. The area also indicate the nodes that will be blocked by the busy-tone signal from a simultaneous transmission.

The energy consumed by transmitting the busy-tone signal increases with regard to its transmission range as [103]:

$$E_t(R_{bt}) = k_1 R_{bt}^\omega + k_2, \quad (4.5)$$

where  $R_{bt}$  is the busy-tone transmission range,  $\omega$  is the path loss exponent,  $k_1$  is determined by the characteristics of the transmitter and the channel, and  $k_2$  is the transceiver energy consumption. Although the energy saving is out of the scope of this paper, it is possible to make the receiver more sensitive to the busy-tone signal (which does not contain high rate information bits) to enlarge its transmission range [49]. Alternatively, the busy-tone signal can be transmitted as ON/OFF pulses.

### 4.1.4 Packet Broadcasting/Multicasting Problem

In packet broadcasting/multicasting, there are multiple destinations to receive the packet. Thus, we cannot rely on the RTS/CTS mechanism to notify the hidden-terminals anymore, as multiple CTS messages may collide with each other. Also, in general, the number of hidden-terminals increases with respect to the number of receivers. Thus, it is desirable to block all the wireless nodes that are  $2 \times R_t$  away from the source node to ensure the reliability of broadcast and multicast messages.

## 4.2 Enhanced Busy Tone Multiple Access MAC protocol

The enhanced busy-tone multiple access (EBTMA) MAC protocol uses two well-separated wireless channels: a data channel and a busy-tone channel. The data channel is used to transmit data packets as well as RTS, CTS and ACK packets. The busy-tone channel is used to transmit a sine-wave busy-tone signal at twice the data signal transmission range.

When the link layer of a wireless node receives data packets from its higher layer (we call this node as a source node), it senses the activity on both channels. If both channels are idle, it can transmit the RTS immediately. Otherwise, it waits until it detects an idle period on both channels equal to a distributed interframe space (DIFS); then, it generates a random backoff interval before it starts to transmit. The backoff interval is chosen randomly from zero to the initial contention window (CW) size minus one. The backoff counter is decremented every idle slot duration and is frozen whenever the node senses an activity at any of the channels. The counter resumes decrementing after both channels become idle again for a DIFS time. Once the backoff counter reaches zero, the node turns-on its busy-tone signal and starts transmitting its RTS packet. The busy-tone signal should remain active for the whole duration of the RTS packet as shown in Fig. 4.2.

On the destination side, the receiving node (to which the RTS packet was addressed) replies with a CTS packet and waits for the data packet. Once the data packet is received successfully, the destination node acknowledges by sending an ACK packet back to the source node.

If the source node does not receive a CTS packet within a specified RTS-Timeout interval or it detects a transmission of a different packet, it reschedules the transmission of the packet for a later time and then it doubles its backoff CW. Similarly, if the source node does not receive an ACK packet within a specified ACK-

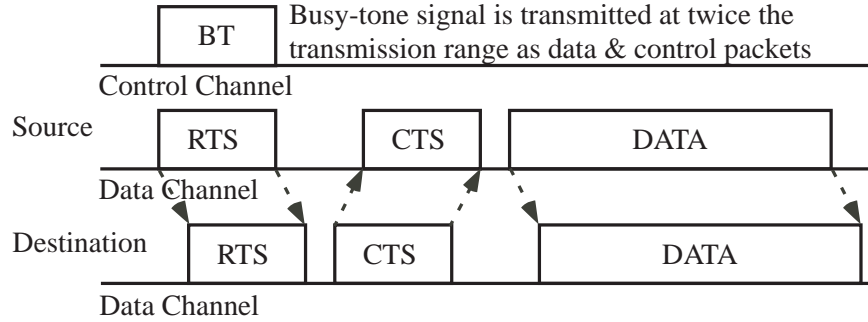

Figure 4.2: Packet transmission using EBTMA protocol.

Timeout interval or it detects a transmission of a different packet, it reschedules the transmission of the data packet for a later time and then it doubles its backoff CW.

Nodes that can only sense the busy-tone signal should remain idle and freeze their backoff counters (if they are in a backoff state) for the period of the busy-tone time plus a DIFS time. While other nodes that can hear both the RTS and the busy-tone signal should remain idle and freeze their backoff counters for the whole period of data packet transmission. This can be achieved using the network allocation vector (NAV) mechanism. Similarly, nodes that can hear the CTS should remain idle and freeze their backoff counters for the whole period of the data packet transmission.

Since the busy-tone has twice the transmission range, all nodes (including the hidden-terminals) will be notified within a single time step without interfering with any other ongoing transmissions. Also, because the busy-tone signal lasts for only a short period of time (during RTS transmission), only nodes within the range of the source node and within the range of the destination node will be blocked during the data transmission.

Another important feature of the proposed EBTMA protocol is that it can co-exist with the existing 802.11 MAC protocol, so it can be incrementally deployed.

### 4.2.1 Broadcast and Multicast

In packet broadcasting/multicasting, there are multiple destinations to receive the packet. Thus, we cannot rely on the RTS/CTS mechanism to notify the hidden-terminals anymore, as multiple CTS messages may collide with each other. Also, in general, the number of hidden-terminals increases w.r.t. the number of receivers. Thus, it is desirable to block all the wireless nodes that are  $2 \times R_t$  away from the source node to ensure the reliability of broadcast and multicast messages. The proposed protocol can handle the packet broadcasting/multicasting by simply letting the busy-tone signal remain active for the whole duration of the packet broadcasting/multicasting period.

## 4.3 Performance Analysis

Our analysis is an extension on the work in [104] which provided a general framework for wireless multihop ad hoc networks analysis. In this section, we make the following assumptions. The busy-tone signal has twice of the transmission range as the data and control message transmission range ( $R_{bt} = 2R_t$ ). For unicast transmissions, the RTS/CTS mechanism is used with busy-tone signal accompany the RTS packet transmission. Saturated wireless nodes (always have packets available for transmission) are distributed according to a *Poisson* distribution in a two-dimensional space. A carrier sensing scheme is used to sense the activity on both data and busy-tone channels. Each node deploys a random backoff algorithm, and the duration of an idle slot is  $T$ .

### 4.3.1 Collision Probability

According to [104], there are two possible regions of collision sources,  $A_x$  and  $A_h$  as shown in Fig. 4.1. Since the hidden-terminals within  $A_h$  region will be notified using the busy-tone signal during the  $RTS$  period, the vulnerable period at which hidden-terminals can cause a collision is equal to one ( $v = 1$  time step).  $p_{cx}$  is the probability that a collision has occurred by one or more nodes within  $A_x$  area which is given by:

$$p_{cx} = 1 - (1 + a\lambda A_x)e^{-a\lambda A_x}, \quad (4.6)$$

where  $a$  is the packet transmission probability,  $\lambda$  is the node density and  $A_x = \pi R^2 - A_h$ . The  $A_h$  is the average size of the hidden area which is:

$$A_h = \frac{2}{R_t^2} \int_0^R r A_H(r) dr. \quad (4.7)$$

The other collision component  $p_{ch}$  which represents the probability that a collision has occurred by one or more nodes within  $A_h$  area is given by:

$$p_{ch} = a\lambda A_x (1 - e^{-(1-a)\lambda A_x}) \cdot (1 - e^{-\lambda A_h(1-(1-a)^v)}) e^{-a\lambda A_x}. \quad (4.8)$$

### 4.3.2 Throughput Analysis

Here, we modify the model in [104] in order to consider our EBTMA MAC. We first define the various time quantities used in our analysis. The times  $RTS$ ,  $CTS$  and  $ACK$  are the transmission duration of RTS, CTS and ACK packets respectively. The time  $SIFS$  is the Short Interframe Space and the time  $DIFS$  is the Distributed Interframe Space. The time required to successfully transmit a data packet is

$$E[T_s] = RTS + SIFS + \delta + CTS + SIFS + \delta + H + E[P] + SIFS + \delta + ACK + DIFS + \delta, \quad (4.9)$$

where  $H$  and  $P$  are the transmission durations of the packet header (PHY and MAC headers) and the packet payload, respectively.  $\delta$  is the propagation delay. Since both types of collisions (which are mentioned earlier) can only occur at the first time step of transmitting the RTS packet, then the wasted time during any of these collisions is

$$T_c = RTS + DIFS + \delta. \quad (4.10)$$

Define a round as the time duration between the finishing times of two consecutive successful transmissions of the tagged node. We can define the per-hop throughput of a tagged node as:

$$Th = \frac{P_s E[T_s]}{E[slot]} \times R, \quad (4.11)$$

where,

$$E[slot] = P_s E[T_s] + P_i + P_c E[T_c] + P_{os} E[T_s] + P_{oc} E[T_c] + P_{bt} E[T_s] \quad (4.12)$$

and  $R$  is the channel data rate.  $P_s$  is the probability that a slot is occupied by the tagged node for a successful transmission and given by:

$$P_s = ap_n(1-p)(1-BT), \quad (4.13)$$

where,

$$p_n = 1 - (1 + \lambda\pi R^2)e^{-\lambda\pi R^2} \quad (4.14)$$

is the probability of finding two or more nodes within a single hop, and the collision probability  $p$  equals  $p_{cx} + p_{ch}$ , and  $BT$  is the probability that one or more nodes within  $A_{BT}$  area start transmission which is given by:

$$BT = 1 - \sum_{i=0}^{\infty} (1-a)^i \frac{(3\lambda\pi R^2)^i}{i!} e^{-3\lambda\pi R^2}. \quad (4.15)$$

$P_i$  is the probability that a slot is idle which is given by:

$$P_i = P_{idle}(1 - a)(1 - BT), \quad (4.16)$$

where  $P_{idle}$  is the probability that either all other nodes within the tagged node's sensing region are idle, or there are no nodes found within the sensing region of the tagged node.

$$P_{idle} = \left[ \sum_{i=2}^{\infty} (1 - a)^{i-1} \frac{(\lambda\pi R^2)^i}{i!} e^{-\lambda\pi R^2} \right] + (1 - p_n), \quad (4.17)$$

$P_{os}$  and  $P_{oc}$  are the probabilities that a slot is occupied by other nodes for successful transmissions and for collisions, respectively

$$P_{os} = (1 - BT)(1 - P_{idle})(1 - a)(1 - p) \quad (4.18)$$

$$P_{oc} = (1 - BT)(1 - P_{idle})(1 - a) \cdot p. \quad (4.19)$$

The  $P_c$  is the probability that a slot is wasted due to a collision among the tagged node and other nodes

$$P_c = app_n(1 - BT). \quad (4.20)$$

Finally,  $P_{bt}$  is the probability that a busy-tone signal is sensed per round

$$P_{bt} = [1 - ap_n(1 - p) - P_{idle}(1 - a) - ((1 - P_{idle})(1 - a)(1 - p) + (1 - P_{idle})(1 - a)p) - app_n] \cdot BT. \quad (4.21)$$

### 4.3.3 Delay Analysis

According to [104], the average time of a failed transmission round is:

$$E[\text{failed round duration}] = \frac{P_i + P_{os}E[T_s] + P_{oc}E[T_c] + P_{bt}E[T_s] + P_cE[T_c]}{1 - a(1 - p)(1 - BT)}, \quad (4.22)$$

and the average time of a successful round is:

$$E[\text{successful round duration}] = \frac{P_i + P_{os}E[T_s] + P_{oc}E[T_c] + P_{bt}E[T_s] + P_sE[T_s]}{a(1-p)(1-BT)}. \quad (4.23)$$

Therefore the average delay is equal to:

$$\text{delay} = n_a \times E[\text{failed round duration}] + E[\text{successful round duration}], \quad (4.24)$$

where

$$n_a = \sum_{n=0}^m np^n(1-p), \quad (4.25)$$

and  $m$  is the retransmission limit.

#### 4.4 Performance Study by Simulation

We present here the results of our analysis compared with discrete-event simulation results. The values of the system parameters used in both the simulations and the analysis are summarized in Table 4.1 and Table 4.2. The transmission range of the data and control packets for the wireless nodes is set to 150m while the transmission range of the busy-tone signal is set to 300m. The wireless nodes are distributed randomly using a two-dimensional *Poisson* distributions within an area of  $\pi(3 \times 150)^2$  m<sup>2</sup>. All nodes are equivalent and use omni-directional antennae in free space (no obstacles). In order to avoid the edge effect, we only considered the data collected from the nodes that are located in the center of the network, i.e., within 150 m from the center as shown in Fig. 4.3. Appendix B shows the C implementation for the node distribution used in our simulations. Nodes are loaded with CBR traffics with rates that are high enough to achieve traffic saturation. All simulation results are obtained with 95% confidence interval.

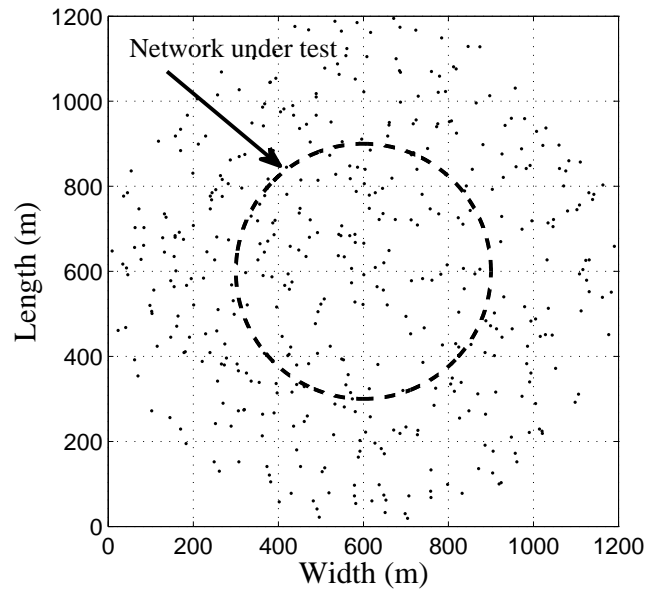

Figure 4.3: A randomly picked snapshot from simulation runs showing node distribution in the wireless network.

Table 4.1: EBTMA Physical parameters.

Parameter	Value
PHY	DSSS
$CW_{min}$	31
$CW_{max}$	1023
$m$	7
Channel data rate	11 Mbps
Basic data rate	1 Mbps
Propagation delay ( $\delta$ )	1 $\mu s$
Slot Time ( $\sigma$ )	20 $\mu s$
SIFS	10 $\mu s$
DIFS	50 $\mu s$

Table 4.2: EBTMA Packet parameters.

Parameter	Value
packet payload	12000 bits
MAC header	272 bits
PHY header	192 bits
ACK	304 bits
RTS	352 bits
CTS	304 bits

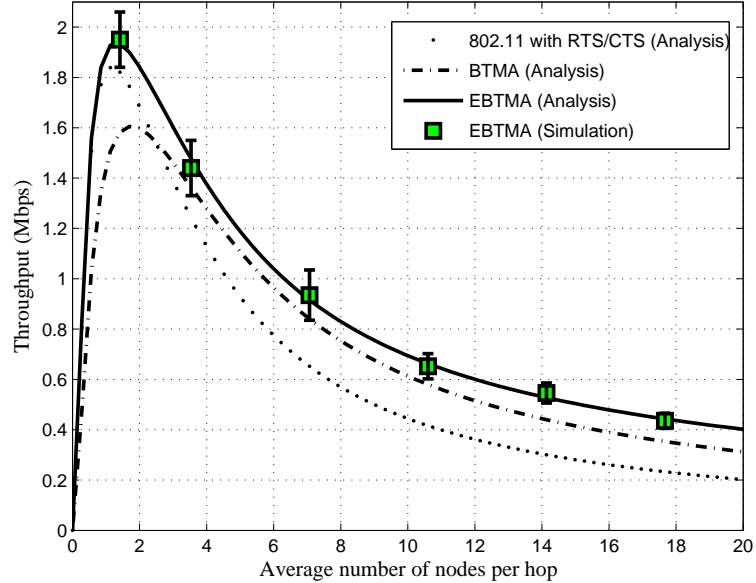

Figure 4.4: Per-hop throughput: analysis versus simulation.

The simulation and analysis results for EBTMA are compared in Fig. 4.4, which shows good agreement. The EBTMA performance is also compared with the those of the original 802.11 RTS/CTS protocol and the BTMA protocol.

As shown in the figure, the EBTMA can achieve a higher throughput than the previous solutions. The throughput of RTS/CTS only (without busy-tone) is higher than the throughput of BTMA when the node density is very low. This is because BTMA will block a larger number of wireless nodes by the busy-tone signal. However, when the node density increases, BTMA has a clear improvement in the throughput as a result of reducing hidden-terminal collisions. In general, the throughput reaches its peak as soon as the number of the wireless nodes is getting high enough for spatial reuse with concurrent transmissions, and it decays as the number of the wireless nodes further increases which results in higher collisions. We have also notice that, the shape

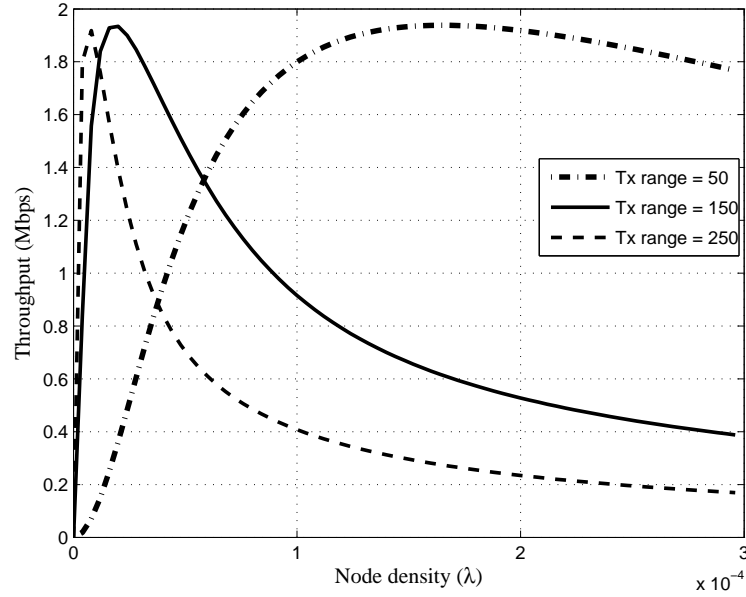

Figure 4.5: The shape and the peak position of the throughput.

and the peak position of the throughput is changing according to the transmission range as it is shown in Fig. 4.5. The proposed EBTMA scheme outperforms both BTMA and RTS/CTS schemes with both low and high traffic density.

We have also compared the delay results with the original RTS/CTS mechanism. According to Fig. 4.6, we can also notice that the delay with EBTMA is lower. The figure also shows a good agreement with the simulation results.

## 4.5 Chapter Summary

In this chapter, we present a new Enhanced Busy-tone Multiple Access (EBTMA) medium access control (MAC) protocol. The proposed protocol minimizes the negative impact of both the hidden-terminal and the exposed-terminal problems with the assistance of an out-of-band busy tone signal. The new protocol can also enhance

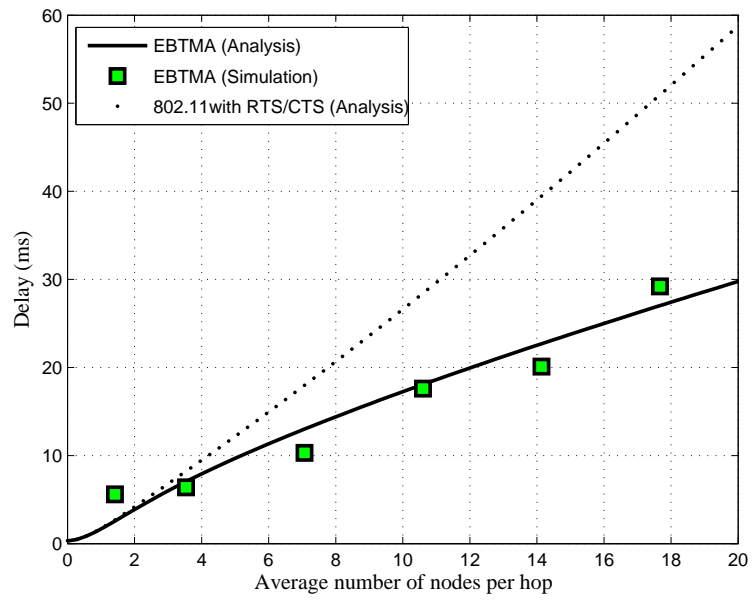

Figure 4.6: Per-hop Delay.

the reliability of packet broadcast and multicast which are very important for many network control functions such as routing. Unlike the previous busy-tone schemes, such as the original Busy-tone Multiple Access (BTMA) protocol, the proposed protocol uses a non-interfering busy-tone signal in a short period of time, in order to notify all hidden terminals without blocking a large number of nodes for a long time. The analysis verified by simulation results have shown that the proposed protocol has outperformed the existing MAC protocols and it can greatly improve the performance of wireless ad hoc networks. In addition, the proposed EBTMA protocol can co-exist with the existing 802.11 MAC protocol, so it can be incrementally deployed.

## Chapter 5

# DSDMAC: Dual Sensing Directional MAC Protocol

Using directional antennas, a higher antenna gain can be achieved which results in higher data rate, larger transmission range and/or less transmission power. There are many applications using directional antennas. Vehicular networks for example are a natural application since the vehicular traffic usually follows a straight line. When used in a network, directional antennas can reduce the number of blocked wireless nodes and allow more communications to take place concurrently. As a result, the throughput and the delay of the wireless network are improved thanks to the higher spatial reuse. However, effective MAC protocols to support directional antenna faces several challenges. Particularly, the hidden-terminal, exposed terminal and deafness problems severely affect the throughput and delay performance of the network.

Different from the situation with omni-directional antennas, hidden-terminals in networks using directional antennas are located near the source node, as they may not hear the source's transmissions and therefore, they may initiate transmissions which lead to collisions. Deafness, on the other hand, occurs when a targeted destination does not reply because it is transmitting or receiving at a different direction. If it

is not handled, failed transmissions due to deafness might be treated as collisions by the source node. Even worse, it may also lead the source node to conclude that the destination node is unreachable which severely affects the performance of the higher layer protocols. There are other problems that arise when applying some of the proposed solutions in the literature, such as the asymmetry-in-gain problem [6] and the exposed-terminal problem which are discussed in more details in section 5.1.

Using directional antennas in ad hoc networks poses challenging problems for MAC protocol design. The main contributions of this chapter are of threefold. First, we propose a Dual Sensing Directional MAC protocol (DSDMAC) for networks with directional antennas. The protocol helps to improve the throughput and delay performance of the wireless networks by minimizing the negative effect of the hidden-terminal, exposed-terminal and deafness problems. The protocol uses non-interfering out-of-band busy-tone signal combined with sensing the activity on the actual data channel to identify deafness situations and to avoid unnecessary blocking. In addition, the protocol avoids the asymmetry-in-gain problem introduced by other solutions. Second, the integrity of the DSDMAC protocol is verified using *Spin*, a formal protocol verification tool. Finally, a framework for throughput and delay analysis of wireless ad hoc networks using directional antennas is presented. The accuracy of the analysis is validated by simulation results, showing the advantages of applying the DSDMAC protocol. The results are also showing that the proposed DSDMAC protocol can outperform the state-of-the-art protocols by 15% to 184%.

The remainder of this chapter is organized as follows. In Section 5.1, we define the directional antennae MAC related problems and the proposed system model. The DSDMAC is introduced in Section 5.2, followed by validation plan and protocol validation in Section 5.3. The performance analysis and simulations in Section 5.4 and Section 5.5, respectively. Finally, the chapter summary and concluding remarks are given in Section 5.6.

## 5.1 Problem Definition and System Model

In this section, we define the directional antennae MAC related problems and the proposed system model.

### 5.1.1 The Hidden and Exposed Terminals Problem

Unlike the omni-directional counterpart, in directional antenna networks, the hidden-terminals are located close to the source node. Theoretically, all nodes that could be located within the destination node's coverage area and are away from the source node's coverage area are hidden-terminals. The shaded area  $A_h$  in Fig. 5.1 (a) indicates the area at which hidden-terminals may exist. Hidden-terminals can severely degrade the performance of wireless networks. Unfortunately, the standard RTS/CTS mechanism fails to completely solve the problem, as nodes in  $A_h$  may initiate transmissions during the time the source node transmits the RTS, as discussed in [104, 105].

The exposed-terminal problem needs more attention in directional antenna networks. For example, if using ORTS and/or OCTS, nodes will unnecessarily block the sectors that can be used for concurrent transmissions; thus it will waste the chance for higher spatial multiplexing gain which defeats the purpose of using directional antenna.

### 5.1.2 Deafness Problem

The deafness problem occurs when nodes use directional antennas in ad hoc networks. It happens when a source node fails to communicate with its intended destination which is pointing at a different direction for transmitting or receiving. For example, node  $E$  in Fig. 5.1 (b) is trying to communicate with node  $S$  while  $S$  is beamformed toward node  $D$ . As a result, node  $E$  will double its backoff time for retransmission,

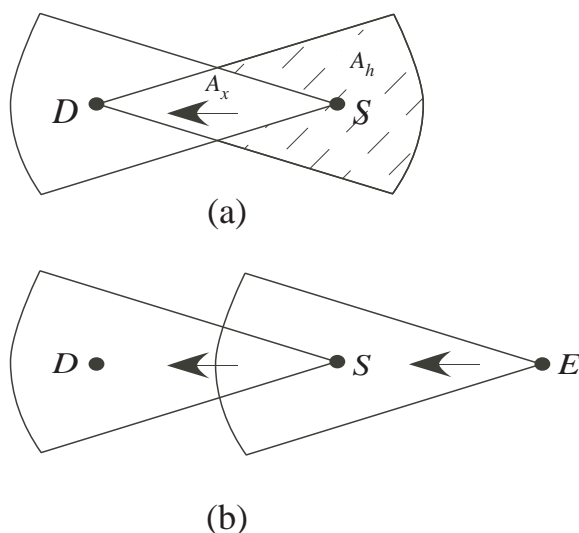

Figure 5.1: Directional antenna problems: (a) Hidden terminals. (b) Deafness.

as it concludes that a collision has occurred. Even worse, when node  $E$  reaches the retry limit, it concludes that node  $S$  is unreachable.

### 5.1.3 Locating Destination Direction

In order to choose the right antenna sector, the transmitting node needs to identify the right direction of its desired destination. One of the earliest methods suggested an Omni-directional RTS (ORTS) over an omni-directional antenna or over all available sectors of a directional antenna.

Upon receiving the ORTS, the receiver can identify the direction of the source node by detecting the direction of the antenna that has a maximum power. This can also serve as informing all other neighboring nodes about the incoming transmission. The receiver however still needs to inform its neighbors about this incoming transmission and hence it needs to reply using an Omni-directional CTS (OCTS). After that, the source and the destination nodes may proceed using the chosen sectors

to carry on their Directional DATA (DDATA) and Directional Acknowledgement (DACK) transmissions.

#### 5.1.4 Asymmetry-in-Gain Problem

When using two different types of antennas to transmit wireless signals, for example, a directional transmission for data packets and an omni-directional transmission for control packets such as RTS/CTS, different transmission ranges lead to the asymmetry-in-gain problem. The transmission range of a directed signal and the transmission range of an omni-directional radiated signal are not identical. As a result, the control packets transmitted omni-directionally will not reach all the desired nodes.

#### 5.1.5 Antenna Model

A directional antenna is thought of an antenna with a constant gain over a certain angle  $\Omega_A$  as shown in Fig. 5.2 (a).

Since we are interested in using the antenna in the azimuth plane, the radiation pattern presented in Fig. 5.2(b) depicts the main pattern attributes. The pattern consists of the main lobe at the direction of the maximum radiation intensity and other minor side-lobes. The half-power beamwidth (or simply beamwidth) is the angle between the edges in the main lobe that are down from the maximum gain by 3 dB.

In our antenna model, we assume an ideal antenna that has no side-lobes. According to Stutzman [106], the area size of the side-lobes are much smaller than the area size of the main-lobes. Therefore, the probability of finding wireless nodes within the side-lobes of the antenna is very small and can be ignored. The antenna has a constant gain within the beamwidth and zero outside. In order to cover all

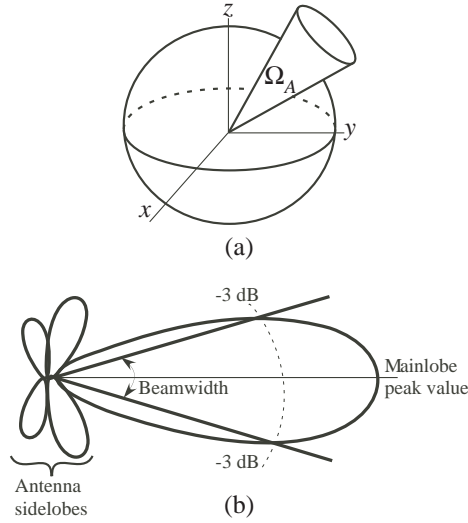

Figure 5.2: Antenna pattern: (a) Beam solid angle  $\Omega_A$ . (b) Antenna power pattern.

directions, we use  $S \times \Theta \geq 2\pi$ , where  $S$  is the number of antenna sectors and  $\Theta$  is the beamwidth of a single antenna sector as shown in Fig. 5.3(a). Sectors can be used simultaneously in order to provide an omni-directional receiving function as shown in Fig. 5.3(b), or they can be switched individually for a specific direction as shown in Fig. 5.3 (c). An antenna controller is assumed. The controller keeps track of the directions from which a maximum signal power is received. It then informs the higher layers about the sector of the received signal. The switching within the antenna controller can be achieved by using very fast analog CMOS multiplexers/demultiplexers which have a transition time less than 217 ns (Analog Devices, ADG5408/ADG5409, 4-/8-Channel Multiplexers). This transition time is less than the signal propagation delay. Therefore, the SIFS defined in the 802.11 standard [107] is long enough for the antenna being switched between transmitting and receiving modes. Data packets are transmitted using one sector, and the busy-tone signal may be transmitted rotationally one sector at a time over all available (non-blocked) sectors.

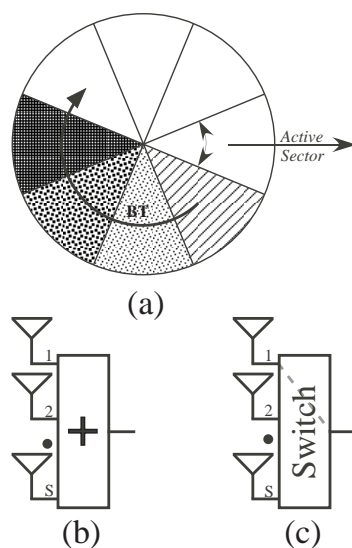

Figure 5.3: Directional antenna model: (a) Antenna sectors. (b) Omni-directional function. (c) Selecting a specific sector.

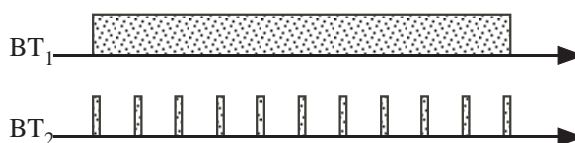

Figure 5.4: Busy-Tone signal patterns.

### 5.1.6 The Busy-Tone Signal

The busy-tone signal is a non-interfering sine-wave signal used to let other nodes be aware of an ongoing transmission. Two different patterns are used: a continuous pattern, which is referred to as  $BT_1$ , and an ON/OFF pattern, which is referred to as  $BT_2$ . The two patterns are depicted in Fig. 5.4.  $BT_1$  and  $BT_2$  are used for different purposes which will be discussed in more details in the following section. When more than one busy-tone signals are constructively interfering with each other, a fall-back to a  $BT_1$  is resulted.

## 5.2 Dual Sensing Directional MAC Protocol

The proposed Dual Sensing Directional MAC protocol (DSDMAC) uses two well-separated wireless channels: a data channel and a busy-tone channel. The data channel carries the data packets as well as the RTS, CTS and ACK packets on a specified direction (DRTS, DCTS, DDATA and DACK). On the other hand, the busy-tone channel will be used to transmit a sine-wave busy-tone signal on all other directions. Only the source and destination nodes will transmit the busy-tone signal. The protocol assumes that the directions of all reachable destinations or forwarders are predetermined (during the node discovery period for example).

### 5.2.1 Transmitting and Receiving with DRTS/DCTS

When the link layer of a wireless node receives data packets from its higher layer, it senses the activity on the data channel at the specified direction. If the specified sector is not blocked and the data channel is idle and no  $BT_1$  is present, it immediately transmits a DRTS packet and turns-on its  $BT_1$  signal at all other directions. In case a  $BT_1$  was sensed, other nodes should postpone any DRTS till  $BT_1$  disappears. Otherwise, the source node waits until the tagged sector is unblocked and becomes idle for the period of a distributed interframe space (DIFS). It then generates a random backoff interval before transmitting its DRTS packet. The backoff interval is chosen randomly in the range from 0 to  $CW - 1$ , where  $CW$  is the initial contention window size. The backoff counter is always frozen whenever the node senses an activity on the data channels at the specified direction or whenever the sector at the specified direction is blocked (e.g., by DRTS/DCTS from other nodes). Once the backoff counter reaches zero, the node transmits its DRTS packet at the specified direction and turns on its  $BT_1$  signal over all other directions. The source node should change

the  $BT_1$  to  $BT_2$  after finishing the DRTS packet transmission plus a short interframe space (SIFS) duration. We will discuss the reason for the BT switching shortly.

On the destination side, the receiving node (to which the DRTS packet is addressed) replies after an SIFS period with a DCTS packet at the specified direction and turns on its  $BT_2$  signal at all other directions. It then waits for the data packet. Once the data packet is received successfully, the destination node acknowledges it by sending a DACK packet at the same direction. After that, it turns off its busy-tone signal.

The main purpose of  $BT_1$  is to avoid the hidden-terminal problem. Because DRTS cannot be sensed by the nodes in the hidden terminal area ( $A_h$  in Fig. 5.1), these nodes can avoid initiating a new DRTS when they sense the  $BT_1$ . The  $BT_1$  can be turned off after the DRTS plus an SIFS because the nodes in  $A_h$  can sense the CTS to avoid collision.

The main purpose of  $BT_2$  is to solve the deafness problem. When a node is transmitting or receiving directionally, it will not be able to respond to other DRTS. When a source notices a failed DRTS, it should check whether there is a  $BT_2$  from the receiver's direction. If not, it concludes that there is a collision for the DRTS; otherwise, the receiver is busy in other transmissions. Therefore, if the source node does not receive a DCTS packet within a specified CTS-Timeout interval and it senses a  $BT_2$ , it reschedules the transmission of the packet for a later time (after the busy-tone has disappeared) without doubling its backoff CW; if there is no  $BT_2$  it reschedules the transmission of the packet for a later time and doubles its backoff CW.

Once the source node receives the DCTS successfully, it transmits the data packet directionally. After that, if the source node does not receive a DACK packet within a specified ACK-Timeout interval or it detects a transmission of a different packet, it reschedules the transmission of the data packet for a later time and doubles its

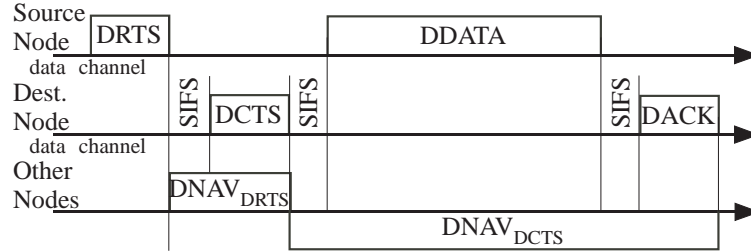

Figure 5.5: DNAV setting.

backoff CW.

### 5.2.2 Directional NAV Mechanism

When a node receives a valid DRTS packet, it should set its per sector Directional Network Allocation Vector (DNAV) timers. It also should block all of its sectors for a period with a duration of  $SIFS + DCTS$  as shown in Fig. 5.5. We call this time  $DNAV_{DRTS}$  time. Unless a DCTS packet is received, the node should unblock its antenna sectors when the  $DNAV_{DRTS}$  timer is expired. If a DCTS packet is received, then only the receiving sector and the sector from which a previously DRTS packet is received (if applicable) should remain blocked for a period with a duration of  $2 \times SIFS + DDATA + DACK$ , so the node will not initiate any transmissions to interfere the ongoing transmission. We call this time  $DNAV_{DCTS}$  time, as shown in Fig. 5.5. Using this DNAV design, we can minimize the exposed-terminal problem without increasing the collision probability.

### 5.2.3 Case Study and State Transitions of DSDMAC

To further illustrate how the DSDMAC meets its design goal, we use an example with the network configuration shown in Fig. 5.6. The source and the destination nodes ( $S$  and  $D$ ) are marked with solid dots. Nodes 1, 2, 3 and 4 are located on the

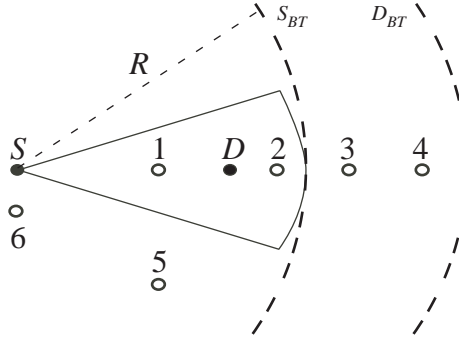

Figure 5.6: Case study.

same line connecting node  $S$  and node  $D$ . Nodes 5 and 6 are located at a different directions. The dashed curve  $S_{BT}$  marks the circular region of node  $S$ 's busy-tone signal range with a radius  $R$ . Likewise, the dashed curve  $D_{BT}$  marks the circular range of node  $D$ 's busy-tone signal. The message exchanges among these nodes are shown in Fig. 5.7, where the arrow within each packet indicates the direction used to transmit that packet.

As shown in Fig. 5.7, node  $S$  waits until nodes 1 and 2 finish their communication. Meanwhile, nodes 3 and 4 may start their communication independently because the direction from node 3 to node 4 is not blocked. When node  $S$  senses no  $BT_1$  in the busy tone channel, no new activities in the data channel, and its corresponding antenna sector toward  $D$  is not blocked, it starts its transmission to node  $D$  after a backoff period. Any further transmission from node 1 to node 2 must be deferred till node  $S$  finishes. However, node 5 can start its transmission toward node 2 independently because the direction from node 5 to node 2 is not blocked. As a hidden-terminal, node 6 will be blocked from transmission while it hears the  $BT_1$  from  $S$ , and it will then receive the  $D$ 's DCTS and avoid collisions.

The state transition diagram for the DSDMAC protocol is shown in Fig. 5.8. Although the states are self-explanatory, the following highlights the most important

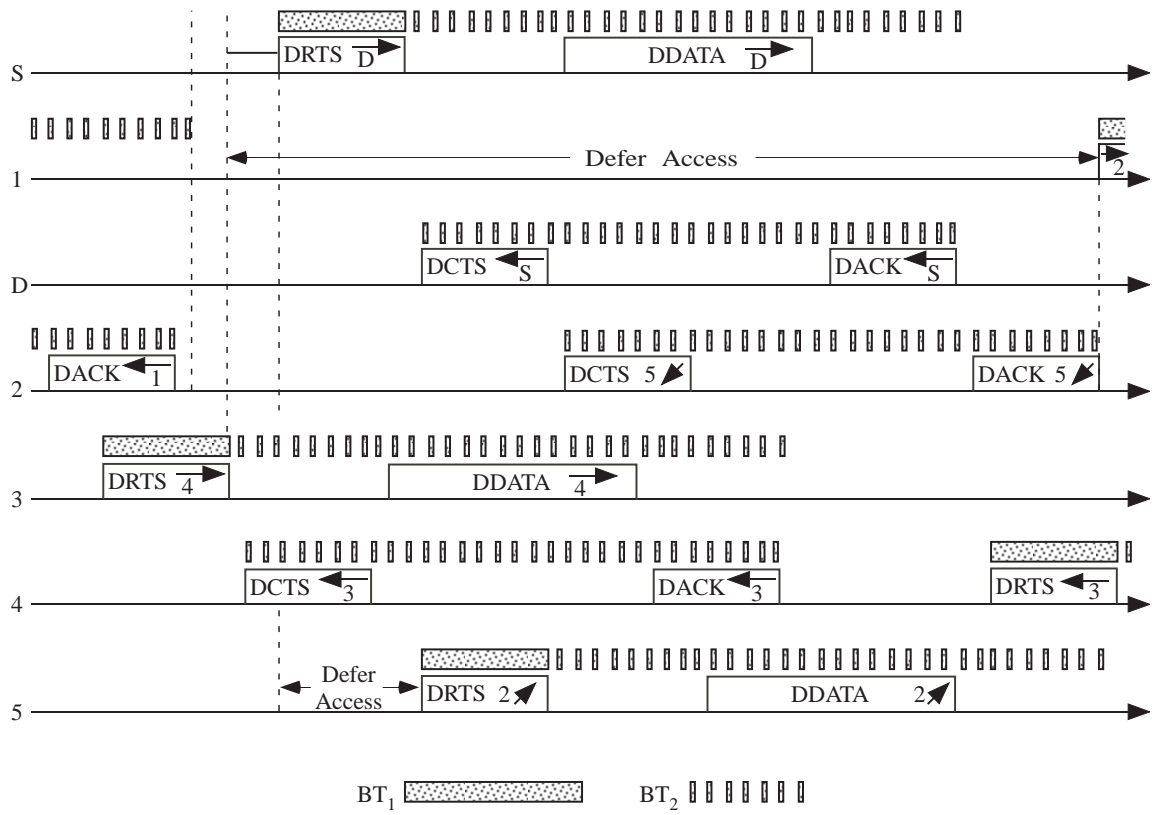

Figure 5.7: DSDMAC: DRTS/DCTS/DDATA/DACK and BT setting.

states which are different from the IEEE 802.11 MAC protocol [107]. The system is initially in its idle state until a packet arrives from the higher layers or a packet arrives from another node. When a packet arrives from the higher layers, there is no new activity in the data channel, no  $BT_1$  is sensed, and the corresponding antenna sector is not blocked, the system moves to the “Send DRTS & start BT” state and sets a timer to wait for the DCTS; otherwise, the system moves to the “Wait” state till the channels become idle and the sector is unblocked, then it moves to the “Backoff” state.

In case the timer expired without receiving a DCTS packet and a  $BT_2$  signal is presented, the system skips the “Double backoff counter” state, as it concludes that its destination might be busy towards other directions. In this case, the system will directly go to the “Wait” state. This transition helps the DSDMAC protocol to avoid the deafness problem.

### 5.3 Validation Plan and Protocol Validation

The validation of the DSDMAC protocol is carried out using a popular open-source tool called Simple Promela INterpreter (*Spin*) which analyzes PROtocol/PROcess MEta LAnguage (*Promela*) code to detect design errors such as deadlocks and other violations.

In order to examine whether the DSDMAC protocol meets the suggested requirements, such as freedom from deafness, a traversal exploration through the state space generated by the DSDMAC protocol (shown in Fig. 5.8) is required. When the applied model is complex, the state explosion problem will be encountered. Therefore, we have applied validation techniques such as the partial state exploration to reduce the complexity [108].

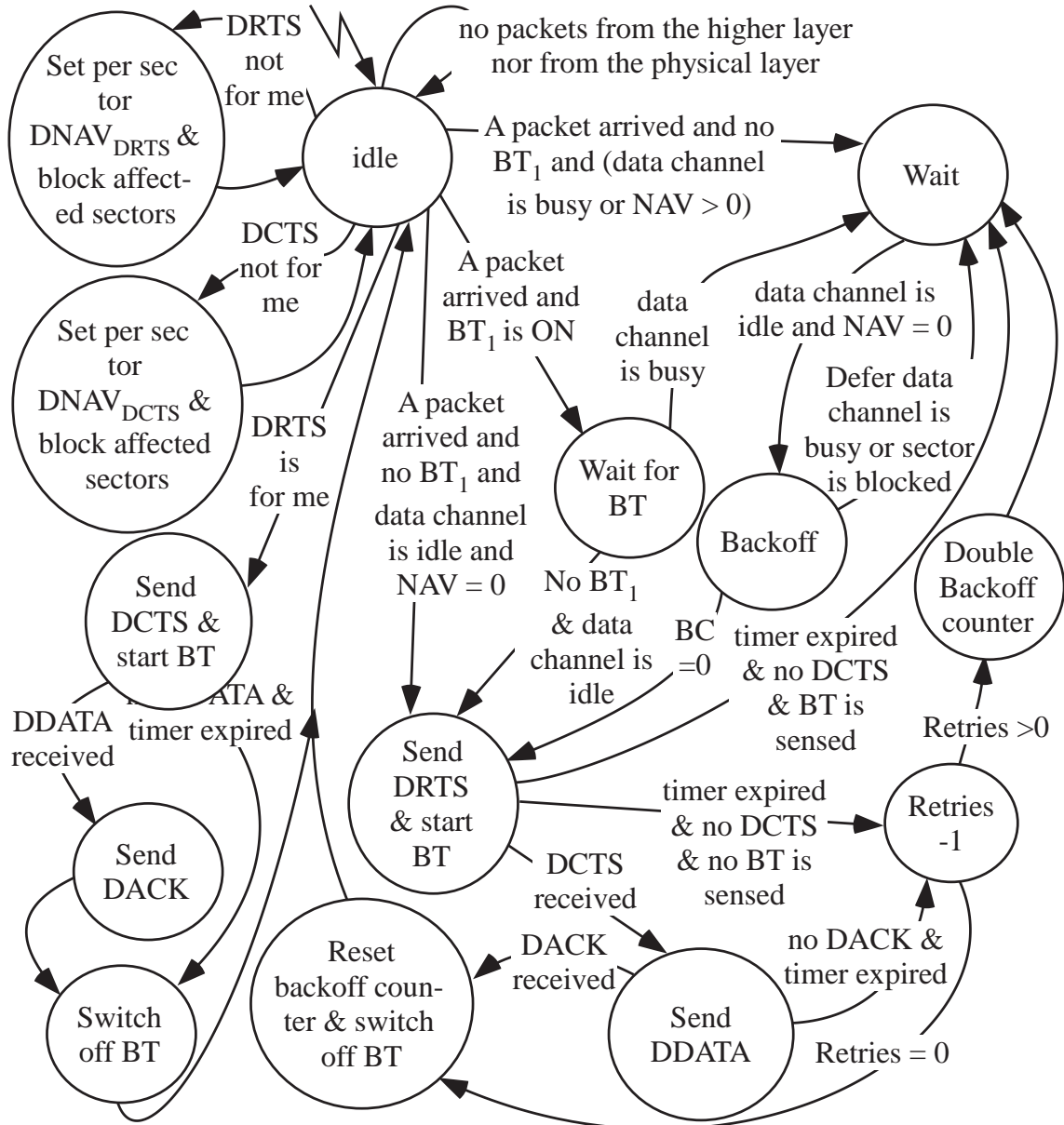

Figure 5.8: DSDMAC system state transition diagram.

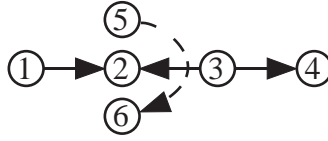

Figure 5.9: A sample network used for validation.

Promela is designed specifically to model network protocols and multi-threaded programs. For the purpose of validating the DSDMAC protocol, we have modeled our network using a limited number of wireless nodes in order to reduce the network state space. This should not affect the integrity of the validation process since the properties that we are willing to test mainly depend on the locations of the wireless nodes rather than the size of the network. Fig. 5.9 shows a sample network used for our validation process. The solid circles represent the wireless nodes and the arrows represent the traffic flow direction.

As an example, in the following we demonstrate how to use *Spin* to verify whether the existing and the proposed MAC protocols are deafness-free and blocking-free. In order to verify the deafness-free property, given the wireless nodes are allocated precisely at locations that guarantee no collisions nor hidden-terminal situations, an RTS packet should always be followed by a CTS or by hearing a busy-tone signal. This can be written in a formal temporal claim as

$$\Box(\text{RTS} \diamond (\text{BT} \parallel \text{CTS})),$$

and read as: always RTS then eventually BT or CTS. A similar formula can be introduced to capture the blocking situations. Let  $D_{xy}$  denote a directional transmission from node  $x$  to node  $y$  and let  $B_{xy}$  denote a blocked direction from

node  $x$  to node  $y$ . A blocking claim can be expressed as:

$$\begin{aligned} & \square(D_{12} \square(B_{34} \parallel B_{56})) \\ & \square(D_{34} \square(B_{12} \parallel B_{56})) \\ & \square(D_{56} \square(B_{12} \parallel B_{34} \parallel B_{32})). \end{aligned}$$

Spin results are summarized in Table 5.1. The results show that transmitting the RTS/CTS omni-directionally in DMAC protocol can block node 5 from transmission when node 1 or node 3 starts a transmission to node 2. Deafness situations are also likely occurring if node 3 misses node 2's CTS. The MMAC has also failed the test. The omni-directional reception of the RTS packets as stated by the protocol will block node 6 from receiving node 5's RTS when node 1 transmits toward node 2. In addition, the deafness situation occurs when node 3 tries to send a packet to node 2 while node 2 is receiving from node 1. The ToneDMAC on the other hand shows good results on handling the blocking problem. However, according to the discussion in section 2.3.2, deafness situations are not completely eliminated. The DBTMA/DA protocol is vulnerable to the blocking problem since a source node is prevented from transmission at the presence of  $BT_r$  signal. Deafness however was not reported. Finally, the validation results show that DSDMAC can handle both deafness and blocking as expected, and thus it outperforms the other protocols. Next, we develop an analytical framework to quantify the protocol performance.

## 5.4 Performance Analysis

In this section, we develop the analytical models to quantify the throughput and the delay in a wireless network using directional antennas. In our analysis, we make the following assumptions. All wireless nodes are identical and equipped with the same type of antennas. Each node has  $S$  antenna sectors which can be switched individually towards a specific direction or they can be summed together for an omni-directional

Table 5.1: SPIN verification results.

Protocol	Blocking-free	Deafness-free
DMAC[94]	Not valid	Not valid
MMAC[70]	Not valid	Not valid
Tone DMAC[84]	Valid	Not valid
DBTMA/DA[87]	Not valid	Valid
DSDMAC	Valid	Valid

reception. It is also assumed that a busy-tone signal can be transmitted over all of the unused sectors during communications. Nodes are randomly distributed according to a *Poisson* distribution in a two-dimensional space, and all active nodes are saturated, i.e., their data buffers are always non-empty.

#### 5.4.1 Throughput Analysis

Given the exponential backoff strategy used in the MAC protocol, we first apply Bianchi's equation for the packet transmission probability [7].

$$a(p) = \frac{1}{1 + \frac{1-p}{1-p^{m+1}} \sum_{i=0}^m p^i E[b_i]}, \quad (5.1)$$

where  $p$  is the packet collision probability,  $m$  is the maximum number of backoff stages and  $E[b_i] = CW_i/2$  is the average value of the backoff counter in stage  $i$ . The reader may refer to [7] for detailed derivation of (5.1).

Different from Bianchi's work and its many follow-up works, the challenging part here is that we need to consider the more complicated situations associated with directional antenna. We assume that an active node chooses a sector (a direction) with probability  $1/S$ . For a sensing slot, the tagged node chooses one sector at a time and is ready to transmit toward its destination with a probability of  $a$ , while other

nodes are ready to transmit toward the same destination with a probability of  $a/S$ . Therefore, the probability that none of the other nodes is ready to transmit is given by:

$$P_0 = \sum_{i=2}^{\infty} \left(1 - \frac{a}{S}\right)^{i-1} \frac{(\lambda A_S)^i}{i!} e^{-\lambda A_S}, \quad (5.2)$$

where  $\lambda$  is the node density in the network and  $A_S \approx \frac{\pi R^2}{S}$  is the sector area. Apart from the tagged node, the probability that one of the other wireless nodes is ready to transmit toward the destination node direction is given by:

$$P_1 = \sum_{i=2}^{\infty} (i-1) \cdot \frac{a}{S} \cdot \left(1 - \frac{a}{S}\right)^{i-2} \frac{(\lambda A_S)^i}{i!} e^{-\lambda A_S}. \quad (5.3)$$

The wireless channel within the chosen sector is either idle, or occupied by a successful or collided transmission. The channel is idle when none of the other nodes nor the tagged node is ready to transmit or there was less than two nodes in the area. Therefore, the idle probability is given by:

$$P_{idle} = (1-a)P_0 + (1-p_n) - (1-a)(1-p_n)P_0, \quad (5.4)$$

where

$$p_n = 1 - (1 + \lambda \pi R^2) e^{-\lambda \pi R^2} \quad (5.5)$$

is the probability of finding two or more wireless nodes within the area. A successful transmission, however, occurs when either one of the other nodes or the tagged node are transmitting successfully which is given by:

$$P_s = aP_0p_n + (1-a)P_1p_n. \quad (5.6)$$

Finally the collision probability is given by:

$$p = (1 - P_0 - P_1)p_n + aP_1p_n. \quad (5.7)$$

We define the per-hop throughput as the total throughput within a circle area centered at the tagged node and with radius equal to its transmission range. Once the value of  $a$  is computed using (5.1), the per-hop throughput can be computed as:

$$Th = \frac{P_{tr}E[P]'}{E[\text{Slot}]}, \quad (5.8)$$

where

$$E[P]' = E[P](1 + 1/CWmin) \quad (5.9)$$

is the average amount of payload bits  $P$  transmitted in one slot  $\sigma$  [7],

$$P_{tr} = a(1 - p)p_n \quad (5.10)$$

is the success probability of the tagged node, and

$$E[\text{Slot}] = P_{idle}\sigma + P_sT_s + pT_c. \quad (5.11)$$

The values  $\sigma$ ,  $T_s$  and  $T_c$  are the periods of an empty slot, the time required to successfully transmit a data packet and the wasted time due to a collision, respectively. They are protocol dependent. For instance, considering the IEEE 802.11 standard with RTS/CTS enabled, we have:

$$\begin{aligned} T_s = & DRTS + SIFS + \delta + DCTS + SIFS + \delta + H \\ & + E[P] + SIFS + \delta + DACK + DIFS + \delta \end{aligned} \quad (5.12)$$

$$T_c = DRTS + DIFS + \delta, \quad (5.13)$$

where  $DRTS$ ,  $DCTS$  and  $DACK$  are the transmission durations of directional RTS, CTS and ACK packets, respectively,  $\delta$  is the propagation delay, and  $H$  and  $P$  are the transmission durations of the packet header (PHY and MAC headers) and the packet payload, respectively.

### 5.4.2 MAC Delay Analysis

As in [104], we define the MAC delay as the time required for transmitting a data packet from the time it reaches the MAC sublayer (excluding queuing delay) to the moment it is received successfully. A packet transmission may involve up to  $m$  trials (where  $m$  is the maximum retry limit) till it can be successfully transmitted. Let  $n_a$  be the average number of unsuccessful attempts. We have:

$$n_a = \frac{\sum_{n=0}^m n(1 - P_{tr})^n}{\sum_{n=0}^m (1 - P_{tr})^n}, \quad (5.14)$$

We call each transmission attempt as a round and each round can be divided into a number of slots. A slot can be either idle or busy for a successful/unsuccessful transmission. A failed round consists of a number of idle slots, a number of successful and unsuccessful slots by other nodes, and ended with a failed slot by the tagged node. A successful round is ended with a successful transmission by the tagged node. Since each round ends with a transmission slot by the tagged node, the average number of slots per round is given by:

$$s = \sum_{i=0}^{\infty} i(1 - a)^i a = \frac{1}{a} - 1, \quad (5.15)$$

where  $a$  here is the probability that the tagged node is ready to transmit. Finally, the MAC delay is given by the average duration of a round ( $sE[\text{Slot}]$ ) multiplied by the average number of rounds ( $n_a + 1$ ):

$$\text{delay} = (n_a + 1)sE[\text{Slot}]. \quad (5.16)$$

## 5.5 Performance Evaluation

In this section we compare our analysis results with simulation results using a discrete event simulator. The system parameters used in both the simulations and

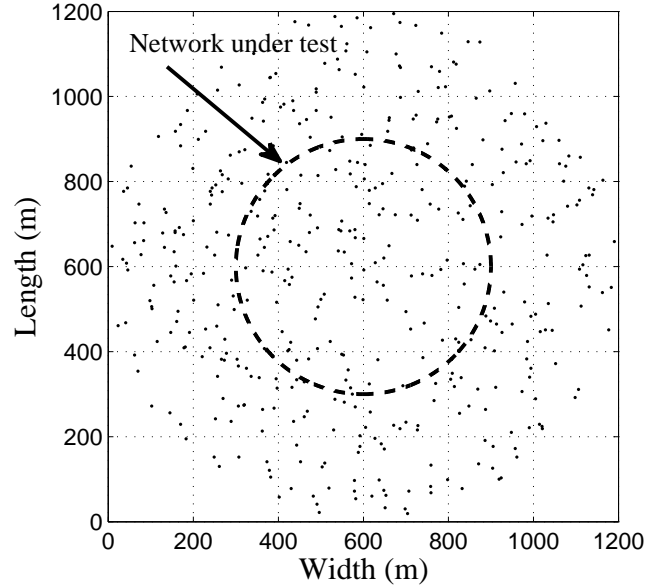

Figure 5.10: A randomly picked snapshot from simulation runs showing node distribution in the wireless network.

the analysis are summarized in Table 5.2 and Table 5.3. The wireless nodes are distributed randomly in a circular area with radius of 300 m (which is twice of the transmission range) according to a two-dimensional *Poisson* distribution. All nodes are identical and use directional antennas in free space (no obstacles). In order to avoid the edge effect, we only considered the data collected from the nodes that are located in the center of the network, i.e., within 150 m from the center as shown in Fig. 5.10. Appendix B shows the C implementation for the node distribution used in our simulations. The wireless nodes are loaded with CBR traffic with rates high enough to achieve traffic saturation.

In the following, we first compare the performance of DSDMAC protocol for nodes with directional antennas with that of the standard IEEE 802.11 DCF protocol for nodes with omni-directional antennas, in terms of per-hop throughput and MAC

Table 5.2: DSDMAC Physical parameters.

Parameter	Value
PHY	DSSS
$CW_{min}$	31
$CW_{max}$	1023
$m$	7
Channel data rate	11 Mbps
Basic data rate	1 Mbps
Propagation delay ( $\delta$ )	1 $\mu s$
Slot Time ( $\sigma$ )	20 $\mu s$
SIFS	10 $\mu s$
DIFS	50 $\mu s$

delay. Then, we compare the performance of DSDMAC and other directional MAC protocols.

The per-hop throughputs with different number of antenna sectors are presented in Fig. 5.11. The lines are the analytical results and the error bars represent the 95% confidence intervals of the simulation results. First, the accuracy of the analysis is validated by the simulation. Second, the results show that, with DSDMAC, more antenna sectors per node can result in a higher throughput. This is attribute to the reduction in the collision probabilities when more antenna sectors are used, as shown in Fig. 5.12.

In addition, given the DSDMAC protocol can appropriately deal with the deafness, hidden-terminal and exposed terminal problems, much higher throughput can be achieved in a dense network, thanks to the spatial multiplexing gain by using the directional antennas. As shown in Fig. 5.11, when the node density is above 2

Table 5.3: DSDMAC Packet parameters.

Parameter	Value
packet payload	12000 bits
MAC header	272 bits
PHY header	192 bits
ACK	304 bits
RTS	352 bits
CTS	304 bits

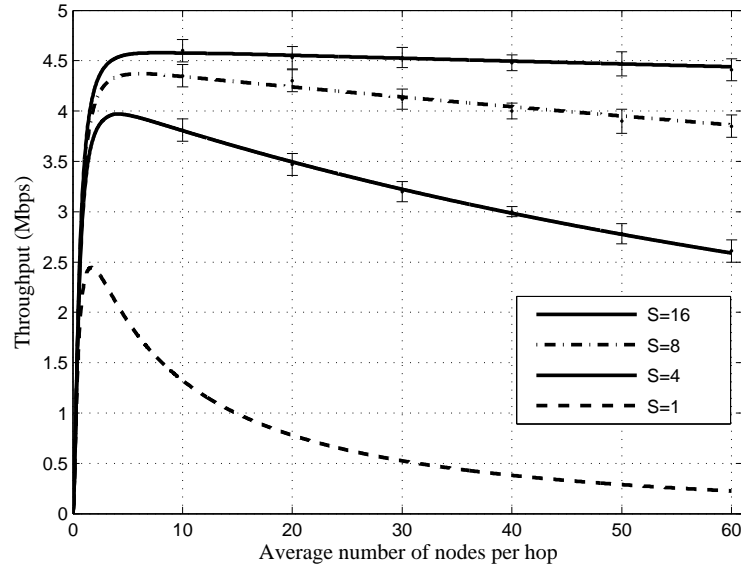

Figure 5.11: Per-hop throughput, using 1, 4, 8 and 16 antenna sectors. Lines: analytical results; error bars: 95% confidence intervals of simulation results.

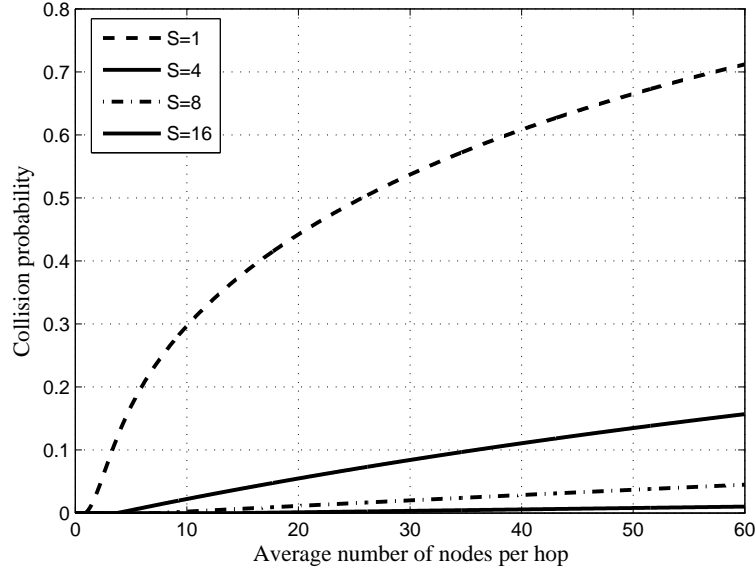

Figure 5.12: Collision probabilities, analysis results.

(nodes per hop), the throughput of “ $s = 1$ ” (with IEEE 802.11 DCF) decreases fast; while the throughputs of “ $s = 4, 8, 16$ ” (with DSDMAC) are more than twice higher at the density of 10 (nodes per hop), and the gaps are even larger when we further increase the density. Given the ever-increasing demand of wireless services and the ever-dense wireless networks, it is desirable to adopt the proposed DSDMAC protocol to support directional transmission and reception in dense wireless networks.

The proposed DSDMAC is further compared with the state-of-the-art directional MAC protocols using the same network settings as in [84]. The results presented in Table 5.4 are the aggregated throughput of 5 flows averaged from 25 runs. The network consists of 30 nodes placed randomly in a region of  $1500 \times 1500$  m<sup>2</sup> loaded with 512 Bytes packet size CBR traffic. The source-destination node-pairs are chosen randomly with the transmission range set to 300 m and the data rate set to 11 Mbps. The results in the table are presented in Mbps and shows that our proposed

Table 5.4: Aggregate CBR Multihop Throughput.

DSDMAC	ToneDMAC [84]	ZeroTone [84]	MMAC [70]	C-DMAC [98]
5.4	4.7	4.1	3.2	1.9

protocol can outperform, by 15% to 184%, the following directional MAC protocols: ToneDMAC [84], ZeroTone [84], MMAC [70] and C-DMAC [98]. In addition, we believe that when the node density is getting higher, our proposed protocol can have even higher performance gain, as our protocol is the only one not affected by the blocking and deafness problems according to the validation results in Table 5.1.

With the proposed DSDMAC, the delay can also be improved by increasing the number of antenna sectors. Fig. 5.13 shows the delay versus the average number of nodes using one, four, eight and sixteen antenna sectors. The figure shows that in addition to the higher throughput, a smaller MAC delay can be achieved using DSDMAC with directional antennas. While the average delay exceeds 350 ms for the wireless nodes equipped with omni-directional antennas, the average delay remains below 150 ms when using four or more antenna sectors and applying the DSDMAC protocol.

In summary, if the MAC protocol is well designed to mitigate the deafness, hidden-terminal and exposed-terminal problems, we can use directional antennas to achieve the spatial multiplexing gain and thus results in a higher network throughput and a lower delay.

## 5.6 Chapter Summary

In this chapter, we presented a new MAC protocol called Dual Sensing Directional MAC (DSDMAC) protocol for wireless ad hoc networks with directional antennas.

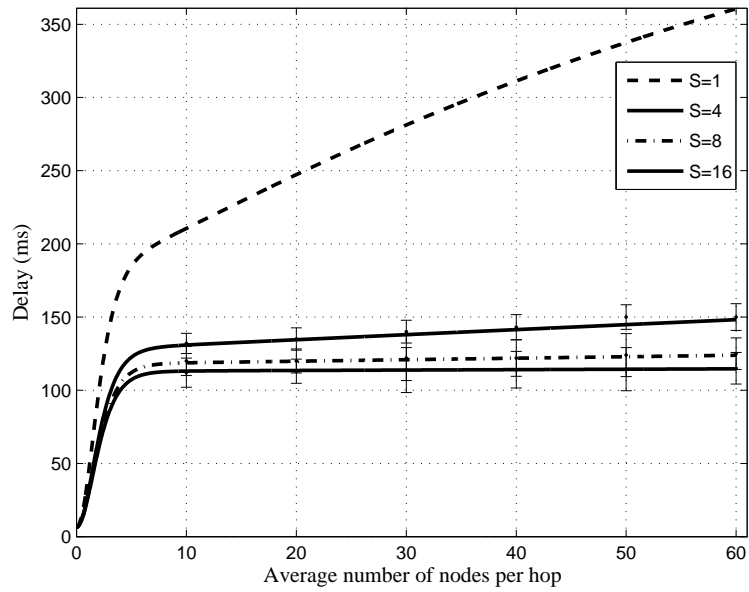

Figure 5.13: MAC delay with 1, 4, 8 and 16 antenna sectors. Lines: analysis results; error bars: 95% confidence intervals of simulation results.

Different from the existing protocols, the DSDMAC protocol relied on dual sensing strategy to identify deafness, resolve the hidden-terminal problem and avoid unnecessary blocking. The integrity of the DSDMAC protocol has been verified and validated using *Spin*, a formal protocol verification and validation tool. The chapter has further developed an analytical framework to quantify the performance of the DSDMAC protocol, and conducted extensive simulations which verified the accuracy of the analysis. The protocol verification, analysis, and simulation results have shown the robustness and superior performance of the DSDMAC protocol which can achieve a much higher network throughput and lower delay utilizing the spatial multiplexing gain of the directional antennas. The results have also shown that the proposed DSDMAC protocol outperformed the state-of-the-art protocols by 15% to 184%.

## Chapter 6

# Summary, Contributions and Future Work

This chapter summarizes this dissertation and lists the major research contributions. In our research work we studied in details the MAC performance in wireless multihop ad hoc networks. New protocols have been proposed to overcome the hidden and exposed terminal problems, deafness and other issues in existing protocols. The EBTMA protocol has been developed to overcome the hidden-terminal and the exposed-terminal problems that naturally exist in wireless multihop ad hoc networks. The DSDMAC protocol on the other hand has been designed to achieve a higher spatial multiplexing gain and thus higher network throughput using directional antennas. Some very important results were also presented within context.

### 6.1 Dissertation Summary

This section summarizes the research work presented in the dissertation.

In Chapter 2, we have provided some literature review for the performance analysis of the wireless multihop ad hoc networks. It then reviewed the busy-tone-assisted solutions that are proposed for overcoming the hidden-terminal problem.

Finally, the MAC protocols for ad hoc networks with directional antennas have been reviewed.

In Chapter 3, we have proposed simple yet accurate analytical models to compute the saturation throughput and delay in wireless multihop ad hoc networks. The models have been extended to investigate the realistic importance of signal to interference ratio. The analytical results have revealed two important issues. First, the impact of adjusting the transmission range on the throughput and delay have been quantified. The other, the hidden terminal region is closely related to the distance between the transmitter and the receiver. Thus, it is possible to adjust the transmission range to optimize the whole network performance. These models are general to be applied to study many wireless MAC protocols and applications, and their results would provide important guidelines for network planing and protocol optimization in wireless multihop ad hoc networks.

In Chapter 4, we have proposed a new Enhanced Busy-tone Multiple Access (EBTMA) medium access control (MAC) protocol to minimize the negative impact of both the hidden-terminal and the exposed-terminal problems. The new protocol can also enhance the reliability of packet broadcast and multicast which are very important for many network control functions such as routing. Different from other busy-tone assisted MAC protocols, the protocol uses a non-interfering busy-tone signal in a short period of time, in order to notify all hidden terminals without blocking a large number of nodes for a long time. In addition, the proposed EBTMA protocol can co-exist with the existing 802.11 MAC protocol, so it can be incrementally deployed.

Finally, in Chapter 5, we have proposed a new MAC protocol called Dual Sensing Directional MAC (DSDMAC) for wireless multihop ad hoc networks using directional antennas. The new protocol differs from the existing ones by relying on the dual sensing strategies to identify deafness, resolve hidden-terminal problem and avoid

unnecessary blocking. The results have shown that applying the DSDMAC protocol can greatly improve the performance of wireless networks using directional antennas.

## 6.2 Contributions

The major contributions of this research work can be summarized as follow:

### 6.2.1 Performance Analysis of Wireless Multihop Ad Hoc Networks

We have provided analytical models that allow quantifying the throughput and the delay in the wireless multihop ad hoc networks. The models consider the hidden-terminal problem analysis for networks with randomly distributed wireless nodes. This contribution has been first published in [104]. The model then has been enhanced by including hidden-terminal interference analysis.

### 6.2.2 Enhanced Busy-Tone-Assisted MAC Protocol for Wireless Ad Hoc Networks

We have proposed a new Enhanced Busy-tone Multiple Access (EBTMA) medium access control (MAC) protocol. The proposed protocol minimizes the negative impact of both the hidden-terminal and the exposed-terminal problems with the assistance of an out-of-band busy tone signal. The new protocol can also enhance the reliability of broadcast and multicast transmissions which are very important for many network control functions such as routing. This work has been published in [105].

### 6.2.3 DSDMAC: Dual Sensing Directional MAC Protocol for Ad Hoc Networks with Directional Antenna

We have also developed a new MAC protocol called Dual Sensing Directional MAC (DSDMAC) protocol for wireless ad hoc networks with directional antennas. Different

from the existing protocols, the DSDMAC protocol relies on dual sensing strategy to identify deafness, resolve the hidden-terminal problem and avoid unnecessary blocking.

## **6.3 Directions for Future Work**

This research work can be extended along the following research directions.

### **6.3.1 Future Work 1**

Based on the analysis provided in Chapter 3, first, it is possible to extend the analytical framework for obtaining the end-to-end flow throughput and delay in multihop networks. Second, the analysis focuses on the packet losses due to contention and ignore the channel fading and shadowing effects, which can be incorporated in the analytical model when calculating the successful transmission probability.

### **6.3.2 Future Work 2**

The DSDMAC protocol presented in Chapter 5 assumes that the directions of all reachable destinations or forwarders are predetermined during the node discovery period. It is possible to extend the functionality of the DSDMAC to include a directional routing protocol optimized for achieving the highest possible performance.

### **6.3.3 Future Work 3**

As mentioned in Section 3.2.3, mobility was not the scope of this dissertation. However, it is possible for the MAC protocols to collaborate with lower and higher layers in order to solve mobility problems. For instance, the MAC layer can collaborate with the physical layer to provide the routing layer with the speed and

direction of the wireless node. This would allow the routers to predict the possible change in node location.

## Bibliography

- [1] P. Chen, B. O’Dea, and E. Callaway, “Using optimum transmission range to design energy efficient systems for the neuRFon<sup>TM</sup> netform,” in *The 8th International Conference on Communication Systems*, vol. 2, 25-28 Nov. 2002, pp. 846–851.
- [2] Y. Wang and J. Garcia-Luna-Aceves, “Collision Avoidance in Multi-hop Ad Hoc Networks,” in *Proceedings. 10th IEEE International Symposium on Modeling, Analysis and Simulation of Computer and Telecommunications Systems*, 11-16 Oct. 2002, pp. 145–154.
- [3] H. Takagi and L. Kleinrock, “Optimal Transmission Ranges for Randomly Distributed Packet Radio Terminals,” *IEEE Transactions on Communications*, vol. 32, no. 3, pp. 246–257, Mar 1984.
- [4] D. Parsons, *The Mobile Radio Propagation Channel*. New York: Halsted Press (Division of Wiley), 1992.
- [5] F. Tobagi and L. Kleinrock, “Packet Switching in Radio Channels: Part II—The Hidden Terminal Problem in Carrier Sense Multiple-Access and the Busy-Tone Solution,” *IEEE Transactions on Communications*, vol. 23, no. 12, pp. 1417–1433, Dec 1975.

- [6] G. Jakllari, I. Broustis, T. Korakis, S. Krishnamurthy, and L. Tassiulas, "Handling asymmetry in gain in directional antenna equipped ad hoc networks," in *PIMRC 2005. IEEE 16th International Symposium on*, vol. 2, sept. 2005, pp. 1284–1288.
- [7] G. Bianchi, "Performance analysis of the IEEE 802.11 distributed coordination function," *Selected Areas in Communications, IEEE Journal on*, vol. 18, no. 3, pp. 535–547, Mar. 2000.
- [8] A. Kumar, E. Altman, D. Miorandi, and M. Goyal, "New insights from a fixed point analysis of single cell IEEE 802.11 wlans," in *INFOCOM 2005. 24th Annual Joint Conference of the IEEE Computer and Communications Societies. Proceedings IEEE*, vol. 3, 13-17 Mar. 2005, pp. 1550–1561.
- [9] P. Chatzimisios, V. Vitsas, and A. Boucouvalas, "Throughput and delay analysis of IEEE 802.11 protocol," *Networked Appliances, 2002. Liverpool. Proceedings. 2002 IEEE 5th International Workshop on*, pp. 168–174, Oct. 2002.
- [10] L. X. Cai, X. Shen, L. Cai, J. Mark, and Y. Xiao, "Voice capacity analysis of WLAN with un-balanced traffic," *IEEE Trans. on Vehicular Technology*, vol. 55, no. 3, pp. 752–761, May 2006.
- [11] H. Zhai and Y. Fang, "Performance of wireless lans based on IEEE 802.11 mac protocols," in *Proc. 14th IEEE on Personal, Indoor and Mobile Radio Communications PIMRC 2003*, vol. 3, 7–10 Sept. 2003, pp. 2586–2590.
- [12] M. Carvalho and J. Garcia-Luna-Aceves, "Delay analysis of IEEE 802.11 in single-hop networks," in *Proc. 11th IEEE International Conference on Network Protocols*, 4–7 Nov. 2003, pp. 146–155.

- [13] F. Gebali, “IEEE 802.11 wireless protocol: user performance using discrete-time Markov chains,” in *Circuits and Systems, 2003. MWSCAS’03. Proceedings of the 46th IEEE International Midwest Symposium on*, vol. 1, 27–30 Dec. 2003, pp. 459–462.
- [14] M. Garetto, J. Shi, and E. W. Knightly, “Modeling media access in embedded two-flow topologies of multi-hop wireless networks,” in *Proceedings of the 11th annual international conference on Mobile computing and networking, Cologne, Germany*, ser. MobiCom ’05. ACM, 2005, pp. 200–214.
- [15] S. C. Liew, C. H. Kai, H. C. Leung, and P. Wong, “Back-of-the-envelope computation of throughput distributions in csma wireless networks,” *IEEE Transactions on Mobile Computing*, vol. 9, no. 9, pp. 1319–1331, 2010.
- [16] D. Malone, K. Duffy, and D. Leith, “Modeling the 802.11 distributed coordination function in nonsaturated heterogeneous conditions,” *Networking, IEEE/ACM Transactions on*, vol. 15, no. 1, pp. 159–172, feb. 2007.
- [17] F. Alizadeh-Shabdiz and S. Subramaniam, “Analytical models for single-hop and multi-hop ad hoc networks,” in *Proc. First International Conference on Broadband Networks BroadNets 2004*, 2004, pp. 449–458.
- [18] S. Khurana, A. Kahol, S. Gupta, and P. Srimani, “Performance evaluation of distributed co-ordination function for IEEE 802.11 wireless lan protocol in presence of mobile and hidden terminals,” in *Proc. 7th International Symposium on Modeling, Analysis and Simulation of Computer and Telecommunication Systems*, 24–28 Oct. 1999, pp. 40–47.
- [19] Q. He, L. Cai, X. Shen, and P. Ho, “Improving TCP performance over wireless ad hoc networks with busy tone assisted scheme,” *EURASIP Journal*

- on Wireless Communications and Networking*, 2006, article ID 51610, DOI 10.1155/WCN/2006/51610.
- [20] P. Siripongwutikorn, “Throughput analysis of an IEEE 802.11b multihop ad hoc network,” in *Proc. TENCON 2006. 2006 IEEE Region 10 Conference*, 2006, pp. 1–4.
- [21] P. Ding, J. Holliday, and A. Celik, “Modeling the performance of a wireless node in multihop ad-hoc networks,” in *Wireless Networks, Communications and Mobile Computing, 2005 International Conference on*, vol. 2, 13-16 Jun. 2005, pp. 1424–1429.
- [22] D. I. L. A. Tsertou and J. S. Thompson, “A new approach for the throughput analysis of ieee 802.11 in networks with hidden terminals,” 2005, presented at the Int. Workshop Wireless Ad-hoc Netw., London, U.K.
- [23] A. Tsertou and D. I. Laurenson, “Revisiting the hidden terminal problem in a csma/ca wireless network,” *IEEE Transactions on Mobile Computing*, vol. 7, no. 7, pp. 817–831, 2008.
- [24] D. Vassis and G. Kormentzas, “Throughput analysis for ieee 802.11 ad hoc networks under the hidden terminal problem,” in *Consumer Communications and Networking Conference, 2006. CCNC 2006. 3rd IEEE*, vol. 2, jan. 2006, pp. 1273 – 1276.
- [25] T. Senthilkumar, A. Krishnan, and P. Kumar, “New approach for throughput analysis of ieee 802.11 in adhoc networks,” in *Electrical and Computer Engineering, 2008. ICECE 2008. International Conference on*, dec. 2008, pp. 466 –471.

- [26] B. Jang and M. L. Sichitiu, "Ieee 802.11 saturation throughput analysis in the presence of hidden terminals," *Networking, IEEE/ACM Transactions on*, vol. PP, no. 99, p. 1, 2011.
- [27] P. Wang and W. Zhuang, "An improved busy-tone solution for collision avoidance in wireless ad hoc networks," in *Proc. IEEE ICC, vol. 8:3802-7, 2006*.
- [28] O. Ekici and A. Yongacoglu, "Ieee 802.11a throughput performance with hidden nodes," *Communications Letters, IEEE*, vol. 12, no. 6, pp. 465–467, june 2008.
- [29] T.-C. Hou, L.-F. Tsao, and H.-C. Liu, "Analyzing the throughput of ieee 802.11 dcf scheme with hidden nodes," in *Vehicular Technology Conference, 2003. VTC 2003-Fall. 2003 IEEE 58th*, vol. 5, oct. 2003, pp. 2870 – 2874 Vol.5.
- [30] M. Ergen and P. Varaiya, "Throughput analysis and admission control for ieee 802.11a," *Mob. Netw. Appl.*, vol. 10, pp. 705–716, October 2005.
- [31] F. Cali, M. Conti, and E. Gregori, "Dynamic tuning of the ieee 802.11 protocol to achieve a theoretical throughput limit," pp. 785–799, 2000, networking, IEEE/ACM Transactions on.
- [32] T.-C. Hou, L.-F. Tsao, and H.-C. Liu, "Throughput analysis of the ieee 802.11 dcf scheme in multi-hop ad hoc networks." in *International Conference on Wireless Networks'03*, 2003, pp. 653–659.
- [33] K.-L. Hung and B. Bensaou, "Throughput analysis and rate control for ieee 802.11 wireless lan with hidden terminals," in *Proceedings of the 11th international symposium on Modeling, analysis and simulation of wireless and mobile systems*, ser. MSWiM '08. ACM, 2008, pp. 140–147.

- [34] L. B. Jiang and S. C. Liew, "Hidden-node removal and its application in cellular wifi networks," *IEEE Transactions on Vehicular Technology*, vol. 56, no. 5, pp. 2641–2654, 2007.
- [35] L. B. Jiang and S. C. Liew, "Improving throughput and fairness by reducing exposed and hidden nodes in 802.11 networks," *IEEE Transactions on Mobile Computing*, vol. 7, no. 1, pp. 34–49, 2008.
- [36] S. Khurana, A. Kahol, and A. P. Jayasumana, "Effect of hidden terminals on the performance of ieee 802.11 mac protocol," pp. 12–20, 1998, local Computer Networks, 1998. LCN '98. Proceedings., 23rd Annual Conference on.
- [37] Z. Li, S. Nandi, and A. Gupta, "Modeling the short-term unfairness of ieee 802.11 in presence of hidden terminals," in *NETWORKING 2004. Networking Technologies, Services, and Protocols; Performance of Computer and Communication Networks; Mobile and Wireless Communications*, ser. Lecture Notes in Computer Science, N. Mitrou, K. Kontovasilis, G. Rouskas, I. Iliadis, and L. Merakos, Eds. Springer Berlin / Heidelberg, 2004, vol. 3042, pp. 613–625.
- [38] Z. Li, S. Nandi, and A. K. Gupta, "Modeling the short-term unfairness of ieee 802.11 in presence of hidden terminals," *Performance Evaluation*, vol. 63, no. 4-5, pp. 441 – 462, 2006. [Online]. Available: <http://www.sciencedirect.com/science/article/pii/S0166531605000593>. Last accessed: August 2007.
- [39] P. C. Ng and S. C. Liew, "Throughput analysis of ieee802.11 multi-hop ad hoc networks," pp. 309–322, 2007, networking, IEEE/ACM Transactions on.
- [40] V. Vishnevsky and A. Lyakhov, "1 lans: Saturation throughput in the presence of noise," in *Proceedings of the Second International IFIP-TC6 Networking Conference on Networking Technologies, Services, and Protocols; Performance*

- of Computer and Communication Networks; and Mobile and Wireless Communications*, ser. NETWORKING '02. Springer-Verlag, 2002, pp. 1008–1019. [Online]. Available: <http://dl.acm.org/citation.cfm?id=647077.714762>. Last accessed: August 2007.
- [41] V. M. Vishnevskii, A. S. Gudilov, and A. I. Lyakhov, “Performance analysis of the broadband wireless network with decentralized control and hidden terminals,” *Autom. Remote Control*, vol. 69, pp. 1752–1764, October 2008. [Online]. Available: <http://dl.acm.org/citation.cfm?id=1452948.1452951>. Last accessed: August 2007.
- [42] Y. Wang and J. J. Garcia-Luna-Aceves, “Modeling of collision avoidance protocols in single-channel multihop wireless networks,” *Wirel. Netw.*, vol. 10, pp. 495–506, September 2004. [Online]. Available: <http://dx.doi.org/10.1023/B:WINE.0000036453.53208.2d>. Last accessed: August 2007.
- [43] H. Wu, F. Zhu, Q. Zhang, and Z. Niu, “Wsn02-1: Analysis of ieee 802.11 dcf with hidden terminals,” 2006, global Telecommunications Conference, 2006. GLOBECOM '06. IEEE.
- [44] L. Xie, H. Wang, G. Wei, and Z. Xie, “Performance analysis of ieee 802.11 dcf in multi-hop ad hoc networks,” pp. 227–230, 2009, networks Security, Wireless Communications and Trusted Computing, 2009. NSWCTC '09. International Conference on.
- [45] P. Karn, “Maca a new channel access method for packet radio,” in *ARRL 9th Comp. Net. Conf.*, pp. 134–40, 1990.

- [46] N. Maung, T. Noguchi, and M. Kawai, "Maximizing aggregate throughput of wireless ad hoc networks using enhanced physical carrier sensing," in *Proc. 28th ICDCS*, pp. 132–7, 2008.
- [47] T. You, C.-H. Yeh, and H. Hassanein, "CSMA/IC: a new class of collision-free mac protocols for ad hoc wireless networks," in *Proc. ISCC*, vol. 2:843–8, 2003.
- [48] Z. J. Haas and J. Deng, "Dual busy tone multiple access (dbtma) a multiple access control scheme for ad hoc networks," *IEEE Trans. Commun.*, vol. 50, no. 6, pp. 975–985, June 2002.
- [49] P. Wang, H. Jiang, and W. Zhuang, "A new mac scheme supporting voice/data traffic in wireless ad hoc networks," *IEEE Trans. on Mobile Computing*, vol. 7, no. 12, pp. 1491–1503, 2008.
- [50] Q. He, L. Cai, X. Shen, and P. Ho, "Using busy tone to improve TCP performance over wireless ad hoc networks," *EURASIP J. on Wireless Comm. and Net.*, pp. 1-1-1, 2006.
- [51] K. Yu and W. Choi, "A reliable multicast mac protocol using busy-tone for the ieee 802.11-based wireless networks," in *Information Science and Applications (ICISA), 2011 International Conference on*, april 2011, pp. 1–7.
- [52] M. Hassan, H. Vu, and T. Sakurai, "Performance analysis of the ieee 802.11 mac protocol for dsrc safety applications," *Vehicular Technology, IEEE Transactions on*, vol. PP, no. 99, p. 1, 2011.
- [53] C.-Y. Chang, L.-L. Hung, C.-Y. Lin, and M.-H. Li, "On distinguishing relative locations with busy tones for wireless sensor networks," in *Communications (ICC), 2010 IEEE International Conference on*, may 2010, pp. 1–5.

- [54] G. Feng, W. Wang, and J. Cai, “Reliable busy tone multiple access protocol for safety applications in vehicular ad hoc networks,” in *Communications (ICC), 2010 IEEE International Conference on*, may 2010, pp. 1–5.
- [55] H. Adam, E. Yanmaz, W. Elmenreich, and C. Bettstetter, “Contention-based neighborhood estimation,” in *Vehicular Technology Conference (VTC 2010-Spring), 2010 IEEE 71st*, may 2010, pp. 1–5.
- [56] H. Zhu and J. Sydor, “Throughput performance of a busy-tone protocol in cca modified, long range ieee 802.11 networks,” in *Radio and Wireless Symposium (RWS), 2010 IEEE*, jan. 2010, pp. 617–620.
- [57] S. Sayed, Y. Yang, H. Guo, and H. Hu, “Analysis of energy efficiency of a busy tone based cooperative mac protocol for multi-rate wlans,” in *Wireless Communications and Networking Conference (WCNC), 2010 IEEE*, april 2010, pp. 1–6.
- [58] H. Shan, W. Zhuang, and Z. Wang, “Distributed cooperative MAC for multi-hop wireless networks,” *IEEE Communications Magazine*, vol. 47, no. 2, pp. 126–133, 2009.
- [59] K. Liu, S. Leng, H. Fu, and L. Li, “A novel dual busy tone aided mac protocol for multi-hop wireless networks,” in *Dependable, Autonomic and Secure Computing, 2009. DASC '09. Eighth IEEE International Conference on*, dec. 2009, pp. 373–378.
- [60] H. Wang and C.-C. Tsou, “A rate adaptation scheme with loss differentiation for wlan,” in *Hybrid Intelligent Systems, 2009. HIS '09. Ninth International Conference on*, vol. 1, aug. 2009, pp. 108–112.

- [61] W. Ke and W. Qian-Ping, "A cross-layer-based mac protocol," in *Wireless Communications, Networking and Mobile Computing, 2008. WiCOM '08. 4th International Conference on*, oct. 2008, pp. 1–4.
- [62] P. Agyapong, H. Haas, A. Tyrrell, and G. Auer, "Interference tolerance signaling using tdd busy tone concept," in *Vehicular Technology Conference, 2007. VTC2007-Spring. IEEE 65th*, april 2007, pp. 2850–2854.
- [63] N. Patel, D. Kivanc-Tureli, and U. Tureli, "The effect of frequency offset on the multiple antennas receiver initiated busy tone medium access (maribtma) protocol," in *Military Communications Conference, 2006. MILCOM 2006. IEEE*, oct. 2006, pp. 1–6.
- [64] M. Chen, G. Zhu, D. Wu, and W. Yuan, "Dmabt: A novel distributed medium access protocol with busy tone," in *Vehicular Technology Conference, 2007. VTC-2007 Fall. 2007 IEEE 66th*, 30 2007-oct. 3 2007, pp. 1613–1617.
- [65] B. Ji, "Asynchronous busy-tone multiple access with acknowledgement (abtma/ack) for ad hoc wireless networks," in *Global Telecommunications Conference, 2005. GLOBECOM '05. IEEE*, vol. 6, dec. 2005, pp. 5 pp. –3647.
- [66] C. Guo, L. C. Zhong, and J. Rabaey, "Low power distributed MAC for ad hoc sensor radio networks," in *IEEE GLOBECOM'01*, vol. 5, 2001, pp. 2944–48.
- [67] O. Tickoo and B. Sikdar, "Queueing analysis and delay mitigation in IEEE 802.11 random access MAC based wireless networks," in *IEEE INFOCOM'04*, vol. 2, March 2004, pp. 1404–1413.
- [68] L. X. Cai, L. Cai, X. Shen, J. Mark, and Q. Zhang, "MAC protocol design and optimization for multi-hop ultra-wideband networks," *IEEE Trans. on Wireless Communications*, vol. 8, no. 8, pp. 4056–65, 2009.

- [69] C. S. D. W. R. Ramanathan, J. Redi and S. Polit, “Ad hoc networking with directional antennas: A complete system solution,” *IEEE J. Sel. Areas Commun.*, vol. 23, no. 3, pp. 496–506, march 2005.
- [70] R. R. Choudhury, X. Yang, N. H. Vaidya, and R. Ramanathan, “Using directional antennas for medium access control in ad hoc networks,” in *ACM MobiCom’02*, 2002, pp. 59–70.
- [71] M. B. M. Takata and T. Watanabe, “A mac protocol with directional antennas for deafness avoidance in ad hoc networks,” in *IEEE Global Telecommunications Conference (GLOBECOM), Washington, USA*, November 2007, pp. 620–625.
- [72] S. T. V. Kolar and N. B. Abu-Ghazaleh, “Avoiding head of line blocking in directional antenna,” in *IEEE International Conference on Local Computer Networks (LCN), Zurich, Switzerland*, November 2004, pp. 385–392.
- [73] O. Bazan and M. Jaseemuddin, “An opportunistic directional mac protocol for multihop wireless networks with switched beam directional antennas,” in *IEEE International Conference on Communications (ICC), Beijing, China*, 2008, pp. 2775–2779.
- [74] R. Choudhury and N. Vaidya, “Mac-layer capture: A problem in wireless mesh networks using beamforming antennas,” in *IEEE Sensor, Mesh and Ad Hoc Communications and Networks (SECON), San Diego, California*, June 2007, pp. 401–410.
- [75] N. Fahmy and T. Todd, “A selective csma protocol with cooperative nulling for ad hoc networks with smart antennas,” in *IEEE Wireless Communications and Networking Conference (WCNC), Atlanta, Georgia*, March 2004, pp. 387–392.

- [76] P. R. J. C. Mundarath and B. D. V. Veen, "Nullhoc : A mac protocol for adaptive antenna array based wireless ad hoc networks in multipath environments," in *IEEE Global Telecommunications Conference (GLOBECOM)*, vol. 5, Dallas, Texas, November 2004, pp. 2765–2769.
- [77] M. K. A. Arora and A. Muqattash, "Directional medium access protocol (dmap) with power control for wireless ad hoc networks," in *IEEE Global Telecommunications Conference (GLOBECOM)*, vol. 5, Dallas, Texas, November 2004, pp. 2797–2801.
- [78] M. Takata, M. Bandai, and T. Watanabe, "A receiver-initiated directional mac protocol for handling deafness in ad hoc networks," in *IEEE International Conference on Communications (ICC)*, vol. 9, June 2006, pp. 4089–4095.
- [79] J.-F. D. K. Fakih and G. Andrieux, "Beamforming in ad hoc networks: Mac design and performance modeling," *EURASIP Journal on Wireless Communications and Networking*, Article ID 839421, 15 pages, 2009. doi:10.1155/2009/839421.
- [80] C. C. H. Gossain and D. P. Agrawal, "MDA: an efficient directional mac scheme for wireless ad hoc networks," in *IEEE Global Telecommunications Conference (GLOBECOM)*, vol. 6, St. Louis, Missouri, November 2005, pp. 3633–3637.
- [81] K. W. Chin, "Spotmac: A pencil-beam mac for wireless mesh networks," in *IEEE International Conference on Computer Communications and Networks (ICCCN)*, Honolulu, Hawaii, August 2007, pp. 81–88.
- [82] S. H. S. Bandyopadhyay, K. Hasuike and S. Tawara, "An adaptive mac protocol for wireless ad hoc community network (wacnet) using electronically steerable passive array radiator antenna," in *IEEE Global Telecommunications*

- Conference (GLOBECOM), San Antonio, Texas, November 2001, pp. 2896–2900.*
- [83] F. M. A. Capone and L. Fratta, “Directional mac and routing schemes for power controlled wireless mesh networks with adaptive antennas,” *Elsevier Journal of Ad Hoc Networks*, vol. 6, no. 6, pp. 936–952, 2008.
- [84] R. Choudhury and N. Vaidya, “Deafness: A MAC problem in ad hoc networks when using directional antennas,” in *IEEE ICNP’07*, 2004, pp. 283–292.
- [85] R. R. Choudhury, X. Yang and N. H. Vaidya, “On designing mac protocols for wireless networks using directional antennas,” *IEEE Trans. Mobile Comput.*, vol. 5, pp. 477–491, May 2006.
- [86] S. Kulkarni and C. Rosenberg, “DBSMA: A MAC protocol for multi-hop ad-hoc networks with directional antennas,” in *IEEE PIMRC’05*, vol. 2, 11-14 Sept. 2005, pp. 1371–1377.
- [87] Z. Huang, C. chung Shen, C. Srisathapornphat, and C. Jaikaeo, “A busy-tone based directional MAC protocol for ad hoc networks,” in *IEEE Milcom’02*, 2002, pp. 1233–38.
- [88] Q. He, L. Cai, X. Shen, and P. H. Ho, “Improving TCP performance over wireless ad hoc networks with busy tone assisted scheme,” *EURASIP J. Wireless Communications and Networking*, vol. 2006, no. 51610, pp. 1–11, 2006.
- [89] H. Singh and S. Singh, “Smart-802.11b mac protocol for use with smart antennas,” in *IEEE International Conference on Communications (ICC), Paris, France, 2004*, pp. 3684–3688.
- [90] M. R. H. V. A. RamMohan, H. Sethu and K. R. Dandekar, “A new protocol to mitigate the unheard rts/cts problem in networks with switched beam

- antennas,” in *IEEE International Symposium on Wireless Pervasive Computing (ISWPC)*, San Juan, Puerto Rico, February 2007, pp. 129–134.
- [91] W. S. Y. Li, M. Li and M.-Y. Wu, “Fft-dmac: A tone based mac protocol with directional antennas,” in *IEEE Global Telecommunications Conference (GLOBECOM)*, Washington, USA, November 2007, pp. 3661–3665.
- [92] K. W. N. H. N. Dai and M. Y. Wu, “A busy-tone based mac scheme for wireless ad hoc networks using directional antennas,” in *IEEE Global Telecommunications Conference (GLOBECOM)*, Washington, USA, November 2007, pp. 4969–4973.
- [93] M. B. Y. Takatsuka, M. Takata and T. Watanabe, “A mac protocol for directional hidden terminal and minor lobe problems,” in *IEEE Wireless Telecommunications Symposium (WTS)*, Pomona, California, 2008, pp. 210–219.
- [94] Y. B. Ko, V. Shankarkumar, and N. Vaidya, “Medium access control protocols using directional antennas in ad hoc networks,” in *IEEE INFOCOM’00*, vol. 1, 26-30 March 2000, pp. 13–21.
- [95] A. Nasipuri, S. Ye, J. You, and R. Hiromoto, “A MAC protocol for mobile ad hoc networks using directional antennas,” in *IEEE WCNC’00*, vol. 3, 23-28 Sept. 2000, pp. 1214–1219.
- [96] M. Takai, J. Martin, A. Ren, and R. Bagrodia, “Directional virtual carrier sensing for directional antennas in mobile ad hoc networks,” in *ACM Mobihoc’02*, 2002, pp. 183–193.

- [97] E. Shihab, L. Cai, and J. Pan, "A distributed, asynchronous directional-to-directional MAC protocol for wireless ad hoc networks," *IEEE Trans. on Veh. Tech.*, vol. 58, no. 9, pp. 5124–34, Nov. 2009.
- [98] T. Korakis, G. Jakllari, and L. Tassiulas, "A MAC protocol for full exploitation of directional antennas in ad-hoc wireless networks," in *ACM MobiHoc'03*, 2003, pp. 98–107.
- [99] J. Deng and Z. Haas, "Dual busy tone multiple access (DBTMA): a new medium access control for packet radio networks," in *Proc. ICUPC, vol. 2:973–7, 1998*.
- [100] A. Goldsmith, *WIRELESS COMMUNICATIONS*. Cambridge University Press, 2005.
- [101] S. Haykin and M. Moher, *Introduction to Analog & Digital Communications*. Wiley, 2007.
- [102] C. Ware, T. Wysocki, and J. Chicharo, "Hidden terminal jamming problems in iee 802.11 mobile ad hoc networks," pp. 261–265, iCC 2001, IEEE International Conference on.
- [103] J. Deng, Y. Han, P.-N. Chen, and P. Varshney, "Optimal transmission range for wireless ad hoc networks based on energy efficiency," *Communications, IEEE Transactions on*, vol. 55, no. 9, pp. 1772–1782, Sept. 2007.
- [104] A. Abdullah, F. Gebali, and L. Cai, "Modeling the throughput and delay in wireless multihop ad-hoc networks," in *IEEE GLOBECOM, 2009, Honolulu, Hawaii*.
- [105] A. Abdullah, L. Cai, and F. Gebali, "Enhanced busytone-assisted MAC protocol for wireless ad hoc networks," in *IEEE 72nd VTC 2010-Fall, Ottawa, Canada, 2010*.

- [106] W. Stutzman and G. Thiele, *Antenna Theory and Design*. John Wiley, 1998.
- [107] IEEE, “Iso/iec standard for information technology - telecommunications and information exchange between systems - local and metropolitan area networks - specific requirements part 11: Wireless lan medium access control (mac) and physical layer (phy) specifications,” pp. 1–721, 2005.
- [108] C. Chou and D. Peled, “Formal verification of partial order reduction technique for model checking,” *Automated Reasoning*, vol. 23, no. 3, pp. 265–298, Nov. 1999.

# Appendix A

## List of Publications

### A.1 Published Papers

1. Cheng, M. X., Gong, X., Cai, L., and Abdullah, A., “*Transmission Scheduling for CBR Traffic in Multihop Wireless Networks*”. In Proceedings of the Third international Conference on Wireless Algorithms, Systems, and Applications (Dallas, Texas, October 26 - 28, 2008).
2. Abdullah, A., Gebali, F. and Cai, L., “*Modeling the Throughput and Delay in Wireless Multihop Ad-Hoc Networks*”. IEEE Globecom 2009 (Honolulu, Hawaii, November 30 - December 4, 2009).
3. Abdullah, A., Cai, L. and Gebali, F., “*Enhanced Busy-Tone-Assisted MAC Protocol for Wireless Ad Hoc Networks*”. IEEE 72nd Vehicular Technology Conference: VTC2010-Fall 69 September 2010, Ottawa, Canada.

### A.2 Papers Under Review

1. Abdullah, A., Gebali, F. and Cai, L., “*DSDMAC: Dual Sensing Directional MAC Protocol for Ad Hoc Networks with Directional Antennas*”.

2. Abdullah, A., Gebali, F. and Cai, L., "*Link Throughput and Delay Analysis of Random Access Multihop Wireless Networks with Hidden Terminals*".

## Appendix B

### Implementing Random Node Distribution

The following C functions explain the random node distribution used in Fig. 4.3 and Fig. 5.10.

```
bool in_circle(int center_x, int center_y, int radius, int x, int y)
{
    /*return whether a node is within a circle */
    unsigned square_dist;

    square_dist = pow((center_x - x),2) + pow((center_y - y),2);
    if (square_dist <= pow(radius,2))
        return 1;
    else
        return 0;
}
```

```
void circular_topo(int txrange, int maxn) {
    /* Generate network topology */
    int rx, ry, i=1;

    do
    {
        srand(time(0));
        rx=rand()%(txrange*2) +1;
        ry=rand()%(txrange*2) +1;
        if (in_circle(txrange,txrange,txrange,rx,ry))
        {
            node[i].id=i;
        }
    }
}
```

```
        node[i].x=rx;
        node[i].y=ry;
        i++;
    }
} while (i<=maxn);
return;
}
```