

**Characterization of the PdpA protein and its role in the  
intracellular lifestyle of *Francisella novicida***

by

Crystal Lynn Schmerk  
B.Sc., Lakehead University, 2004

A Dissertation Submitted in Partial Fulfillment of the  
Requirements for the Degree of

DOCTOR OF PHILOSOPHY

in the Department of Biochemistry and Microbiology

© Crystal Lynn Schmerk, 2010  
University of Victoria

All Rights Reserved. This dissertation may not be reproduced in whole or in part,  
by photocopying or other means, without the permission of the author.

## Supervisory Committee

### Characterization of the PdpA protein and its role in the intracellular lifestyle of *Francisella novicida*

by

Crystal Lynn Schmerk  
B.Sc., Lakehead University, 2004

#### Supervisory Committee:

Dr. Francis E. Nano, (Department of Biochemistry and Microbiology)  
Supervisor

Dr. Caren C. Helbing, (Department of Biochemistry and Microbiology)  
Departmental Member

Dr. Perry L. Howard, (Department of Biochemistry and Microbiology)  
Departmental Member

Dr. William E. Hintz, (Department of Biology)  
Outside Member

## Abstract

### Supervisory Committee:

Dr. Francis E. Nano, (Department of Biochemistry and Microbiology)

Supervisor

Dr. Caren C. Helbing, (Department of Biochemistry and Microbiology)

Departmental Member

Dr. Perry L. Howard, (Department of Biochemistry and Microbiology)

Departmental Member

Dr. William E. Hintz, (Department of Biology)

Outside Member

*Francisella tularensis* is a highly virulent, intracellular pathogen that causes the disease tularaemia. *Francisella* species contain a cluster of genes referred to as the *Francisella* pathogenicity island (FPI). Several genes contained in the FPI encode proteins needed for the intracellular growth and virulence of *Francisella tularensis*. Pathogenicity determinant protein A (PdpA), encoded by the *pdpA* gene, is located within the FPI and has been associated with the virulence of *Francisella* species.

The experiments outlined in this dissertation examine the properties of PdpA protein expression and localization as well as the phenotypes of non-polar *F. novicida* *pdpA* mutants. Monoclonal antibody detection of PdpA showed that it is a soluble protein that is upregulated in iron-limiting conditions and undetectable in an *mglA* or *mglB* mutant background. Deletion of *pdpA* resulted in a strain that was highly attenuated for virulence in chicken embryos and mice.

The  $\Delta$ *pdpA* strain was capable of a small amount of intracellular replication but, unlike wild-type *F. novicida*, remained associated with the lysosomal marker LAMP-1, suggesting that PdpA is necessary for progression from the early phagosome phase of

infection. Infection of macrophages with the  $\Delta pdpA$  mutant generated a host-cell mRNA profile distinct from that generated by infection with wild type *F. novicida*. The transcriptional response of the host macrophage indicates that PdpA functions directly or indirectly to suppress macrophage ability to signal via growth factors, cytokines and adhesion ligands.

Experiments were designed to mutagenize a putative F-box domain within the amino terminus of PdpA. Deletion of amino acids 112-227 created a strain which was impaired in intracellular replication and exhibited severely reduced virulence. However, alanine mutagenesis of key conserved leucine residues required for the interaction of F-box domains with host proteins had no observed effect on bacterial growth in macrophages and did not affect virulence in chicken embryos or mice.

Mono and polyubiquitinated proteins associated with both the wild type *F. novicida* and  $\Delta pdpA$  bacterial strains early during the infection of J774A.1 macrophages. After 1 hour of infection the wild type strain developed a more intimate association with mono and polyubiquitinated proteins whereas the  $\Delta pdpA$  strain did not. Inhibition of the host cell proteasome during infection did not affect the intracellular growth of wild type *F. novicida*.

PdpA research concludes by examining the secretion patterns of *F. novicida*. PdpA was not detected as a surface exposed protein using biotinylation whereas IglA, IglB and IglC were found to be surface exposed in both wild type and  $\Delta pdpA$  backgrounds. These observations suggest that PdpA is not involved in the assembly or function of the *Francisella* secretion system. FLAG tagged PdpA protein could not be detected in the TCA precipitated supernatant of broth grown cultures or in the

immunoprecipitated cytosol of infected macrophages suggesting that PdpA is not a secreted protein.

## Table of Contents

Supervisory Committee.....	ii
Abstract.....	iii
Table of Contents.....	vi
List of Tables.....	ix
List of Figures.....	x
List of Abbreviations.....	xii
Acknowledgements.....	xvi
Dedication.....	xvii
Chapter 1: Introduction.....	1
1.1 <i>Francisella tularensis</i> .....	1
1.1.1 History.....	1
1.1.2 <i>Francisella tularensis</i> subspecies.....	2
1.1.3 Disease and treatment.....	4
1.1.4 Intracellular lifestyle.....	6
1.1.5 Host response to infection.....	12
1.1.5.1 Lipopolysaccharide.....	12
1.1.5.2 Immune response.....	13
1.1.6 Pathogenicity islands.....	16
1.1.7 The <i>Francisella</i> pathogenicity island.....	20
1.1.8 Regulation of the FPI.....	24
1.1.9 The <i>Francisella</i> secretion system.....	25
1.2 Bacterial manipulation of phagosome maturation.....	29
1.2.1 Phagosome maturation.....	29
1.2.2 Arresting phagosome maturation.....	33
1.2.3 Escape from the phagosome.....	37
1.2.4 Creation of unique membrane structures.....	39
1.3 Bacterial pathogens and ubiquitination.....	44
1.3.1 The many roles of ubiquitin.....	44
1.3.2 Bacterial interference With ubiquitination involved in host immune response.....	48
1.3.3 Bacterial effector proteins modified by ubiquitination.....	49
1.3.4 Bacterial mimicry of host proteins involved in ubiquitination.....	52
1.4 Research objectives and dissertation outline.....	55
Chapter 2: Characterization of the pathogenicity island protein PdpA and its role in the virulence of <i>Francisella novicida</i> .....	57
2.1 Introduction.....	57
2.2 Materials and Methods.....	60
2.2.1 Bacterial strains and growth conditions.....	60
2.2.2 Mutagenesis and complementation.....	60
2.2.3 SDS-PAGE and immunoblotting.....	61

2.2.4 Iron-limitation studies.....	62
2.2.5 Subcellular fractionation of <i>F. novicida</i> .....	62
2.2.6 Chicken embryo infections.....	63
2.2.7 Mouse infections.....	64
2.2.8 Graphing and statistics.....	64
2.3 Results.....	65
2.3.1 Detection of PdpA with monoclonal antibody.....	65
2.3.2 Solubility of PdpA.....	69
2.3.3 PdpA levels affected by <i>mglAB</i> background and iron concentration.....	70
2.3.4 Virulence properties of the <i>pdpA</i> mutant.....	71
2.4 Discussion.....	73
Chapter 3: A <i>Francisella novicida pdpA</i> mutant exhibits limited intracellular replication and remains associated with the lysosomal marker LAMP-1.....	77
3.1 Introduction.....	77
3.2 Materials and Methods.....	79
3.2.1 Bacterial strains and growth conditions.....	79
3.2.2 Intracellular growth assays.....	79
3.2.3 Real-time PCR assays.....	80
3.2.4 Immunofluorescence and LAMP-1 association.....	80
3.2.5 Graphing and statistics.....	81
3.3 Results.....	82
3.3.1 Intracellular growth of <i>pdpA</i> mutants.....	82
3.3.2 LAMP-1 association of the <i>pdpA</i> mutant.....	84
3.3.3 Effect of the deletion of <i>pdpA</i> on host-cell mRNA responses.....	88
3.4 Discussion.....	92
Chapter 4: Efforts in determining the function of PdpA.....	95
4.1 Introduction.....	95
4.2 Materials and Methods.....	97
4.2.1 Bacterial strains and growth conditions.....	97
4.2.2 Mutagenesis and complementation.....	97
4.2.3 Expression of FLAG-epitope tagged FPI proteins in <i>F. novicida</i> .....	98
4.2.4 Intracellular growth assays.....	98
4.2.5 Chicken embryo infections.....	98
4.2.6 NIH 3T3 fibroblast immunofluorescence.....	99
4.2.7 Ubiquitin localization immunofluorescence.....	99
4.2.8 Western immunoblot analysis.....	100
4.2.9 Biotinylation of <i>Francisella</i> outer membrane proteins.....	100
4.2.10 Immunoprecipitation of secreted <i>Francisella</i> protein from broth grown culture.....	101
4.2.11 Immunoprecipitation of secreted <i>Francisella</i> protein from infected macrophages.....	101
4.2.12 Graphing and statistics.....	102

4.3 Results.....	104
4.3.1 Intracellular growth and virulence of a <i>pdpA</i> Δ112-227 mutant....	104
4.3.2 Alanine mutagenesis of the predicted PdpA F-box domain.....	111
4.3.3 Ubiquitin association with Δ <i>pdpA</i> containing phagosomes.....	114
4.3.4 Biotinylation of surface exposed <i>Francisella</i> proteins.....	116
4.3.5 Precipitation of secreted <i>Francisella</i> proteins.....	118
4.4 Discussion.....	121
Chapter 5: Conclusions and future studies.....	128
Chapter 6: Bibliography.....	132

## List of Tables

<b>Table 1.</b> Bacterial strains and plasmids used in the deletion of <i>pdpA</i> , the creation of its complement and the characterization of the PdpA protein.....	64
<b>Table 2.</b> Bacterial strains used to study the intracellular growth phenotype of the <i>pdpA</i> mutant and host cell signalling pathways altered by infection with <i>F. novicida</i> .....	82
<b>Table 3.</b> Changes in mRNA levels of J744 macrophage-like cells following infection with <i>F. novicida</i> strains.....	89
<b>Table 4.</b> Bacterial strains and plasmids used in creating targeted deletions within <i>pdpA</i> and in studying PdpA function and <i>Francisella</i> secretion.....	102

## List of Figures

<b>Figure 1.</b> Phagocytic uptake of <i>Francisella</i> .....	7
<b>Figure 2.</b> Maturation of the <i>Francisella</i> containing phagosome.....	10
<b>Figure 3.</b> Horizontal gene transfer resulting in the creation of pathogenicity islands....	18
<b>Figure 4.</b> The <i>Francisella</i> Pathogenicity Island.....	21
<b>Figure 5.</b> Amino acid conservation of PdpA.....	23
<b>Figure 6.</b> The <i>Francisella</i> secretion system.....	28
<b>Figure 7.</b> Alteration of phagosome maturation by bacterial pathogens.....	43
<b>Figure 8.</b> The eukaryotic ubiquitin pathway.....	47
<b>Figure 9.</b> Deletion of <i>pdpA</i> .....	59
<b>Figure 10.</b> Detection and subcellular localization of PdpA in <i>Francisella</i> .....	68
<b>Figure 11.</b> Regulation of PdpA expression by iron and transcriptional regulators.....	71
<b>Figure 12.</b> Attenuation of the <i>pdpA</i> mutant in chicken embryos.....	73
<b>Figure 13.</b> Intracellular growth of <i>pdpA</i> mutants.....	84
<b>Figure 14.</b> The <i>pdpA</i> mutant replicates in macrophages but remains LAMP-1 associated.....	86
<b>Figure 15.</b> The <i>pdpA</i> mutant remains LAMP-1 associated late in infection.....	87
<b>Figure 16.</b> Association of <i>F. novicida</i> mutants with LAMP-1.....	88
<b>Figure 17.</b> PdpA F-box alignment and mutagenesis.....	105
<b>Figure 18.</b> Intracellular growth of <i>pdpA</i> $\Delta$ 112-227 mutant in macrophages and NIH3T3 fibroblasts.....	107
<b>Figure 19.</b> Intracellular growth and LAMP-1 association of <i>pdpA</i> $\Delta$ 112-227 mutant NIH3T3 fibroblasts.....	109
<b>Figure 20.</b> Attenuation of the <i>pdpA</i> $\Delta$ 112-227 mutant in chicken embryos.....	110

<b>Figure 21.</b> Intracellular growth of <i>pdpA</i> alanine mutants in macrophages.....	112
<b>Figure 22.</b> Attenuation of the <i>pdpA</i> alanine mutants in chicken embryos.....	113
<b>Figure 23.</b> The association of the $\Delta$ <i>pdpA</i> mutant with mono and polyubiquitinated proteins.....	115
<b>Figure 24.</b> Biotinylation of surface exposed proteins in a wild type and $\Delta$ <i>pdpA</i> background.....	117
<b>Figure 25.</b> Detection of <i>Francisella</i> proteins secreted into the supernatant of broth grown culture.....	119
<b>Figure 26.</b> PdpA-FLAG is not secreted into the macrophage cytosol during infection.....	120

## List of Abbreviations

aa	amino acid
amp	ampicillin
ARF-1	ADP-ribosylation factor 1
BKO	B cell knockout
bp	base pair
BMDM	bone marrow-derived macrophage
Cdc42	cell division control protein 42
CFU	colony forming unit
CR3	complement receptor 3
cDMEM	complete Dulbecco's Modified Eagle Medium
Desferal	deferoxamine mesylate salt
DUB	deubiquitinating enzyme
EEA-1	early endosomal antigen-1
ER	endoplasmic reticulum
ESCRT	endosomal-sorting complex
FBS	fetal bovine serum
FPI	<i>Francisella</i> pathogenicity island
em	erythromycin
em <sup>R</sup>	erythromycin resistance
GC	guanine-cytosine
ppGpp	guanosine-tetraphosphate
HECT	homologous-to-the-E6-AP-carboxyl-terminus

Hrs	hepatocyte growth factor-regulated tyrosine kinase substrate
HR	hypersensitive response
IKK $\beta$	IkappaB kinase beta
IRAK	IL-1 receptor-associated kinase
I $\kappa$ B	inhibitor of NF $\kappa$ B
IFN- $\gamma$	interferon-gamma
IL	interleukin
<i>igl</i>	intramacrophage growth locus
kb	kilobase pairs
km	kanamycin
km <sup>R</sup>	kanamycin resistance
LAM	lipoarabinomannan
LAMP	lysosomal-associated membrane protein
LB	Luria-Bertani
LC3	microtubule-associated protein1 light chain 3
LCV	<i>Legionella</i> containing vacuole
LLO	listeriolysin O
LPS	lipopolysaccharide
LVS	live vaccine strain
MglA	macrophage growth locus A
MHC	major histocompatibility complex
M6PR	mannose-6-phosphate receptor
MAPK	mitogen-activated protein kinase

m.o.i	multiplicity of infection
MyD88	myeloid differentiation primary response gene 88 protein
NSF	N-ethylmaleimide-sensitive factor
NEMO	NF $\kappa$ B essential modulator
NO	nitric oxide
NF $\kappa$ B	nuclear factor kappa B
ORF	open reading frame
<i>pdp</i>	pathogenicity determinant protein
PAI	pathogenicity island
PC-PLC	phosphatidylcholine-specific phospholipase-C
[PI(3)P]	phosphatidylinositol-3-phosphate
[PI(4)P]	phosphatidylinositol-4-phosphate
PI3K	phosphoinositide 3-kinase
PLC	phospholipase C
PMN	polymorphonuclear neutrophil
PTM	posttranslational modification
qRT-PCR	quantitative real-time PCR
RILP	Rab7-interacting lysosomal protein
Rac-1	Ras-related C3 botulinum toxin substrate 1
RING	really-interesting-new-gene
RNAP	RNA polymerase
SCV	<i>Salmonella</i> containing vacuole
Sif	<i>Salmonella</i> induced filament

SPI	<i>Salmonella</i> pathogenicity island
SCF complex	Skp, Cullin, F-box containing complex
Skp1	S-phase kinase-associated protein 1
Sarkosyl	sodium lauroyl sarcosinate
SNARE	soluble NSF attachment protein receptor
SNX1	sorting nexin protein 1
SspA	stringent starvation protein A
TRAF-6	TNF receptor associated factor-6
TLR	Toll-like receptor
T-DNA	transfer DNA
tRNA	transfer RNA
TSAC	trypticase soy agar
TSBC	trypticase soy broth
TNF- $\alpha$	tumor necrosis factor-alpha
T2SS	type II secretion systems
T3SS	type III secretion system
T4SS	type IV secretion system
T6SS	type VI secretion system
ub	ubiquitin
VIP1	VirE2-interacting protein 1
WT	wild type
Yop	<i>Yersinia</i> outer protein

## Acknowledgements

It is amazing how fast my time researching at the University of Victoria seems to have passed. The insight and support of Dr. Nano and my lab mates has been wonderful. They were always there to help with my research and share their ideas, even when I thought my experiments were doomed to constant failure. I want to especially thank Eli, Olle, and Barry whose friendship over the years has meant so much to me. I also wish to give a special thanks to Fran, you are a brilliant and wonderful supervisor (but remember, sometimes you just have to throw ancient equipment away).

To my wonderful parents, especially my mom, thank you for always letting me choose my own career path and supporting me even when my decisions took me so far away from you; I love you so much. I am also so happy that my brother decided to join me here for my last years in Victoria (well not so much joined me as asked me to come pick him up...from Lake Louise). I love you Chris and it will be hard living so far away from you.

I am so thankful for the constant love and encouragement I receive from Andy, my future husband. His selfless support of my future in science amazes me more and more everyday. I know this process has been difficult for him at times and I know the countless hours of COD he had to play on his Xbox while I wrote my thesis and spent long nights at the lab must have been torture. I love you forever babe.

## **Dedication**

I want to dedicate this dissertation to my loving grandparents Glen and Marlene. It breaks my heart that both of you were taken from me so early and I miss you every day. I know how much my education meant to you and how proud you were of everything I had set out to accomplish. I can only hope you're still with me now and you know how much you will always mean to me.

## Chapter 1: Introduction

There are a wide variety of pathogens which humans and animals must defend themselves against in the environment. These pathogens have adapted a variety of strategies to not only survive but thrive within the host environment. A clever example of this adaptation is the intracellular pathogen. Bacteria such as *Shigella flexneri*, *Salmonella enterica*, and *Escherichia coli* have evolved mechanisms to actively invade a range of target cells and alter the host cell environment to allow for replication and spread to new host cells (6, 156, 169, 247, 346, 355, 411). Other bacteria such as *Legionella pneumophila*, *Mycobacterium* sp., and *Francisella tularensis* gain entry via the phagocytic action of target host immune cells (8, 83, 117, 324, 326, 343, 357, 375, 386, 389). These types of intracellular pathogens require a variety of mechanisms which they must use to either alter the maturation of the phagosome or survive within its harsh environment, all while attempting to subvert the host cell's immune response. Determining the mechanisms in which intracellular bacteria achieve these actions is exceedingly difficult and as such much is not yet understood.

### 1.1 *Francisella tularensis*

#### 1.1.1 History

*Francisella tularensis* is a gram negative, facultative, intracellular bacterium and the causative agent of the zoonotic disease tularemia. The bacterium was originally isolated in Tulare County, California in 1911 where there was an endemic rodent infection (235). Research conducted by Edward Francis led to the conclusion that *F.*

*tularensis* was the common cause of a variety of human illnesses including rabbit fever, tick fever and deer fly fever (134). The diseases were then recognized as tularemia with the first official case occurring in Ohio in 1914 (403).

There are many regions endemic to *Francisella* scattered throughout the Northern hemisphere (275, 365). Outbreaks of tularemia have occurred throughout Sweden, Japan, the former USSR and Martha's Vineyard during this and the last century (118, 125, 304, 369). Tularemia has been described as a war-related pathogen due to its high incidence in relation to regions during war (143, 191, 344). This relationship is likely due to poor sanitary conditions and increased contact with infected rodent populations.

Beginning in the 1940's Japan, the United States and the USSR focused efforts on research and testing of weapons containing *F. tularensis* because of its high infectivity, disease severity and ease of aerosolization (110, 281). Rumoured use of weaponized *Francisella*, particularly during World War II, remains unsubstantiated (9, 143). The recent research shift in battling bioterrorism threats has resulted in a significant increase in understanding the virulence mechanisms of *F. tularensis* as well as in the development of tools essential for further study of the bacterium and its intracellular lifestyle.

### **1.1.2 *F. tularensis* subspecies**

There are four subspecies of *F. tularensis* including subsp. *tularensis*, *holarctica*, *mediasiatica*, and *novicida* (129). Subspecies *tularensis* and *holarctica* are responsible for the majority of human illness, however *F.t. novicida* causes severe illness in mice which is similar to human tularemia and is often used a research surrogate for *F.t. tularensis* (122). There is some debate among researchers as to whether *F.t. novicida*

should be considered a separate species of *Francisella*. DNA hybridization studies and 16S ribosomal RNA comparisons strongly support the classification of a *F.t. novicida* subspecies (21, 129, 178). *F.t. novicida* rarely causes disease in humans; individuals that do acquire an infection are usually immunocompromised (81, 122, 178).

*Francisella* infects a wide variety of hosts, including mammals, insects, arthropods and protozoa. *F.t. tularensis* is primarily found in North America and is most often isolated from ticks, deerflies, lagomorphs and rodents (281, 326). It is the most virulent of the four subspecies; contact with as few as 10 c.f.u. can cause disease (328, 329). *F.t. holarctica* causes the majority of human illness and is found throughout the Northern Hemisphere (281). This subspecies is less virulent than *F.t. tularensis* and causes milder forms of tularemia (272, 274). It can commonly be found in hares, semi-aquatic rodents and mosquitoes and seems to have a strong association with water (155, 326). This may be due to the fact that protozoa can act as *Francisella* reservoirs or be the result of association with mosquito breeding grounds (1, 324).

There is an attenuated live vaccine strain (LVS) derived from *F.t. holarctica* which is commonly used in the study of *Francisella*. This strain was created via multiple passages on peptone cysteine plates followed by repeated inoculation of mice (116). This strain has yet to be licensed as a vaccine against *F. tularensis* infection due to a lack of knowledge concerning the source of its attenuation, phenotype variation in vaccine lots, and residual virulence issues (280, 320). However, some of these issues have recently been resolved and may permit the licensing of LVS for human vaccination (280, 287, 310, 318).

### 1.1.3 Disease and treatment

The symptoms of tularemia are flu-like, including fever, chills, headache, and nausea. These non-specific symptoms can often cause misdiagnosis with other forms of febrile illness (363). The disease can be acquired through multiple routes of infection which result in varying disease manifestations. The presentation of disease is also greatly influenced by the dose a person is exposed to and the strain to which they are exposed (122, 344, 363). The most common disease manifestation is referred to as ulceroglandular tularemia. This form of tularemia results from direct contact of the bacterium with an open wound or mucous membrane; or via vector-borne transmission, commonly by ticks and mosquitoes (270, 364). There is usually an ulcer at the site of infection which can persist for several months but often goes unnoticed. The bacteria disseminate via the lymphatic system and regional lymph nodes become quite enlarged, resembling the classic bubos of bubonic plague. The bacteria then travel to tissues throughout the body including the spleen, liver and lungs. This form of the disease is rarely fatal, even without proper treatment the mortality rate is 5- 6% when infected with *F.t. tularensis* and 0.5% when infected with *F.t. holarctica* (122, 273).

Typhoidal tularemia, caused by *F.t. tularensis*, represents roughly 10% of tularemia cases and indicates severe disease without an obvious route of infection. Typhoidal tularemia does not present an ulcer or swelling of the lymph nodes but instead takes the form of a deadly septicaemia which if left untreated has a mortality rate of 30-60%. The most likely transmission route of these infections is via the respiratory route (363).

The most severe form of the disease, respiratory tularemia, results from the inhalation of contaminated aerosols. This is commonly acquired by farmers and landscape workers and is how one would acquire tularemia as a consequence of biological warfare. Inhalation of *F.t. tularensis* results in high fever, chills and nausea which is sometimes accompanied by delirium and pulse-temperature dissociation (102, 362, 363). Symptoms associated with pneumonia may present themselves; however, these symptoms can also result as a complication of any form of tularemia (363). The inhalation of *F.t. holarctica* results in a much less fulminant disease with pneumonic symptoms rarely occurring (344, 362).

One of the biggest problems in treating tularemia is the rapid progression of the disease. Treatment must be administered quickly, even before diagnosis has been confirmed, in order to prevent the development of severe illness. *F. tularensis* responds well to treatment with bacteriocidal aminoglycosides (26, 188, 331). During the peak of tularemia outbreaks in the 1940's the treatment of choice was streptomycin. Its introduction reduced the mortality rate of tularemia to 3% (124). Toxicity and hypersensitivity issues associated with streptomycin have rendered the drug virtually obsolete in treatment, however it is the most effective antibiotic for the treatment of tularemia related meningitis (363). In severe cases of tularemia, gentamicin is now the administered drug of choice (124, 172, 363). Tetracyclines such as doxycycline are quite effective against *Francisella* species and have lower toxicity than aminoglycosides; however their bacteriostatic effects risk disease relapse (124, 330, 363). Doxycycline is currently used for prophylactic treatment of tularemia. Since *F. tularensis* is not a part of normal human microflora and is not spread by person to person contact it seems unlikely

that it is a risk for developing antibiotic resistance (363). Though, this does not account for the genetic engineering of antibiotic resistant strains for use in bioterrorism.

#### **1.1.4 Intracellular lifestyle**

*F. tularensis* has the ability to enter and replicate within a variety of cell types from many different species, including insect cells (302, 322, 396). The bacterium has been found to infect non-phagocytic cells such as alveolar epithelial cells (166) and hepatocytes (96) as well as phagocytic cells such as neutrophils (234) and dendritic cells (96). However, it is believed that macrophages serve as *Francisella*'s primary replicative niche.

Bacterial pathogen uptake classically fits into one of three categories: conventional phagocytosis, coiling phagocytosis, or ruffling macropinocytosis (83). The uptake of *Francisella* appears to occur via a unique process which has been termed looping phagocytosis (see Figure 1) (85). In this process the bacterium is surrounded by asymmetric pseudopod loops which do not maintain close contact with the bacterial surface. Experiments performed by Clemens *et al.* demonstrate that looping phagocytosis is triggered by preformed surface carbohydrate molecules, likely lipopolysaccharide (LPS) or capsular material (85).

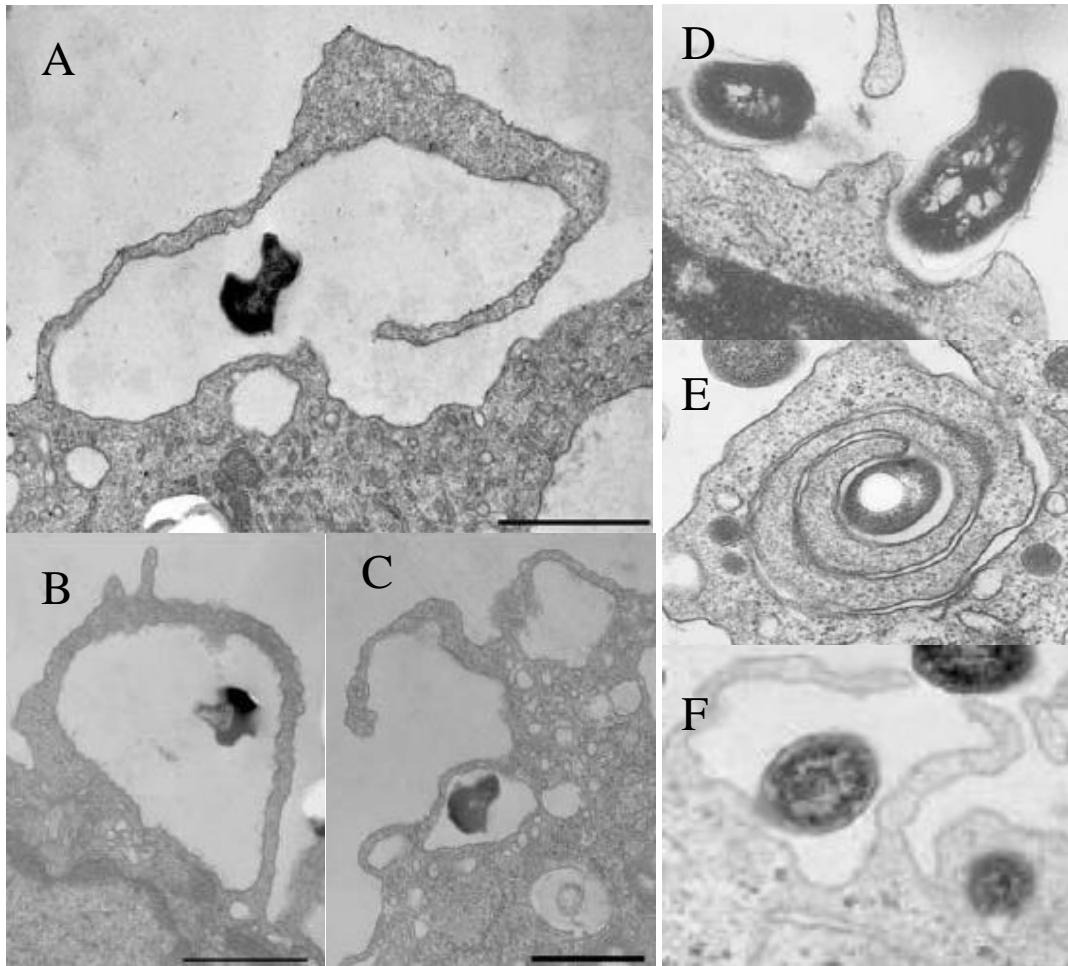

**Figure 1. Phagocytic uptake of *Francisella*.** Panels A-C show the progressive looping phagocytosis of *F.t. tularensis* by human monocyte-derived macrophages. Size bars indicate 1 $\mu$ m. The conventional phagocytosis of *M. tuberculosis* (D), coiling phagocytosis of *L. pneumophila* (E), and macropinocytosis of *S. flexneri* (F) are shown in comparison. Adapted from Clemens, D. L., and M. A. Horwitz 2007.

There are a variety of receptors on the surface of macrophages which recognize particular pathogen-associated molecular patterns; consequent binding of these ligands stimulates the uptake of foreign particles, including bacterial pathogens. In some cases the recognized ligands are host-derived opsonins, such as complement, that coat the surface of the pathogen (340). The complement receptor pathway, particularly

complement receptor 3 (CR3) and C3 complement, is vital in the uptake of *F. tularensis*. Infection of human macrophages using heat inactivated or C3-deficient serum results in negligible uptake of *Francisella* (83, 85). The exploitation of this receptor pathway is common among pathogens as this form of entry prevents the oxidative burst. There also appears to be some role in uptake involving the mannose and scavenger receptors (293, 337). These receptors recognize patterns found directly on the surface of bacteria such as those found on LPS and lipoproteins (340). Alone, these receptors seem to play minor roles and likely function to enhance uptake via the CR3 mediated process.

Once the bacterium is taken up via the spacious loops of phagocytosis it resides within a large vacuole which shrinks dramatically as it moves away from the surface of the macrophage (85). The phagosome quickly acquires markers whose distinct patterns identify sequential interaction with compartments of the endosomal-lysosomal pathway (see Figure 2). Early endosomal markers EEA-1 (early endosomal antigen-1) and Rab5 localize with the phagosomal membrane approximately 15 minutes after bacterial uptake (87, 327). The kinetics of acquisition and loss of these markers is similar for vacuoles containing live or dead *F. tularensis*, implying that the bacterium does not actively alter phagosome maturation at the early endosomal stage (87). There are marked differences in the amounts of late endosomal/lysosomal markers acquired by phagosomes containing live *Francisella*. These include lowered levels of CD63, Rab7, lysosomal-associated membrane protein 1 and 2 (LAMP-1 and LAMP-2) and no detectable levels of cathepsin D or fluorescent dextran (87, 327). There is some debate as to whether the phagosome acquires the lysosomal vATPase pump and becomes acidified (76, 86, 323). These discrepancies are likely due to differences in experimental procedures and timing. Thus,

*Francisella* is either able to prevent phagosomal-lysosomal fusion or actively triggers escape from the phagosome quickly following acidification via the vATPase proton pump, but before uniting with the lysosome. Uptake of heat-killed *F. tularensis* results in fusion of the phagosome with the lysosome and subsequent degradation of the bacterium (87).

*Francisella* is able to actively break down the phagosomal membrane and escape into the host cell cytosol approximately 1-4 hours post-infection. This timing varies based on the bacterial strain being used and the cell type being infected (71, 87, 150, 325, 327). The mechanism of membrane breakdown is not well understood. The acid phosphatase proteins AcpA, B and C seem to play a role in *F.t. novicida* infection as mutants with knockouts of these genes were delayed in phagosomal escape (251). However, deletion of these genes in *F.t. tularensis* Schu4 had no such effect. Despite the deletion of *acpA,B,C* and a resulting 95% reduction in acid phosphatase activity, there was no observed defect in phagosomal escape in murine or human macrophages (75). Once free in the cytosol *Francisella* replicates to large numbers, using up available nutrients and compromising the host cells viability.

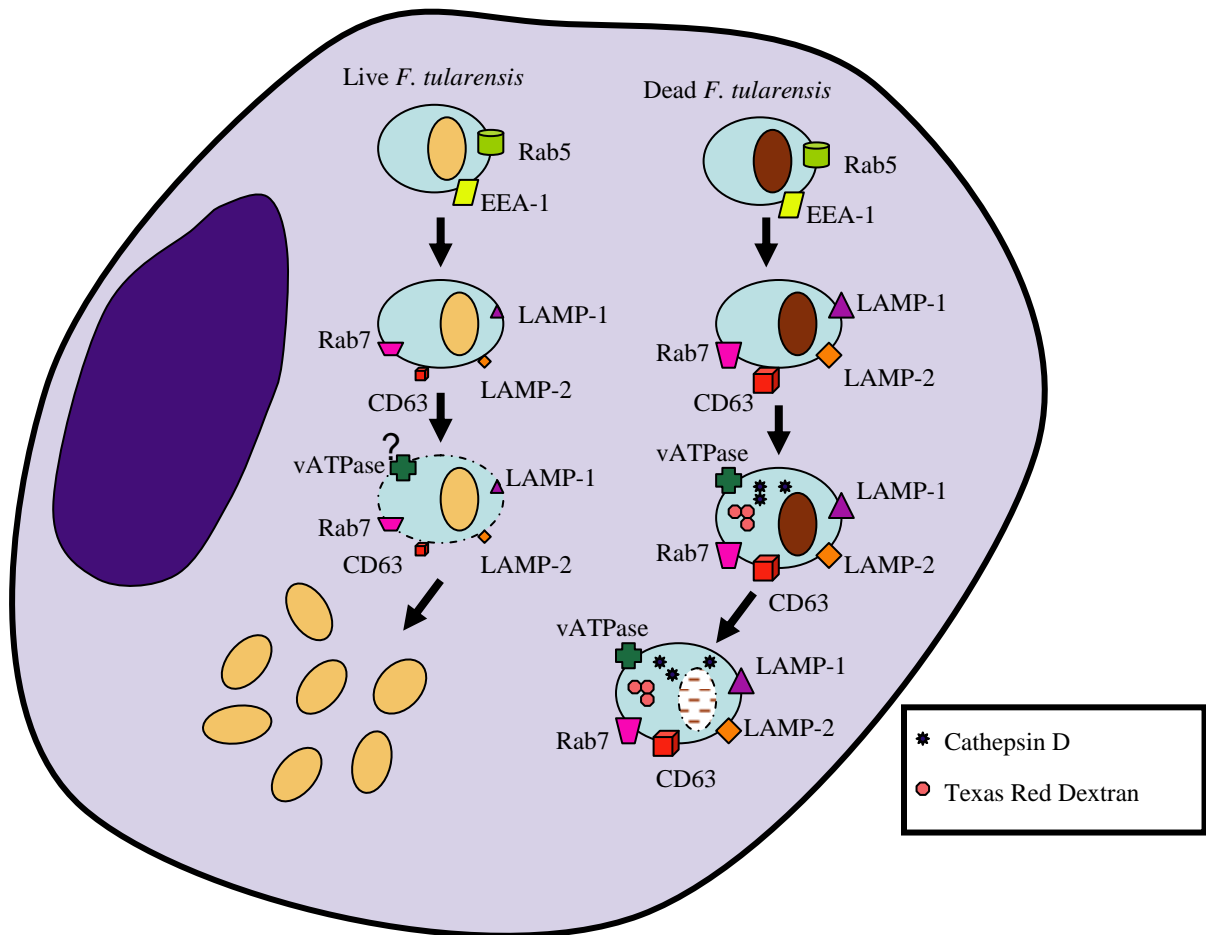

**Figure 2. Maturation of the *Francisella* containing phagosome.** Early phagosome maturation patterns are similar for live and dead *F. tularensis*. Differences are seen in late phagosomal development with live *F. tularensis* containing phagosomes acquiring reduced levels of Rab7, CD63 and LAMPs 1 and 2. Live *F. tularensis* containing phagosomes do not acquire lysosomal proteins such as mature cathepsin D and the bacterium actively degrades the phagosomal membrane. Once free in the host cell cytosol the bacteria begin replication. Phagosomes containing dead *F. tularensis* mature and fuse with lysosomes, becoming acidified and acquiring lysosomal proteins including mature cathepsin D.

This infection leads to subsequent host cell death via both apoptosis and necrosis (180, 206-208). Release of cytochrome *c* and change in mitochondrial potential, coupled with the activation of caspases 9 and 3, indicate activation of apoptosis via the intrinsic pathway rather than the extrinsic death receptor-mediated pathway (208). This activation is dependent on the phosphorylation of p42/p44 MAPK (mitogen-activated protein kinase) and the inhibition of p38 MAPK activity (180, 366). Induction of cellular apoptosis is detected throughout infection with LVS, accompanied by the start of cellular necrosis approximately 30 hours post-infection (180). Apoptotic events are first detected 12-18 hours after infection, approximately 6-12 hours following the start of bacterial replication. Bacterial killing via ciprofloxacin 12 hours post-infection prevents the activation of apoptosis, indicating that bacterial replication is required for the activation (207). This is also corroborated by the fact that infection with deletion mutants defective for phagosomal escape and replication also fail to activate the apoptotic pathway (42, 226, 327). It is likely that activation of apoptosis is induced by the bacterium as this event permits escape from a nutrient depleted host cell without the consequence of inflammation, thus allowing for the infection of new host cells (343). However, the necrosis observed later during infection may be a defensive reaction initiated in response to signalling from other infected cells.

In experiments studying mouse bone marrow derived macrophages infected with LVS, Checroun *et al.* observed the bacteria within double-membrane vacuoles ~20 hours post-infection (71). These vacuoles had fused with secondary lysosomes and were acidified as they acquired endocytosed fluorescent dextran and LysoTracker red. They determined that these vacuoles were endoplasmic reticulum (ER) derived

autophagosomes and may serve as a host cell defence mechanism. However, this observation only seems to hold true for mouse derived cells as there is minimal evidence of this phenomenon in human macrophages (83, 85).

### **1.1.5 Host response to infection**

#### **1.1.5.1 Lipopolysaccharide**

There are more than 10 Toll-like receptors (TLRs) located on the surface of immune cells. These proteins recognize particular ligands, including those found on bacterial pathogens, and after binding induce appropriate immune signalling responses. In order to prevent the host cell from controlling the infection, pathogens must find ways to prevent downstream signalling caused by interaction with these receptors. The most obvious target for recognition of gram-negative bacteria is LPS. The molecules coat the bacterial surface, representing a likely target for immune cell recognition and response. The lipid A portion of LPS is the only component recognized by the innate immune system (160, 377). Human recognition of lipid A classically occurs via TLR4 interaction (160, 244, 250). This activation is coupled by association with myeloid differentiation primary response gene 88 protein (MyD88) and IRAK (IL-1 receptor-associated kinase) which in turn results in the activation of nuclear factor kappa B (NF $\kappa$ B) and subsequent transcription of a vast array of inflammatory genes. These include the synthesis and secretion of cytokines and chemokines as well as inducing the destruction of bacteria within membrane-bound vacuoles. The structure and immunostimulatory effect of LPS varies between bacterial species. The LPS of *Francisella* is unique and exhibits minimal endotoxic properties (15, 165, 321). The decreased stimulatory effects are likely due to

the lack of free phosphates and hypo-acylation of the lipid A molecule which may be the reason that *Francisella* LPS does not stimulate the activation of TLR4 or any other TLR (29, 89, 290, 393, 400). The structure and subsequent lack of LPS immunostimulatory activity is an important virulence factor for *F. tularensis* as several LPS mutants are attenuated in mouse infection models. The LPS structure of *F.t. novicida* differs from the more virulent subspecies taking on a more active form which stimulates several macrophage and monocyte cell lines to secrete pro-inflammatory cytokines such as tumor necrosis factor-alpha (TNF- $\alpha$ ), interleukin-12 (IL-12) and interleukin-1 $\beta$  (IL-1 $\beta$ ) (142, 197, 283). However this stimulation occurs with much less activity than that of *E. coli* LPS (197).

#### **1.1.5.2 Immune response**

The host response to infection involves both innate and adaptive immunity. In the past these were commonly seen as two separate processes, with only adaptive immunity resulting in pathogen-specific recognition and immunity. It is now quite clear that the interaction between elements of the innate and adaptive immune response is complex, dynamic, and constantly evolving. Understanding the immune response to *Francisella* infection is quite complicated particularly because researchers have used a variety of infective strains and host cells or animals to extrapolate vast amounts of information.

Gene and protein expression level analysis of LVS infected mice revealed a profound inflammatory response (152, 153, 356). As this activity is not caused by LPS mediated activation of TLR4, researchers were interested in identifying other possible TLR's involved in recognizing *Francisella*. Several researchers, including Cole *et al.*,

found that the activation of *F. tularensis* infected cells involves Toll-like receptor 2 signalling (89, 92, 194, 217). Certain *Francisella* lipoproteins activate the TLR2/TLR1 heterodimer and other as of yet unidentified proteins activate the TLR2/TLR6 heterodimer (371). This activation is not dependent on LPS but rather on new bacterial synthesis as formalin killed or chloramphenicol treated LVS failed to elicit a TLR2 response (92). TLR2 signalling can occur from within the phagosome and infection with a *Francisella* mutant defective for phagosomal escape significantly increases the expression of certain proinflammatory genes (90, 91). However, studies revealed that TLR2 KO mice are able to control certain types of LVS infection as well as WT mice whereas MyD88 knockout mice are extremely sensitive to infection with LVS (93). MyD88 functions as an adaptor protein for TLR2, -4, -5, -7 and -9 and is necessary for the activation of NF $\kappa$ B. Taken together it seems likely that multiple TLR's or TLR combinations are responsible for the recognition of *Francisella* and subsequent signalling via MyD88.

Early production of proinflammatory and Th1-type cytokines such as interferon-gamma (IFN- $\gamma$ ) and TNF-  $\alpha$  is vital for control of primary *Francisella* infection (356). Treatment of mice with neutralizing antibodies to either of these cytokines at the time of infection with a sublethal dose of *F. tularensis* LVS resulted in rapid death (120, 121, 213). Both TNF- $\alpha$  and IL-12 contribute to control of infection due to their ability to increase IFN- $\gamma$  production and thus nitric oxide (NO) production. It is well documented that LVS infected murine macrophages use reactive nitrogen species including NO and peroxynitrite to kill the invading bacteria (130-132, 219).

The macrophage response to *Francisella* infection relies heavily on data from LVS infection. There is some variation in responses seen depending on the type of macrophage infected and the methodologies employed. It is widely known that both human and murine macrophages support the growth of *F. tularensis*. However, there is a profound proinflammatory response from human leukocytes and very little from murine leukocytes (41, 367). The reason for this difference in response is unknown but may contribute to the avirulence of the LVS strain in the human host.

Humans naturally infected with *F. tularensis*, develop specific IgM, IgG, and IgA serum antibodies within 2 weeks of infection; antibody production peaks roughly 1–2 months after infection can be detected up to 11 years later (201). Passive transfer of antibody has been shown to have a minimal effect on the outcome of infection (11, 114, 372). B cells do not seem to play a crucial role in control and clearance of *Francisella* infection as B cell knockout (BKO) mice follow a very similar course of LVS infection compared to intact mice (73, 119).

Protective immunity to *Francisella* infection relies quite heavily on T cell mediated immunity. Mice lacking mature T cells and given a primary intradermal LVS infection can control bacterial growth for only a few weeks. These T cell deficient mice eventually surrender to devastating bacterial organ burdens within a month of infection (120, 121, 409). Chen and colleagues found that mice given a low-dose Schu4 aerosol infection displayed evidence of thymic atrophy and depletion of CD4<sup>+</sup>CD8<sup>+</sup> thymocytes (72). This implies that *Francisella* may inhibit T cell development or possibly export from the thymus. CD4<sup>+</sup>, CD8<sup>+</sup>, and an unusual CD4<sup>−</sup>CD8<sup>−</sup>NK1.1<sup>−</sup> double negative (DN) T cell population play important roles in the clearing of secondary lethal LVS

infections in mice. These cell populations can efficiently control LVS intramacrophage growth *in vitro*, producing cytokines such as IFN- $\gamma$  and TNF- $\alpha$ . These populations can also individually mediate survival of a primary sublethal LVS infection. However the CD4<sup>-</sup>CD8<sup>-</sup>NK1.1<sup>-</sup> double negative T cells cannot clear a primary intradermal LVS infection. Mice with only these T cells developed a chronic LVS infection. Mice lacking either CD4<sup>+</sup> or CD8<sup>+</sup> T cells (but not both) are able to clear a primary intradermal LVS infection. Mice vaccinated with LVS intranasally require both CD4<sup>+</sup> and CD8<sup>+</sup> T cells for survival of a secondary respiratory challenge with *F.t. tularensis*; depletion of either individual T cell type abrogated protection. Thus it is clear that T cell responses to *F. tularensis* infection can vary depending on the route of infection. In human infection, both CD4<sup>+</sup> and CD8<sup>+</sup> T cell responses are long lived, with considerable levels of proliferation and IFN- $\gamma$  production. It seems that humans elicit a higher frequency of CD4<sup>+</sup> T cell responses than CD8<sup>+</sup> responses. The role of IFN- $\gamma$  appears to be significantly less in secondary infections as opposed to primary infections. TNF- $\alpha$  was the primary arbitrator of the IFN- $\gamma$ -independent control of LVS growth. It can thus be concluded that T cells have other means of controlling and clearing LVS infection.

### 1.1.6 Pathogenicity islands

Pathogenic bacterial species can drastically alter their virulence properties upon the acquisition or loss of genetic loci (139). The gain of new genetic material can occur from a variety of horizontal gene transfer events. These include conjugation, transduction via bacteriophages and transformation (139, 334). Processes such as these

are key factors in the creation of pathogenicity islands thus driving the evolution and adaptation of bacterial pathogens (see Figure 3).

The term pathogenicity island (PAI) was coined by Hacker *et al.* while studying uropathogenic *Escherichia coli* (162). This term is currently used to describe genomic regions present in pathogenic species which are not present in non-pathogenic strains of closely-related or similar species. PAI's contain large blocks of genes that contribute to the virulence of the bacterium such as secretion systems, toxins, and adherence or invasion factors. These regions are characterized by having a guanine-cytosine (GC) content which differs from that of the core genome and are often flanked by tRNA genes, insertion and direct repeat sequences (139, 334). tRNA genes have sequence identity with bacteriophage attachment sites and thus serve as target integration sites (305). Direct repeat sequences are approximately 20 base pair (bp) DNA segments which have nearly perfect sequence repetition. These sequences are homologous to phage attachment sites and are likely duplicated during the integration of mobile genetic elements. Insertion sequences are also sites capable of mediating the integration of mobile genetic elements. However, direct repeats and insertion sequences are frequently recognized by enzymes which excise these genetic elements and can be responsible for PAI instability (163). PAI's also commonly contain mobility factors such as transposases, integrases and phage genes which are commonly responsible for recombination events (139). This combination of elements leads to the spontaneous deletion of PAI's in organisms such as *Helicobacter pylori* and *Yersinia* spp. (139, 163). These deletion events are not common in every species harbouring a PAI as those of *Salmonella* and intestinal *E. coli* seem to be permanently integrated within their respective chromosomes (139).

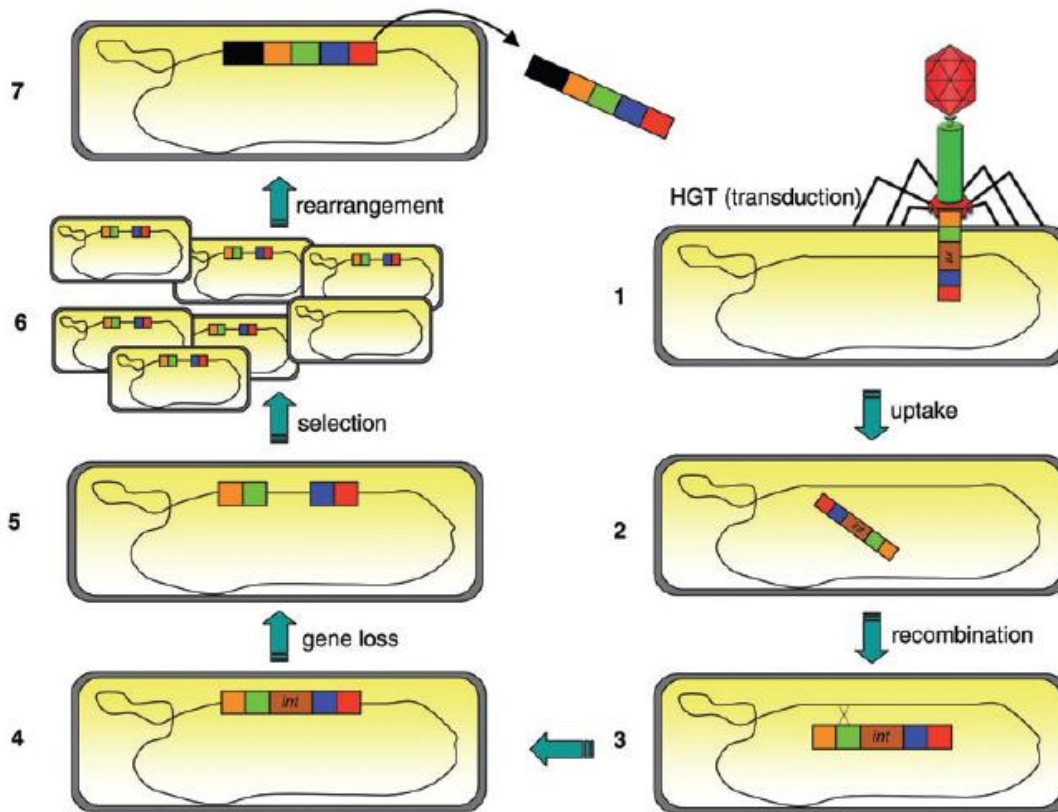

**Figure 3. Horizontal gene transfer resulting in the creation of pathogenicity islands.**

A gene cluster is obtained by a bacterium, through a horizontal gene transfer event, such as transduction from a bacteriophage (1). Following uptake (2), recombination (3) results in the acquired genetic element integrating into the chromosome (4). If genes responsible for mobility of the genetic element are lost the cluster becomes a stably integrated PAI within the chromosome (5). Positive selection will favour the PAI containing variant if the genes encoded within the PAI confer an advantage to the organism. As a result the frequency of the PAI containing variant will eventually increase in the population (6). Genetic rearrangements or new gene acquisitions will likely enhance additional evolution of the PAI. The modified PAI can then be recombined with the environmental gene pool and possibly be transferred to a new microorganism (7).

Adapted from Gal-Mor, O. and B.B. Finlay 2006.

There are several methods used to detect PAI's in bacterial genomes. As previously mentioned there is commonly a difference in the GC content as well as abnormal dinucleotide bias and codon usage (139, 334). This method of screening is very effective but can miss ancient gene transfer or events of gene transfer between species with similar genetic make-ups. Another method which has proven quite successful is to search for genes involved in horizontal gene transfer as mentioned above or genes which are similar to those of distant species. tRNA gene screening has identified genomic islands in *Salmonella*, *Shigella* and *E. coli* (168, 279). A more intensive approach would be to search for unique regions based on direct genome comparison of closely related species.

The acquisition of secretion systems through horizontal gene transfer has been an important factor in pathogen adaptation (334). Since most pathogen's virulence factors have to interact with host cells in order to cause disease the pathogen must then also possess a means of exporting those virulence factors. There are many examples of acquisition of type I, III, IV, V and VI secretion systems as well as their substrates in PAI's (334, 37). The most classic examples of which are the type III secretion systems (T3SS) encoded by the SPI-1 and SPI-2 pathogenicity islands of *Salmonella enterica* and the type IV secretion system (T4SS) encoded by the *cagPAI* of *H. pylori* (68, 334). Type II secretion systems (T2SS) are only known to be coded for in the core genome of bacteria, however there are several examples of their substrate proteins being encoded on PAI's (352).

Like most virulence genes, the genes within PAI's must be tightly regulated and usually respond to stimulation by environmental signals. These signals may include

oxygen level, iron level, pH or bacterial growth phase (169, 334). Control of expression is usually due to a collective regulatory network consisting of regulators contained within the PAI, within other PAI's or within the core genome of the bacterium (334).

### **1.1.7 The *Francisella* pathogenicity island**

The *Francisella* pathogenicity island (FPI) was first discovered by Nano *et al.* in 2004 (263). This discovery was made after transposon mutagenesis revealed 2 loci, *iglA* and *iglC*, within the *iglABCD* (for *intramacrophage growth locus ABCD*) operon were necessary for intramacrophage growth (154). Subsequent bioinformatic analysis of this region revealed the existence of an approximately 30kb pathogenicity island (see Figure 4) (263). The FPI consists of 2 operons; one containing 6 open reading frames (ORFs) including those coding for the Igl proteins, and the second containing 12 ORF's including *pdpA,B* and *C* (for *pathogenicity determinant protein ABC*). The designation of these gene clusters as 2 large operons is speculative as there have not been any studies which analyze the RNA transcripts in detail; thus the operon organization of the FPI may be more complex. The FPI has many of the classic hallmarks of a pathogenicity island. The *pdpA* operon was found to have a GC content of 26.6%; this is 6% lower than the already unusually low GC content of the remaining *Francisella* genome. The *igl* operon also has a lower GC content than the core genome being at 31%. Only the *Plasmodium* species and low GC Gram-positive bacteria have GC contents in this range (262). There are also transposase genes and inverted repeats flanking the pathogenicity island which may provide the capacity for further island mobility (263).

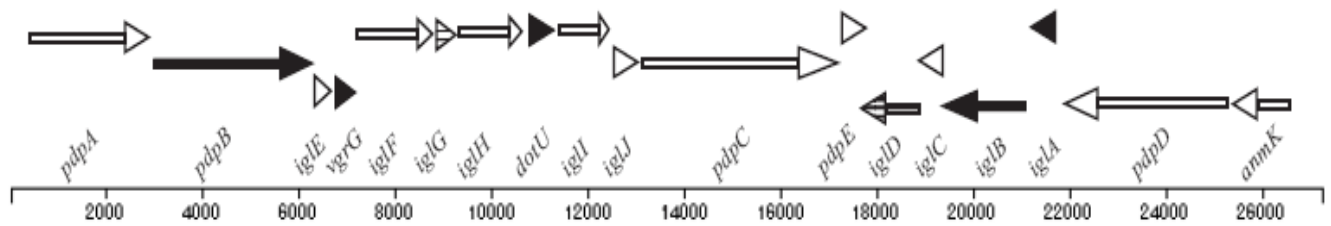

**Figure 4. Diagrammatic representation of the *Francisella* Pathogenicity Island.** The 30kb PAI contains 2 predicted operons; the first comprising genes *pdpA-pdpE* and the second consisting of genes *anmK-iglD*. Black arrows indicate that genes have clear orthologues within type VI secretion systems while striped arrows specify genes with distantly related T6SS orthologues. Adapted from de Bruin *et al.*, unpublished data.

There are some differences in the FPI depending on the *Francisella* subspecies. *F.t. novicida* only contains one copy of the FPI whereas *F.t. holarctica* and *F.t. tularensis* contain two copies. For this reason random mutagenesis of Schu4 and LVS strains frequently fail to identify FPI related virulence genes (195, 299). Early studies using *F.t. novicida* U112 identified several FPI genes associated with virulence and likely accelerated our understanding of the FPI's role in pathogenesis (154, 368). The majority of the FPI is highly conserved between subspecies and strains with one exception. The region upstream of *iglA* which contains the *anmK* and *pdpD* genes varies significantly between the more virulent North American strains of *Francisella* and strains found throughout the Northern Hemisphere (221, 262, 263). *F.t. novicida* contains intact copies of both genes, whereas *F.t. tularensis* Schu4 contains an *anmK* gene which is broken into three ORF's and a *pdpD* gene with a 150bp truncation. The *anmK* and most of the *pdpD*

gene are completely absent from *F.t. holarctica* strains LVS and OSU18 (262, 263). Experiments performed using *F.t. novicida* were able to demonstrate that *pdpD* deletion mutants were attenuated for virulence within chicken embryo and mouse infections but maintained a wild type intramacrophage growth phenotype (221). Deletion of the *anmK* gene had a minimal effect on virulence in a chicken embryo infection. Differences in this region of the FPI may account for some of the difference in virulence seen between *Francisella* subspecies. The remaining proteins encoded by the FPI have very similar amino acid sequences when compared between subspecies and strains. The PdpA protein, for example, is identical in copies of the FPI within a specific strain. There are only 4 amino acid changes between the *Ft. tularensis* and *F.t. holarctica* strains, and these conservative changes should not affect the proteins secondary structure (see Figure 5). There are a higher number of amino acid differences between *F.t novicida* and the other subspecies. This is not surprising considering that *F.t novicida* is considered the oldest subspecies in evolutionary terms; however, most amino acid differences are once again conserved changes (262).

Several FPI gene products have been shown to be required in the intracellular growth of *F. tularensis* however the function of these proteins has yet to be determined (154, 226, 263, 368). Recent evidence indicates that many of the FPI proteins may compose a unique secretion system which will be discussed in detail later in the chapter.

An important issue regarding studies involving *Francisella* is the polarity of the mutants being characterized. As more tools have become available in the study of the FPI proteins it has become clear that many insertion mutants created have had negative effects on downstream gene and protein expression (76, 104, 226). As such previous

conclusions concerning FPI protein roles in bacterial virulence must be carefully scrutinized.

```

OSU18 1 MIAVKDITDLNIQDIISQLTSEVINGDTTSSAKFACEINSYIINYKLNINLINTQLKNTKILYRKGLI
LVS 1 MIAVKDITDLNIQDIISQLTSEVINGDTTSSAKFACEINSYIINYKLNINLINTQLKNTKILYRKGLI
Schu 1 MIAVKDITDLNIQDIISQLTSEVINGDTTSSAKFACEINSYIINYKLNINLINTQLKNTKILYRKGLI
U112 1 MIAVKDITDLNIQDIISQLTSEVINGDTTSSAKFACEINSYIINYKLNINLINTQLKNTKILYRKGLI

OSU18 71 SKLDYEYKRYCVIIRLKNNIDEFILYFSTNYKDSQSLKIAIKELQNSCSSSLILELPHDYIRKIDVLLT
LVS 71 SKLDYEYKRYCVIIRLKNNIDEFILYFSTNYKDSQSLKIAIKELQNSCSSSLILELPHDYIRKIDVLLT
Schu 71 SKLDYEYKRYCVIIRLKNNIDEFILYFSTNYKDSQSLKIAIKELQNSCSSSLILELPHDYIRKIDVLLT
U112 71 SKLDYEYKRYCVIIRLKNNIDEFILYFSTNYKDSQSLKIAIKELQNSCSSSLILELPHDYIRKIDVLLT

OSU18 141 SIDAIAQRSSDLNKTIIKQLNKLSSLSRYIGYNNVLOKQEQITINIKPINKNFELEDISFVSTRNKQYFK
LVS 141 SIDAIAQRSSDLNKTIIKQLNKLSSLSRYIGYNNVLOKQEQITINIKPINKNFELEDISFVSTRNKQYFK
Schu 141 SIDAIAQRSSDLNKTIIKQLNKLSSLSRYIGYNNVLOKQEQITINIKPINKNFELEDISFVSTRNKQYFK
U112 141 SIDAIAQRSSDLNKTIIKQLNKLSSLSRYIGYNNVLOKQEQITINIKPINKNFELEDISFVSTRNKQYFK

OSU18 211 HNSLTLKKNPHIEKLEVCENIYGINGWLTFDLAYINNHKDFNLLSPNQPIIDIOINDSFNFYKKEKSKD
LVS 211 HNSLTLKKNPHIEKLEVCENIYGINGWLTFDLAYINNHKDFNLLSPNQPIIDIOINDSFNFYKKEKSKD
Schu 211 HNSLTLKKNPHIEKLEVCENIYGINGWLTFDLAYINNHKDFNLLSPNQPIIDIOINDSFNFYKKEKSKD
U112 211 HNSLTLKKNPHIEKLEVCENIYGINGWLTFDLAYINNHKDFNLLSPNQPIIDIOINDSFNFYKKEKSKD

OSU18 281 HHKRTTRFMAIGFNSNSIDIHEMFEYSIYSYTKNVSSGVKRIQFHOPFLKALWTKHKPSYIALNKSLOD
LVS 281 HHKRTTRFMAIGFNSNSIDIHEMFEYSIYSYTKNVSSGVKRIQFHOPFLKALWTKHKPSYIALNKSLOD
Schu 281 HHKRTTRFMAIGFNSNSIDIHEMFEYSIYSYTKNVSSGVKRIQFHOPFLKALWTKHKPSYIALNKSLOD
U112 281 HHKRTTRFMAIGFNSNSIDIHEMFEYSIYSYTKNVSSGVKRIQFHOPFLKALWTKHKPSYIALNKSLOD

OSU18 351 IFKDNFFFDNLISLDTNKSNNLKIRIPQAFISTVNRNFYDFFIQOLEQNKCYLKYFCDKKSGKVSYHVVD
LVS 351 IFKDNFFFDNLISLDTNKSNNLKIRIPQAFISTVNRNFYDFFIQOLEQNKCYLKYFCDKKSGKVSYHVVD
Schu 351 IFKDNFFFDNLISLDTNKSNNLKIRIPQAFISTVNRNFYDFFIQOLEQNKCYLKYFCDKKSGKVSYHVVD
U112 351 IFKDNFFFDNLISLDTNKSNNLKIRIPQAFISTVNRNFYDFFIQOLEQNKCYLKYFCDKKSGKVSYHVVD

OSU18 421 QVDNDLQRNIVNSDEDLKDCLSPYDISCFKKQILISNKSIFYVKEKNICPDVTLTQKKEDRKISDTLIR
LVS 421 QVDNDLQRNIVNSDEDLKDCLSPYDISCFKKQILISNKSIFYVKEKNICPDVTLTQKKEDRKISDTLIR
Schu 421 QVDNDLQRNIVNSDEDLKDCLSPYDISCFKKQILISNKSIFYVKEKNICPDVTLTQKKEDRKISDTLIR
U112 421 QVDNDLQRNIVNSDEDLKDCLSPYDISCFKKQILISNKSIFYVKEKNICPDVTLTQKKEDRKISDTLIR

OSU18 491 PFSSILKDNLQSVVEYIQSNDDIQEIIITTFEILLTSRNTLPFLDTEITLSKLDNQNYLLGATDIKSLY
LVS 491 PFSSILKDNLQSVVEYIQSNDDIQEIIITTFEILLTSRNTLPFLDTEITLSKLDNQNYLLGATDIKSLY
Schu 491 PFSSILKDNLQSVVEYIQSNDDIQEIIITTFEILLTSRNTLPFLDTEITLSKLDNQNYLLGATDIKSLY
U112 491 PFSSILKDNLQSVVEYIQSNDDIQEIIITTFEILLTSRNTLPFLDTEITLSKLDNQNYLLGATDIKSLY

OSU18 561 ISQRKLLFKRSKYCSKQLYENLHNFHYKSDSESDVYEKIAFTKYP SLTHDNIITYKIRYSNLTPEYPKY
LVS 561 ISQRKLLFKRSKYCSKQLYENLHNFHYKSDSESDVYEKIAFTKYP SLTHDNIITYKIRYSNLTPEYPKY
Schu 561 ISQRKLLFKRSKYCSKQLYENLHNFHYKSDSESDVYEKIAFTKYP SLTHDNIITYKIRYSNLTPEYPKY
U112 561 ISQRKLLFKRSKYCSKQLYENLHNFHYKSDSESDVYEKIAFTKYP SLTHDNIITYKIRYSNLTPEYPKY

OSU18 631 KSFNFYINGRWTIGENVNNSKAYKFFKNKPEESSIAEFQENGEKGTSAI LNSKADILYAIETAKEM
LVS 631 KSFNFYINGRWTIGENVNNSKAYKFFKNKPEESSIAEFQENGEKGTSAI LNSKADILYAIETAKEM
Schu 631 KSFNFYINGRWTIGENVNNSKAYKFFKNKPEESSIAEFQENGEKGTSAI LNSKADILYAIETAKEM
U112 631 KSFNFYINGRWTIGENVNNSKAYKFFKNKPEESSIAEFQENGEKGTSAI LNSKADILYAIETAKEM

OSU18 701 LSDKSSDKPIITLPLKVNINSANNQFIPLRNDIILIEIQSFTTKGEIIEI LINSNAISTKKAQQQLLQRQL
LVS 701 LSDKSSDKPIITLPLKVNINSANNQFIPLRNDIILIEIQSFTTKGEIIEI LINSNAISTKKAQQQLLQRQL
Schu 701 LSDKSSDKPIITLPLKVNINSANNQFIPLRNDIILIEIQSFTTKGEIIEI LINSNAISTKKAQQQLLQRQL
U112 701 LSDKSSDKPIITLPLKVNINSANNQFIPLRNDIILIEIQSFTTKGEIIEI LINSNAISTKKAQQQLLQRQL

OSU18 771 LGSKENCEMAYTQSDSETFSLTQVNEDECENSFLINDKKGIFLRYKSKGN
LVS 771 LGSKENCEMAYTQSDSETFSLTQVNEDECENSFLINDKKGIFLRYKSKGN
Schu 771 LGSKENCEMAYTQSDSETFSLTQVNEDECENSFLINDKKGIFLRYKSKGN
U112 771 LGSKENCEMAYTQSDSETFSLTQVNEDECENSFLINDKKGIFLRYKSKGN

```

**Figure 5. Amino acid conservation of PdpA.** The amino acid alignment of PdpA from a variety of different *Francisella* species, subspecies, and strains. Most of the differences are attributed to those seen in *F. novicida* U112. The alignment was performed using ClustalW (<http://www.ebi.ac.uk/clustalw/>) and configured for printing using ESprint (<http://esprint.ibcp.fr/ESprint/ESprint/>). Adapted from Nano, F.E. & C. Schmerk 2007.

### 1.1.8 Regulation of the FPI

The differential expression of FPI genes and their products has been observed in response to several environmental stimuli. Broth grown LVS exposed to hydrogen peroxide responded with increased expression of the IglC protein (151, 378). Iron limitation experiments performed by Deng *et al.* demonstrated that low iron conditions induced the threefold upregulation of nearly all FPI genes. However, mass spectrometry analysis of proteins upregulated in low iron conditions failed to detect many of these FPI proteins (214). These conditions reflect those that the bacteria would encounter during a macrophage infection, a situation in which the activation of virulence gene expression is vital.

Several regulatory proteins have been found to influence the expression of FPI genes. The most prominent of these proteins is the global regulator MglA (macrophage growth locus) which shows similarity to the SspA (stringent starvation protein) protein of *E. coli* (30, 70). In *E. coli*, SspA is an RNA polymerase (RNAP)-associated protein which regulates a particular subset of genes in response to stress (184, 406). An early study by Baron and Nano revealed that *mglA* and *mglB* were required for the intramacrophage growth of *Francisella* (30). RT-PCR analysis of an *mglA* mutant revealed greatly reduced expression levels of FPI genes *pdpD*, *igLA*, *iglC*, *iglD*, and *pdpA* (210) and microarray analysis has found that all FPI genes are affected by the absence of *mglA* (51). Charity and colleagues have determined that MglA interacts with an MglA-like protein, annotated SspA. These proteins associate with RNA polymerase in an SspA dependent manner and this association is required for the positive regulation of a variety of stress and virulence genes, including *igLA*, *iglC* and *pdpA* (70). Recent work by Charity

*et al.* also found that the MglA-SspA RNAP complex is controlled by the alarmone guanosine-tetraphosphate (ppGpp) and putative DNA binding protein PigR. Together ppGpp and PigR act as a regulatory checkpoint for this complex, being influenced by environmental and nutritional cues (69). Other transcriptional regulators of the FPI, such as *migR* and *pmrA*, have been identified however little is understood about their modes of action (58, 252).

### **1.1.9 The *Francisella* secretion system**

Many gram-negative intracellular pathogens possess secretion systems, commonly T3SS or T4SS, which they use to secrete virulence factors outside of the bacterium or directly into a host cell. Bioinformatic analysis of the *Francisella* genome failed to detect any type III or IV secretion systems which are commonly responsible for exporting virulence factors (209). The FPI contains several genes which are required for virulence and it is likely that some of these gene products need to be secreted outside the bacterium to perform their function. Bioinformatic analysis revealed that some of the proteins coded within the FPI show similarities to components of the newly discovered type VI secretion system (T6SS) (104). To date, little is known about the T6SS but comparative genomic analysis has revealed their existence within over 90 bacterial species, including *Edwardsiella tarda*, *Pseudomonas aeruginosa*, and *Vibrio cholerae* (255, 297, 414).

The current hallmark for identifying a T6SS is the presence of gene clusters which contain homologues of the IcmF, DotU, IglA and IglB proteins (37). Confirming that a T6SS is functional in a given species is demonstrated through the secretion of an

Hcp-like protein into culture supernatants. This Hcp-like protein secretion is dependent on the IcmF protein (231, 255, 297, 332, 358, 414). *F. tularensis* contains homologues of IcmF, DotU, IglA, and IglB; however the *Francisella* FPI is considered an outlier in type VI secretion (37, 47, 104). This is because many of the proteins within the FPI lack sequence similarity to proteins in other T6SSs and because *Francisella* does not code for an Hcp protein or ClpV, the only known energy source of T6S (37, 47).

It is believed that *Francisella* contains an analogue of the secreted Hcp protein referred to as IglC (de Bruin *et al.*, unpublished data). The *iglC* gene is the most extensively studied within the FPI due to its high levels of expression during intracellular growth (151). Deletion of *iglC* results in the inability of the bacterium to escape the phagosome and replicate intracellularly (218). Although IglC does not appear to share structural similarity with Hcp proteins, their genetic location and secretion patterns indicate that they may share similar functions (103). Hcp proteins are predicted to form tubular structures that span the bacterial membrane and through which transport proteins (28, 255, 298). These structures are thought to be related to the tail tubes of bacteriophages which act as a tunnel through which viral genetic material is transported into the bacterial cell (202). The current assay for demonstrating that the *Francisella* T6SS is functional is the secretion of IglC (221). As IglC is predicted to be a structural component of the secretion system this serves as a surrogate assay until appropriate secreted effectors can be identified (de Bruin *et al.*, unpublished data).

Experiments performed by de Bruin *et al.* determined that 9 of the FPI genes, *pdpB* (*icmF*), *iglABFGHI*, *vgrG* and *dotU*, are required for the secretion of IglC and together form the current predicted model for this secretion system (unpublished data)

(see Figure 6). As in other T6SSs, several of these proteins showed similarities to components of the bacteriophage tail spike apparatus. The *pdpCDE* and *iglDE* genes are not required for IglC secretion and may represent candidate effector proteins delivered by the FPI encoded secretion system. Despite the fact that the *Francisella* secretion system is not considered similar enough to other T6SSs there is no doubt that they share a strong resemblance. This likeness may be the result of a mixture of divergent and convergent evolution through multiple bacteriophage element acquisition events (de Bruin *et al.*, unpublished data).

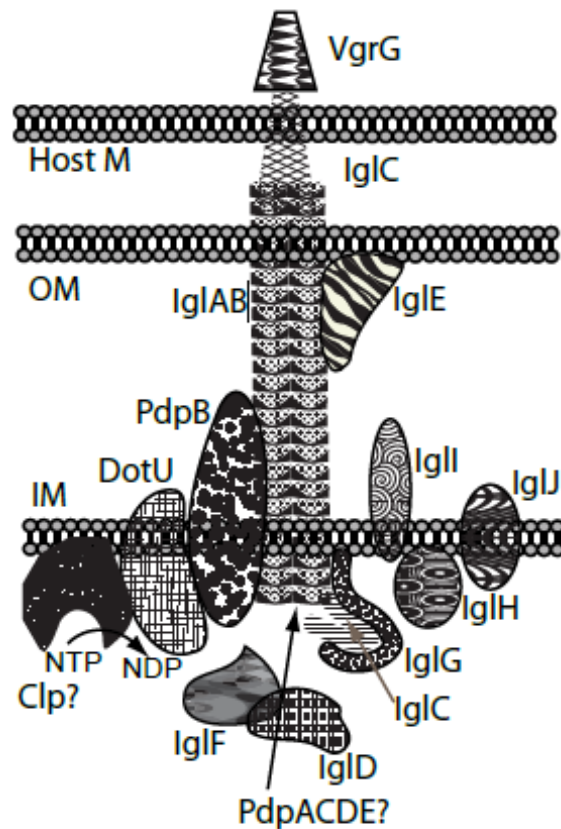

**Figure 6. The *Francisella* secretion system.** This is a predicted model of the secretion system which has been based on protein solubility studies as well as demonstrated protein-protein interactions. Predicted protein roles have also been based on similarity with orthologues in type IV and type VI secretion systems. The IglAB proteins are predicted to form a structure similar to the contracting outer sheath of a bacteriophage puncturing device. IglC is thought to form a tube within the predicted outer sheath through which secreted effector proteins are transported. Adapted from de Bruin *et al.*, unpublished data.

## 1.2 Bacterial manipulation of phagosome maturation

The elimination of invading bacteria from host cells is primarily accomplished by the process of phagocytosis, or more accurately the process of phagosome maturation. Pathogens have developed a wide variety of methods to manipulate and altogether avoid this defence mechanism. These methods fit into one of three broad strategies:

- i) Arresting normal phagosome maturation
- ii) Escape from the phagosome into the host cell cytosol
- iii) Remodelling the phagosomal membrane to create a unique non-phagosomal membrane structure

Many bacterial pathogens are able to utilize these strategies to not only survive within host cells but thrive in them, often with deadly consequences to the host (340).

### 1.2.1 Phagosome maturation

Under normal circumstances macrophages engulf foreign particles, including bacteria. The bacteria are taken up into the newly formed phagosome which undergoes a series of maturation events to become a phagolysosome and kill the invading organism (7, 33, 376). These developmental steps are crucial as newly formed phagosomes are fairly inert and cannot digest their microbial contents. The engulfment process can involve the action of a variety of proteins including protein kinases, phosphatases, GTPases and mediators of membrane fusion and fission (205, 215, 223). The proteins involved in engulfment and the subsequent signalling cascades activated will depend on the receptor-ligand pair utilized (10). TLR2 and TLR4 do not act as phagocytic receptors *per se* but appear to be important in guiding the phagosome maturation path. Involvement

of these receptors directs the microbial load in a path of phagocytosis which will activate an inflammatory immune response and be primed for antigen presentation (38). Such a response would not be desired when digesting “self” particles, as in the process of removing apoptotic cells. Thus not all phagosomes will mature in exactly the same way however there is a basic path of development.

The first maturation step involves interaction with early/sorting endosomes. The early phagosomes are only mildly acidic with a pH of 6.1-6.5 and do not possess much hydrolytic activity. As the name suggests, sorting endosomes discern whether endocytosed material will be recycled or undergo degradation (158, 257). The Rab5 GTPase is a vital regulator of early endosome dynamics. In their active form the Rab GTPases are able to bind to membranous organelles and then bind cytosolic effector proteins which act to further the maturation of the endosome or phagosome (157, 381). Rab5 functions in endosomal motility as well as the fusion of the sorting endosome with endocytic vesicles (350). Many effector molecules responsible for these Rab5 mediated events have not been determined. The best characterized of these effectors is the p150/hVPS34 complex. The p150 component of the complex is a serine-threonine kinase regulatory subunit. hVSP34 is a class III phosphoinositide 3-kinase (PI3K) which is responsible for the formation of phosphatidylinositol-3-phosphate [PI(3)P] (285, 382, 394). PI(3)P binds to effector proteins, keeping them bound to the cytosolic face of the sorting endosome membrane (192, 248, 408). EEA-1 is an important effector held on the endosomal surface by PI(3)P. Dimers of this protein are responsible for tethering sorting endosomes with other endocytic compartments (61, 62, 211). EEA-1 also interacts with SNARE (soluble NSF attachment protein receptor) molecule syntaxin-13 which catalyses

membrane fusion and the ATPase NSF which disassembles SNAREpin complexes after their function has been completed (220, 233, 245, 360). Like EEA-1, hepatocyte growth factor-regulated tyrosine kinase substrate (Hrs) also interacts with PI(3)P and possesses a protein domain which allows interaction with ubiquitinated proteins. Hrs is thought to be required for the segregation of cargo and the initiation of membrane budding (392).

Inhibition of Rab5 or any of these effector proteins prevents the maturation of sorting endosomes and subsequent traffic to lysosomes (56, 77, 78, 233, 392). Upon interaction with early endosomes, newly formed phagosomes acquire Rab5, PI(3)P, EEA-1, Hrs and syntaxin-13 (12, 95, 123, 339, 391, 392). Inhibition of any of these proteins prior to phagocytosis completely halts phagosome maturation (95, 135, 256, 391, 392).

Despite the fact that phagosomes undergo repeated fusion steps with endomembrane vesicles, there is little perceptible increase in the membrane surface area and it encases the internalized particle snugly. This is likely due to the simultaneous fission events occurring which recycle molecules to the plasma membrane and facilitate cargo retrieval by the endosomes and *trans*-Golgi network (46, 349). Also, when components of the phagosomal membrane need to be degraded they are ubiquitinated and associate with the endosomal-sorting complex (ESCRT) which is required for transport to the proteasome (128, 212).

The early phagosome quickly loses markers associated with sorting endosomes and begins acquiring markers correlated with late endosomes. Late phagosomes are more acidic than early phagosomes having a pH between 5.5 and 6.0 and contain many mature proteases (340). Trafficking to late endosomes can occur via lysosomal component containing vesicles from the Golgi or multivesicular bodies from sorting endosomes

(158). Factors regulating late endosome and phagosome dynamics are not well understood. It was originally thought that Rab7 regulated the traffic from early to late endosomes though it is now thought to regulate late endosome to lysosome traffic (57, 127). The release of Rab5 and recruitment of Rab7 appears to be a simultaneous exchange which has been termed Rab conversion, however the mechanism of this action in phagosome maturation is not yet understood (307). The Rab7 effector, Rab7-interacting lysosomal protein (RILP), supports the movement of late endosomes and lysosomes on microtubules (189). The transition from early phagosome to late phagosome is marked by the acquisition of several proteins including Rab7, RILP, the mannose-6-phosphate receptor (M6PR), LAMP-1 and LAMP-2 (158, 257). To date the function of LAMPs 1 and 2 have not been determined. The glycoproteins may be involved in recruiting Rab7 to the phagosome as *Lmp1*<sup>-/-</sup>, *Lmp2*<sup>-/-</sup> null mouse phagosomes are arrested at a Rab5 positive early endosomal stage (181).

Maturation of the phagosome concludes with fusion to lysosomes to create a phagolysosomal compartment. Lysosomes are quite acidic (pH 4.5-5.5) and contain a large amount of mature proteases to degrade targeted components trafficked to the lysosome. There are no clear markers that exclusively identify lysosomes and they are usually identified using pulse-chase experiments with fluid phase markers such as dextran (340). However phagolysosomes are commonly identified by their reduction and/or loss of late endosomal markers such as the M6PR and enrichment of LAMP proteins, mature cathepsins, and vATPases which acidify the phagosomal compartment (46, 82, 112, 389). Inhibition of Rab7 and RILP prevents the fusion of late phagosomes with lysosomes (64, 171, 189). RILP is responsible for moving the phagosome from the

cell edge to the perinuclear area, an essential step in lysosomal fusion. Rab7 and RILP are not the only essential factors involved in the process of phagolysosomal fusion; PI 3-kinase antagonists prevent phagosome maturation yet the late phagosome still acquires Rab7 and RILP (64, 171, 189). Cathepsin acid proteases only become active once the phagosome reaches a sufficiently low pH (216). Once the correct pH environment exists the cathepsins can degrade proteins into peptides in order for them to be loaded onto class I or II MHC (major histocompatibility complex) molecules. Cathepsin D has a role not only in degrading phagosomal contents but also in activating MHC Class II proteins, which is crucial for peptide loading (55, 301). Once the phagolysosome has fully matured most microbial contents are efficiently degraded in the highly acidic and oxidizing environment (167, 361).

### **1.2.2 Arresting phagosome maturation**

Intracellular bacteria such as *S. enterica Typhimurium* and *M. tuberculosis* have the ability to halt the maturation of the phagosome to prevent exposure to deadly components of the lysosome environment.

*S. typhimurium* has two type III secretion systems required for virulence which are encoded within two pathogenicity islands (SPI-1 and SPI-2) (169). SPI-1 delivers proteins required for invasion into non-phagocytic cells. These factors induce ruffling of the host cell membrane which results in uptake of the bacterium into a *Salmonella* containing vacuole (SCV) (133). Once in the SCV a different set of proteins are expressed by SPI-2 and secreted into the host cell cytosol. The expression of these proteins only occurs after invasion as a response to environmental cues such as reduced

Ca<sup>2+</sup> and Mg<sup>2+</sup> concentrations and low pH (108, 141). These effector proteins are required for the intracellular survival of *Salmonella* and many of them are likely involved in altering the maturation of the SCV (79, 176, 269). There is now evidence that some translocated effectors of SPI-1 also play a role in these SCV maturation steps and are not just involved in bacteria-mediated invasion (48, 88, 354, 401). The SCV acquires all of the early phagosomal markers, including Rab5, EEA-1 and PI(3)P (355). The vacuole then progresses to what appears to be a late endosome, gaining LAMP-1 and Rab7 (140). The SCV can continue to mature and fuse with lysosomes as indicated by the acquisition of vATPase, cathepsin D and experiments using lysosomes loaded with the fluid-phase marker rhodamine dextran, however this does not occur with all SCVs (53, 99, 242, 341). The vacuole environment triggers the expression of SCV altering proteins which create a specialized vacuole conducive to bacterial survival. Although the SCV appears to be undergoing a fairly normal process of phagosome maturation, there are several differences observed in experiments by Smith *et al.* (347). The  $\Delta invA/inv$  strain of *S. typhimurium* lacks the SPI-1 T3SS and is degraded in the phagolysosome. Comparison of the SCV Rab acquisition and retention patterns between this and wild type strains revealed important distinctions. The wild type SCV acquires and retains very high levels of Rab5 which are never obtained by the mutant SCV. This acquisition is likely due to the action of *S. typhimurium* SPI-1 effector SopB. SopB is an inositol phosphate phosphatase capable of dephosphorylating many inositol polyphosphates and phospholipids (268, 415). This protein performs a variety of functions during infection and seems to be responsible for recruiting Rab5 to the SCV which in turn increases the amount of PI(3)P present as well (227). SopB is also involved in recruiting sorting nexin

protein 1 (SNX1), a host phosphoinositide-binding protein, to the SCV. SNX1 removes M6PR containing membrane, preventing the delivery of lysosomal hydrolases (59).

There are other examples of such events as Rab11 and syntaxin 13 recruitment resulted in recycling of factors important in the acquisition of LAMP-1 (346). As such it seems that *Salmonella* is able to effectively recruit recycling factors to the SCV to remodel this compartment. There are also many Rabs which are actively excluded from the wild type SCV, including those that promote phagosome-lysosome fusion (347). The majority of effectors and /or mechanisms involved in these processes remain unknown.

Another mechanism utilized by *Salmonella* is the alteration of cholesterol content mediated by SseJ, a glycerolphospholipid-cholesterol acyltransferase (271). SseJ localizes to the SCV and esterifies cholesterol, increasing lipid droplets in host cells (264, 271). This is a novel strategy which effectively interferes with host cell trafficking.

The wild type SCV acquires Rab7 and RILP more quickly than SPI-1 mutant SCVs (347). These proteins are needed to move the SCV along microtubules to the perinuclear region, in close proximity to the Golgi network (159, 170, 230). *Salmonella* induced filaments (Sifs) are formed along the microtubule scaffold which are Rab7 dependent but do not require RILP (170). Actin based myosins have also been implicated in the positioning of SCV's during infection, revealing a coordinated tug of war between actin and microtubules in the positioning of the SCV; however the benefit of this system to *S. typhimurium* is not yet understood (27, 401). This complex series of modifications to phagosome maturation results in the formation of a vacuole which sustains large amounts of bacterial replication and is a vital process in *Salmonella* virulence (27).

*Mycobacteria* do not invade cells like *Salmonella*; instead they are ingested by professional phagocytes. Once engulfed, *M. tuberculosis* and *M. leprae* are able to modify phagosome maturation and avoid the host immune response often resulting in an infection that can last years (340). The path of phagosome maturation in response to *Mycobacterial* infection varies depending on the entry receptor used. If the complement or scavenger receptors are utilized the phagosome maturation is stalled and the bacteria survive (117, 333); however if the bacteria are opsonized by antibody and taken up via Fc receptors the phagosome matures normally and *Mycobacteria* are killed (23, 24).

Early endosomal marker Rab5 is quickly acquired by the *Mycobacterium* containing phagosome however late endosomal markers Rab7 and LAMP-1 are never acquired, even days after infection (389). This suggests that the maturation of *Mycobacterium* containing phagosomes is arrested at an early phagosome state. Closer analysis of the early phagosome revealed that although some PI(3)P was present on the membrane, its tethered effector proteins EEA1 and Hrs were not (135, 392). This represents a likely reason for the stall in phagosome maturation as EEA1 and Hrs are crucial in this process. Vergne *et al.* discovered that lipoarabinomannan (LAM) released from the bacterial cell wall inhibits the production of PI(3)P. This is accomplished by LAMs ability to inhibit Ca<sup>2+</sup> fluxes. Ca<sup>2+</sup> is necessary for the recruitment of the PI3K hVPS34 complex and subsequent PI(3)P production on the phagosomal membrane (385). *M. tuberculosis* goes one step further and also secretes a lipid phosphatase, SapM, which is able to dephosphorylate PI(3)P on the phagosomal membrane surface (317, 386). The action of these two proteins is able to effectively prevent the formation of new PI(3)P and remove any that does happen to be produced, thus halting phagosome maturation.

### 1.2.3 Escape from the phagosome

Like *F. tularensis*, several bacterial pathogens utilize a strategy which allows them to escape the phagosome and reside within the host cell cytosol. Many of these bacteria, including *Shigella flexneri*, *Listeria monocytogenes*, and *Rickettsia* species, polymerize actin following escape, allowing them to easily travel throughout the cytosol and invade new cells. As described previously, *Francisella* has a unique survival strategy following phagosome escape which does not involve actin polymerization. Although very little is known about the mechanisms that *Francisella* uses to escape the phagosome, several escape strategies have been revealed in other bacteria.

*S. flexneri* invades epithelial cells much like *S. typhimurium* does however upon internalization *Shigella* quickly degrades the phagosome membrane. *S. flexneri* has a 30kb locus within a large virulence plasmid which is homologous to SPI-1 of *S. typhimurium* (6). The T3SS encoded in this locus is required for the secretion of effector proteins IpaB and IpaC, which are able to interact with and destabilize lipid membranes (105, 106). These proteins are required for phagosomal escape but their mechanism of action is not fully understood (31, 241, 282, 419). There is some evidence that IpaB and IpaC may interact with the proteins IpaA and IpgD to form a pore within lipid membranes (106). IpaD has also been shown to be important in regulating the secretion of the Ipa proteins and the insertion of IpaB and IpaC into the host cell membrane (292).

All species of *Rickettsia* are able to invade host cells and quickly escape the phagosome prior to phagolysosomal fusion (126, 164, 370, 398). Sequencing of *Rickettsial* genomes revealed the presence of several genes with the potential to disrupt

the phagosomal membrane, including *tylC* and *pld* (17, 236). TylC was found to have haemolysin activity and Pld exhibits phospholipase D activity (300, 306). Due to the inability to create knockout mutants in *Rickettsia*, Whitworth *et al.* introduced *tylC* and *pld* into *S. typhimurium* and found that these transformants were now able to break down the phagosomal membrane and escape into the host cell cytosol. Pld seems to play the predominant role in escape as nearly 100% of these *Salmonella* transformants were able to break down the vacuolar membrane whereas only 20% of TylC transformants were able to (404).

*L. monocytogenes* has the best characterized phagosomal escape mechanism among intracellular bacteria. The causative agent of listeriosis can enter a variety of host cell types by inducing uptake or via phagocytosis (383). Once the bacterium escapes the phagosome it can replicate to large bacterial numbers within the cytosol; this membrane disruption depends on the combined activities of phospholipases C (PLCs) and listeriolysin O (LLO) (63, 138, 193, 295, 335, 348). LLO is a member of the largest family of pore forming toxins, the pore-forming cholesterol-dependent cytolysins. These toxins are usually made by extracellular pathogens such as *Clostridium perfringens* and *Streptococcus pyogenes* (335). Toxin monomers homo-oligomerize to form pre-pore complexes which insert themselves into membrane bilayers (101, 144, 145, 374). Formation of the large pore is dependent on the presence of cholesterol (144, 186). *L. monocytogenes* escape is dependent on the acidification of the phagosomal compartment; the acidified phagosome reaches a pH of approximately 5.9 before membrane integrity is disrupted (32). Studies suggest that this is not due to differences in LLO activity at varying pH levels but rather the acidification inducing the synthesis and

release of LLO and other proteins, including phosphatidylcholine-specific phospholipase-C (PC-PLC) (148, 229). Due to the required combined actions of the PLC proteins and LLO in membrane degradation it cannot simply be assumed that the pore formed by LLO results in the destruction of the phagosomal membrane. Currently, the most accepted model of action is that LLO is able to slow the maturation of the phagosome, preventing phagolysosome fusion and allowing the PLC proteins to perform their functions (74, 175, 335). Prior to rupture the *L. monocytogenes* containing phagosome is Rab5 and LAMP-1 negative but Rab7 positive (175). It is thought that this stall at the late endosomal stage is mediated by LLO disruption of proton and calcium gradients required for phagosomal maturation (175, 342). This model of LLO action is also supported by the work of Cheng *et al.* When host cell components required for the fusion of late endosomes and lysosomes were knocked down LLO was not needed for phagosomal escape but the PLC proteins remained essential (74).

#### **1.2.4 Creation of unique membrane structures**

Rather than prevent phagosome maturation or disrupt the membrane to escape into the cytosol, some pathogens choose to alter the phagosomal membrane structure to create unique organelles which provide a safe haven for the bacterium to replicate (see Figure 7).

*L. pneumophila* causes Legionnaires disease in humans but is normally a protozoan parasite (44). Once taken up by professional phagocytes *L. pneumophila* quickly alters the normal path of phagosomal maturation and does not acquire Rab7 or LAMP-1 at early time points (84, 190, 313). Instead of maturing into a late phagosome

the *Legionella* containing vacuole (LCV) acquires components of the endoplasmic reticulum (ER) through the actions of secreted bacterial virulence factors. The secretion of these effector proteins is accomplished by *Legionella*'s Dot/Icm dependent T4SS (309). If the transmembrane protein DotA is absent, rendering the secretion system inoperable, the LCV follows normal maturation patterns and fuses with lysosomes (313). ER derived secretory vesicles are recruited and fuse to the LCV through the action of the bacterial effector proteins DrrA and RalF. DrrA binds to the LCV in a phosphatidylinositol-4-phosphate [PI(4)P] dependent manner and displaces the inhibitor of Rab1 (49, 182, 224). The protein then acts as a nucleotide exchange factor and activates Rab1 which is required for the ER derived vesicle fusion (225, 259). Rab1 is normally involved in regulating the targeting and fusion of ER-derived vesicles with the Golgi complex (128). The *L. pneumophila* effector LidA acts with DrrA to enhance Rab1 recruitment to the LCV but is not essential in this process (225). When Rab1 activity is no longer required the T4SS effector LepB deactivates the GTPase by promoting GTP hydrolysis (182). Another host GTPase, ARF-1 (ADP-ribosylation factor 1), which is involved in ER vesicle trafficking is recruited to the LCV. The bacterial effector RalF acts as an ARF-1 specific nucleotide exchange factor thus regulating its activity and promoting the fusion of ER derived vesicles to the LCV (260). Eventually the recruited ER vesicles fuse to form a large, ribosome studded vacuole surrounding the bacterium (375). *L. pneumophila* mutants deficient in DrrA or RalF can still survive within macrophages and thus the bacterium likely possesses redundant mechanisms responsible for LCV formation which have not yet been identified (128, 260). There are more than 80 T4SS dependent proteins which have been linked to the

infective process, many of which contain motifs found in eukaryotic proteins (8, 183, 284). It is likely that *Legionella* manipulates a wide range of host cell pathways to facilitate intracellular growth and virulence.

The maturation of the LCV resembles host cell autophagy, a process whereby the ER engulfs cytoplasmic materials and degrades them once the autophagosome acquires LAMP-1, lysosomal hydrolases and the proton ATPase (13, 359). Indeed after the ER surrounds *L. pneumophila* the LCV begins to acidify slightly but does not possess all characteristics of mature autophagosomes. The mature LCV acquires limited amounts of degradative enzymes and the presence of ribosomes in the LCV membrane is not a characteristic of autophagy (359). There is some argument as to whether the LCV must be acidified in order for the bacteria to replicate but it is quite apparent that interaction with the ER is vital in the *L. pneumophila* infective process (128, 357, 405). It is currently unknown whether the pathogen induces autophagy upon infection or whether this is a host cell defensive response due to the recognition of a faulty phagosome.

*Coxiella burnetii* is an obligate intracellular pathogen with two distinct developmental lifecycles. Phase 1 *Coxiella* is an infectious small cell form and Phase 2 *Coxiella* is a large cell form which can replicate intracellularly (397). Phase 1 *Coxiella* induces phagocytosis through interaction with the leukocyte response integrin ( $\alpha V\beta 3$ ) (65). The signalling cascade induced via this interaction is unique to phase 1 *Coxiella* as phase 2 *Coxiella* fails to elicit the same response, even upon engagement of  $\alpha V\beta 3$  (238). The newly formed phagosome appears to follow normal maturation patterns but fusion with the lysosome is slowed by the bacterium (174, 311). This is due to the recruitment of autophagosome markers such as monodansylcadaverine and microtubule-associated

protein1 light chain 3 (LC3)(34). Interaction with the autophagosome pathway is thought to be important in slowing lysosomal fusion to allow time for the bacterium to transition to its replicative phase 2 form (161). The inhibition of early autophagic processes via the addition of wortmannin and 3-methyladenine prevented the formation of *Coxiella* vacuoles (34).

The mature *Coxiella* phagolysosome acquires acid phosphatase, cathepsin D, LAMPs 1 and 2, and becomes highly acidified by vATPase (pH 4.8) (174, 232). This environment would be considered inhospitable to most bacteria yet *C. burnetti* thrives in it, unable to replicate intracellularly without acidification of the vacuole (174). In order to protect the bacterial chromosome from reactive oxygen species present in the lysosome *Coxiella* induces an SOS DNA repair system (243). There must be several other bacterial effectors responsible for *Coxiella*'s successful adaptation to this environment however they have not been identified. It is likely that the T4SS encoded by the pathogen is responsible for the secretion of important effector proteins (128, 284).

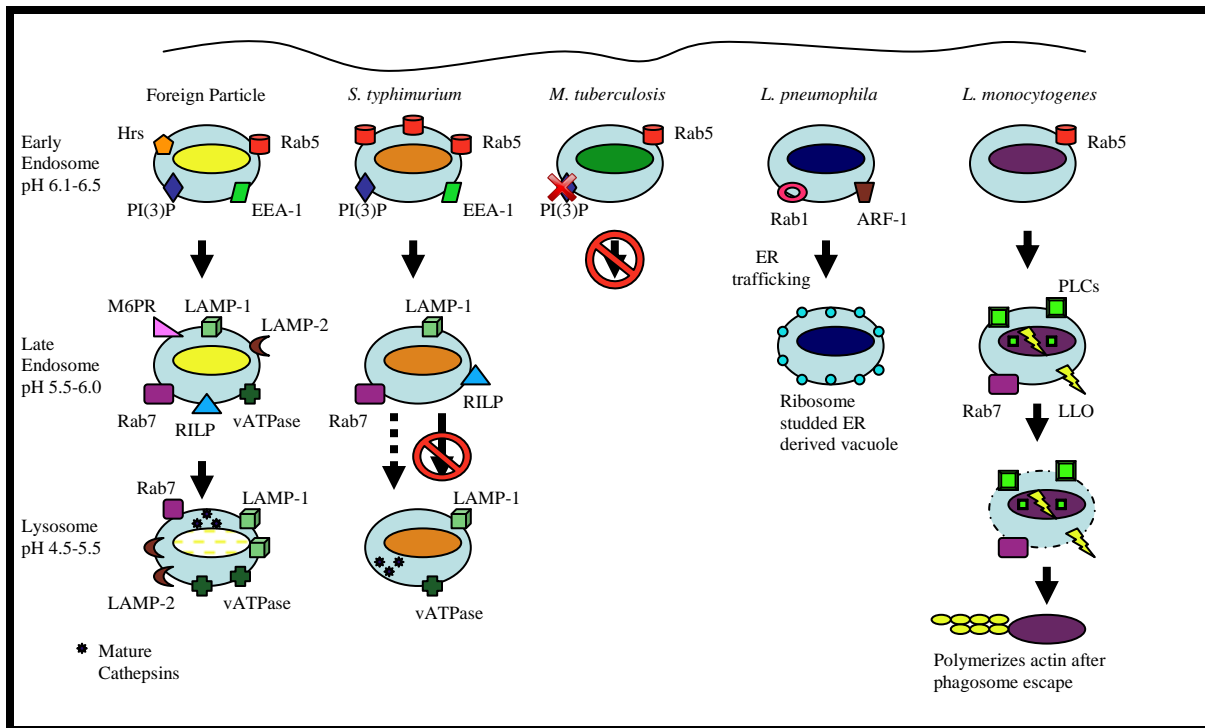

**Figure 7. Alteration of phagosome maturation by bacterial pathogens.** Normally, particles or microorganisms are engulfed within a phagosome which matures to an early endosome-like stage. The early endosome is loaded with Rab5, containing EEA-1 and other Rab5 effectors that identify the site of vesicle binding during fusion. The *M. tuberculosis* phagosome lacks Rab5 effectors that are required for future endosomal fusion and does not fuse with late endosomes. The *L. pneumophila* containing phagosome quickly diverges from the normal endocytic maturation pathway, interacting with ER derived components to become a ribosome studded ER derived vacuole. Foreign particle and other bacteria containing phagosomes mature to a late endosome that acquires Rab7, Lamps, and the M6PR. The vesicle becomes acidified via acquisition of the ATPase proton pump and fuses to lysosomes. Note that the *S. typhimurium* late endosome-like phagosome lacks the M6PR late endosomal marker. In most cases the SCV maturation arrests at a late endosome-like stage but will occasionally mature and fuse with lysosomes. *L. monocytogenes* escapes the late phagosome via the action of phospholipases (PLC) and listeriolysin O (LLO). Foreign particles and microorganisms which cannot subvert the normal phagocytic pathway will fuse with lysosomes and be degraded.

### **1.3 Bacterial pathogens and ubiquitination**

Pathogens must alter many host cell defences in order to successfully replicate within the host and cause disease. The uptake of microbes and subsequent process of phagocytosis is accompanied by the activation of a wide variety of signalling cascades which trigger an immune response. Ubiquitin mediated protein modification and degradation is essential in the host immune response to infection and bacteria have evolved a number of mechanisms to interfere with and subvert these ubiquitin pathways (19, 315, 351).

#### **1.3.1 The many roles of ubiquitin**

Ubiquitination is a post translational modification that controls several aspects of cellular metabolism, including transcriptional regulation, signal transduction, cell cycle progression and pathogen immune response (196, 345). Ubiquitin (Ub) is a highly conserved 76 amino acid protein (149). Ubiquitination involves the addition of Ub monomers to target proteins or to Ub itself to create poly-Ub chains (see figure 8). This ubiquitination can result in changes in the localization or activity of the target protein or signal for its degradation. The covalent addition of Ub occurs at the  $\epsilon$ -amino group of lysine residues and is accomplished via the action of at least three enzymes: an Ub-activating (E1) enzyme, an Ub-conjugating (E2) enzyme and an Ub ligase (E3) (288). The E1 enzyme activates the C-terminus of Ub in an ATP-dependent manner and then directs the Ub to the active site of the E2 enzyme. The E2 Ub-conjugating enzyme interacts with one of two types of E3 ligases, HECT (homologous-to-the-E6-AP-carboxyl-terminus) and RING (really-interesting-new-gene) or U-box ubiquitin ligases.

The E3 ligases catalyze the bonding of activated Ub to its target protein (19, 315, 351) (see figure 8). HECT-type E3s directly bind to ubiquitin before adding it to the substrate whereas RING-type E3s bridge E2 enzymes carrying activated Ub to the target protein, without being covalently bonded to the Ub itself (22). The RING-type E3 ligases can act alone or as part of multiprotein complexes such as the SCF complex (Skp, Cullin, F-box containing complex). In the SCF complex the E3 ligase acts as the catalytic subunit with help from the adaptor protein cullin and an F-box protein which is responsible for binding the specific target protein (22, 288).

The fate of ubiquitinated proteins depends on the E2 and E3 ligases acting upon it as well as the length of the Ub chain and type of linkages occurring within it. If the Ub chain is 4 residues or more linked via lysine 48 (K48) the protein is targeted for degradation via the 26S proteasome (291, 373). The proteasome unfolds the protein and digests it into smaller peptides (3-20 residues) which can be further degraded by downstream aminopeptidases (294, 345). Polyubiquitin chains linked through K63 regulate a variety of processes including DNA repair, endocytosis, cellular signalling and vesicular trafficking. Monoubiquitination directs subcellular protein localization, recruitment of Ub-binding proteins and endocytosis. Though prokaryotes contain homologues and probable ancestors to components of the 26S proteasome and E1 and E2 ligases they do not perform the process of ubiquitination (40, 185).

An important function of the Ub system involves the host cell response to invading pathogens. Activation of TLRs recruits adapter proteins and activates E3 ligases such as TNF receptor associated factor-6 (TRAF-6). TRAF-6 subsequently ubiquitinates the NF $\kappa$ B essential modulator (NEMO) protein which induces a kinase

signalling cascade. The inhibitor of NF $\kappa$ B (I $\kappa$ B) is then ubiquitinated and degraded by the proteasome. Once this occurs the active NF $\kappa$ B protein is able to enter the nucleus and activate the transcription of a variety of immune response genes (36, 351).

The process of ubiquitination is reversible and accomplished by deubiquitinating enzymes (DUBs). DUBs are usually cysteine proteases and only take on their active conformation upon binding to Ub which prevents non-specific protease activity (265). These enzymes function in recycling Ub, proofreading Ub conjugates, processing Ub precursors and removing inhibitory Ub chains from target substrates (14, 265). The importance of ubiquitination and deubiquitination in cellular function make the pathway a desirable target of bacterial pathogens and as such it is no surprise that many have distinct mechanisms by which they interfere with this process.

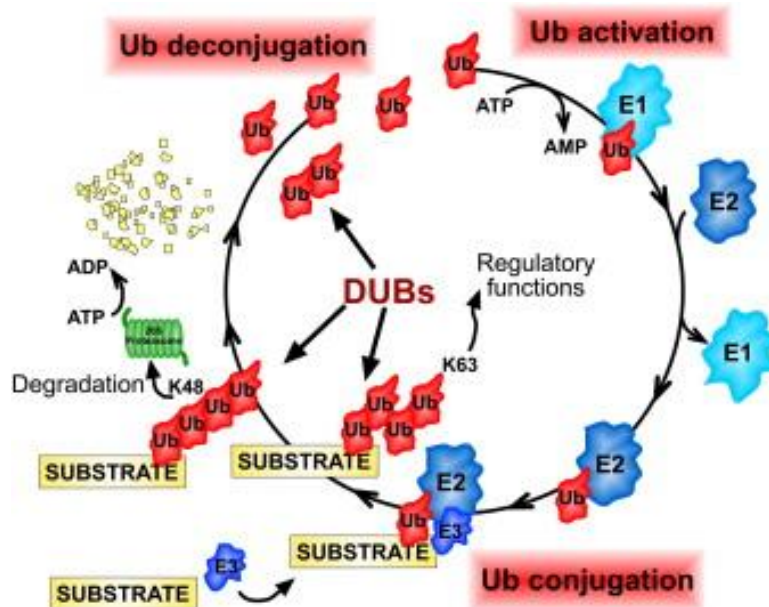

**Figure 8. The eukaryotic ubiquitination pathway.** E1 ligase enzymes activate ubiquitin in an ATP-dependent manner. Ubiquitin is then directed to an E2 ligase enzyme. E3 ligases transfer ubiquitin using one of two methods: (1) The E2 ligase enzyme transfers ubiquitin to the E3, and then to the substrate (2) The E3 ligase acts as an adaptor binding to E2 ligases and substrates separately. The E3 then aids in the direct transfer of Ub from the E2 enzyme to the substrate. Ub chains of at least four molecules linked via lysine 48 (K48) of Ub direct the modified protein to the 26S proteasome to be degraded. Proteins which are polyubiquitinated via K63-linkage are involved in regulating a multitude of cellular processes. Ubiquitin molecules can be removed from modified proteins by deubiquitinating enzymes (DUBs). These enzymes are important in proofreading Ub protein conjugates and removing Ub from modified proteins when necessary. Adapted from Rytkonen, A., and D. W. Holden 2007.

### 1.3.2 Bacterial interference with ubiquitination involved in host immune response

Protein posttranslational modifications (PTMs) regulate a range of cellular signalling pathways, including the innate immune response. Phosphorylation and ubiquitination are important PTMs that bacteria can target in a variety of ways to dampen the host immune response to infection.

There are three *Yersinia* species that cause disease in humans. These pathogens encode a T3SS which secretes various effector proteins called Yops (*Yersinia* outer proteins). One of these effector proteins, YopJ, is an important inhibitor of the host macrophage inflammatory response and inducer of apoptosis (249, 258, 416). When macrophages are infected with a *Y. pseudotuberculosis* strain that contains a mutated YopJ there is a build up of ubiquitinated I $\kappa$ B $\alpha$  in the macrophage cytosol. This led researchers to discover that YopJ is able to cleave both K48 and K63 linked poly-Ub-chains and thus prevent the destruction or activation of multiple Ub-conjugated proteins including TRAF6 and I $\kappa$ B $\alpha$  (416). Failure to ubiquitinate I $\kappa$ B $\alpha$  prevents the activation of NF $\kappa$ B and the multitude of signalling cascades that follow. This versatile protein can even remove the monoubiquitin linked to I $\kappa$ B kinase beta (IKK $\beta$ ), a regulator of I $\kappa$ B $\alpha$  activity, which is required for NF $\kappa$ B activation (66). YopJ has also been found to have acetyltransferase activity. This acetyltransferase activity is able to prevent signalling via MAPK (mitogen-activated protein kinase) kinases such as MAPKK6 (39, 249, 258). This type of action may allow YopJ to prevent the phosphorylation of proteins such as IKK $\beta$ , further preventing the activation of NF $\kappa$ B (258). This interference with MAPK and NF $\kappa$ B signalling pathways prevents the expression of pro-inflammatory cytokines IL-8 and TNF- $\alpha$  and activates apoptosis (97, 246, 254, 277, 410, 417). There

are homologues of YopJ expressed in a variety of pathogens including *Salmonella* (AvrA), *Xanthomonas* (AvrBst) and *Ralstonia* (PopP1) indicating that this is a very effective strategy in manipulating host defences (276).

The *S. flexneri* effector OspG is also able to regulate the activation of NF $\kappa$ B by interfering with the degradation of I $\kappa$ B $\alpha$  (198). Instead of actively removing Ub, OspG binds to UbcH5, the E2 Ub-conjugating ligase responsible for adding Ub to I $\kappa$ B $\alpha$ , inhibiting its function. OspG displays kinase activity which results in its autophosphorylation however it is not known how this activity is involved in the proteins function in inhibiting E2 ligase activity. Because OspG can bind to several E2 ligase enzymes it is likely that the effector plays a role in interfering with several host cell pathways (19, 198).

Plant pathogens such as *Pseudomonas syringae* also manipulate ubiquitination in order to alter host immune responses. The T3SS effector HopM1 is able to suppress the plant cell wall-associated defence by mediating the proteasome-dependent degradation of AtMIN7, an important protein involved in vesicle trafficking via the activation of Ras-like GTPases (107, 240, 267). Vesicle trafficking has proved to be a significant factor in plant immunity (35, 94, 107, 173). HopM1 does not seem to have any ligase activity of its own and researchers suggest that it may act as an adaptor protein which mediates the detection of AtMIN7 by the plant ubiquitin proteasome system (267).

### **1.3.3 Bacterial effector proteins modified by ubiquitination**

The ubiquitin proteasome system acts to degrade proteins that are no longer required by the host cell. This system is also used by bacteria for the same purpose.

There are several examples of T3/4SS effector proteins that are destroyed by the proteasome when they are no longer needed by the bacterium. This technique can be used to prevent excessive damage to the host cell which is needed for bacterial colonization or allow short lived activation or alteration of specific host cell pathways.

The *S. typhimurium* T3SS effectors SopE and SptP are able to alter the actin cytoskeleton in opposing ways. SopE is able to activate Rac-1 (Ras-related C3 botulinum toxin substrate 1) and Cdc42 (cell division control protein 42), two Rho GTPases involved in the reorganization of the cytoskeleton. This change in the actin cytoskeleton enables the uptake of *S. typhimurium* into target epithelial cells. The effector protein SptP is a GTPase-activating protein that can deactivate Rac-1 and Cdc42 (136). This deactivation occurs several hours after infection and causes the actin cytoskeleton to return to its normal form. In order to effectively infect the host cell the activity of these proteins must be sequentially regulated. Kubori and colleagues found that although equal amounts of these effectors were secreted early during infection SopE levels quickly decreased. The diminishing levels of SopE were due to its polyubiquitination and subsequent degradation via the host cell proteasome. SptP was also found to be degraded via the proteasome but with much slower degradation kinetics. The rate of degradation was found to be mediated by the effectors secretion and translocation domains; swapping the secretion and translocation domains of SptP with those of SopE resulted in the rapid degradation of SptP. Conversely, if SopE was secreted using the domains of SptP the protein remained in the host cell much longer, continually altering the actin cytoskeleton (203).

*S. typhimurium* secretes two more effectors which are regulated by host cell ubiquitination, SopA and SopB. SopB, whose role in SCV maturation was previously discussed, is monoubiquitinated and degraded within the host cell. As monoubiquitination does not target proteins for degradation by the proteasome, Marcus *et al.* speculate that the modification of SopB acts to downregulate its activity, possibly by targeting SopB for lysosomal degradation (228). The T3SS effector SopA is involved in inducing intestinal inflammation. It is ubiquitinated by the membrane-anchored E3 ligase HsRMA1 and then degraded by the proteasome (412). Although *Salmonella* primarily replicates within SCVs there are some bacteria which escape into the cytosol of epithelial cells where they are able to replicate at a significantly faster rate than in the SCV (52, 54, 289). It is currently unknown whether this escape is beneficial to *Salmonella* pathogenesis. Researchers hypothesize that SopA activity is responsible for bacterial escape from the SCV as *sopA* mutants escape the SCV less frequently than wild type *S. typhimurium*. This SopA mediated escape from the SCV is HsRMA1 dependent (412). SopA appears to play a multifunctional role in infection and also displays HECT-type E3 Ub ligase activity (413). This activity does not appear to play a role in escape from the SCV but instead seems to be implicated in the transepithelial movement of polymorphonuclear neutrophils (PMNs). Recruitment of these cells is an important factor in the development of *Salmonella*-induced enteritis. The target proteins ubiquitinated by SopA have not yet been identified but may play a part in the recruitment of PMNs (413).

*Yersinia* seems to have adopted a similar strategy to *Salmonella* with regards to regulating rearrangements of the actin cytoskeleton for the benefit of the pathogen.

However, *Yersinia* is acting instead to prevent bacterial uptake via phagocytosis as this results in the death of the pathogen. YopE of *Y. pseudotuberculosis* provokes the depolymerization of actin filaments through the inhibition of Rho GTPases (390, 395). This activity also prevents host cells from forming membrane pores which facilitate cell death thus allowing for extended host colonization (390). During infection with *Y. enterocolitica* YopE is polyubiquitinated on lysine K75 and degraded by the proteasome (314). It is not yet known whether this action is done for the benefit of the host or the bacterium. Removal of YopE may allow other T3SS effectors, such as YopT and YopO, to modify the actin cytoskeleton (115, 314). However, the degradation products of YopE may also provide a useful antigen source to help the host fight infection (314, 384).

#### **1.3.4 Bacterial mimicry of host proteins involved in ubiquitination**

The mimicry of host proteins is a useful virulence strategy which can be brought about primarily by two mechanisms, convergent evolution and horizontal gene transfer (113, 351, 353). In cases of convergent evolution the production of a new effector protein with structural characteristics similar to a host protein results in a functional mimic. In these instances there is no primary sequence similarity between the two proteins and similarities are often seen once the crystal structures are solved. Horizontal gene transfer events result in the pathogen maintaining and altering acquired eukaryotic genetic material. In this case a eukaryotic gene is transferred and incorporated into the genome of a bacterium and successfully expressed under the control of a prokaryotic promoter. If the newly acquired gene confers an advantage in virulence to the organism the mimicking variant will be selected for within the bacterial population (351).

AvrPtoB is a well characterized structural mimic found in the plant pathogen *P. syringae* pv. *tomato* DC3000 (187, 199, 353). The N-terminus of AvrPtoB induces plant hypersensitive response (HR) mediated cell death and the C-terminus controls cell death suppression (3). AvrPtoB is able to suppress HR mediated cell death in plants that do not possess a *Pto* resistance gene; the *Pto* gene confers gene-for-gene resistance to *Pseudomonas syringae* pv. *tomato* (199, 353). The C-terminus of AvrPtoB functions as a RING type E3 Ub ligase and can autoubiquitinate (2, 187). Interference with the proteins autoubiquitination or recruitment of E2 Ub enzymes ablates the suppression of host cell death and renders the pathogen avirulent. AvrPtoB target host cell proteins have not been identified but would likely be those responsible for inducing HR mediated host cell death (2, 187). AvrPtoB does not contain any primary sequence homology to eukaryotic E3 Ub ligases; similarities were only found at a structural level indicating that this protein function has likely evolved through convergent evolution (187).

The remaining proteins being discussed in this section are likely the result of horizontal gene transfer as they share obvious sequence homology with their eukaryotic counterparts. *Agrobacterium tumefaciens* is a plant pathogen which causes crown gall disease and utilizes its T4SS in a very unique way. Not only does the T4SS secrete effector proteins into the plant cell, but it also transfers single stranded transfer DNA (T-DNA) into the cell which is inserted into the host genome (19, 146, 388). The T4SS effector VirF is required for virulence and is the first prokaryotic protein found to contain an F-box domain (179, 239, 336). As previously mentioned, F-box proteins function as part of the SCF type E3 Ub ligase complex, recruiting the protein which will be targeted for proteasome destruction (111). F-box proteins normally interact with Skp1 (S-phase

kinase-associated protein 1) within the SCF complex; VirF is able to interact with yeast Skp1 homologues via its conserved F-box domain (336). The host protein VIP1 (VirE2-interacting protein 1) is targeted for degradation by VirF and this results in the indirect destruction of the T4SS effector protein VirE2, likely because VIP1 directly interacts with VirE2 (380). VirE2 is secreted into the host cell independently of the T-DNA and then binds to the DNA to protect it from degradation and assist its nuclear uptake (4, 67, 312, 387, 418). VIP1 may function as an adaptor between VirE2 and karyopherin- $\alpha$ , a protein which aids in nuclear import upon recognition of a protein's nuclear localization signal (80). Tzfira *et al.* have hypothesized that VirF promotes nuclear-proteasome dependent degradation of Vip1 and thus VirE2 since the two proteins interact. This may facilitate the uncoating of the T-DNA prior to its integration into the host cell genome (380). Plant cell proteins involved in host defence have been identified as possible targets for ubiquitination by VirF but these interactions have not yet been confirmed (19).

*Ralstonia solanacearum* is another plant pathogen which is able to cause bacterial wilt in a variety of hosts (100, 147, 316). This bacterium secretes effectors via its T3SS; these effectors include a family of seven F-box containing proteins (18). Each of these proteins also contains a leucine rich repeat domain which contains a conserved GAXALA motif and as such these effectors are called GALA proteins. The GALA proteins can interact with a large number of yeast Skp1 homologues and appear to have redundant functions as no one GALA protein is required for virulence in *Arabidopsis* or tomato plants (18, 100, 137, 308). Only deletion of all 7 GALA proteins significantly reduced *R. solanacearum* virulence in tomato and *Arabidopsis* (18). However, deletion of only the *GALA7* gene drastically reduced the virulence of this pathogen in *Medicago truncatula*.

The wild type phenotype was restored by a full length GALA7 gene but not one where the GALA7 F-box domain had been deleted (18). The proteins ubiquitinated by the GALA proteins have not been discovered, so it not known if the targets are host proteins or bacterial T3SS effectors.

The discoveries concerning bacterial pathogens and their interaction with the eukaryotic ubiquitin proteasome pathway have revealed a vast array of methods which pathogens can use to manipulate host processes. Concurrently, the studies performed leave a large amount of information still to be exposed. Furthermore, genome sequencing is significantly adding to the number of candidate bacterial genes which may be involved in manipulating ubiquitin related pathways (19, 351).

#### **1.4 Research objectives and dissertation outline**

Though most genes within the *Francisella* pathogenicity island are required for the intracellular growth and/or virulence of the pathogen, very little is known regarding the function and mode of action of these gene products. As well, most *Francisella* studies to date have been performed using polar transposon or allelic replacement mutants which can mask the true phenotype of FPI mutants.

The purpose of this dissertation is to characterize the expression and localization of the *pdpA* gene product as well as study the effects of non-polar *pdpA* deletion and mutagenesis on the intracellular growth and virulence of *F. novicida*. These efforts are made to ultimately determine the function of *Francisella*'s PdpA protein.

The introductory chapter discussed the current knowledge of *Francisella tularensis*, including its history, disease pathology, and intracellular lifestyle. The

intracellular lifestyle of other bacterial pathogens was also examined with a focus on pathogen modulation and exploitation of the phagocytic pathway and host cell ubiquitination machinery. Chapter 2 will characterize the expression and subcellular localization of PdpA and describes the creation of a non-polar  $\Delta pdpA$  mutant and its effect on *Francisella* virulence. The intracellular growth and LAMP-1 association of the  $\Delta pdpA$  mutant is studied in chapter 3. This chapter also examines the host cell mRNA response to infection with wild type *F. novicida* and the  $\Delta pdpA$  strain. The fourth chapter studies the mutagenesis of a putative conserved F-box domain within PdpA and the resulting effects on the mutant strains intracellular growth and virulence. Chapter 4 also describes experiments performed to ascertain whether the PdpA protein is secreted into the host cell as well as detect possible interacting proteins. Conclusions and future studies will be discussed in the fifth chapter.

## Chapter 2: Characterization of the pathogenicity island protein PdpA and its role in the virulence of *Francisella novicida*.

(*Microbiology* (2009), **155**, 1489–1497.)

Crystal L. Schmerk,<sup>1</sup> Barry N. Duplantis,<sup>1</sup> Diana Wang,<sup>1</sup> Robert D. Burke,<sup>1</sup>  
Alicia Y. Chou,<sup>2</sup> Karen L. Elkins,<sup>2</sup> Jagjit S. Ludu<sup>1</sup> and Francis E. Nano<sup>1</sup>

<sup>1</sup>Department of Biochemistry and Microbiology, University of Victoria, Victoria, BC, Canada

<sup>2</sup>Center for Biologics Evaluation and Research, Food and Drug Administration, Rockville, MD, USA

### 2.1 Introduction

*Francisella tularensis* is a Category A bioterrorism threat and is the causative agent of the zoonotic disease tularaemia. The closely related bacterium *Francisella novicida* is unable to cause disease in healthy individuals; however, it causes a disease in mice that is very similar to human tularaemia and, as such, is a useful tool for studying *Francisella* virulence factors. Both *F. tularensis* and *F. novicida* grow vigorously in macrophages, with a life cycle that includes transient localization in a phagosome followed by growth in the host-cell cytosol (20, 87, 130, 150, 296). Little information is available concerning the function of virulence factors that contribute to *F. tularensis* infection. Many of the genes that have been shown to be necessary for intracellular growth and virulence are located within the recently discovered *Francisella* pathogenicity island (see Figure 9) (262, 263). The FPI is about 28 kb in length and contains 16–19 genes, depending on the biotype and strain. Recent bioinformatics analysis indicates that several genes within the FPI encode products that are homologues of components of type VI secretion systems (T6SSs) (104, 221). *F. novicida* contains one copy of the FPI whereas *F. tularensis* strains that have been examined contain two copies of the genomic island (262).

Disruptions of a number of genes within the FPI have been shown to severely reduce intracellular bacterial growth (104, 150, 154, 206, 210, 263, 327, 368, 402). However, in most cases the phenotype of mutants could not be unequivocally demonstrated to be the result of the inactivation of a specific gene, since polarity effects were not studied nor genetic complementation performed. It is probable that most FPI genes contribute to intracellular growth and virulence, and deletion mutagenesis and complementation studies have provided strong evidence that *iglA* and *iglC*, two of the genes in the *anmK-iglD* operon (see Figure 9) are absolutely required for intramacrophage growth.

Regulation of FPI gene expression has been linked to several factors. MglA is the best studied of the *Francisella* global regulators (30, 51, 70). Studies of gene regulation in *Francisella* have revealed that FPI-encoded mRNA species are depressed in an *mglA* mutant. The MglA protein has been shown to bind RNA polymerase complexes, but its direct role in affecting mRNA levels of FPI genes has not yet been established. Low iron concentrations also increase the level of mRNA for several FPI-encoded mRNA transcripts (109). Mass spectroscopy analysis has shown that IglA, IglB, IglC, IglD and PdpB are all increased in low-iron conditions (109, 214). Immunoblot analysis has shown that both iron concentration and MglA play a role in IglA expression. It is clear that other regulatory proteins, such as FevR, SspA and PmrA, also affect expression of FPI genes (50, 70, 252).

The *pdpA* gene is 2.46 kb in size, representing one of the largest ORFs in the FPI (262). A gene replacement in *pdpA* was made as part of the initial characterization of the FPI, and the resulting mutant was unable to grow in macrophages and was avirulent in

mice (263). We now know that the replacement mutant had polar effects on downstream genes, resulting in decreased expression of PdpB and increased attenuation in chicken embryos (this chapter). It is likely that the *in trans* complementing plasmid recreated the intact operon by integration into the chromosome. In this chapter we examine the expression and characteristics of the PdpA protein as well as the phenotype of a non-polar deletion mutant of *pdpA*.

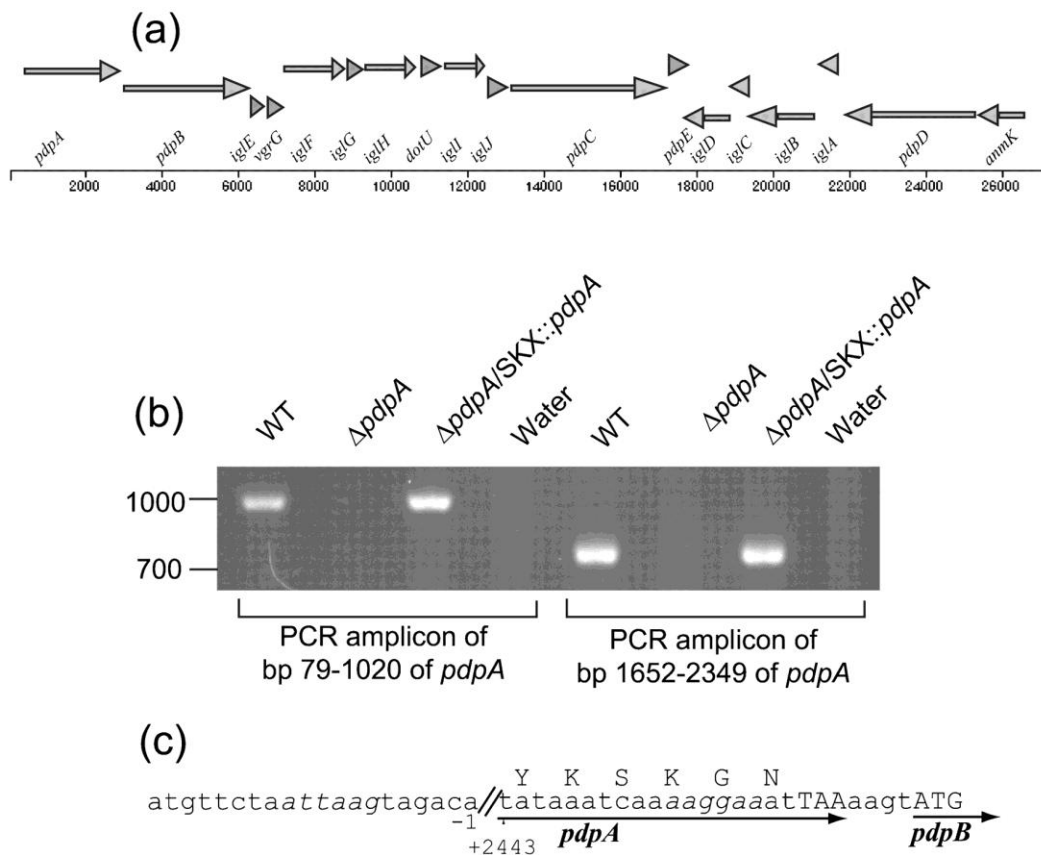

**Figure 9. Deletion of *pdpA*.** (a) The *pdpA* gene is the first cistron in a low-G+C operon of the *Francisella* pathogenicity island (FPI). A newly revised nomenclature is used to show the two convergent operons in the FPI. (b) Primers that amplify regions within the *pdpA* gene were used to screen wild-type (WT) *F. novicida*, the  $\Delta pdpA$  mutant and the *in cis* complement  $\Delta pdpA/SKX::pdpA$ . (c) The exact nucleotides removed to create the  $\Delta pdpA$  mutant are shown. The in-frame deletion preserves the last 21 nucleotides of *pdpA*, which contain the ribosome-binding site (shown in italics) of the downstream gene *pdpB*.

## 2.2 Materials and Methods

### 2.2.1 Bacterial strains and growth conditions

The bacterial strains and plasmids used in this study are listed in Table 1. *Escherichia coli* strains were grown using Luria Bertani (LB) broth or agar supplemented with 250 µg ampicillin ml<sup>-1</sup>, 30 µg kanamycin ml<sup>-1</sup> or 100 µg erythromycin ml<sup>-1</sup>, as required. *F. novicida* and *F. tularensis* strains were grown using trypticase soy agar or broth supplemented with 0.1 % (w/v) cysteine (TSAC, TSBC). When necessary, 30 µg erythromycin ml<sup>-1</sup> or 15 µg kanamycin ml<sup>-1</sup> was added. For negative selection in deletion mutagenesis experiments, sucrose was added to TSAC to a final concentration of 10 % (w/v).

### 2.2.2 Mutagenesis and complementation

To create the *pdpA* deletion mutant strain the upstream and downstream regions flanking the *pdpA* gene were joined using fusion overlap PCR and the resulting amplicon was cloned into pWSK29 to create pWSK29:: $\Delta$ *pdpA*. The last 22 bp of *pdpA* were left to preserve the ribosome-binding site of *pdpB* (see Figure 9). The insert from pWSK29:: $\Delta$ *pdpA* was excised using *XhoI*, ligated to the *XhoI-XhoI sacB-Em<sup>R</sup>* cassette from pJL-ES-X, and the ligation reaction was used to transform *F. novicida* JL0. The integration and excision of the *sacB-Em<sup>R</sup>* cassette was used to create a markerless deletion of the *pdpA* gene as previously described (221). The *F. novicida* JL0 strain was used as the wild-type strain in order to maintain an isogenic background for mutants and complemented strains, as the integrating plasmid used for complementation inserts at the non-essential locus FTN\_1390 that is deleted in the JL0 strain. The  $\Delta$ *pdpA* mutant was complemented using

the kanamycin integration vector pJL-SKX (222) that inserts into the chromosome via a double crossover recombination event. The full-length *pdpA* gene and the promoter region, 522 bp upstream of *pdpA*, were ligated to pJL-SKX. The vector was then linearized and used to transform the *pdpA* deletion mutants, creating *in cis* complementation strains. The sequence of the genomic regions in the *pdpA* deletions has been deposited with GenBank and assigned the number EU810409. The sequences of the primers used in all the genetic constructs will be made available upon request.

### **2.2.3 SDS-PAGE and immunoblotting**

All SDS-PAGE was carried out using standard techniques. The Bradford (Bio-Rad) protein assay was used to determine sample protein concentration and normalize the amount of protein loaded in each lane. Once separated, the proteins were transferred to an Immobilon-FL PVDF membrane (Millipore) and then blocked in 5 % skim milk in PBS, pH 7.4. Mouse monoclonal antibody against PdpA was added at a 1:2000 dilution, whereas mouse monoclonal antibodies against PdpB and IglB were used at a 1:4000 dilution. Rabbit polyclonal antibody against MglB was used at a 1:5000 dilution. Bound antibody was detected using IRDye800-conjugated goat anti-mouse or IRDye800-conjugated goat anti-rabbit antibody (Rockland Immunochemicals) and visualized, and the integrated intensity of fluorescence quantified, using the LiCor Odyssey imaging software version 2.1. The anti-PdpA monoclonal antibody was produced by immunizing mice with recombinant C-terminal portion (aa 405–783) of PdpA expressed from pET28a. The anti-PdpB and anti-IglB antibodies were also produced by immunizing mice with recombinant protein expressed from pET28a. The mouse anti-PdpA hybridoma developed in this research, and the hybridomas producing anti-IglB and anti-PdpB, have

been deposited with the American Type Culture Collection's Biodefence and Emerging Infections Resources program.

#### **2.2.4 Iron-limitation studies**

*F. novicida* strains were grown overnight in TSBC at 37 °C without shaking. Then 3 ml of overnight culture was added to 30 ml fresh TSBC and allowed to grow for 1 h at 37 °C while shaking at 200 r.p.m. After 1 h the cultures were split into three flasks. One flask was left untreated and deferoxamine mesylate salt (Desferal) was added to the other two flasks to a final concentration of 1 mM. FeSO<sub>4</sub> (1 mM) was also added to one of the Desferal-containing flasks. Bacterial cultures were grown for a further 2 h. Cells were harvested by centrifugation at 1000 g for 15 min and resuspended in PBS, pH 7.4, containing protease inhibitors (Sigma). Cell suspensions were sonicated with five 30 s pulses and then prepared for SDS-PAGE and Western blotting as described above.

#### **2.2.5 Subcellular fractionation of *F. novicida***

*F. novicida* U112 was added to J774A.1 macrophages at an m.o.i. of 1000:1 (bacterium to macrophage). Infected monolayers were incubated for 1 h at 37 °C, 5 % CO<sub>2</sub> in complete Dulbecco's Modified Eagle Medium (cDMEM) supplemented with 10 % (v/v) fetal bovine serum (FBS) and 4 mM L-glutamine. Macrophages were washed five times in sterile PBS (Invitrogen) and fresh growth medium was added. The infection was allowed to progress for 18 h, at which point the macrophages were lysed by adding deoxycholic acid to a final concentration of 0.1 % (w/v). Bacteria were separated from the macrophage lysate by centrifugation at 2000 g for 15 min. The bacterial pellet was resuspended in PBS and sonicated to lyse cells. Any unbroken cells were removed by

centrifugation at 10 000 *g* for 10 min. A sample was taken at this point as the total protein fraction. The cell lysate was ultracentrifuged at 100 000 *g*, 4 °C (Beckman ultramicrocentrifuge TLA-100.3) for 2 h to pellet the membranes. The supernatant representing the soluble proteins was removed and ultracentrifuged once more for 30 min at 100 000 *g*, 4 °C to minimize membrane protein contamination. The pellet representing the membrane-associated proteins was washed once in PBS and ultracentrifuged once more for 30 min at 100 000 *g*, 4 °C. The membrane-associated protein pellet was then treated with 1 % (w/v) sodium lauroyl sarcosinate (Sarkosyl) and left at room temperature for 30 min. The inner membrane (Sarkosyl-soluble) and outer membrane (Sarkosyl-insoluble) fractions were separated by ultracentrifugation at 100 000 *g* at 4 °C for 2 h. The fractions were then processed for SDS-PAGE and immunoblotting as described above. To estimate the amount of inner-membrane protein associated with each fraction, the NADH oxidase activity was determined using the method described by Osborn *et al.* (278). Fraction purity was determined by comparing relative enzyme activity per milligram of protein per fraction.

### **2.2.6 Chicken embryo infections**

Fertilized White Leghorn chicken embryos were incubated for 7 days prior to infection. After incubation, embryos were infected with the appropriate strains of *F. novicida* in a range of doses as described by Nix *et al.* (266). After infection, embryo death was monitored over a period of 6 days; the results of one inoculating dose are presented.

### 2.2.7 Mouse infections

For *in vivo* infections, 6- to 8-week-old male specific-pathogen-free BALB/cByJ mice were purchased from the Jackson Laboratory. Animals were housed in sterile micro-isolator cages in a barrier environment at the Center for Biologics Evaluation and Research. Mice were fed autoclaved food and water *ad libitum*, and all experiments were performed under Institutional Animal Care and Use Committee guidelines. Mice were given 0.1 ml of appropriately diluted bacteria intradermally at the base of the tail; actual doses of inoculated bacteria were simultaneously determined by plate count. All materials used in animals, including bacteria, were diluted in PBS (BioWhittaker) containing  $<0.01$  ng endotoxin  $\text{ml}^{-1}$ .

### 2.2.8 Graphing and statistics

The Prism GraphPad v4.03 software was used to create graphs and determine statistical values. For comparison of different survival curves the log-rank test was used to generate *P*-values.

**Table 1. Bacterial strains and plasmids used in the deletion of *pdpA*, the creation of its complement and the characterization of the PdpA protein.**

Strain or plasmid	Characteristics	Source or reference
<b>Strains</b>		
U112	Wild-type <i>F. novicida</i>	ATCC 15482
JLO	U112 with deletion in FTN_1390, where SKX vector inserts; identical growth and virulence with respect to U112	(222)
GB2	U112 with point mutation in global virulence regulator, <i>mglA</i>	(30)
GB6	U112, <i>mglB</i> : : mTn10Km <sup>R</sup>	(30)
SC92	U112, O-antigen gene : : Em <sup>R</sup>	(98)
<i>F. tularensis</i> subsp.	Live vaccine strain, type B biotype	ATCC

<i>holarctica</i> LVS		29684
<i>F. tularensis</i> subsp. <i>tularensis</i> B38	Attenuated type A biotype strain	ATCC 6223
$\Delta pdpA$	JLO with a deletion of <i>pdpA</i>	This study
$\Delta pdpA/SKX::pdpA$	$\Delta pdpA$ complemented with the integrating pJL-SKX : : <i>pdpA</i> construct	This study
$\Delta pdpA$ -LPS NZ9	$\Delta pdpA$ , O-antigen gene : : Em <sup>R</sup> from SC92 U112, <i>pdpA</i> : : Em <sup>R</sup> gene replacement mutant.	This study Laboratory strain
$\Delta pdpA/SKX::pdpA$ -LPS	$\Delta pdpA/SKX$ : : <i>pdpA</i> , O-antigen gene : : Em <sup>R</sup> from SC92	This study
<i>E. coli</i> DH5 $\alpha$	F <sup>-</sup> <i>supE44</i> $\Delta(lacZYA-argF)U169$ ( $\phi 80lacZ\Delta M15$ ) <i>hsdR17</i> ( $r_K^- m_K^+$ ) <i>recA1 endA1 gyrA96 thi-1 relA1 <math>\lambda^-</math></i>	Invitrogen
<i>E. coli</i> BL21 (DE3) pLysS	B F <sup>-</sup> <i>dcm ompT hsdS</i> ( $r_B^- m_B^-$ ) <i>gal</i> $\lambda$ (DE3) [pLysS Cm <sup>r</sup> ]	Stratagene
<b>Plasmids</b>		
pWSK29	Low-copy cloning vector, Ap <sup>r</sup>	(399)
pJL-SKX	pWSK29 with integrating SKX cassette, Km <sup>r</sup> , Amp <sup>r</sup>	(222)
pJL-ES-X	pWSK29 containing an <i>ermCsacB</i> cassette with flanking <i>XhoI</i> restriction sites	(222)
pWSK29:: $\Delta pdpA$	A clone containing the fused flanking regions of <i>pdpA</i> ; used to create the <i>F. novicida</i> $\Delta pdpA$ mutant	This study
pJL-SKX:: <i>pdpA</i>	An integrating complementation construct containing the full <i>pdpA</i> gene and its predicted promoter region (522 bp upstream of <i>pdpA</i> start)	This study
pET 28a	Expression vector with 6xHis and T7 tags	Invitrogen
pET 28a:: <i>pdpA</i> -C	Clone expressing amino acids 405–783 of PdpA with a carboxyterminal 6xHis tag. Used to create the monoclonal antibody against PdpA	This study

## 2.3 Results

### 2.3.1 Detection of PdpA with monoclonal antibody

The *pdpA* gene is the first in an AT-rich, 12-cistron operon in the FPI (Figure 9); it is 2463 bp in length, and encodes a predicted 820 aa (95 kDa) protein. The deduced

protein shows greater than 97 % amino acid identity across all sequenced strains of *Francisella*. The PdpA protein lacks a *sec*-associated signal peptide, and does not show significant similarity to other proteins by standard BLASTP analysis. However, iterated BLAST analysis (PSI-BLAST) suggests the presence of a eukaryotic F-box motif, which is often found in ubiquitin–ligase complex-associated proteins. Analysis of PdpA using HHpredict software also detects several protein domains associated with the ubiquitin-proteasome pathway.

Although we previously used a genetic approach to demonstrate that PdpA plays a role in virulence, there has been no biochemical evidence demonstrating the expression of PdpA. To detect the product of the *pdpA* gene we developed a monoclonal antibody against a recombinant fragment of PdpA, and used it in Western immunoblots of *F. novicida* and *F. tularensis* extracts. As can be seen in Figure 10(a), the PdpA band in *F. novicida* often runs as a distorted band of relative molecular mass of approximately 90. In the *F. tularensis* subsp. *holarctica* strain LVS or the *F. tularensis* subsp. *tularensis* strain B38 the PdpA band migrates as a tight band at a relative molecular mass of approximately 82. *F. novicida* has an O-antigen structure and banding pattern that is different from that found in *F. tularensis* strains and this may account for the distortion of the PdpA band that occurs in *F. novicida* but not in *F. tularensis* extracts.

To add confidence that the reactive band seen in immunoblots was truly PdpA, we created a deletion mutant that eliminated codons 1–813 of *pdpA* (Figure 9 b,c); the last seven codons were not deleted in order to preserve the ribosome-binding site of *pdpB*. The deletion mutation was verified by PCR analysis (Figure 9b) and by sequencing of the

genomic region of the  $\Delta pdpA$  mutant. We also complemented the  $\Delta pdpA$  mutation by inserting *pdpA* and the region encompassing 522 bp upstream of *pdpA* into an integrating vector, pJL-SKX, which inserts into the chromosome at approximately 507 kb from the *pdpA* locus. As mentioned, we reasoned that the distortion of the PdpA band was due to its co-migration with several LPS bands that are present in *F. novicida* but not in *F. tularensis* at the approximate relative molecular mass where PdpA is found. Hence, we also introduced a genetic lesion that diminishes the amount of O-antigen produced in *F. novicida* into the  $\Delta pdpA$  mutant and the  $\Delta pdpA/SKX::pdpA$  complemented strains. Immunoblot analysis of the resulting O-antigen-defective strains (Figure 10b) showed that PdpA is not made in the  $\Delta pdpA$  strain but is made in the wild-type and the complemented strain (both with O-antigen mutations). These results also show that the reduction in the amount of O-antigen results in PdpA migrating as a sharper band. In order to ascertain if the  $\Delta pdpA$  lesion affected expression of genes downstream of *pdpA*, we assessed the expression levels of PdpB, which is encoded by the cistron immediately downstream of *pdpA*. As Figure 10(b) shows, the level of PdpB was essentially identical in the wild-type, the  $\Delta pdpA$  and the  $\Delta pdpA/SKX::pdpA$  strains. We also assessed the expression of PdpA and PdpB in  $\Delta pdpA$  and  $\Delta pdpA/SKX::pdpA$  strains that had the wild-type form of the O-antigen and found essentially identical results as in Figure 10(b) except that the PdpA band was usually distorted (data not shown). Unlike the markerless *pdpA* mutant constructed in this study, the *pdpA::Em<sup>R</sup>* allelic replacement mutant, NZ9, demonstrated marked polarity effects on PdpB (Figure 10c).

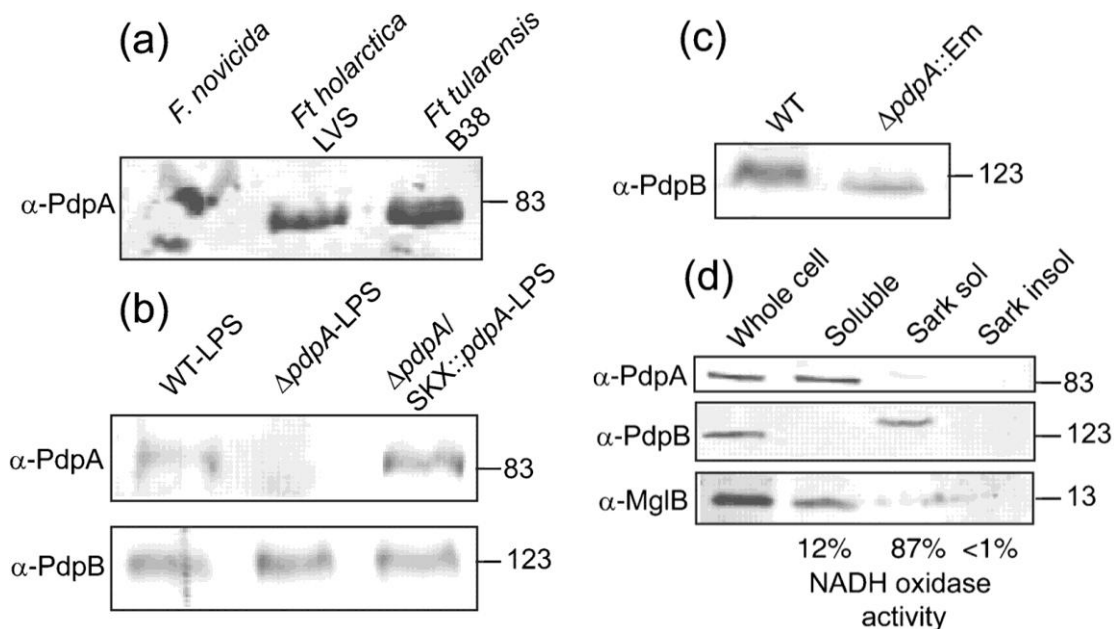

**Figure 10. Detection and subcellular localization of PdpA in *Francisella*.** (a)

Reactivity of anti-PdpA monoclonal antibody with cell extracts of *F. novicida* and two *F. tularensis* subspecies. The O-antigen in *F. novicida* is thought to cause aberrant migration of PdpA. The migration of an 83 kDa molecular mass marker is shown on the right. (b) Effect of deletion of *pdpA* and mutation of O-antigen gene. An O-antigen mutation from the previously described mutant SC92 ('WT-LPS') was transferred to the  $\Delta pdpA$  mutant and the complemented strain  $\Delta pdpA/SKX::pdpA$ , and Western blots with anti-PdpA and anti-PdpB monoclonal antibodies are shown. For the top part of (b) the number at the right indicates actual migration of a molecular mass marker, and for the bottom part, the number indicates a calculated relative molecular mass. (c) A Western blot using anti-PdpB antibody shows that the *pdpA::Em<sup>R</sup>* gene replacement mutant NZ9 expresses greatly reduced levels of PdpB compared to wild-type. (d) Bacteria isolated from a J774A.1 macrophage infection were fractionated to separate soluble and membrane-associated proteins. PdpA was found to localize with the soluble proteins, as

was the transcriptional regulator MglB. PdpB localized to the Sarkosyl-soluble protein fraction, indicating its association with the inner membrane of *F. novicida*. NADH oxidase activity was determined in each fraction as a measure of the relative amount of inner-membrane protein. The number to the right of the top panel of (d) represents the actual migration of the molecular mass marker, whereas the numbers in the two bottom panels represent calculated relative molecular masses. The amount of sample loaded in each lane was normalized by protein content. Results are representative of duplicate experiments.

### 2.3.2 Solubility of PdpA

Some of the genes in the FPI encode homologues of components of T6SSs, and have been shown to be membrane associated. To test the possible role of PdpA as a membrane-bound component of a possible T6SS, we analysed the localization of PdpA in *F. novicida* cells that had infected macrophages. We reasoned that the localization of PdpA during an infection would provide information that might suggest a function. The data presented in Figure 10(d) show that PdpA localizes to the soluble bacterial fraction, and co-localizes with the gene regulatory protein MglB. We had previously shown that PdpB localizes to the inner membrane in broth-grown cells (221), and it localized to the same fraction in macrophage-grown cells (Figure 10d). Outer-membrane proteins Tul4 and FopA were only detected in the Sarkosyl-insoluble fraction using anti-*F. novicida* antibody (data not shown). Similar results were obtained when we analysed the localization of PdpA in broth-grown *F. novicida* (data not shown), with the majority of PdpA localizing to the soluble fraction.

We previously showed that inactivation of FPI genes *iglA*, *dotU* and *pdpB*, which are homologues of canonical components of T6SSs, abolished transport of IgIC to the outer

membrane (221). We found that IglC transport in the  $\Delta pdpA$  background was unaffected (discussed in chapter 4), suggesting that PdpA does not play a role in T6SS-mediated secretion. However, these results should be regarded cautiously, since we have so little information about possible T6SS-mediated secretion in general, and especially in *Francisella*. Attempts to detect PdpA in the macrophage cytosol were unproductive (discussed in chapter 4).

### 2.3.3 PdpA levels affected by *mgLAB* background and iron concentration

Previous work has shown that FPI mRNA expression is depressed when MglA is absent and is increased by low iron concentration (51, 70, 109, 210), but none of these studies examined protein expression levels. In order to assess the effect of these factors on PdpA protein expression, we examined protein production by immunoblot analysis. The expression of PdpA was much reduced in both *mgIA* (GB2) and *mgIB* (GB6) genetic backgrounds as compared to expression in the wild-type strain of *F. novicida* (Figure 11a). A similar effect was seen on the expression of PdpB and IglB in the *mgIA* and *mgIB* backgrounds (Figure 11a). Addition of the chelator Desferal to cultures of *F. novicida* resulted in an increase in PdpA expression in *F. novicida* (Figure 11b), presumably due to the reduction in the amount of available iron. IglB, IglC and PdpB expression responded to the addition of Desferal essentially the same as did PdpA (Figure 11b). The effect of the chelator on protein expression was reversed by the addition of 1 mM FeSO<sub>4</sub>, which resulted in PdpA, PdpB, IglB and IglC levels that were below those found in untreated cultures (Figure 11b). Expression levels of a cross-reactive control protein remained constant regardless of the addition of chelator or excess iron. The levels of PdpB, IglB

and IglC in the  $\Delta pdpA$  strain responded essentially identically to chelator or iron conditions as in the wild-type *F. novicida* strain (data not shown).

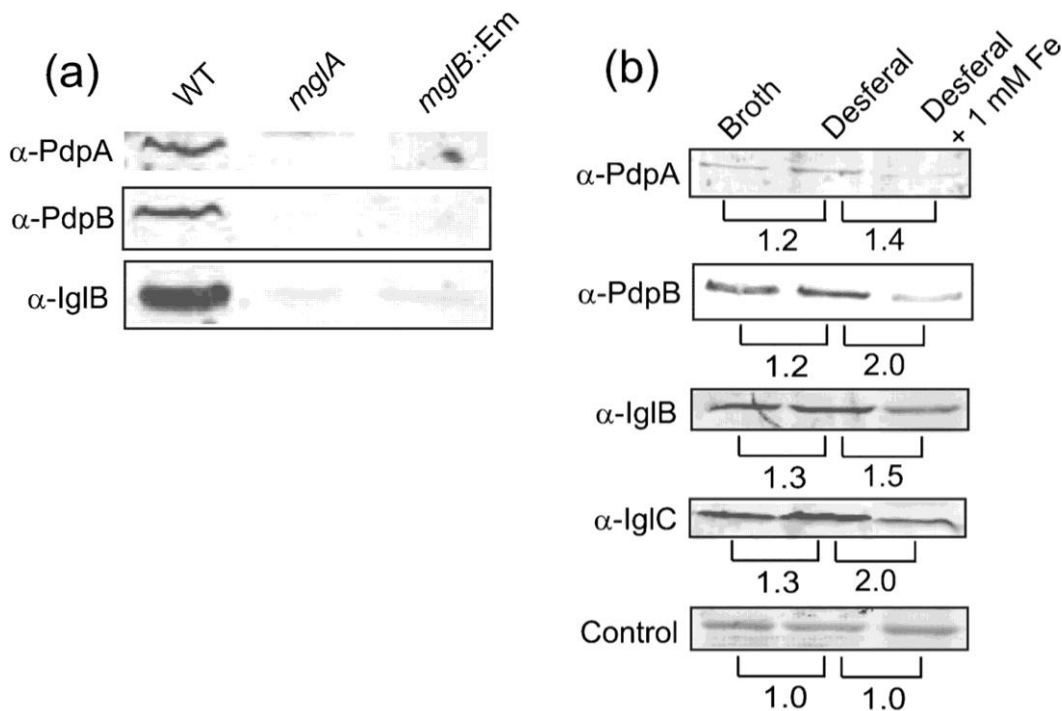
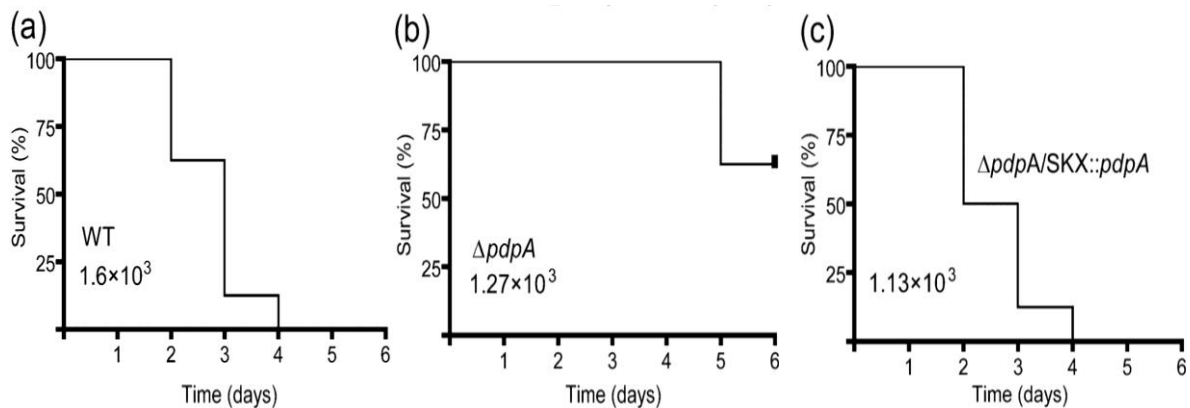

**Figure 11. Regulation of PdpA expression by iron and transcriptional regulators.**

(a) Levels of PdpA, PdpB and IglB protein expression were determined in *mglA* and *mglB* mutant backgrounds. (b) Expression of these proteins, as well as IglC, was also determined in varying iron conditions. The relative level of fluorescence signal generated by reactivity of anti-PdpA, anti-PdpB, anti-IglB, or anti-IglC monoclonal antibodies, calculated as described in Methods, is indicated. The amount of sample loaded to the wells of each polyacrylamide gel was normalized by protein content. The reactivity of a non-specific, cross-reactive protein band is shown in the bottom panel. Results are representative of experiments performed in triplicate.

### 2.3.4 Virulence properties of the $\Delta pdpA$ mutant

Our previous work and the studies of others suggest that PdpA plays a role in virulence. However, these previous studies were unable to measure expression of proteins encoded by genes downstream of *pdpA* or failed to carry out genetic complementation; most studies failed to carry out either of these controls. Hence, we felt it was important to test the virulence of a  $\Delta pdpA$  mutant that lacked translational polarity and could be complemented with a single copy of *pdpA*. We first performed a series of infections with different inoculating doses in chicken embryos and followed these with smaller experimental infections of mice. The data presented in Figure 12 show that, at the inoculating dose of  $10^3$  c.f.u., wild-type *F. novicida* killed 100 % of the chicken embryos by day 4 post-infection. In contrast, the  $\Delta pdpA$  strain failed to kill 50 % of the embryos by 6 days after the start of the infection. Complementation of the  $\Delta pdpA$  mutation with a single copy of wild-type *pdpA* resulted in a strain,  $\Delta pdpA/SKX::pdpA$ , that was equally virulent as the wild-type strain in the chicken embryo infection assay. Similar results were found in mouse infection experiments. Infection with  $10^5$  wild-type *F. novicida* killed 5/5 BALB/cByJ male mice but infection of 10 mice with  $10^7$   $\Delta pdpA$  failed to kill any mice (experiment performed by A. Chou and K. Elkins). As we have shown before (221), infections of chicken embryos with *F. novicida* mutants are largely predictive of the outcome of infection of mice with the same mutants. However, mice appear to be considerably more resistant to killing, especially by attenuated *F. novicida*.



**Figure 12. Attenuation of the  $\Delta pdpA$  mutant in chicken embryos.** Seven-day-old chicken embryos were infected with  $10^3$  c.f.u. of wild-type (WT) (a),  $\Delta pdpA$  (b) and  $\Delta pdpA/SKX::pdpA$  (c) strains of *F. novicida*. Time to death of the embryos was monitored over a period of 6 days. All experiments were done at three separate inoculating doses, and the experiments included at least seven embryos per infective dose per strain; the survival curves presented are representative of three separate trials. The statistical difference between the WT and  $\Delta pdpA$  strain survival curve was measured by the log-rank test and yielded a *P*-value of  $<0.001$ . The *P*-value for a comparison of  $\Delta pdpA$  vs  $\Delta pdpA/SKX::pdpA$  was  $<0.001$ .

## 2.4 Discussion

Recent study of *F. tularensis* has yielded surprisingly little advancement concerning the characterization and function of virulence-associated proteins. Although many virulence factors have been discovered, particularly within the FPI, several of these proteins have proven to be very difficult to study due to toxicity issues and low expression levels. This research represents the first examples of PdpA protein characterization and has investigated the virulence of a non-polar, markerless, in-frame, *pdpA* deletion mutant.

Immediately downstream of *pdpA* lies the *pdpB* gene, and the *pdpB* ribosome-binding site overlaps the 3' end of *pdpA*. This tight translational coupling of *pdpA* and *pdpB*, and between most other adjacent FPI genes, is consistent with mRNA expression studies that indicate that FPI genes are controlled by the same global regulators, including MglA, SspA, PmrA and FevR, or by the same environmental cues, such as low iron concentration (50, 51, 70, 109, 214, 252). Data presented in this work on the effect of MglA and iron concentration on expression of PdpA and other FPI-encoded proteins provide evidence that expression extends to the protein level. The MglB protein has been presumed to be involved in expression, and in this work we provided evidence supporting this idea, as PdpA, PdpB and IglB expression was virtually undetectable in an *mglB* mutant background.

It is also apparent that the allelic replacement of *pdpA* has polar effects on expression of the downstream gene *pdpB*, as there is considerably less PdpB protein present in strain NZ9 ( $\Delta pdpA::Em^R$ ). This polarity may account for the increased attenuation of NZ9 in chicken embryos compared to  $\Delta pdpA$  (data not shown).

One central biological question regarding the FPI-encoded proteins involves their possible role in secretion or as effector proteins that interact with host-cell components. Using macrophage-grown *F. novicida* we found PdpA in the bacterial cytoplasm. Although macrophage-grown *F. novicida* cells are more difficult to analyse than broth-grown cells, we reasoned that they would provide better evidence of the biologically relevant localization of PdpA than analysis of broth-grown *F. novicida*. Localization of PdpA to the bacterial cytoplasm may lead one to believe that the protein is not a component of the T6SS, as most proteins involved in assembling a secretion apparatus

are membrane associated. However, this is not always the case; T6SS proteins have been shown to localize to both membrane and cytoplasmic fractions so our results have to be interpreted carefully (407). As a soluble protein, PdpA may function as a chaperone component of the T6SS or may be a secreted effector protein. We believe that PdpA might be a secreted effector protein as it does not appear to play a role in secretion as defined by our recently described criteria (221), yet its absence profoundly decreases virulence in both chicken embryos and adult mice. Also, the deduced PdpA amino acid sequence shows low-level similarities to fragments of multiple proteins involved in the eukaryotic ubiquitin-proteasome pathway, and such molecular mimicry has been observed in virulence effectors of other intracellular pathogens (19). One of the motifs that we identified is a possible F-box motif in the N-terminal region of PdpA. In eukaryotic cells F-box-containing proteins are involved in protein-protein interactions, most commonly in proteins in the ubiquitin-ligase complex (200). Inspection of the Pfam tree of F-box proteins (PF00646; <http://pfam.sanger.ac.uk/family?acc=PF00646>) reveals several prokaryotic F-box-containing proteins, and F-box regions have been shown to be important in two bacterial plant pathogens (18, 380). Attempts to express domains that showed similarity to those found in ubiquitin-ligase complexes have been unsuccessful due to apparent toxicity involved in expressing PdpA protein domains, particularly those located within the amino terminus of the protein. Although we believe PdpA is a secreted effector protein, the current tools and methodologies available have been unable to confirm this. Clearly, extensive analysis of PdpA will be required to surmise its function in virulence. The next chapter reports studies on the intracellular growth phenotype of the

$\Delta pdpA$  mutant and the effect of the mutation on the macrophage gene expression response to *F. novicida* infection.

### **Chapter 3: A *Francisella novicida pdpA* mutant exhibits limited intracellular replication and remains associated with the lysosomal marker LAMP-1**

(*Microbiology* (2009), **155**, 1498–1504.)

Crystal L. Schmerk,<sup>1</sup> Barry N. Duplantis,<sup>1</sup> Perry L. Howard<sup>1,2</sup> and Francis E. Nano<sup>1</sup>

<sup>1</sup>Department of Biochemistry and Microbiology, University of Victoria, Victoria, BC, Canada

<sup>2</sup>Department of Biology, University of Victoria, Victoria, BC, Canada

#### **3.1 Introduction**

*Francisella tularensis* is a facultative intracellular pathogen that is able to grow in a number of cell types, and is often found in infected tissues within cells of the monocytic cell lineage (20, 45, 96, 122, 166). *In vitro* studies have shown that *F. tularensis* subverts the normal endocytic pathway of host macrophages and grows rapidly within these cells (325). Approximately 20 min after macrophage engulfment, the *Francisella*-containing phagosome acquires the early endosomal markers EEA-1 and Rab5 (87). The phagosome subsequently gains late endosomal markers such as Rab7, CD63, LAMP-1 and LAMP-2 (87, 325). This late endosome-like compartment acquires the proton vacuolar ATPase pump and becomes transiently acidified but does not associate with lysosomal markers, such as cathepsin D (87, 323, 325). *Francisella* is thus able to prevent phagosomal–lysosomal fusion, and within 4 h of uptake actively breaks down the phagosomal membrane in order to escape into the host-cell cytosol and replicate. The infective process eventually leads to host-cell death, whereby the bacteria are freed to infect neighbouring cells.

All *Francisella* species contain at least one copy of a gene cluster known as the *Francisella* pathogenicity island (FPI). A number of genes, particularly within the FPI, have been shown necessary for phagosomal escape and intracellular replication; however,

most of these studies have not investigated the nature of the gene products nor provided any evidence to support a mechanism of action of the gene products (42, 104, 263, 323, 327). Studies of mutants of *Francisella novicida* that have knockouts of genes encoding phosphatases suggest that one or more of them play a role in phagosome membrane degradation. Since the acid phosphatase, AcpA, also has lipase activity, it may play an important role in degrading the membrane (251, 253, 303).

Microarray analysis has recently been employed in a variety of ways to study *Francisella* infection. The majority of these studies have used microarray technology to profile the transcriptional response of *Francisella*-infected immune cells (16, 60, 286). Some have used the microarray-based studies to identify virulence genes (402) or study the control of virulence gene expression by regulators such as *pmrA*, *mglA* and *sspA* (70, 252, 319). Microarray analysis has not hitherto been used to profile the change in host-cell responses to *Francisella* strains with mutations in virulence genes.

The *pdpA* gene is one of the largest in the FPI and is located at the beginning of a putative operon containing the *pdpB*, *vgrG* and *dotU* genes. A previously described gene replacement mutant in the *pdpA* gene of *F. novicida* exhibited impaired intracellular replication and avirulence in mice; however, the substitution of the erythromycin resistance ( $\text{Em}^{\text{R}}$ ) cassette for *pdpA* has since been shown to have polarity effects on genes downstream of *pdpA* (previous chapter). Because many of these downstream genes affect intracellular growth, it is possible that the altered intracellular growth phenotype of the  $\Delta$  *pdpA*:: $\text{Em}^{\text{R}}$  mutant was due to the suppressed expression of multiple FPI-encoded proteins. In the previous chapter we describe a non-polar, *F. novicida*, *pdpA* deletion mutant and show that it is highly attenuated for virulence. In this chapter we examine the

intracellular growth phenotype of the  $\Delta pdpA$  mutant, and the effect of the deletion of *pdpA* on macrophage gene expression response to *F. novicida* infection.

## **3.2 Materials and Methods**

### **3.2.1 Bacterial strains and growth conditions**

The bacterial strains used in this study are listed in Table 2. *F. novicida* strains were grown using trypticase soy agar or broth supplemented with 0.1 % (w/v) cysteine (TSAC, TSBC). When necessary, 15  $\mu\text{g}$  kanamycin  $\text{ml}^{-1}$  was added to the growth medium.

### **3.2.2 Intracellular growth assays**

Bone marrow cells were isolated from the femurs of male BALB/c mice and seeded in 96-well cell culture plates at a density of  $3 \times 10^5$  cells per well. Cells were incubated for 1 week in complete Dulbecco's Modified Eagle Medium (cDMEM) supplemented with 10 % fetal bovine serum, 2 mM L-glutamine, 1 % MEM nonessential amino acids, 10 mM HEPES buffer solution and 10 % conditioned L929 cell supernatant. After 7 days the macrophages were infected with *F. novicida* strains at an m.o.i. of 50:1 (bacteria: macrophage). The monolayers were incubated at 37 °C, 5 % CO<sub>2</sub> for 1 h to allow uptake of the bacteria and then washed five times using sterile PBS. Infected macrophages were lysed with 0.1 % (w/v) deoxycholic acid at 0, 24 and 48 h post-infection. Lysates were serially diluted in PBS containing 0.1 % (w/v) gelatin and plated on TSAC for enumeration. Experiments using the J774A.1 murine macrophage cell line were carried out in a manner similar to those used for bone marrow-derived macrophages (BMDM).

Cells were seeded in 96-well cell culture plates at a density of  $5 \times 10^4$  cells per well and allowed to adhere overnight. *F. novicida* strains were added to the wells at an m.o.i. of 50:1 and the infection was carried out as described above. Infected macrophages were lysed with 0.1 % deoxycholic acid at 0, 24 and 48 h post-infection.

### **3.2.3 Real-time PCR assays**

J774A.1 murine macrophage infections were performed as described above, except that infections were performed in 25 cm<sup>2</sup> tissue culture flasks. mRNA was isolated from the macrophage cell line 12 h after infection using PureLink Micro-to-Midi total RNA purification system (Invitrogen) according to the manufacturer's protocols. Quantitative real-time (qRT-PCR) data were generated using the RT<sup>2</sup> Profiler PCR array mouse Signal Transduction PathwayFinder (SuperArray Bioscience). qRT-PCR was performed with 1.5 µg total RNA according to the manufacturer's protocol using the Stratagene MX4000 thermocycler.

### **3.2.4 Immunofluorescence and LAMP-1 association**

J774A.1 macrophages were seeded on 22 mm glass coverslips in 6-well tissue culture plates at a density of  $1 \times 10^6$  cells per well and allowed to adhere overnight. Cells were chilled on ice for 5 min and bacteria were added to each well at an m.o.i. of 500:1, after which the cells were chilled for an additional 10 min. Cells were immediately warmed in a 37 °C water bath for 3 min to synchronize bacterial uptake and then incubated at 37 °C, 5 % CO<sub>2</sub> for an additional 20 min. Wells were washed five times in PBS and fresh medium was added. At the appropriate time points the coverslips were removed and rinsed in PBS. The coverslips were then treated with 2 % (w/v)

paraformaldehyde, 1 % (w/v) sucrose, PBS for 20 min at room temperature followed by immersion in ice-cold methanol for 10 min at  $-20^{\circ}\text{C}$ . Coverslips were placed in blocking solution containing 5 % lamb serum for 30 min. Rabbit polyclonal anti-*F. novicida* (261) and rat monoclonal anti-LAMP-1 (DSHB, University of Iowa) antibodies were incubated with the coverslips overnight at  $4^{\circ}\text{C}$  at a dilution of 1:1000. Coverslips were then washed three times with PBS and incubated for 2 h with goat anti-rabbit Alexafluor568 and goat anti-rat Alexafluor488 secondary antibodies (Molecular Probes) at a dilution of 1:1500. The coverslips were incubated for 5 min with Hoescht 33258 (Molecular Probes) to label the DNA. Cells were imaged with a Leica DMIREZ inverted fluorescent microscope using a 100x oil immersion lens. Using Openlab 5.1 software, multiple-channel Z stacks were captured and deconvoluted in order to score macrophage LAMP-1 association with the bacterial strains.

### **3.2.5 Graphing and statistics**

The Prism GraphPad v4.03 software was used to generate graphs and to calculate the appropriate statistical values, including standard deviation, standard error of the mean and *P*-values. For *P*-values the Student *t*-test or two-way ANOVA were used where appropriate.

**Table 2. Bacterial strains used to study the intracellular growth phenotype of the *pdpA* mutant and host cell signalling pathways altered by infection with *F. novicida*.**

Strain	Characteristics	Reference
U112	Wild-type <i>F. novicida</i>	ATCC 15482
JLO	U112 with deletion in FTN_1390, where SKX vector inserts; identical growth and virulence with respect to U112	(222)
GB2	U112 with point mutation in global virulence regulator, <i>mglA</i>	(30)
$\Delta pdpA$	JLO with a deletion of <i>pdpA</i>	This study
$\Delta pdpA/SKX::pdpA$	$\Delta pdpA$ complemented with the integrating pJL-SKX:: <i>pdpA</i> construct	This study
$\Delta iglC$	JLO with a deletion of <i>iglC</i>	(104)

### 3.3 Results

#### 3.3.1 Intracellular growth of *pdpA* mutants

Our previous work had shown that a gene replacement mutation in *pdpA* resulted in a strain defective for intramacrophage growth (263). We have since learned that this and other replacement mutations generated polarity effects; hence we examined the phenotype of the newly created  $\Delta pdpA$  strain (discussed in the previous chapter), which has a non-polar deletion mutation. Infection of the  $\Delta pdpA$  mutant in mouse BMDM resulted in limited growth that showed an initial increase in *F. novicida* numbers followed by a decline in numbers (Figure 13a). Macrophages infected with the  $\Delta pdpA$  mutant appeared healthy throughout the infection, displaying no signs of cytotoxicity or cell-rounding. Genetic complementation, but not a mock complementation (data not shown) with the pJL-SKX vector, restored nearly complete growth in the macrophages (Figure 13a). Very

similar results were observed when J774A.1 macrophages were infected with the  $\Delta pdpA$  mutant and its genetic complement (Figure 13b). While statistical analysis showed that the growth of the  $\Delta pdpA$  mutant is clearly different from both the wild-type strain and from the complemented strain, this analysis also showed that the growth of the wild-type and complemented strains was different, indicating that the wild-type phenotype was not fully restored by genetic complementation. The influence of an exogenous promoter in the pJL-SKX::*pdpA* vector may account for these differences.

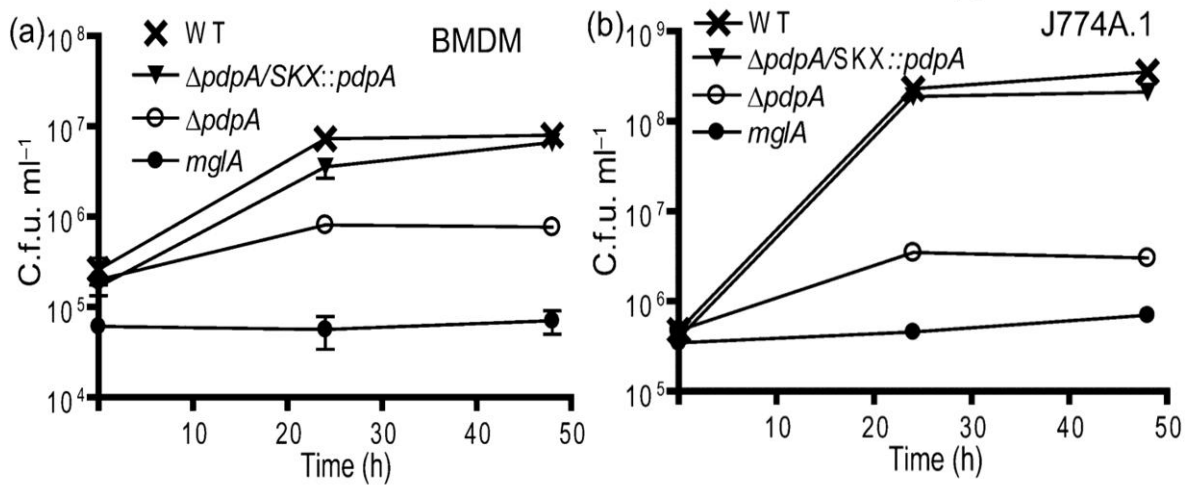
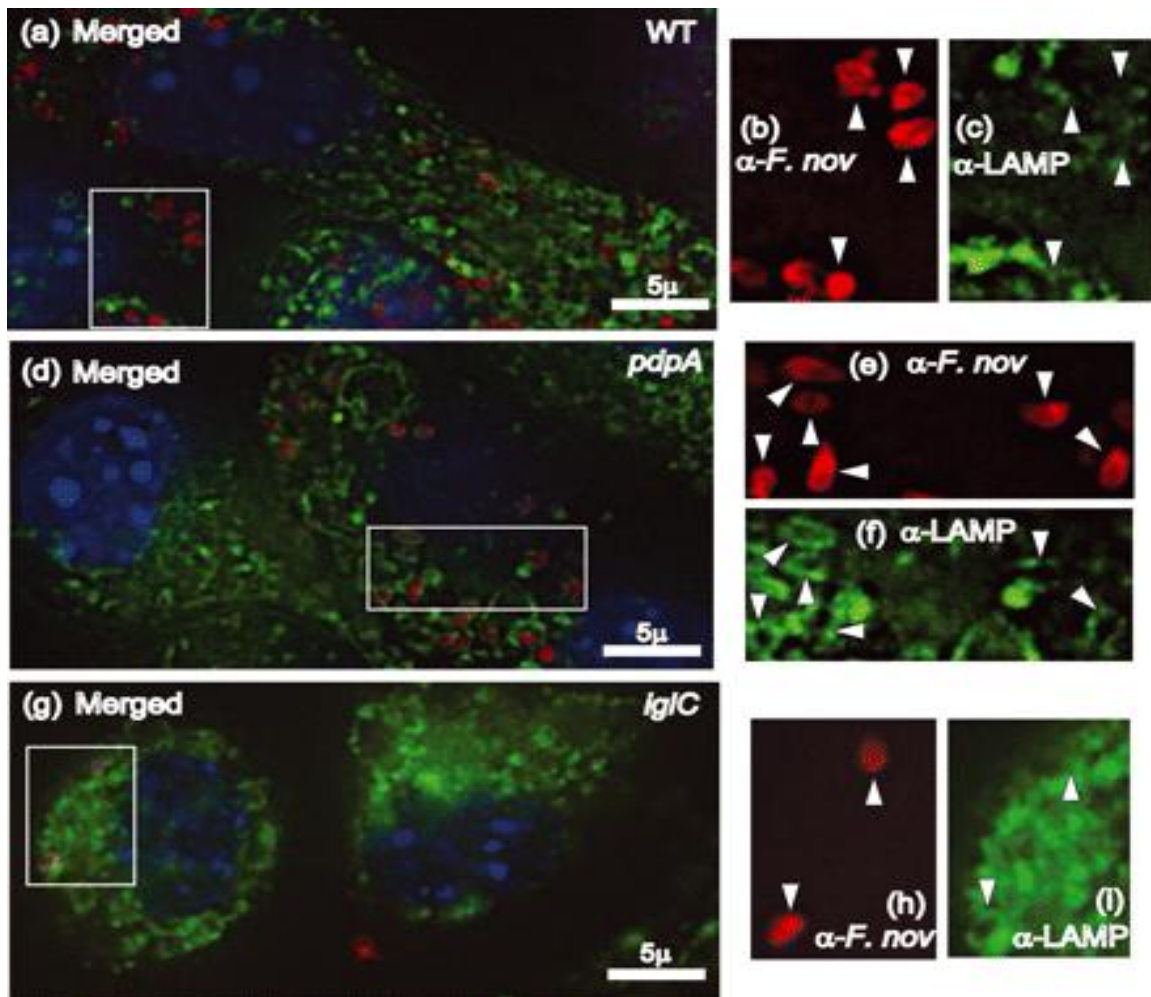

**Figure 13. Intracellular growth of  $\Delta pdpA$  mutants.** The  $\Delta pdpA$  mutant was able to replicate in BMDM (a) and J774A.1 cells (b) within the first 24 h of infection. Bacterial numbers decreased after 48 h and macrophages exhibited no signs of cytotoxicity. Complementation of the  $\Delta pdpA$  deletion restored the wild-type (WT) growth phenotype. The  $\Delta mglA$  mutant was included as a control as it is unable to replicate within macrophages. All data points in both panels are representative of three replicates and each experiment was performed in triplicate. Two-way ANOVA was used to calculate the significance of the differences in the growth curves between pairs of strains. For BMDM: WT vs  $\Delta pdpA$ ,  $P < 0.001$ ; WT vs  $\Delta pdpA/SKX::pdpA$ ,  $P = 0.0261$ ; and for  $\Delta pdpA$  vs  $\Delta pdpA/SKX::pdpA$ ,  $P = 0.0028$ . For J774A.1 macrophages: WT vs  $\Delta pdpA$ ,  $P < 0.001$ ; WT vs  $\Delta pdpA/SKX::pdpA$ ,  $P = 0.006$ ; and for  $\Delta pdpA$  vs  $\Delta pdpA/SKX::pdpA$ ,  $P < 0.001$ .

### 3.3.2 LAMP-1 association of the *pdpA* mutant

There is now a substantial body of literature that documents the escape of *Francisella* from LAMP-1-laden phagosomal vesicles, and the failure of some FPI mutants to escape at wild-type levels. In order to evaluate the intracellular trafficking of the  $\Delta pdpA$  mutant, we infected mouse macrophage-like cell line J774A.1 cells, and

examined the co-localization of LAMP-1 with wild-type *F. novicida*, the  $\Delta pdpA$  mutant, and a  $\Delta iglC$  mutant. *F. tularensis* and *F. novicida* mutants in *iglC* have been shown by others to be defective for phagosome escape (42, 218, 327). Our experimental results using deconvoluting fluorescence microscopy showed a clear separation of wild-type *F. novicida* and LAMP-1 localization at 12 h post-infection (Figure 14a–c). In contrast, the  $\Delta pdpA$  mutant (Figure 14d–f) and the  $\Delta iglC$  mutant (Figure 14g–i) showed close association of *F. novicida* and LAMP-1 localization. A close examination of the micrographs revealed that individual cells of  $\Delta pdpA$  (Figure 14d–f) and  $\Delta iglC$  (Figure 14g–i) were surrounded by a LAMP-1-laden structure that took the shape of the bacterial cells. However, this was not seen in the images of wild-type *F. novicida* (Figure 14a–c). Genetic complementation with pJL-SKX : : *pdpA* restored LAMP-1 association to wild-type levels (data not shown). The clear association of  $\Delta pdpA$  cells within a LAMP-1-loaded structure continued even after 19 h infection (Figure 15a–c). A quantitative analysis of *F. novicida*-LAMP-1 association showed that less than 10 % of the wild-type *F. novicida* was LAMP-1 associated 12 h post-infection while 92 % of  $\Delta pdpA$  and 74 % of the  $\Delta iglC$  strain were LAMP-1 associated (Figure 16).



**Figure 14. The  $\Delta pdpA$  mutant replicates in macrophages but remains LAMP-1 associated.** J774A.1 macrophages adhered to glass coverslips were infected with *F. novicida* U112 (a–c),  $\Delta pdpA$  (d–f), or  $\Delta iglC$  (g–i) at an m.o.i. of 500:1. The colours in merged panels a, d and g correspond to Hoechst DNA (blue), anti-LAMP-1 (green), and anti-*F. novicida* (red). Panels b, e and h represent staining with anti-*F. novicida* antibody, and panels c, f and i represent staining with anti-LAMP-1. The arrowheads indicate areas of LAMP-1 staining that correspond to bacterial location.

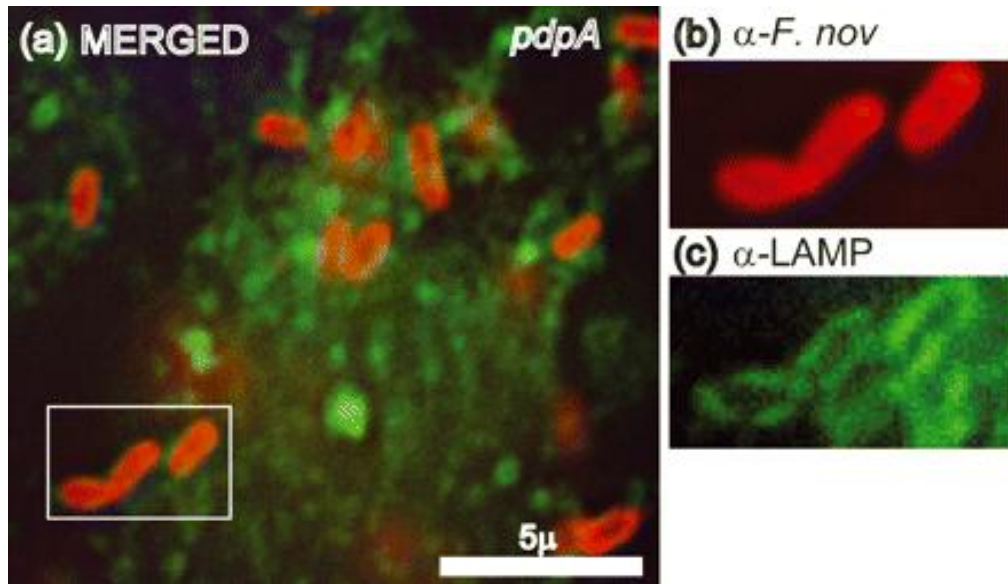

**Figure 15. The  $\Delta pdpA$  mutant remains LAMP-1 associated late in infection.** The association of  $\Delta pdpA$  with LAMP-1 continues after 19 h infection (a). This localization is clearly seen in the corresponding enlarged images of the boxed region stained with only anti-*F. novicida* (b) or anti-LAMP-1 (c).

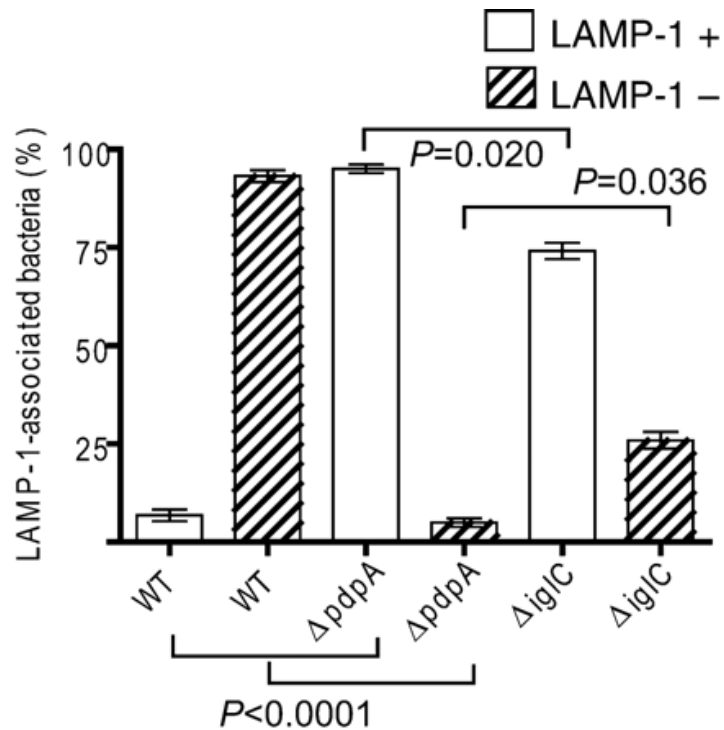

**Figure 16. Association of *F. novicida* mutants with LAMP-1.** Bacterial association with LAMP-1 was scored at 12 h post-infection by counting a minimum of 100 *F. novicida* cells for each strain. The Student's *t*-test was used to examine the significance of the differences between strains of the LAMP-1 positive or negative *F. novicida* cells and some of these *P*-values are shown on the graph. The *P*-values for wild-type (WT) *F. novicida* vs the  $\Delta iglC$  strain are (LAMP-1 positive), 0.0001; and (LAMP-1 negative), 0.0024. The experiment was performed in triplicate.

### 3.3.3 Effect of the deletion of *pdpA* on host-cell mRNA responses

As an approach to discern a possible role of PpdA in host-cell processes, we compared the effect of infection of macrophages with wild-type and the  $\Delta pdpA$  deletion strain on host-cell mRNA levels of selected signalling pathways. A summary from a representative set of experiments of the mRNA levels that were affected is shown in Table 3. Each of the columns showing the fold changes represents the results of separate

experiments in which the mRNA levels were measured from sets of macrophage cultures subjected to two different infections or an infection and a mock infection. In addition, all experimental runs were duplicated. When the mRNA levels following infection with the  $\Delta pdpA$  strain are compared to those following infection with the wild-type strain there are 28 mRNA species that are elevated and four that are depressed (Table 3, column 3) at least twofold. Importantly, the experimental fold differences seen for infections with the  $\Delta pdpA$  vs the wild-type strain (column 3) are reflected by a comparison between the results of a wild-type infection vs uninfected macrophages (column 5) and the results of the mRNA levels measured in  $\Delta pdpA$  infections vs uninfected macrophages (column 7). Of the 32 RNAs shown in Table 3, thirteen encode ligands, five encode receptors, six encode pathway components and eight encode effector molecules. Of the ten most strongly upregulated messages, eight are transcripts from ligand-encoding genes.

**Table 3. Changes in mRNA levels of J744 macrophage-like cells following infection with *F. novicida* strains**

mRNA	Corresponding protein	$\Delta pdpA$ infection vs wild-type infection		Wild-type infection vs uninfected J774A.1		$\Delta pdpA$ infection vs uninfected J774A.1	
		Fold change	<i>P</i> -value	Fold change	<i>P</i> -value	Fold change	<i>P</i> -value
Lep	Leptin	454	<0.001	0.41	0.282	184.82	<0.001
Igfbp3	Insulin-like growth factor-binding protein 3	387	<0.001	2.03	0.142	786.88	0.001
Wnt1	Wingless-related MMTV integration site 1	305	<0.001	0.57	0.607	174.37	<0.001
Ccl20	Chemokine (C-C) ligand 20	303	<0.001	1.47	0.285	446.34	<0.001

Wnt2	Wingless-related MMTV integration site 1	191	<0.001	1.65	0.397	315.17	<0.001
Birc1a	Baclovril I AP repeat-containing 1	115	<0.001	2.79	0.213	82.25	0.0167
Csf2	Colony stimulating factor 2	110	<0.001	5.91	0.033	648.07	<0.001
Fgf4	Fibroblast growth factor 4	82	0.014	1.30	0.702	105.86	0.0095
Lef1	Lymphoid enhancer binding factor1	76	<0.001	1	N/A	75.90	<0.001
Cyp19a1	Cytochrome P450, family 19, subfamily a, polypeptide 1	68	0.02	1.86	0.334	126.06	0.0084
Sele	Selectin, endothelial cell	50	<0.001	1.48	0.580	74.54	<0.001
Tmepai	Transmembrane, prostate androgen-induced RNA	45	0.04	2.9	0.215	131.23	0.007
Hhip	Hedgehog-interacting protein	21	<0.001	4.21	0.033	86.70	<0.001
Wisp1	WNT inducible pathway protein 1	8.8*	0.001*	6.06*	0.011*	19.62	0.0348
Hk2	Hexokinase	0.11	<0.001	1.01	0.9817	0.12	0.0015
Fasl	Fas (TNF super family receptor)	8.5	0.08	0.7	0.767	5.91	0.0092
Cxcl1	Chemokine (C-x-C) ligand 1	7.5	<0.001	1.62	0.341	12.18	0.002
Igfbp4	Insulin-like growth factor-binding protein 4	6.8	0.004	0.08*	0.0013*	0.56*	0.058*
Lta	Lymphotoxin A	6.3	<0.001	0.81	0.489	5.11*	<0.001*
Il2ra	Interleukin 2 receptor $\alpha$	6.1	0.002	0.72	0.613	4.40*	0.044*
Il1a	Interleukin 1 $\alpha$	4.9	0.035	2.73	0.0211	13.38	0.001
Ccnd1	Cyclin D1	3.7	<0.001	0.28	0.002	1.02*	0.093*
Mdm2	Transformed mouse 3T3 cell	0.3	0.002	3.22	0.0088	0.97	0.901

Tert	double minute 2 Telomerase reverse transcriptase	3.3	<0.001	0.58*	0.053*	1.92	0.008
Trp53	Transformation- related protein 53	3.2	<0.001	0.54	0.019	1.72	0.021
Nos2	Nitric oxide synthase 2 inducible, macrophage	0.31	0.002	11.3*	<0.001*	3.49*	0.004*
Ikbkb	Inhibitor of kappaB kinase $\beta$	2.8	0.004	0.79*	0.252*	2.24*	0.009*
FasN	Fatty acid synthase	0.38	0.16	0.23	0.028	0.09	0.001
Il4ra	Interleukin 4 receptor $\alpha$	2.54	0.002	0.52*	0.026*	1.32*	0.22*
Tfrc	Transferrin receptor	2.4	<0.001	0.82*	0.047*	19.3*	0.026*
Nab2	Ngfi-A-binding protein	2.3	<0.001	0.81*	1.38*	1.85*	0.001*
Cdk2	Cyclin- dependent kinase 2	2.1	<0.001	0.45*	0.001	0.98	0.877

\*Indicates that a value represents the mean of four samples rather than five in an experimental run.

Experimental results presented in Table 3 contributed by B. N. Duplantis.

### 3.4 Discussion

Like many intracellular pathogens, the ability of *F. tularensis* to interfere with the endocytic pathway of its host cell is vital in the pathogen's ability to cause disease.

Although it is clear that infecting bacteria are able to break down the phagocytic membrane prior to lysosomal fusion, it is not clear what virulence factors are responsible for this process. It is apparent that many of the FPI-encoded proteins are required for *Francisella* intracellular growth and virulence, although some of the pathogenicity island proteins are required only for the latter (221). There is also substantial bioinformatic and biochemical evidence that the FPI encodes proteins that make up a type VI secretion apparatus or a macromolecular structure related to the type VI secretion system (37, 104, 221). Although we and others have adopted the hypothesis that an FPI-encoded secretion system is responsible for transport of virulence factors that modulate host-cell functions, there is, at present, little evidence for this model, and no experimental results that precisely define the role of any FPI-encoded protein.

This study represents the first detailed analysis of a non-polar *pdpA* deletion mutant and the role of PdpA in intracellular growth. Although the  $\Delta pdpA$  mutant is able to replicate, albeit minimally, in both BMDM and J774A.1 macrophages, this replication ceases after 24 h and bacterial burdens begin to decrease. This growth phenotype differs from that of a previously studied polar allelic replacement mutant that was completely impaired in its ability to replicate within macrophages (263). Recent work by Chong *et al.* reveals that polarity effects are also observed in the  $\Delta iglC::Em$  mutant, with levels of IglD expression being drastically reduced in this strain (76). These authors suggest that such observations require the re-evaluation of conclusions drawn from previous studies

using the  $\Delta iglC::Em$  mutant. This agrees with our findings regarding the  $\Delta pdpA::Em$  mutant and emphasizes the importance of creating non-polar mutants for analysis, especially in the FPI, where the full expression of several transcriptionally linked genes appears to be required for intracellular growth. Statistical analysis indicated that genetic complementation of the *pdpA* deletion did not fully restore intracellular growth to wild-type levels. The incomplete complementation may have resulted from the recombinant *pdpA* gene being located at an ectopic location within the chromosome, leading to subtle alterations in *pdpA* expression.

Other researchers have shown that mutation of some FPI genes leads to *Francisella* strains that fail to escape the phagosome (42, 218, 327). Like this work, these studies are attempts to surmise the function of different FPI-encoded proteins by examining the intramacrophage phenotype of *Francisella* strains with lesions in FPI genes. The deletion mutant of *pdpA* made in this work behaves similarly to mutants in *iglC* and *igLD*, in that all the mutants are impaired in their intracellular replication and have an increased association with the LAMP-1 lysosomal marker at time points when wild-type *Francisella* has escaped the phagosome (42). Since the FPI appears to encode a T6SS, the current challenge is to decipher which FPI genes are needed for secretion and which, if any, encode secreted effector proteins that interact with host-cell components. We do not believe that PdpA is a structural component of the T6SS because the protein does not seem to play a part in the secretion of IglC (discussed further in next chapter) (221), and bioinformatic analysis fails to show any similarity of PdpA with known T6SS components in other bacteria.

Without knowing the nature of PdpA, and whether its mode of action has a direct or indirect effect on host-cell function, it is difficult to attribute a biological response directly to its expression. Nevertheless, our comparison of host-cell mRNA responses to infection by wild-type *F. novicida* and to the  $\Delta pdpA$  mutant may contribute to the development of hypotheses about the role of PdpA and its interaction with host-cell components. Our examination of the levels of selected host-cell transcripts shows that the absence of PdpA in *F. novicida* results in significantly different host-cell responses to infection compared to an infection with wild-type *F. novicida*. That the absence of PdpA results in higher levels of mRNA for genes encoding ligands suggests that one of PdpA's functions is to suppress macrophage ability to signal via growth factors, cytokines and adhesion ligands. Our inference from these limited data is that PdpA plays a role in suppressing the infected macrophage's ability to recruit and stimulate other immune cells. It is still unclear whether these effects on host cell signalling are a direct or indirect result of PdpA's absence. Thus, these results can only be considered as clues to the role of PdpA in the intracellular parasitism by *F. novicida*, and considerably more work is needed to define the role and mode of action of PdpA.

## Chapter 4: Efforts in determining the function of PdpA (unpublished data)

### 4.1 Introduction

Intracellular pathogens have developed many strategies to avoid host cell defenses and cause disease. One tactic employed by pathogens is to mimic host cell proteins in order to interfere with normal host processes or hijack these host processes for their own means (113, 353). The *Agrobacterium tumefaciens* protein VirF contains an F-box domain (336, 380). In eukaryotes this conserved domain is approximately 45 amino acids in length and is found at the amino terminus of F-box proteins. The F-box domain mediates interaction with Skp1, a component of the SCF ubiquitin ligase complex (200). This complex is one of several E3 ubiquitin ligases which are responsible for labelling proteins with ubiquitin. The resulting ubiquitination results in either the activation of a range of signalling cascades or degradation of the target protein via the 26S proteasome (19, 315). The carboxy terminus of F-box proteins contains a domain which interacts with proteins which are targets for ubiquitination via the SCF complex (200). VirF of the plant pathogen *A. tumefaciens* mimics eukaryotic F-box proteins and is able to interact with plant homologues of the yeast Skp1 protein (336). The VirF-containing SCF complex is responsible for the targeted degradation of *Agrobacterium* proteins VirE2 and VIP1 when they are no longer required by the pathogen (380). There are many proteins encoded within sequenced bacterial genomes that are predicted to contain F-box domains; however few of these predicted proteins have been studied (18, 336).

Intracellular pathogens secrete a variety of effector proteins into the host cell environment. Several of these secreted effectors have been shown to play important roles

in modulating a variety of host cell responses including the prevention of NF $\kappa$ B activation and the alteration of phagosome maturation or stability (19, 128, 315, 340). Numerous bacterial effector proteins including, YopJ and OspG, specifically interfere with host cell ubiquitin-proteasome related pathways (198, 258, 416). Ubiquitination plays an important role in regulating membrane protein trafficking and is involved in endosomal maturation and signalling (5, 43, 177). Surprisingly little is known about the role of ubiquitination in phagosomal maturation and signalling. Work by Lee *et al.* suggests that ubiquitination and a functional proteasome are required for receptor elimination from phagosome membranes but they do not appear to play a role in phagosomal fusion events (212). To date, no bacterial protein has been found to prevent phagosomal maturation or disrupt the integrity of the phagosome by interfering with ubiquitin related pathways.

*Francisella tularensis* is a facultative intracellular pathogen whose disease mechanisms are poorly understood. The *Francisella* pathogenicity island was discovered in 2004 and contains many genes which are required for the intracellular growth and virulence of the bacterium (262, 263). Several proteins within the FPI, including IglA,B,C, PdpB and DotU, have been recognized as components of a recently identified type VI secretion system (104, 221). Further research is needed to identify all of the proteins involved in this secretion system, including which proteins are the effectors transported by this secretion apparatus. As discussed in the previous chapters, the PdpA protein is encoded for within the FPI and is needed for *F. tularensis* to cause disease. An in depth analysis discussed in chapter 3 revealed that a  $\Delta$ *pdpA* mutant remains LAMP-1 associated during macrophage infections, indicating that the mutant is unable to escape

the phagosome and replicate within the host cell cytosol. In this chapter we further study the function of PdpA through targeted mutagenesis, immunofluorescence microscopy and *Francisella* secretion assays.

## 4.2 Materials and Methods

### 4.2.1 Bacterial strains and growth conditions

The bacterial strains used in this study are listed in Table 4. *F. novicida* strains were grown using trypticase soy agar or broth supplemented with 0.1 % (w/v) cysteine. When necessary, 15  $\mu\text{g}$  kanamycin  $\text{ml}^{-1}$  was added to the growth medium.

### 4.2.2 Mutagenesis and complementation

The *pdpA*  $\Delta 112-227$  mutant strain was created using the technique described in chapter 2. The *pdpA*  $\Delta 112-227$  mutant was complemented with a full length *pdpA* gene using the kanamycin integration vector pJL-SKX which was also described in section 2.2.2. The alanine mutants were created using a megaprimer based mutagenesis approach as described by Tyagi and Duggleby (379). Primers were designed which would change specific amino acids within PdpA, replacing them with alanine residues (see figure 15). The alanine mutant amplicons were cloned into pWSK29 to create pWSK29::*pdpA*<sub>S121S122 $\rightarrow$ A121A122</sub>, pWSK29::*pdpA*<sub>L127L139 $\rightarrow$ A127A139</sub>, and pWSK29::*pdpA*<sub>K162R164 $\rightarrow$ A162A164</sub>. The inserts were excised using *XhoI*, ligated to the *XhoI-XhoI sacB-Em<sup>R</sup>* cassette from pJL-ES-X, and the ligation reaction was used to transform *F. novicida* JL0 as described in section 2.2.2. The sequences of the primers used to create these genetic constructs will be made available upon request.

### 4.2.3 Expression of FLAG-epitope tagged FPI proteins in *F. novicida*

The *pdpA* and *pdpE* genes were PCR amplified and ligated into pKH3, a pFNTLP derivative with a 3X FLAG insert (Hueffer *et al.*, unpublished data). Constructs were transformed into *F. novicida* U112 and strains were analyzed by Western immunoblotting for production of FLAG-tagged proteins of the expected size.

### 4.2.4 Intracellular growth assays

Bone marrow derived macrophages and J774A.1 macrophages were infected as described in section 3.2.2. NIH 3T3 fibroblasts were infected in a similar manner to the macrophage infections. Cells were seeded in 24-well cell culture plates at a density of  $5 \times 10^4$  cells per well and allowed to adhere overnight. *F. novicida* strains were added to the wells at an m.o.i. of 500:1 and the infection was carried out as described above. Infected fibroblasts were lysed with 0.1 % deoxycholic acid at 0, 24 and 48 h post-infection.

### 4.2.5 Chicken embryo infections

Fertilized White Leghorn chicken embryos were infected with the appropriate *F. novicida* strains as described in section 2.2.6. After infection, embryo death was monitored over a period of 6 days; the results of one inoculating dose are presented.

#### 4.2.6 NIH 3T3 fibroblast immunofluorescence

NIH 3T3 fibroblasts were seeded on 22 mm glass coverslips in 6-well tissue culture plates at a density of  $6 \times 10^5$  cells per well and allowed to adhere overnight. The infection was carried out as described in section 3.2.4 with the exception that bacteria were added to each well at an m.o.i. of 1000:1. The coverslips were then fixed and prepared for immunofluorescence imaging as described in section 3.2.4.

#### 4.2.7 Ubiquitin localization immunofluorescence

J774A.1 macrophages were seeded on 22 mm glass coverslips in 6-well tissue culture plates at a density of  $1 \times 10^6$  cells per well and allowed to adhere overnight. Cells were infected with the appropriate *Francisella* strains as described in section 3.2.4. The coverslips were fixed in 2 % (w/v) paraformaldehyde, 1 % (w/v) sucrose, PBS for 20 min at room temperature followed by permeabilization in 0.5% Triton X-100 for 10 min at room temperature. Coverslips were blocked in PBS containing 5 % lamb serum for 30 minutes. Rabbit polyclonal anti-*F. novicida* (261) and mouse monoclonal anti-ubiquitin FK2 (Enzo Life Sciences) antibodies were incubated with the coverslips for 1 hour at a dilution of 1:1000. Coverslips were then washed three times with PBS and incubated for 2 h with goat anti-rabbit Alexafluor568 and goat anti-mouse Alexafluor488 secondary antibodies (Molecular Probes) at a dilution of 1:1500 and 1:2000, respectively. The coverslips were incubated for 5 min with Hoechst 33258 (Molecular Probes) to label the DNA. Cells were imaged with a Leica DMIREZ inverted fluorescent microscope using a 100x oil immersion lens. Using Openlab 5.1 software, multiple-channel Z stacks

were captured and deconvoluted to observe bacterial association with ubiquitinated proteins.

#### **4.2.8 Western immunoblot analysis**

SDS-PAGE and Western blotting was performed according to standard techniques as described in section 2.2.3. Membranes were stained with Nigrosin to ensure equal sample loading. Rabbit anti-IglA (263), mouse anti-IglB, mouse anti-IglC, and mouse anti-PdpA antibodies were used at dilutions of 1:4,000, and mouse anti-FLAG M2 (Sigma) was used at 1:10,000. Bound antibody was detected using IRDye800-conjugated goat anti-mouse or IRDye800-conjugated goat anti-rabbit antibody (Rockland Immunochemicals) and visualized using the LiCor Odyssey imaging software version 2.1.

#### **4.2.9 Biotinylation of *Francisella outer membrane proteins***

The biotinylation of surface-exposed proteins was performed using the EZ-Link sulfo-NHS-LC-LC-biotin (Pierce) labelling agent. Plate-grown *F. novicida* strains were suspended and washed three times in cold PBS. After washing the bacterial pellet was resuspended in 1ml of PBS after which 250 $\mu$ l of a 15mg ml<sup>-1</sup> solution of sulfo-NHS-LC-LC-biotin was added. Cells were incubated with the biotin solution for 30 minutes at room temperature, pelleted at 8,000  $\times$  g, and washed in 1 ml of biotinylation salt solution (50 mM Tris, 300 mM NaCl, pH 7.5). Bacteria were washed in ice cold PBS, resuspended in 50  $\mu$ l of PBS and then lysed by adding 500  $\mu$ l of B-PERII (Pierce). The lysate was centrifuged at 15,200  $\times$  g for 1 minute and the supernatant was transferred to a

new 1.5-ml tube containing 200  $\mu$ l of Ultralink-immobilized NeutrAvidin beads (Pierce). Tubes were gently rocked for 30 minutes at room temperature and the NeutrAvidin beads (along with any biotin conjugated proteins) were washed in Tris-buffered saline. Protein was recovered by resuspending the pelleted NeutrAvidin beads in SDS-PAGE sample buffer and boiling at 90°C for 10 minutes. The heated mixture was gently pelleted to remove NeutrAvidin beads, and 25  $\mu$ l of supernatant was separated using standard Western immunoblot analysis as described above.

#### **4.2.10 Immunoprecipitation of secreted *Francisella* protein from broth grown culture**

*F. novicida* cultures (20ml) grown overnight were centrifuged at 10,000 rpm for 15 minutes at 4°C and supernatants were passed through a 0.45  $\mu$ M filter. Ice cold TCA was added to the supernatant to a final concentration of 10% and left on ice for 90 minutes. The TCA treated proteins were pelleted by centrifugation at 11,000 rpm for 45 minutes at 4°C. The pellet was washed twice in ice cold acetone and air dried. The dried pellet was resuspended in 50  $\mu$ l of 67 mM Tris, pH 6.8. The protein sample was then analyzed using standard Western immunoblotting techniques.

#### **4.2.11 Immunoprecipitation of secreted *Francisella* protein from infected macrophages**

J774A.1 cells were seeded in 75cm<sup>2</sup> tissue culture flasks and infected with appropriate *F. novicida* strains in a manner similar to the intracellular growth assays described in section 3.2.2. After 4 hours of infection the macrophages were washed and

scraped into PBS and then pelleted in preparation for lysis. Cells were resuspended in 1 ml of ice cold homogenization buffer (250 mM sucrose, 3 mM imidazole (pH 7.4), 0.5 mM EDTA and protease inhibitor) and broken by repeat passage through a 27 <sup>1/2</sup> gauge needle on ice. The sample was centrifuged at 8000 rpm, 10 min, 4°C to remove bacteria, unbroken macrophages and debris. The soluble supernatant containing macrophage proteins and any secreted *F. novicida* proteins was subjected to FLAG-immunoprecipitation according to the manufacturer's instructions (Sigma). Bacterial pellets from the infection were examined by Western immunoblotting with anti-FLAG M2 antibody (Sigma) to make certain that each sample contained a similar amount of bacteria.

#### 4.2.12 Graphing and statistics

The Prism GraphPad v4.03 software was used to generate graphs and to calculate the appropriate statistical values, including standard deviation, standard error of the mean and *P*-values. For *P*-values the log-rank test or two-way ANOVA were used where appropriate.

**Table 4. Bacterial strains and plasmids used in creating targeted deletions within *pdpA* and in studying PdpA function and *Francisella* secretion.**

Strain	Characteristics	Reference
U112	Wild-type <i>F. novicida</i>	ATCC 15482
JLO	U112 with deletion in FTN_1390, where SKX vector inserts; identical growth and virulence with respect to U112	(222)
$\Delta$ <i>mgIA</i>	U112 with point mutation in global virulence regulator, <i>mgIA</i>	(30)

$\Delta pdpA$	JLO with a deletion of <i>pdpA</i>	This study
$\Delta pdpA/SKX::pdpA$	$\Delta pdpA$ complemented with the integrating pJL-SKX:: <i>pdpA</i> construct	This study
<i>pdpA</i> $\Delta$ 112-227	JLO with an in-frame deletion of aa 112-227	This study
<i>pdpA</i> $\Delta$ 112-227/SKX:: <i>pdpA</i>	<i>pdpA</i> $\Delta$ 112-227 complemented with the integrating pJL-SKX:: <i>pdpA</i> construct	This study
<i>pdpA</i> <sub>S121S122</sub> $\rightarrow$ <sub>A121A122</sub>	JLO with serine 121 and 122 of PdpA mutated to alanine residues	This study
<i>pdpA</i> <sub>L127L139</sub> $\rightarrow$ <sub>A127A139</sub>	JLO with leucine 127 and 139 of PdpA mutated to alanine residues	This study
<i>pdpA</i> <sub>K162R164</sub> $\rightarrow$ <sub>A162A164</sub>	JLO with lysine 162 and arginine 164 of PdpA mutated to alanine residues	This study
KM14S	KM14, <i>valAB</i> duplication resolved, serum sensitive mutant	(237)
JLO/pJL-SKX:: <i>anmK-pdpD</i>	JLO complemented with the integrating pJL-SKX:: <i>anmK-pdpD</i> construct	(221)
$\Delta pdpA/pJL-SKX::anmK-pdpD$	$\Delta pdpA$ complemented with the integrating pJL-SKX:: <i>anmK-pdpD</i> construct	This study
$\Delta pdpA/pdpA$ -FLAG	$\Delta pdpA$ complemented with pKH3:: <i>pdpA</i> -FLAG	This study
$\Delta pdpE/pdpE$ -FLAG	$\Delta pdpE$ complemented with pKH3:: <i>pdpE</i> -FLAG	de Bruin <i>et al.</i> , unpublished data
$\Delta pdpE$	JLO with a deletion of <i>pdpA</i>	de Bruin <i>et al.</i> , unpublished data
<b>Plasmids</b>		
pWSK29	Low-copy cloning vector, Ap <sup>r</sup>	(399)
pJL-SKX	pWSK29 with integrating SKX cassette, Km <sup>r</sup> , Amp <sup>r</sup>	(222)
pJL-ES-X	pWSK29 containing an <i>ermCsacB</i> cassette with flanking <i>XhoI</i> restriction sites	(222)
pWSK29:: <i>pdpA</i> $\Delta$ 112-227	A clone containing the fused flanking regions of <i>pdpA</i> aa 112-227; used to create the <i>F. novicida pdpA</i> $\Delta$ 112-227	This study
pJL-SKX:: <i>pdpA</i>	An integrating complementation construct containing the full <i>pdpA</i> gene and its predicted promoter region (522 bp upstream of <i>pdpA</i> start)	This study
pWSK29::	A clone containing the <i>pdpA</i> gene which has	This study

<i>pdpA</i> <sub>S121S122</sub> → <i>A121A122</i>	been altered to mutagenize Ser 121 and Ser 122 to Ala; used to create the <i>F. novicida</i> <i>pdpA</i> <sub>S121S122</sub> → <i>A121A122</i>	
pWSK29:: <i>pdpA</i> <sub>L127L139</sub> → <i>A127A139</i>	A clone containing the <i>pdpA</i> gene which has been altered to mutagenize Leu 127 and Leu 139 to Ala; used to create the <i>F. novicida</i> <i>pdpA</i> <sub>L127L139</sub> → <i>A127A139</i>	This study
pWSK29:: <i>pdpA</i> <sub>K162R164</sub> → <i>A162A164</i>	A clone containing the <i>pdpA</i> gene which has been altered to mutagenize Lys 162 and Arg 164 to Ala; used to create the <i>F. novicida</i> <i>pdpA</i> <sub>K162R164</sub> → <i>A162A164</i>	This study
pKH3:: <i>pdpA</i> -FLAG	A clone containing the <i>pdpA</i> gene in-frame with a 3XFLAG epitope; used to create the <i>F. novicida</i> $\Delta$ <i>pdpA/pdpA</i> -FLAG	Hueffer <i>et al.</i> , unpublished data
pKH3:: <i>pdpE</i> -FLAG	A clone containing the <i>pdpE</i> gene in-frame with a 3XFLAG epitope; used to create the <i>F. novicida</i> $\Delta$ <i>pdpE/pdpE</i> -FLAG	Hueffer <i>et al.</i> , unpublished data
pJL-SKX:: <i>anmK-pdpD</i>	An integrating construct which overexpresses the <i>pdpD</i> gene; used to create the <i>F. novicida</i> $\Delta$ <i>pdpA/pJL-SKX::anmK-pdpD</i>	(221)

## 4.3 Results

### 4.3.1 Intracellular growth and virulence of a *pdpA* $\Delta$ 112-227 mutant

The traditional methods of expressing and isolating soluble protein for structural and functional analysis have been unsuccessful in studying PdpA. For this reason we must utilize bioinformatic tools such as BLASTP and HHpred analysis to provide clues to the possible function of PdpA. PdpA shows no significant similarity to any other protein of known function; however the amino terminus of PdpA shares weak homology with several domains found in proteins involved in ubiquitination. The most intriguing similarity PdpA shared was with the eukaryotic F-box domain (see Figure 17). This domain is found in F-box proteins which are recruited as part of the SCF ubiquitin ligase complex. The amino terminus of the protein contains the F-box domain which interacts

with Skp1 of the SCF complex. The carboxy terminus contains a domain which interacts with various target proteins. Thus the F-box protein brings target proteins to the SCF ubiquitin ligase complex for ubiquitination (200). Deletion of the F-box domain ablates interaction with Skp1 thus preventing ubiquitination of the F-box target protein (18, 25, 200, 336).

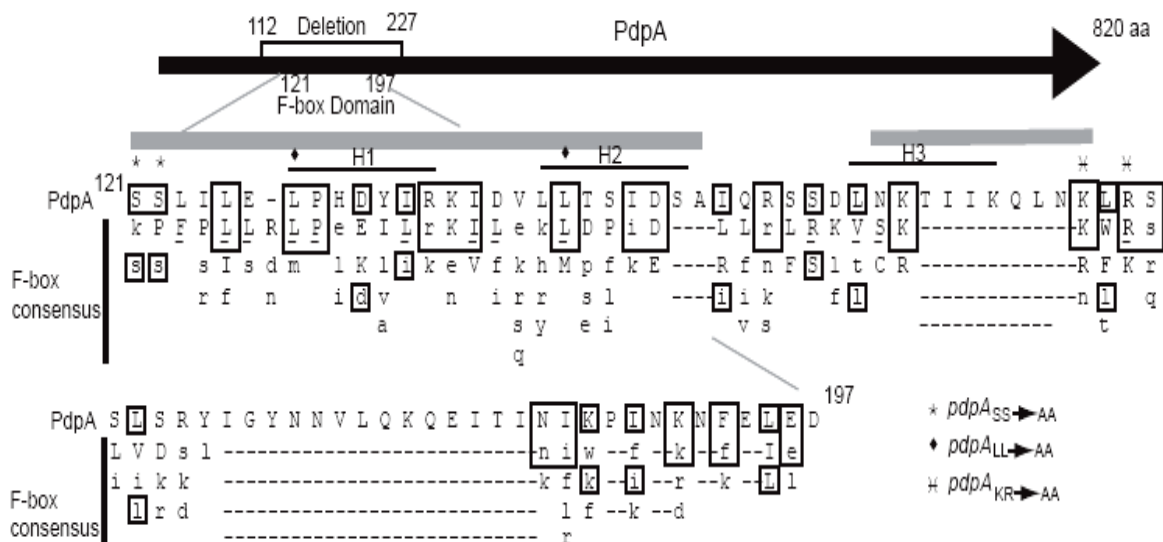
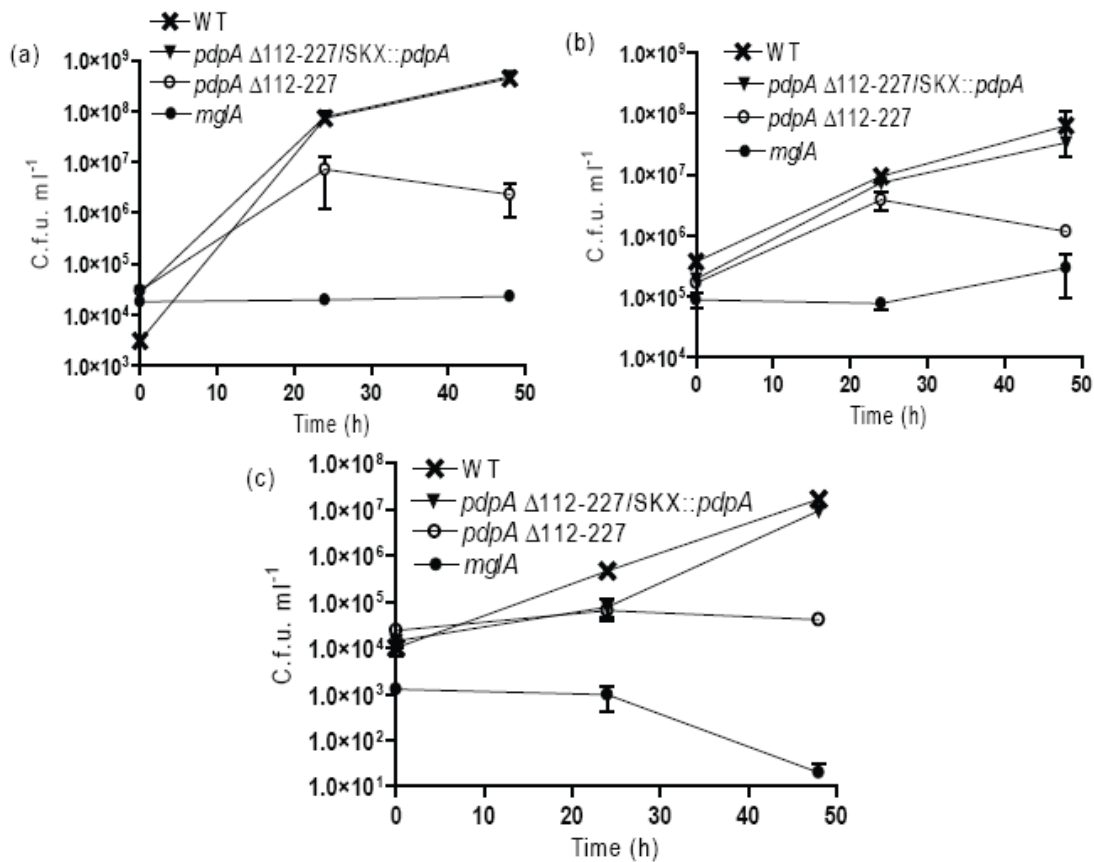

**Figure 17. PdpA F-box alignment and mutagenesis.** Diagrammatic representation of the *pdpA* gene and a partial in-frame deletion. The deleted region encodes a stretch of amino acids (121-197) that show similarity to eukaryotic F-box domains, which are highly degenerate. The symbols show the location of alanine codon substitutions in the three double mutants (two alanine changes for each mutant). Mutated leucine residues 127 and 139 are highly conserved residues essential for F-box protein interactions. H1, H2 and H3 indicate the three alpha helical regions found in F-box domains.

To determine if PdpA contains a functioning F-box domain we deleted amino acids 112-227; the region surrounding the predicted F-box domain (Figure 17). This

deletion was confirmed via PCR analysis and DNA sequencing. Amounts of PdpB protein were also assessed to ensure there were no polarity effects on downstream genes (data not shown). The intracellular growth phenotype of the *pdpA*Δ112-227 mutant was assayed in J774A.1 murine macrophage-like cells and BMDM's. The growth phenotype was very similar to that of the Δ*pdpA* mutant described in chapter 3 (Figure 18a,b). There was restricted growth of the mutant strain with an initial increase followed by a marked decrease in bacterial numbers. Macrophages infected with the *pdpA*Δ112-227 mutant appeared healthy throughout the infection, displaying no signs of cytotoxicity or cell-rounding. Genetic complementation restored intramacrophage growth (Figure 18a,b).

The *pdpA*Δ112-227 mutant was also used to infect NIH 3T3 fibroblasts to determine if *pdpA* mutants behaved similarly in non-leukocyte derived cell lines (Figure 18c). There was no discernable growth of the *pdpA*Δ112-227 mutant within NIH 3T3 cells throughout 48 hours of infection. The *pdpA*Δ112-227 infected fibroblasts appeared healthy and showed no signs of cytotoxicity. Genetic complementation restored wild type intracellular growth (Figure 18c). The *mglA* mutant was again used as a negative control for intracellular growth as it cannot replicate within macrophages but is able to survive at steady state levels. Interestingly, the *mglA* mutant could not survive within the fibroblasts and dropped to barely detectable levels (Figure 18c).



**Figure 18. The *pdpA*Δ112-227 mutant is unable to sustain growth in macrophages and NIH-3T3 fibroblasts.** (a) One week old bone marrow derived macrophages were infected with wild type *F. novicida* and the *pdpA*Δ112-227 mutant. After 24 hours of infection the *pdpA*Δ112-227 mutant was no longer able to replicate within the host cell. Wild type *F. novicida* completely decimated the macrophage population within 24 hours whereas cells infected with the *pdpA*Δ112-227 mutant remained healthy for the entire course of the experiment. (b) A similar pattern was observed when J774A.1 macrophages were infected in the same manner. (c) NIH-3T3 fibroblasts were infected with wild type *F. novicida* and the *pdpA*Δ112-227 mutant. The PdpA mutant was unable to replicate maintaining time zero bacterial burdens during the course of the 48 hour experiment. All data points in (a-c) are representative of three replicates and each experiment was performed in triplicate. Two-way ANOVA was used to calculate the significance of the differences in the growth curves between pairs of strains. For BMDM: WT vs *pdpA*Δ112-227,  $P < 0.001$  and for *pdpA*Δ112-227 vs *pdpA*Δ112-

227/SKX::*pdpA*,  $P < 0.001$ . For J774A.1 macrophages: WT vs *pdpA* $\Delta$ 112-227,  $P = 0.0013$  and for *pdpA* $\Delta$ 112-227 vs *pdpA* $\Delta$ 112-227/SKX::*pdpA*,  $P < 0.0001$ . For NIH 3T3 fibroblasts: WT vs *pdpA* $\Delta$ 112-227,  $P = 0.0006$  and for *pdpA* $\Delta$ 112-227 vs *pdpA* $\Delta$ 112-227/SKX::*pdpA*,  $P = 0.0005$ .

To further investigate the growth of *F. novicida* within NIH 3T3 fibroblasts we studied the association of *pdpA* $\Delta$ 112-227 with LAMP-1 during infection. Very few observed fibroblasts were infected with the *F. novicida* strains. Fibroblasts infected with WT *F. novicida* harboured large bacterial numbers after 19 hours of infection (Figure 19 a-d). The WT bacteria did not co-localize with LAMP-1 at any time point during infection (Figure 19 a-d and data not shown). Fibroblasts infected with *pdpA* $\Delta$ 112-227 mutant contained small clusters of bacteria which did not replicate throughout infection (Figure 19 e). Similar to WT the *pdpA* $\Delta$ 112-227 mutant did not localize with LAMP-1 at any time point during infection (Figure 19 e and data not shown).

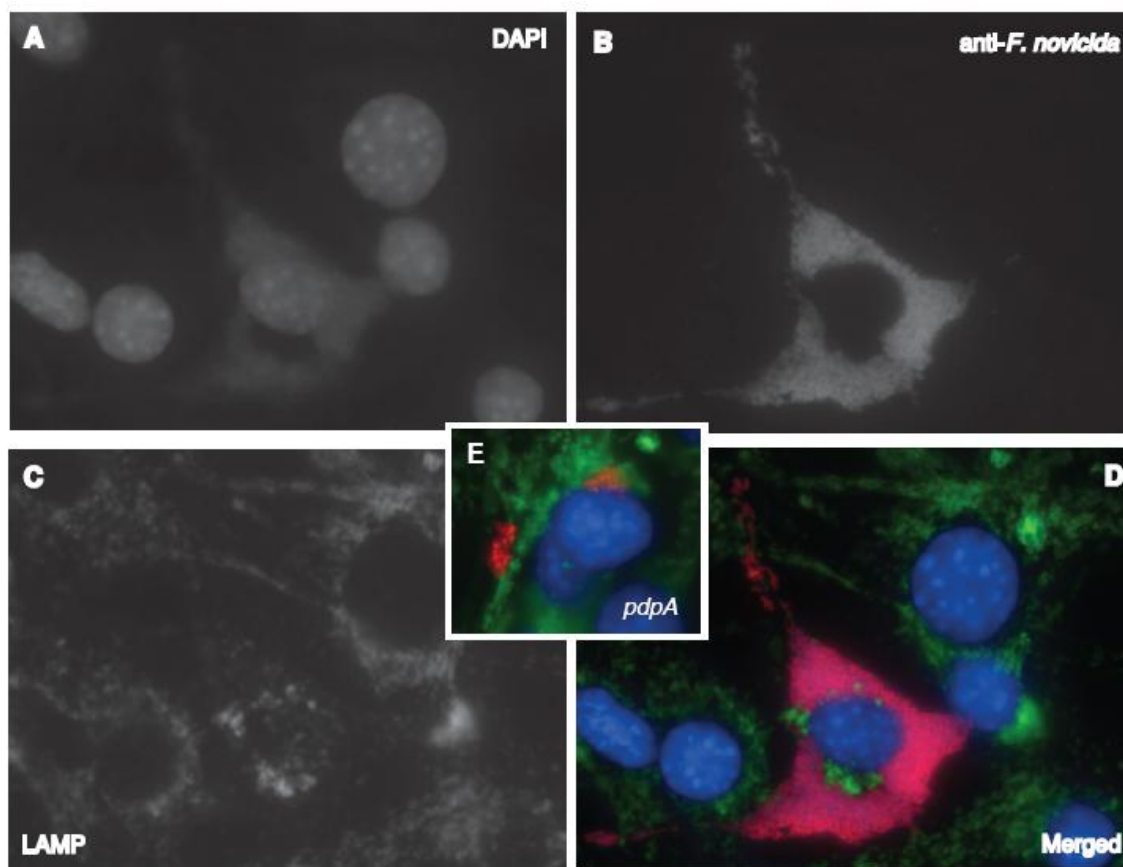

**Figure 19. Intracellular growth and LAMP-1 association of *pdpA*  $\Delta$ 112-227 mutant NIH3T3 fibroblasts.** Fibroblasts were infected with wild type (A-D) and *pdpA* $\Delta$ 112-227 (E) strains of *F. novicida* (red). After 24 hours, infected NIH-3T3 cells are completely filled with the wild type strain (D) while the *pdpA* $\Delta$ 112-227 mutant strain is unable to replicate (E). There is no detectable association of the wild type or PdpA mutant bacterium with LAMP-1 (green). The experiment was performed in duplicate.

The virulence of the *pdpA* $\Delta$ 112-227 mutant was tested using the chicken embryo infection. Using an inoculum of  $10^3$  c.f.u. all WT embryos were killed within 5 days of infection. An equal dose of *pdpA* $\Delta$ 112-227 failed to kill a single embryo. Similar results were observed using an inoculum of  $10^5$  c.f.u. (data not shown).

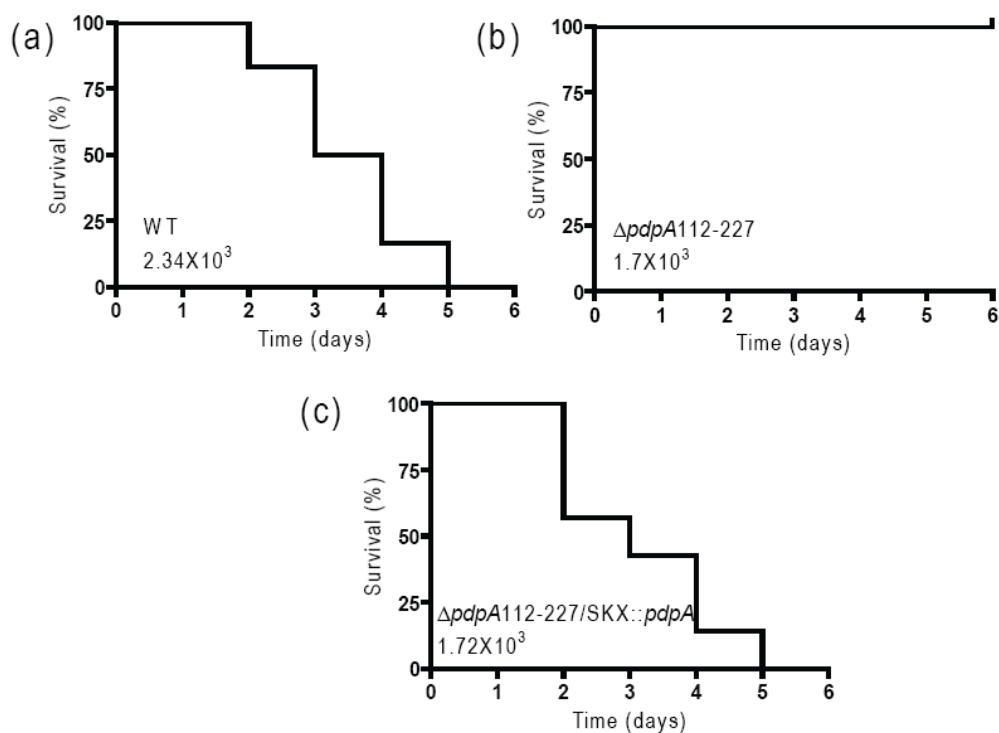
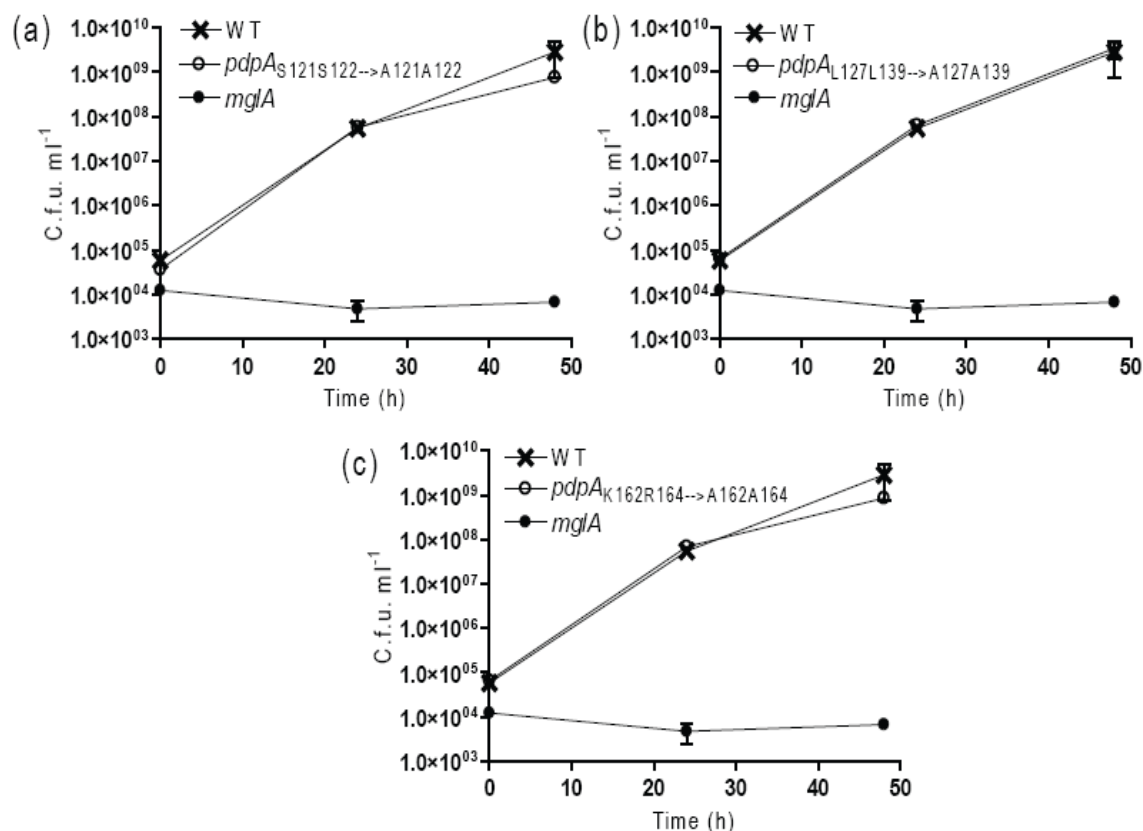

**Figure 20. Attenuation of the *pdpA*  $\Delta$ 112-227 mutant in chicken embryos.** Chicken embryos were infected with wild type *F. novicida* or the *pdpA* $\Delta$ 112-227 strain. An inoculum of  $10^3$  c.f.u. resulted in death of all 7 wild type infected embryos within 3 days. The same inoculum of the *pdpA* $\Delta$ 112-227 mutant resulted in 0 embryo deaths. Wild type phenotype was restored via PdpA *in cis* complementation. The statistical difference between the WT and *pdpA* 112-227 strain survival curve was measured by the log-rank test and yielded a *P*-value of <0.001. The *P*-value for a comparison of *pdpA* 112-227 vs *pdpA* 112-227/SKX::*pdpA* was <0.001.

### 4.3.2 Alanine mutagenesis of the predicted PdpA F-box domain

The deletion of amino acids 112-227 within PdpA may alter the structure of the protein and inhibit its function in a manner that is not attributed to the presence of an F-box domain. The study of eukaryotic F-box proteins and prokaryotic mimics of F-box proteins found that interaction with Skp1 is dependent on 3 key conserved amino acids. Previous studies show that mutation of conserved leucine and proline residues results in either decreased or complete loss of binding of the F-box protein to Skp1 (Figure 17) (25, 204, 336). To more accurately ascertain if PdpA contains an F-box domain, several alanine replacement mutants were created. The *pdpA*<sub>L127L139→A127A139</sub> strain contains mutations in both conserved functional leucine residues (Figure 17). The PdpA proline residue at position 128 was not mutated as this mutation may cause a major structural change which would inhibit protein function, though not necessarily be due to the presence of an F-box domain. Strains *pdpA*<sub>S121S122→A121A122</sub> and *pdpA*<sub>K162R164→A162A164</sub> have mutations within highly conserved F-box amino acid residues which are not associated with protein function.

J774A.1 macrophages were infected with the alanine replacement mutant strains to ascertain their intracellular growth phenotypes. All three mutant strains grew within the macrophages and were indistinguishable from wild type *F. novicida* (Figure 21a-c).



**Figure 21. Intracellular growth of *pdpA* alanine mutants in J774A.1 macrophages.**

Key leucine residues required in the function of F-box domains were mutated within PdpA (b). Mutations were also made in residues which are not thought to be required for the function of the domain (a,c). Macrophage infection with these PdpA alanine mutant strains resulted in an intracellular growth phenotype which was indistinguishable from WT *F. novicida* in all instances (a-c). All data points in (a-c) are representative of three replicates and each experiment was performed in triplicate. There was no statistically significant difference between the intracellular growth of wild type and any alanine mutant strain. WT vs *pdpA*<sub>S121S122→A121A122</sub>,  $P=0.4163$ ; WT vs *pdpA*<sub>L127L139→A127A139</sub>,  $P=0.9487$ ; and for WT vs *pdpA*<sub>K162R164→A162A164</sub>,  $P=0.4397$ .

The virulence of the alanine replacement mutants was assessed using the chicken embryo infection assay. Infection with  $10^3$  c.f.u. of the alanine mutant strains or WT *F. novicida* resulted in the death of 100% of the embryos within 3 days of infection (Figure 22). There was no statistically significant difference between embryo infection with the alanine mutant strains and WT. Similar results were observed when virulence was tested in BALB/cByJ mice, with the alanine mutant strains behaving similarly to wild type *F. novicida* (K. Elkins, personal communication).

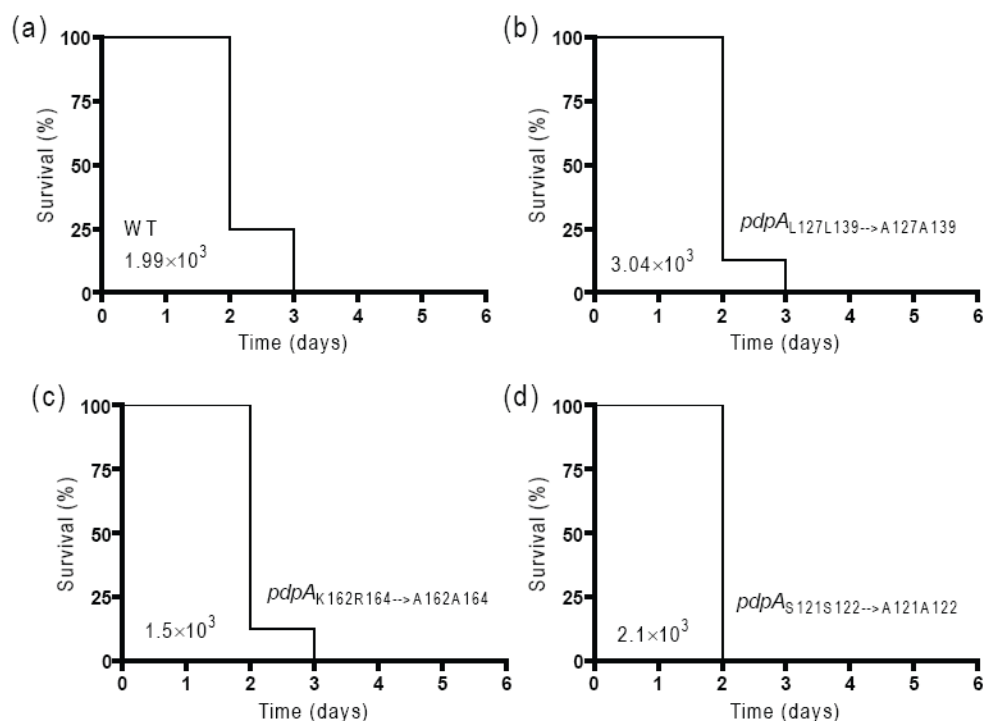
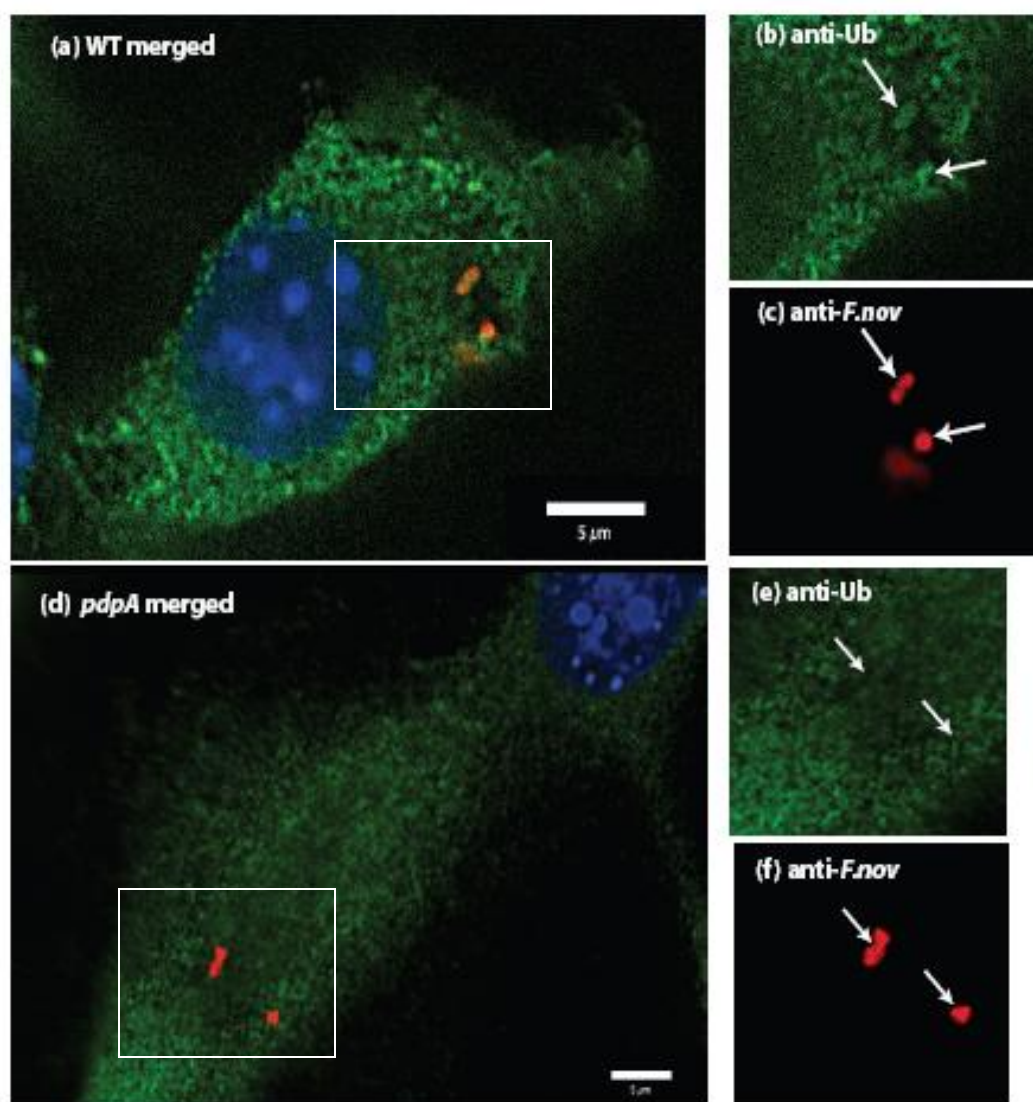

**Figure 22. Attenuation of the *pdpA* alanine mutants in chicken embryos.** Fertilized one week old chicken embryos were infected with  $10^3$  c.f.u. of WT (a) or one of three *PdpA* alanine mutant strains (b-d). All embryos died within 3 days of infection. The experiment was performed in duplicate. The statistical difference between the WT and alanine mutant strain survival curves was not significant as measured by the log-rank test.

WT vs *pdpA*<sub>S121S122→A121A122</sub>,  $P=0.6634$ ; WT vs *pdpA*<sub>L127L139→A127A139</sub>,  $P=0.967$ ; and for WT vs *pdpA*<sub>K162R164→A162A164</sub>,  $P=0.967$ .

### 4.3.3 Ubiquitin association with $\Delta$ *pdpA* containing phagosomes

There are several ubiquitin-proteasome linked domain homologies found within PdpA using HHpred software. Ubiquitination and a functional proteasome are required for several phagosome maturation events (212). Because PdpA is required for *F. novicida* to escape the macrophage phagosome we studied the differences in ubiquitinated protein association between WT and  $\Delta$ *pdpA* containing phagosomes. After 20 minutes of macrophage infection there was no discernable difference between ubiquitination patterns surrounding WT and  $\Delta$ *pdpA* strains (data not shown). Both strains were closely associated with ubiquitinated proteins and many bacteria were surrounded by a ubiquitin laden structure similar to that observed with the LAMP-1 association described in section 3.3.2. After 1 hour of infection there was a noticeable difference in the ubiquitin staining of both strains (Figure 23). The  $\Delta$ *pdpA* mutant showed decreased association with ubiquitinated proteins (Figure 23 d-f) whereas the WT strain stained much more intimately with the ubiquitin antibody (Figure 23 a-c). It should be noted that the ubiquitin antibody used (FK2) recognizes only mono and polyubiquitinated proteins, not free ubiquitin.



**Figure 23. The association of the  $\Delta pdpA$  mutant with mono and polyubiquitinated proteins.** (a-c) Wild type *F. novicida* associates closely with the FK2 anti-ubiquitin antibody 1 hour after J774A.1 macrophage infection. (d-f)  $\Delta pdpA$  shows very limited association with ubiquitinated proteins after 1 hour of infection. The colours in merged panels a and d correspond to Hoechst DNA (blue), anti-Ub (green), and anti-*F. novicida* (red). The arrowheads indicate areas of ubiquitin staining that correspond to bacterial location. The experiment was performed in duplicate.

To discern the importance of proteasome function during *Francisella* infection J774A.1 macrophages were treated with the proteasome inhibitor MG132 prior to and during initial infection with *F. novicida* strains. Intracellular growth of the bacteria was compared between MG132 treated and mock-treated macrophages. Wild type *F. novicida* growth was nearly identical between treated and untreated cells (data not shown). There was a slight difference in  $\Delta pdpA$  growth between MG132 treated and untreated cells. The  $\Delta pdpA$  mutant grew more poorly after 24 hours of infection in MG132 treated cells (data not shown); however this defect was also observed in the growth of an attenuated serum sensitive mutant strain implying that the growth defect is not PdpA specific.

#### 4.3.4 Biotinylation of surface exposed *Francisella* proteins

The *Francisella* FPI has recently proved to encode a unique type VI secretion system. To date, no *Francisella* protein has been confirmed as an effector protein translocated via this T6SS. The assay currently used to ascertain whether a protein is involved in secretion is the localization of IglC to the outer membrane. If the secretion system is operational IglC localizes to the outer membrane of *Francisella*. However, if proteins involved in assembling the secretion apparatus, such as PdpB or DotU, are absent IglC fails to localize to the outer membrane (221). The IglA and IglB proteins have also been found to localize to the outer membrane but in a non-T6SS dependent manner (221). Biotinylation of surface exposed proteins was compared as performed by Ludu *et al.*, this time using the JLO/pJL-SKX::*anmK-pdpD* and  $\Delta pdpA$ /pJL-SKX::*anmK-pdpD* strains (221). PdpA was not detected as a biotinylated surface exposed protein (Figure 24). IglA,B, and C were all detected as biotinylated surface exposed proteins,

even in a  $\Delta pdpA/pJL-SKX::anmK-pdpD$  background (Figure 24). Bacterial pellets of each strain were also probed with the antibodies to ensure the desired proteins were being expressed (data not shown).

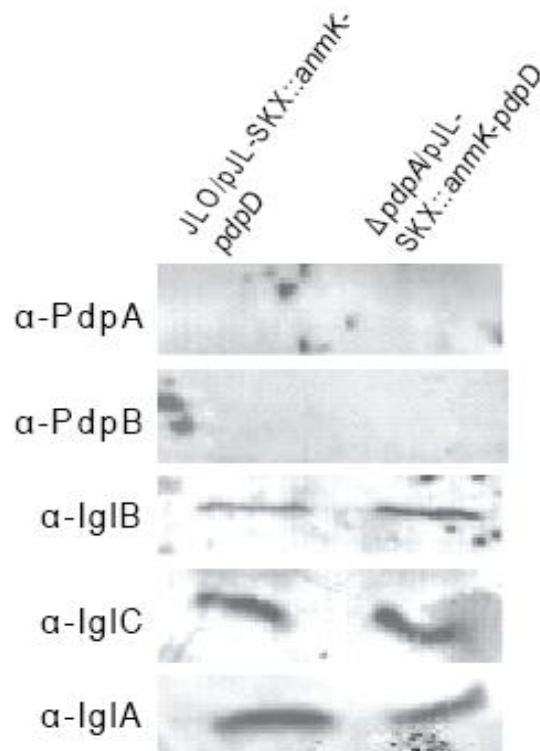

**Figure 24. Biotinylation of surface exposed proteins in wild type and  $\Delta pdpA$  backgrounds.** Reactivity of biotinylated surface exposed proteins with anti-PdpA, PdpB, IgIB, IgIC, and IgIA monoclonal antibodies. The right hand panel represents proteins surface exposed in a  $\Delta pdpA$  background. Results are representative of those performed in duplicate.

#### 4.3.5 Precipitation of secreted *Francisella* proteins

The creation of FLAG tagged FPI proteins allowed for the use of more sensitive assays to detect protein secretion. The secreted protein IglC has been detected in the supernatant of broth grown *F. novicida* using TCA precipitation and Western immunoblotting (de Bruin *et al.*, unpublished data). The TCA precipitated supernatants of WT *F. novicida*,  $\Delta pdpA/ pdpA$ -FLAG broth grown cultures were probed using antibodies against IglC, and the 3XFLAG epitope. *pdpA*-FLAG is able to restore the wild type intramacrophage growth phenotype to a  $\Delta pdpA$  mutant and as such  $\Delta pdpA/ pdpA$ -FLAG is an appropriate complement strain (data not shown). The IglC protein was detected in the supernatant of both strains (Figure 25). *PdpA*-FLAG was not detected in the supernatant of broth grown  $\Delta pdpA/ pdpA$ -FLAG (Figure 25). Bacterial pellets of each strain were also probed with the antibodies to ensure the desired proteins were being expressed.

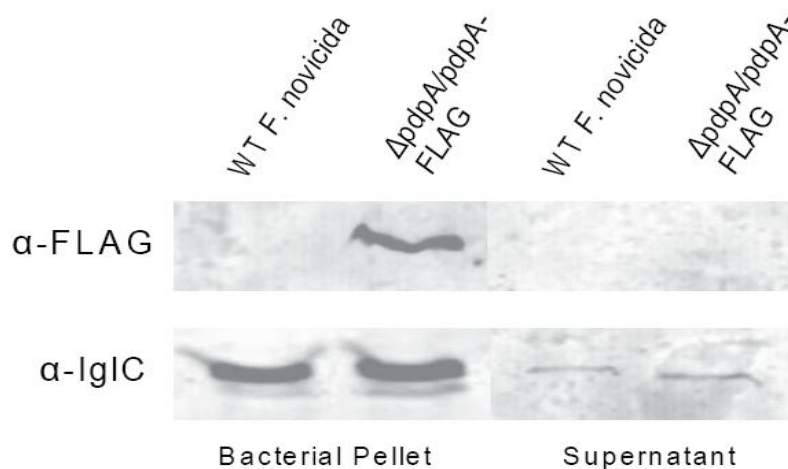

**Figure 25. Detection of *Francisella* proteins secreted into the supernatant of broth grown culture.** Immunoblot of PdpA-FLAG and IglC in broth grown cultures and in the TCA precipitated supernatant of the broth grown cultures. IglC was probed as a positive control for secreted protein. Results are representative of those performed in duplicate.

To determine if PdpA is secreted during a macrophage infection, J774A.1 macrophages were infected with wild type or  $\Delta pdpA/pdpA$ -FLAG strains for four hours. Proteins present in the macrophage cytosol were immunoprecipitated using  $\alpha$ -FLAG conjugated beads. Bound proteins were analyzed by SDS-PAGE and Western blotting. The PdpA-FLAG protein was not detected among the proteins isolated from the macrophage cytosol but was clearly being expressed by the bacterium (Figure 26a). Bacterial pellets isolated from the infection were also analyzed via Western blot to confirm expression of the target FLAG tagged protein. The FPI protein PdpE has been detected in the cytosol of infected macrophages using both immunoprecipitation and immunofluorescence techniques (de Bruin *et al.*, unpublished data). Infection with

$\Delta pdpE/pdpE$ -FLAG resulted in easily detectable amounts of PdpE-FLAG within the macrophage cytosol (Figure 26b).

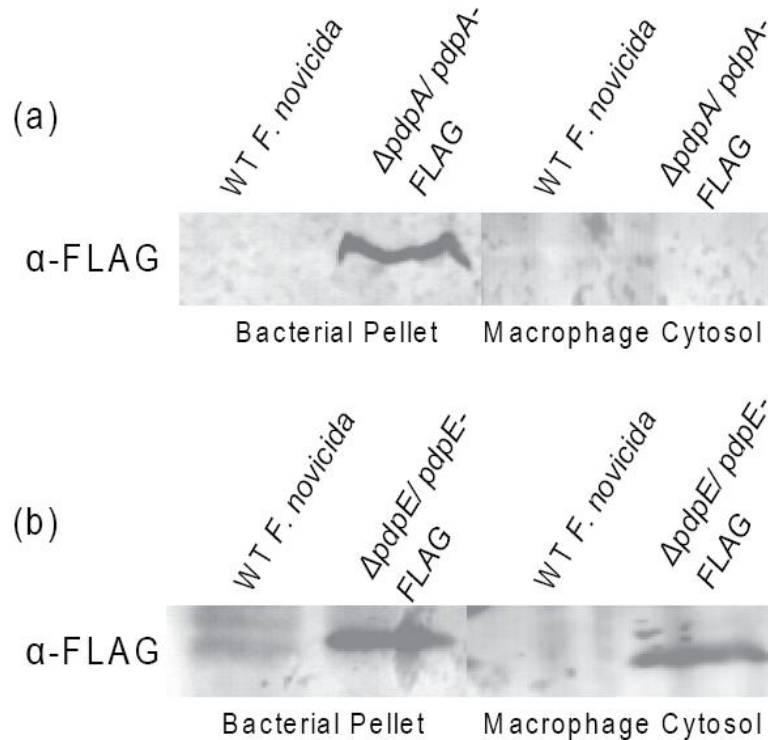

**Figure 26. PdpA-FLAG is not secreted into the macrophage cytosol during infection.** Western blot of proteins immunoprecipitated from the cytosol of J774A.1 macrophages using  $\alpha$ -FLAG antibody conjugated agarose beads. (a) Shows that though PdpA-FLAG is being expressed in the bacterial pellet it cannot be detected in the macrophage cytosol. (b) Demonstrates that PdpE-FLAG is secreted into the host cell cytosol. No FLAG tagged proteins of the appropriate size were detected in  $\Delta pdpA$  or  $\Delta pdpE$  backgrounds (data not shown). Results are representative of those performed in triplicate.

#### 4.4 Discussion

Bacterial pathogens are constantly evolving, acquiring new tools with which to manipulate their host and establish a replicative niche. In many cases bacteria are able to utilize host cell processes for their own gain. This host cell hijacking often occurs by using protein mimicry which can arise through convergent evolution or horizontal gene transfer (113, 351, 353). Many bacterial protein mimics are involved in manipulating host cell ubiquitination pathways (19, 315, 351). This interference commonly acts to prevent the activation of NF $\kappa$ B, an important transcription factor which regulates many genes, including those involved in innate and adaptive immunity (198, 351, 416). In some cases bacterial proteins utilize host cell ubiquitination to target secreted effector proteins for degradation when they are no longer required in the infective process (203, 314, 412). The best characterized example of this type of manipulation is the F-box protein VirF of *A. tumefaciens*. Though the F-box domain is normally found in eukaryotic proteins, VirF contains an F-box domain which acts to target secreted effector proteins for ubiquitination and subsequent degradation via the host cell's 26S proteasome (336, 380).

The *Francisella* protein PdpA has proved to be very difficult to study using traditional methods of cloning and isolation of soluble protein. Despite exhausting classical methods of studying novel proteins there were no clues concerning the possible function of PdpA. Bioinformatic analysis of PdpA using both BLASTP and HHpred found several homologies to protein domains involved in the ubiquitin proteasome pathway. The best characterized domain found in these searches was the F-box domain. Amino acid residues required for interaction with Skp1, the interactive partner of F-box

proteins have been identified in both eukaryotic F-box domains and the prokaryotic F-box domain mimic VirF (25, 336, 338). Complete deletion of the predicted F-box domain in PdpA resulted in a mutant strain which displayed similar intracellular growth and virulence characteristics with a  $\Delta pdpA$  mutant. Upon the creation of a monoclonal antibody against PdpA, immunoblot analysis of the  $pdpA\Delta 112-227$  strain failed to detect the truncated protein. It is likely that this mutant protein was unstable and degraded by the bacterium essentially resulting in the creation of a  $\Delta pdpA$  deletion mutant.

The WT *F. novicida* and  $pdpA\Delta 112-227$  infection of NIH 3T3 fibroblasts revealed a unique growth phenotype of *Francisella* within non-monocytic cells. Though the  $pdpA\Delta 112-227$  mutant was unable to replicate within these cells, there was no association of either strain of the bacterium with LAMP-1 as is seen during a macrophage infection. This phenomenon has also been observed during *F. novicida* infection of epithelial cells (J.A.Guttman, personal communication). Because these cell lines are not involved in immune defence there may be a unique pathway in which *Francisella* travels within these cells.

Alanine mutagenesis was performed to determine if conserved F-box domain residues were important in the function of PdpA during infection. According to previous studies the conserved leucine-proline pair at positions 8 and 9 in the F-box consensus sequence and the leucine at position 20 are key residues involved in interaction with Skp1 (25, 338). Alanine mutagenesis of the Leu 8 Pro 9 pair or the Leu 20 residue of the F-box domain of Cdc4, a yeast F-box protein, resulted in severely reduced or complete loss of Skp1 binding (25). Schrammeijer *et al.* made a similar observation while studying VirF. When the leucine and proline residues were mutated to alanine VirF was no longer

able to bind to Skp1 (336). The crystal structure of human Skp1 interacting with the F-box protein Skp2 shows that Leu 8, Pro 9 and Leu 20 all make direct contact with Skp1 (338). Because proline mutation can cause major structural changes in the protein only the conserved leucine residues of PdpA were mutated. The *pdpA*<sub>L127L139→A127A139</sub>, *pdpA*<sub>S121S122→A121A122</sub> and *pdpA*<sub>K162R164→A162A164</sub> strains behaved exactly like WT *F. novicida* when grown in J774A.1 macrophages. The strains were also as virulent as WT in a chicken embryo and mouse infection. These results suggest that PdpA does not contain a functional F-box domain and that Ser 121, Ser 122, Leu 127, Leu 139, Lys 162, and Arg 164 are not required for the function of PdpA in *Francisella* intracellular growth and virulence.

Studying the role of ubiquitination in the maturation of the *Francisella* containing phagosome was accomplished using immunofluorescence. Approximately 20 minutes after the initial uptake of both WT and  $\Delta$ *pdpA* strains there was a ring like structure laden with both mono and polyubiquitinated proteins surrounding many individual bacteria of both strains. This is similar to the LAMP-1 laden structure discussed in chapter 3 and likely represents the phagosomal membrane. The WT strain exhibited a new ubiquitin association pattern 1 hour post infection. The majority of the WT bacteria stained very closely with the FK2 antibody, indicating that surface exposed bacterial proteins were being ubiquitinated or perhaps ubiquitinated host proteins were associating with the bacterium. At this point during infection WT *F. novicida* will have begun phagosomal escape and be exposed to the host cell cytosol. Experiments performed by Perrin *et al.* found that *S. typhimurium* cells that escape the SCV become heavily associated with ubiquitinated proteins in the host cytosol (289). They also found that WT *L.*

*monocytogenes* did not associate with ubiquitinated proteins within the cytosol however when the bacterium was unable to utilize its actin based motility it became heavily associated with ubiquitinated proteins (289). This observation implies that pathogens which are able to utilize actin based motility can avoid recognition by the ubiquitin system. At this point it is not clear what role ubiquitin labelling plays in pathogen recognition by the host cell. After 1 hour of infection the  $\Delta pdpA$  mutant exhibited decreased association with ubiquitinated proteins. This decrease may be indicative of the state of the  $\Delta pdpA$  containing phagosome as ubiquitination patterns will likely vary at different stages during phagosome maturation. At this time point the majority of WT bacteria will have already begun degrading the phagosome membrane to escape into the cytosol whereas the  $\Delta pdpA$  strain will continue to reside within a LAMP-1 laden phagosomal compartment. More work is needed to determine whether the  $\Delta pdpA$  containing phagosome continues to mature and fuse with the lysosome and whether this fusion results in the degradation of the bacterium.

Because the proteasome is involved in the degradation of polyubiquitinated proteins (315) and maturation of the phagosome (43, 212) we wanted to observe the effects of inhibiting proteasome activity during the maturation of the *Francisella* containing phagosome. Previous studies involving the inhibition of the macrophage proteasome during an *S. typhimurium* infection resulted in the destabilization of the SCV and increased the levels of bacterial replication in the cytosol 4 fold (289). However, this effect was not observed when *S. typhimurium* was used to infect epithelial cells, once again highlighting differences in the infection of non-monocytic cell lines. If PdpA is directly involved in some aspect of ubiquitination or phagosome maturation this

proteasome inhibition may substitute for the actions of the PdpA protein and rescue the intracellular growth phenotype of this strain. However, inhibition of the proteasome did not rescue the  $\Delta pdpA$  mutant and instead slightly reduced the intracellular growth of the strain. The negative control serum sensitive mutant, KM14S, was affected in a similar manner to  $\Delta pdpA$  and implies that this growth inhibition is not specific to the presence or absence of PdpA. Intracellular growth of WT *F. novicida* was not affected by proteasome inhibition and does not appear to play a dominant role in the maturation of the *Francisella* containing phagosome.

The deletion of PdpA prevents the escape of *F. novicida* from the phagosome and results in a strain which remains LAMP-1 associated even after 19 hours of infection. PdpA may be an effector protein which directly acts to disrupt the phagosomal membrane. To do so the protein would have to be surface exposed or secreted into the host cell, likely via the FPI encoded T6SS. In order to determine whether PdpA is a component of the T6SS or an effector protein transported via this system several experiments were performed. The current assay used to assess the function of the T6SS in *Francisella* is the localization of IglC to the bacterium's outer membrane (221). To determine which proteins were exposed on the outer membrane of WT and  $\Delta pdpA$  strains of *F. novicida* the exposed proteins were biotinylated and isolated using NeutrAvidin beads. PdpA was not detected on the surface of the bacterium while IglA, B and C were. IglA and IglB have been shown to localize to the outer surface of the bacterium but this localization is not dependent on the presence of genes essential for type VI secretion (221). IglC fails to localize to the bacterial surface if genes essential for secretion, such as *pdpB* and *dotU*, are absent (221). The absence of PdpA does not affect the localization

of IglC to the surface of *F. novicida* and as such does not play an obvious role in the T6SS. However, very little is known about this newly identified system and current assays may not be sufficient in determining whether or not a protein is involved in the assembly and/or function of the *Francisella* secretion system.

Because PdpA does not appear to be involved in type VI secretion but is vital in phagosomal escape, the protein may be a secreted effector protein. The IglC protein can be isolated from broth grown *F. novicida* supernatants (de Bruin *et al.*, unpublished data). IglC and PdpE can also be detected in the cytosol of infected macrophages (de Bruin *et al.*, unpublished data). In an effort to determine if PdpA is a secreted protein both TCA precipitated broth grown culture supernatants and infected macrophage cytosol proteins were analyzed via Western immunoblot analysis. PdpA-FLAG could not be detected in the supernatants of broth grown *pdpA*-FLAG expressing *F. novicida* cultures. The IglC protein was easily detected in the supernatants of both *pdpA*-FLAG and  $\Delta$ *pdpA* strains, again demonstrating that PdpA is not required for the secretion of IglC. The *pdpA*-FLAG expressing strains were used because the M2  $\alpha$ -FLAG antibody is much more sensitive than the  $\alpha$ -PdpA monoclonal antibody. The cytosol of *pdpA*-FLAG and *pdpE*-FLAG infected macrophages were analyzed via immunoblotting using  $\alpha$ -FLAG antibody. PdpE-FLAG was easily identified within the macrophage cytosol whereas the PdpA-FLAG protein could not be detected. These results must be interpreted carefully as the timing of the infection during experiments and the limits of detection may hinder the identification of PdpA as a secreted protein. This combination of experiments demonstrates that PdpA cannot be detected as a surface exposed or secreted protein. PdpA may be a structural component or accessory protein involved in the function of the

T6SS which cannot be identified using our current assays. Further work is needed to characterize the system's structure and effector proteins transported by this newly discovered secretion system.

## Chapter 5: Conclusions and future studies

Though several virulence factors have been identified in *Francisella tularensis*, very few have a well defined role in intracellular growth or a characterized functional mechanism. The FPI contains many genes which encode proteins that are essential in the intracellular growth and virulence of *F. tularensis*. A large portion of these genes are now thought to be involved in the assembly and structure of a T6SS required to export effector proteins outside of the bacterium (de Bruin *et al.*, unpublished data). The remaining proteins encoded within the FPI are believed to be effector proteins translocated by the *Francisella* secretion system, though their function remains unknown.

This dissertation focussed on the characterization of the FPI protein PdpA and its role in the intracellular growth and virulence of *F. novicida*. Several FPI proteins are expressed in very low amounts, making them difficult to detect using many experimental methods. Deng *et al.* were unable to detect PdpA as a protein upregulated in low iron conditions despite their qRT-PCR analysis indicating a 2.6 fold increase in *pdpA* gene expression (109). Studies performed by Lenco and colleagues were only able to detect FPI proteins which are normally expressed at high levels (IglA,B and C) in cell extracts of LVS cells grown in iron-limiting media (214). The production of a mouse monoclonal antibody allowed us to confirm that PdpA levels are indeed upregulated in low iron conditions and that protein expression is dependent on the presence of the transcriptional regulators *mgIA* and *mgIB*. Many previous studies may have failed to detect PdpA based purely on expression levels being lower than the detection limits, a major hurdle in studying this protein.

The study of *pdpA* through deletion mutagenesis has provided a great deal of insight into the gene's function. Deletion of the entire *pdpA* gene severely attenuates *Francisella* virulence in chicken embryos and mice. Closer analysis of the intracellular growth phenotype of  $\Delta pdpA$  found that the strain remains LAMP-1 associated even after 19 hours of infection. Thus the  $\Delta pdpA$  mutant cannot escape the phagosome and is severely impaired for intracellular replication. The  $\Delta pdpA$  112-227 strain is unable to replicate not only in macrophages, but also in fibroblast cells, indicating that the gene is not needed solely for replication in monocyte derived cells. Analysis of the host cell mRNA expression levels indicates that the absence of PdpA results in an increased expression of genes encoding ligands, suggesting that PdpA plays a role in suppressing the infected macrophage's ability to recruit and stimulate uninfected immune cells. However because the  $\Delta pdpA$  mutant is unable to escape the phagosome and replicate intracellularly this mRNA expression profile may not be unique to a  $\Delta pdpA$  mutant. Other mutants that fail to escape the phagosome, such as the  $\Delta mglA$  or  $\Delta iglC$  strains, may produce similar mRNA expression profiles which are a result of the bacterium's inability to replicate intracellularly, thus activating macrophage signalling pathways.

Bioinformatics analysis indicated that PdpA may contain an F-box domain or be utilizing host cell ubiquitin-proteasome machinery in other ways during infection. Targeted alanine mutagenesis coupled with intramacrophage growth and virulence assays demonstrated that PdpA does not contain a functional F-box domain. Ubiquitin immunofluorescence and proteasome inhibition assays were also unable to provide useful insight into the function of PdpA despite revealing important characteristics concerning the maturation of *Francisella* containing phagosomes.

In spite of the importance of *pdpA* during intracellular growth, it has yet to be established whether the protein functions as a secreted effector or perhaps as a functional component of the T6SS. Current lack of knowledge concerning the newly discovered *Francisella* secretion system makes it difficult to discern if PdpA plays a role in secretion. Based on the current assay of IglC localization to the outer membrane of *Francisella* it would appear that PdpA is not a component of type VI secretion. However, all experiments performed to date have failed to detect PdpA as a secreted effector protein. The relatively low amounts of PdpA produced, coupled with the lack of information concerning type VI secretion make it very difficult to accurately define the exact role of PdpA in *Francisella* infection. It can only be concluded that PdpA plays an essential role in phagosomal escape and thus the intracellular replication and virulence of *Francisella* species.

Future research concerning the function of PdpA will focus on further characterizing the behaviour of *pdpA* mutants rather than direct studies of the protein. A great deal of experiments have been performed in an effort to express and isolate recombinant protein in a variety of hosts; all of these experiments have failed as the protein is difficult to clone and incredibly insoluble when expressed in a host other than *Francisella*.

A great deal of knowledge can be gained by studying the *Francisella* containing phagosome in more detail. Comparisons can be made between the differences in timing and acquisition of phagosomal markers by wild type *F. novicida*,  $\Delta pdpA$ , and other mutants defective in phagosomal escape. These differences may provide insight into the

exact role of certain FPI proteins, especially PdpA, as well as offer a better understanding of *Francisella*'s interaction with the host cell.

The controlled expression of *pdpA* using a Tet repressor-based system could also be useful in determining exactly when PdpA is needed throughout intracellular growth. PdpA may perform multiple functions, not only those involved in phagosomal escape. Tools are currently being developed which would allow us to co-infect macrophages with fluorescently tagged wild type and  $\Delta$ *pdpA* strains. Analyzing these infections using immunofluorescence microscopy could help determine if proteins expressed by a wild type *F. novicida* can rescue the  $\Delta$ *pdpA* mutant, allowing it to escape the phagosome and replicate intracellularly.

Whether PdpA is part of *Francisella*'s T6SS or is a secreted effector protein remains unclear. However, the creation of more effective tools and techniques to study FPI proteins as well as increasing knowledge about type VI secretion will help to more clearly define the function of PdpA, a protein essential to the intracellular growth and virulence of *Francisella tularensis*.

## Chapter 6: Bibliography

1. Abd, H., T. Johansson, I. Golovliov, G. Sandstrom, and M. Forsman. 2003. Survival and growth of *Francisella tularensis* in *Acanthamoeba castellanii*. *Appl Environ Microbiol* 69:600-6.
2. Abramovitch, R. B., R. Janjusevic, C. E. Stebbins, and G. B. Martin. 2006. Type III effector AvrPtoB requires intrinsic E3 ubiquitin ligase activity to suppress plant cell death and immunity. *Proc Natl Acad Sci U S A* 103:2851-6.
3. Abramovitch, R. B., and G. B. Martin. 2005. AvrPtoB: a bacterial type III effector that both elicits and suppresses programmed cell death associated with plant immunity. *FEMS Microbiol Lett* 245:1-8.
4. Abu-Arish, A., D. Frenkiel-Krispin, T. Fricke, T. Tzfira, V. Citovsky, S. G. Wolf, and M. Elbaum. 2004. Three-dimensional reconstruction of *Agrobacterium* VirE2 protein with single-stranded DNA. *J Biol Chem* 279:25359-63.
5. Acconcia, F., S. Sigismund, and S. Polo. 2009. Ubiquitin in trafficking: the network at work. *Exp Cell Res* 315:1610-8.
6. Adam, T. 2001. Exploitation of host factors for efficient infection by *Shigella*. *Int J Med Microbiol* 291:287-98.
7. Aderem, A., and D. M. Underhill. 1999. Mechanisms of phagocytosis in macrophages. *Annu Rev Immunol* 17:593-623.
8. Albert-Weissenberger, C., C. Cazalet, and C. Buchrieser. 2007. *Legionella pneumophila* - a human pathogen that co-evolved with fresh water protozoa. *Cell Mol Life Sci* 64:432-48.
9. Alibek, K. 1999. *Biohazard*. N.R. & House New York, New York.
10. Allen, L. A., and A. Aderem. 1996. Molecular definition of distinct cytoskeletal structures involved in complement- and Fc receptor-mediated phagocytosis in macrophages. *J Exp Med* 184:627-37.
11. Allen, W. P. 1962. Immunity against tularemia: passive protection of mice by transfer of immune tissues. *J. Exp. Med.* 115:411-420.
12. Alvarez-Dominguez, C., A. M. Barbieri, W. Beron, A. Wandinger-Ness, and P. D. Stahl. 1996. Phagocytosed live *Listeria monocytogenes* influences Rab5-regulated in vitro phagosome-endosome fusion. *J Biol Chem* 271:13834-43.
13. Amer, A. O., and M. S. Swanson. 2005. Autophagy is an immediate macrophage response to *Legionella pneumophila*. *Cell Microbiol* 7:765-78.
14. Amerik, A. Y., and M. Hochstrasser. 2004. Mechanism and function of deubiquitinating enzymes. *Biochim Biophys Acta* 1695:189-207.
15. Ancuta, P., R. Pedron, R. Girard, G. Sandström, and Chaby. 1996. Inability of the *Francisella tularensis* lipopolysaccharide to mimic or to antagonize the induction of cell activation by endotoxins. *Infect. Immun.* 64:2041-2046.
16. Andersson, H., B. Hartmanova, R. Kuolee, P. Ryden, W. Conlan, W. Chen, and A. Sjostedt. 2006. Transcriptional profiling of host responses in mouse lungs following aerosol infection with type A *Francisella tularensis*. *J Med Microbiol* 55:263-71.
17. Andersson, S. G., A. Zomorodipour, J. O. Andersson, T. Sicheritz-Ponten, U. C. Alsmark, R. M. Podowski, A. K. Naslund, A. S. Eriksson, H. H. Winkler, and C.

- G. Kurland. 1998. The genome sequence of *Rickettsia prowazekii* and the origin of mitochondria. *Nature* 396:133-40.
18. Angot, A., N. Peeters, E. Lechner, F. Vaillau, C. Baud, L. Gentzbittel, E. Sartorel, P. Genschik, C. Boucher, and S. Genin. 2006. *Ralstonia solanacearum* requires F-box-like domain-containing type III effectors to promote disease on several host plants. *Proc Natl Acad Sci U S A* 103:14620-5.
  19. Angot, A., A. Vergunst, S. Genin, and N. Peeters. 2007. Exploitation of eukaryotic ubiquitin signaling pathways by effectors translocated by bacterial type III and type IV secretion systems. *PLoS Pathog* 3:e3.
  20. Anthony, L. D., R. D. Burke, and F. E. Nano. 1991. Growth of *Francisella* spp. in rodent macrophages. *Infect Immun* 59:3291-6.
  21. Anthony, L. S., M. Z. Gu, S. C. Cowley, W. W. Leung, and F. E. Nano. 1991. Transformation and allelic replacement in *Francisella* spp. *J Gen Microbiol* 137:2697-703.
  22. Ardley, H. C., and P. A. Robinson. 2005. E3 ubiquitin ligases. *Essays Biochem* 41:15-30.
  23. Armstrong, J. A., and P. D. Hart. 1975. Phagosome-lysosome interactions in cultured macrophages infected with virulent tubercle bacilli. Reversal of the usual nonfusion pattern and observations on bacterial survival. *J Exp Med* 142:1-16.
  24. Astarie-Dequeker, C., S. Carreno, C. Cougoule, and I. Maridonneau-Parini. 2002. The protein tyrosine kinase Hck is located on lysosomal vesicles that are physically and functionally distinct from CD63-positive lysosomes in human macrophages. *J Cell Sci* 115:81-9.
  25. Bai, C., P. Sen, K. Hofmann, L. Ma, M. Goebel, J. W. Harper, and S. J. Elledge. 1996. SKP1 connects cell cycle regulators to the ubiquitin proteolysis machinery through a novel motif, the F-box. *Cell* 86:263-74.
  26. Baker, C. N., D. G. Hollis, and C. Thornsberry. 1985. Antimicrobial susceptibility testing of *Francisella tularensis* with a modified Mueller-Hinton broth. *J Clin Microbiol* 22:212-5.
  27. Bakowski, M. A., V. Braun, and J. H. Brumell. 2008. *Salmonella*-containing vacuoles: directing traffic and nesting to grow. *Traffic* 9:2022-31.
  28. Ballister, E. R., A. H. Lai, R. N. Zuckermann, Y. Cheng, and J. D. Mougous. 2008. In vitro self-assembly of tailorable nanotubes from a simple protein building block. *Proc Natl Acad Sci U S A* 105:3733-8.
  29. Barker, J. H., J. Weiss, M. A. Apicella, and W. M. Nauseef. 2006. Basis for the failure of *Francisella tularensis* lipopolysaccharide to prime human polymorphonuclear leukocytes. *Infect Immun* 74:3277-84.
  30. Baron, G. S., and F. E. Nano. 1998. MglA and MglB are required for the intramacrophage growth of *Francisella novicida*. *Molecular Microbiology* 29:247-259.
  31. Barzu, S., Z. Benjelloun-Touimi, A. Phalipon, P. Sansonetti, and C. Parsot. 1997. Functional analysis of the *Shigella flexneri* IpaC invasin by insertional mutagenesis. *Infect Immun* 65:1599-605.
  32. Beauregard, K. E., K. D. Lee, R. J. Collier, and J. A. Swanson. 1997. pH-dependent perforation of macrophage phagosomes by listeriolysin O from *Listeria monocytogenes*. *J Exp Med* 186:1159-63.

33. Beron, W., C. Alvarez-Dominguez, L. Mayorga, and P. D. Stahl. 1995. Membrane trafficking along the phagocytic pathway. *Trends Cell Biol* 5:100-4.
34. Beron, W., M. G. Gutierrez, M. Rabinovitch, and M. I. Colombo. 2002. *Coxiella burnetii* localizes in a Rab7-labeled compartment with autophagic characteristics. *Infect Immun* 70:5816-21.
35. Bestwick, C. S., M. H. Bennett, and J. W. Mansfield. 1995. Hrp Mutant of *Pseudomonas syringae pv phaseolicola* Induces Cell Wall Alterations but Not Membrane Damage Leading to the Hypersensitive Reaction in Lettuce. *Plant Physiol* 108:503-516.
36. Bibeau-Poirier, A., and M. J. Servant. 2008. Roles of ubiquitination in pattern-recognition receptors and type I interferon receptor signaling. *Cytokine* 43:359-67.
37. Bingle, L. E., C. M. Bailey, and M. J. Pallen. 2008. Type VI secretion: a beginner's guide. *Curr Opin Microbiol* 11:3-8.
38. Blander, J. M., and R. Medzhitov. 2004. Regulation of phagosome maturation by signals from toll-like receptors. *Science* 304:1014-8.
39. Bliska, J. B. 2006. *Yersinia* inhibits host signaling by acetylating MAPK kinases. *ACS Chem Biol* 1:349-51.
40. Bochtler, M., L. Ditzel, M. Groll, C. Hartmann, and R. Huber. 1999. The proteasome. *Annu Rev Biophys Biomol Struct* 28:295-317.
41. Bolger, C. E., C. A. Forestal, J. K. Italo, J. L. Benach, and M. B. Furie. 2005. The live vaccine strain of *Francisella tularensis* replicates in human and murine macrophages but induces only the human cells to secrete proinflammatory cytokines. *J Leukoc Biol* 77:893-7.
42. Bonquist, L., H. Lindgren, I. Golovliov, T. Guina, and A. Sjostedt. 2008. MglA and Igl proteins contribute to the modulation of *Francisella tularensis* live vaccine strain-containing phagosomes in murine macrophages. *Infect Immun* 76:3502-10.
43. Booth, J. W., M. K. Kim, A. Jankowski, A. D. Schreiber, and S. Grinstein. 2002. Contrasting requirements for ubiquitylation during Fc receptor-mediated endocytosis and phagocytosis. *Embo J* 21:251-8.
44. Borella, P., E. Guerrieri, I. Marchesi, M. Bondi, and P. Messi. 2005. Water ecology of Legionella and protozoan: environmental and public health perspectives. *Biotechnol Annu Rev* 11:355-80.
45. Bosio, C. M., and S. W. Dow. 2005. *Francisella tularensis* induces aberrant activation of pulmonary dendritic cells. *J Immunol* 175:6792-801.
46. Botelho, R. J., D. J. Hackam, A. D. Schreiber, and S. Grinstein. 2000. Role of COPI in phagosome maturation. *J Biol Chem* 275:15717-27.
47. Boyer, F., G. Fichant, J. Berthod, Y. Vandenbrouck, and I. Attree. 2009. Dissecting the bacterial type VI secretion system by a genome wide in silico analysis: what can be learned from available microbial genomic resources? *BMC Genomics* 10:104.
48. Brawn, L. C., R. D. Hayward, and V. Koronakis. 2007. Salmonella SPI1 effector SipA persists after entry and cooperates with a SPI2 effector to regulate phagosome maturation and intracellular replication. *Cell Host Microbe* 1:63-75.

49. Brombacher, E., S. Urwyler, C. Ragaz, S. S. Weber, K. Kami, M. Overduin, and H. Hilbi. 2009. Rab1 guanine nucleotide exchange factor SidM is a major phosphatidylinositol 4-phosphate-binding effector protein of *Legionella pneumophila*. *J Biol Chem* 284:4846-56.
50. Brotcke, A., and D. M. Monack. 2008. Identification of fevR, a novel regulator of virulence gene expression in *Francisella novicida*. *Infect Immun* 76:3473-80.
51. Brotcke, A., D. S. Weiss, C. C. Kim, P. Chain, S. Malfatti, E. Garcia, and D. M. Monack. 2006. Identification of MglA-regulated genes reveals novel virulence factors in *Francisella tularensis*. *Infect Immun* 74:6642-55.
52. Brummell, J. H., D. L. Goosney, and B. B. Finlay. 2002. SifA, a type III secreted effector of *Salmonella typhimurium*, directs *Salmonella*-induced filament (Sif) formation along microtubules. *Traffic* 3:407-15.
53. Brummell, J. H., P. Tang, S. D. Mills, and B. B. Finlay. 2001. Characterization of *Salmonella*-induced filaments (Sifs) reveals a delayed interaction between *Salmonella*-containing vacuoles and late endocytic compartments. *Traffic* 2:643-53.
54. Brummell, J. H., P. Tang, M. L. Zaharik, and B. B. Finlay. 2002. Disruption of the *Salmonella*-containing vacuole leads to increased replication of *Salmonella enterica* serovar typhimurium in the cytosol of epithelial cells. *Infect Immun* 70:3264-70.
55. Bryant, P. W., A. M. Lennon-Dumenil, E. Fiebigler, C. Lagaudriere-Gesbert, and H. L. Ploegh. 2002. Proteolysis and antigen presentation by MHC class II molecules. *Adv Immunol* 80:71-114.
56. Bucci, C., R. G. Parton, I. H. Mather, H. Stunnenberg, K. Simons, B. Hoflack, and M. Zerial. 1992. The small GTPase rab5 functions as a regulatory factor in the early endocytic pathway. *Cell* 70:715-28.
57. Bucci, C., P. Thomsen, P. Nicoziani, J. McCarthy, and B. van Deurs. 2000. Rab7: a key to lysosome biogenesis. *Mol Biol Cell* 11:467-80.
58. Buchan, B. W., R. L. McCaffrey, S. R. Lindemann, L. A. Allen, and B. D. Jones. 2009. Identification of migR, a regulatory element of the *Francisella tularensis* live vaccine strain iglABCD virulence operon required for normal replication and trafficking in macrophages. *Infect Immun* 77:2517-29.
59. Bujny, M. V., P. A. Ewels, S. Humphrey, N. Attar, M. A. Jepson, and P. J. Cullen. 2008. Sorting nexin-1 defines an early phase of *Salmonella*-containing vacuole-remodeling during *Salmonella* infection. *J Cell Sci* 121:2027-36.
60. Butchar, J. P., T. J. Cremer, C. D. Clay, M. A. Gavrilin, M. D. Wewers, C. B. Marsh, L. S. Schlesinger, and S. Tridandapani. 2008. Microarray analysis of human monocytes infected with *Francisella tularensis* identifies new targets of host response subversion. *PLoS One* 3:e2924.
61. Callaghan, J., S. Nixon, C. Bucci, B. H. Toh, and H. Stenmark. 1999. Direct interaction of EEA1 with Rab5b. *Eur J Biochem* 265:361-6.
62. Callaghan, J., A. Simonsen, J. M. Gaullier, B. H. Toh, and H. Stenmark. 1999. The endosome fusion regulator early-endosomal autoantigen 1 (EEA1) is a dimer. *Biochem J* 338 ( Pt 2):539-43.
63. Camilli, A., L. G. Tilney, and D. A. Portnoy. 1993. Dual roles of plcA in *Listeria monocytogenes* pathogenesis. *Mol Microbiol* 8:143-57.

64. Cantalupo, G., P. Alifano, V. Roberti, C. B. Bruni, and C. Bucci. 2001. Rab-interacting lysosomal protein (RILP): the Rab7 effector required for transport to lysosomes. *Embo J* 20:683-93.
65. Capo, C., F. P. Lindberg, S. Meconi, Y. Zaffran, G. Tardei, E. J. Brown, D. Raoult, and J. L. Mege. 1999. Subversion of monocyte functions by coxiella burnetii: impairment of the cross-talk between alphavbeta3 integrin and CR3. *J Immunol* 163:6078-85.
66. Carter, R. S., K. N. Pennington, B. J. Ungurait, P. Arrate, and D. W. Ballard. 2003. Signal-induced ubiquitination of I kappaB Kinase-beta. *J Biol Chem* 278:48903-6.
67. Cascales, E., and P. J. Christie. 2004. Agrobacterium VirB10, an ATP energy sensor required for type IV secretion. *Proc Natl Acad Sci U S A* 101:17228-33.
68. Censini, S., C. Lange, Z. Xiang, J. E. Crabtree, P. Ghiara, M. Borodovsky, R. Rappuoli, and A. Covacci. 1996. cag, a pathogenicity island of Helicobacter pylori, encodes type I-specific and disease-associated virulence factors. *Proc Natl Acad Sci U S A* 93:14648-53.
69. Charity, J. C., L. T. Blalock, M. M. Costante-Hamm, D. L. Kasper, and S. L. Dove. 2009. Small molecule control of virulence gene expression in Francisella tularensis. *PLoS Pathog* 5:e1000641.
70. Charity, J. C., M. M. Costante-Hamm, E. L. Balon, D. H. Boyd, E. J. Rubin, and S. L. Dove. 2007. Twin RNA polymerase-associated proteins control virulence gene expression in Francisella tularensis. *PLoS Pathog* 3:e84.
71. Checroun, C., T. D. Wehrly, E. R. Fischer, S. F. Hayes, and J. Celli. 2006. Autophagy-mediated reentry of Francisella tularensis into the endocytic compartment after cytoplasmic replication. *Proc Natl Acad Sci U S A* 103:14578-83.
72. Chen, W., R. Kuolee, J. W. Austin, H. Shen, Y. Che, and J. W. Conlan. 2005. Low dose aerosol infection of mice with virulent type A Francisella tularensis induces severe thymus atrophy and CD4+CD8+ thymocyte depletion. *Microb Pathog* 39:189-96.
73. Chen, W., R. KuoLee, H. Shen, and J. W. Conlan. 2004. Susceptibility of immunodeficient mice to aerosol and systemic infection with virulent strains of Francisella tularensis. *Microb Pathog* 36:311-8.
74. Cheng, L. W., J. P. Viala, N. Stuurman, U. Wiedemann, R. D. Vale, and D. A. Portnoy. 2005. Use of RNA interference in Drosophila S2 cells to identify host pathways controlling compartmentalization of an intracellular pathogen. *Proc Natl Acad Sci U S A* 102:13646-51.
75. Child, R., T. D. Wehrly, D. Rockx-Brouwer, D. W. Dorward, and J. Celli. 2009. Acid phosphatases do not contribute to pathogenesis of Type A Francisella tularensis. *Infect Immun*.
76. Chong, A., T. D. Wehrly, V. Nair, E. R. Fischer, J. R. Barker, K. E. Klose, and J. Celli. 2008. The early phagosomal stage of Francisella tularensis determines optimal phagosomal escape and Francisella pathogenicity island protein expression. *Infect Immun* 76:5488-99.

77. Christoforidis, S., H. M. McBride, R. D. Burgoyne, and M. Zerial. 1999. The Rab5 effector EEA1 is a core component of endosome docking. *Nature* 397:621-5.
78. Christoforidis, S., M. Miaczynska, K. Ashman, M. Wilm, L. Zhao, S. C. Yip, M. D. Waterfield, J. M. Backer, and M. Zerial. 1999. Phosphatidylinositol-3-OH kinases are Rab5 effectors. *Nat Cell Biol* 1:249-52.
79. Cirillo, D. M., R. H. Valdivia, D. M. Monack, and S. Falkow. 1998. Macrophage-dependent induction of the Salmonella pathogenicity island 2 type III secretion system and its role in intracellular survival. *Mol Microbiol* 30:175-88.
80. Citovsky, V., A. Kapelnikov, S. Oliel, N. Zakai, M. R. Rojas, R. L. Gilbertson, T. Tzfira, and A. Loyter. 2004. Protein interactions involved in nuclear import of the Agrobacterium VirE2 protein in vivo and in vitro. *J Biol Chem* 279:29528-33.
81. Clarridge, J. E., 3rd, T. J. Raich, A. Sjosted, G. Sandstrom, R. O. Darouiche, R. M. Shawar, P. R. Georghiou, C. Osting, and L. Vo. 1996. Characterization of two unusual clinically significant Francisella strains. *J Clin Microbiol* 34:1995-2000.
82. Clemens, D. L., and M. A. Horwitz. 1995. Characterization of the Mycobacterium tuberculosis phagosome and evidence that phagosomal maturation is inhibited. *J Exp Med* 181:257-70.
83. Clemens, D. L., and M. A. Horwitz. 2007. Uptake and intracellular fate of Francisella tularensis in human macrophages. *Ann N Y Acad Sci* 1105:160-86.
84. Clemens, D. L., B. Y. Lee, and M. A. Horwitz. 2000. Deviant expression of Rab5 on phagosomes containing the intracellular pathogens Mycobacterium tuberculosis and Legionella pneumophila is associated with altered phagosomal fate. *Infect Immun* 68:2671-84.
85. Clemens, D. L., B. Y. Lee, and M. A. Horwitz. 2005. Francisella tularensis enters macrophages via a novel process involving pseudopod loops. *Infect Immun* 73:5892-902.
86. Clemens, D. L., B. Y. Lee, and M. A. Horwitz. 2009. Francisella tularensis phagosomal escape does not require acidification of the phagosome. *Infect Immun* 77:1757-73.
87. Clemens, D. L., B. Y. Lee, and M. A. Horwitz. 2004. Virulent and avirulent strains of Francisella tularensis prevent acidification and maturation of their phagosomes and escape into the cytoplasm in human macrophages. *Infect Immun* 72:3204-17.
88. Coburn, B., Y. Li, D. Owen, B. A. Vallance, and B. B. Finlay. 2005. Salmonella enterica serovar Typhimurium pathogenicity island 2 is necessary for complete virulence in a mouse model of infectious enterocolitis. *Infect Immun* 73:3219-27.
89. Cole, L. E., K. L. Elkins, S. M. Michalek, N. Qureshi, L. J. Eaton, P. Rallabhandi, N. Cuesta, and S. N. Vogel. 2006. Immunologic consequences of Francisella tularensis live vaccine strain infection: role of the innate immune response in infection and immunity. *J Immunol* 176:6888-99.
90. Cole, L. E., M. H. Laird, A. Seekatz, A. Santiago, Z. Jiang, E. Barry, K. A. Shirey, K. A. Fitzgerald, and S. N. Vogel. 2009. Phagosomal retention of Francisella tularensis results in TIRAP/Mal-independent TLR2 signaling. *J Leukoc Biol*.

91. Cole, L. E., A. Santiago, E. Barry, T. J. Kang, K. A. Shirey, Z. J. Roberts, K. L. Elkins, A. S. Cross, and S. N. Vogel. 2008. Macrophage proinflammatory response to *Francisella tularensis* live vaccine strain requires coordination of multiple signaling pathways. *J Immunol* 180:6885-91.
92. Cole, L. E., K. A. Shirey, E. Barry, A. Santiago, P. Rallabhandi, K. L. Elkins, A. C. Puche, S. M. Michalek, and S. N. Vogel. 2007. Toll-like receptor 2-mediated signaling requirements for *Francisella tularensis* live vaccine strain infection of murine macrophages. *Infect Immun* 75:4127-37.
93. Collazo, C. M., A. Sher, A. I. Meierovics, and K. L. Elkins. 2006. Myeloid differentiation factor-88 (MyD88) is essential for control of primary in vivo *Francisella tularensis* LVS infection, but not for control of intra-macrophage bacterial replication. *Microbes Infect* 8:779-90.
94. Collins, N. C., H. Thordal-Christensen, V. Lipka, S. Bau, E. Kombrink, J. L. Qiu, R. Huckelhoven, M. Stein, A. Freialdenhoven, S. C. Somerville, and P. Schulze-Lefert. 2003. SNARE-protein-mediated disease resistance at the plant cell wall. *Nature* 425:973-7.
95. Collins, R. F., A. D. Schreiber, S. Grinstein, and W. S. Trimble. 2002. Syntaxins 13 and 7 function at distinct steps during phagocytosis. *J Immunol* 169:3250-6.
96. Conlan, J. W., and R. J. North. 1992. Early pathogenesis of infection in the liver with the facultative intracellular bacteria *Listeria monocytogenes*, *Francisella tularensis*, and *Salmonella typhimurium* involves lysis of infected hepatocytes by leukocytes. *Infect. Immun.* 60:5164-5171.
97. Cornelis, G. R., A. Boland, A. P. Boyd, C. Geuijen, M. Iriarte, C. Neyt, M. P. Sory, and I. Stainier. 1998. The virulence plasmid of *Yersinia*, an antihost genome. *Microbiol Mol Biol Rev* 62:1315-52.
98. Cowley, S. C., C. J. Gray, and F. E. Nano. 2000. Isolation and characterization of *Francisella novicida* mutants defective in lipopolysaccharide biosynthesis. *FEMS Microbiol Lett* 182:63-7.
99. Cuellar-Mata, P., N. Jabado, J. Liu, W. Furuya, B. B. Finlay, P. Gros, and S. Grinstein. 2002. Nramp1 modifies the fusion of *Salmonella typhimurium*-containing vacuoles with cellular endomembranes in macrophages. *J Biol Chem* 277:2258-65.
100. Cunnac, S., A. Occhialini, P. Barberis, C. Boucher, and S. Genin. 2004. Inventory and functional analysis of the large Hrp regulon in *Ralstonia solanacearum*: identification of novel effector proteins translocated to plant host cells through the type III secretion system. *Mol Microbiol* 53:115-28.
101. Czajkowsky, D. M., E. M. Hotze, Z. Shao, and R. K. Tweten. 2004. Vertical collapse of a cytolysin prepore moves its transmembrane beta-hairpins to the membrane. *Embo J* 23:3206-15.
102. Dahlstrand, S., O. Ringertz, and B. Zetterberg. 1971. Airborne tularemia in Sweden. *Scand J Infect Dis* 3:7-16.
103. Dandekar, T., B. Snel, M. Huynen, and P. Bork. 1998. Conservation of gene order: a fingerprint of proteins that physically interact. *Trends Biochem Sci* 23:324-8.

104. de Bruin, O. M., J. S. Ludu, and F. E. Nano. 2007. The Francisella pathogenicity island protein IglA localizes to the bacterial cytoplasm and is needed for intracellular growth. *BMC Microbiol* 7:1.
105. De Geyter, C., B. Vogt, Z. Benjelloun-Touimi, P. J. Sansonetti, J. M. Ruyschaert, C. Parsot, and V. Cabiliaux. 1997. Purification of IpaC, a protein involved in entry of *Shigella flexneri* into epithelial cells and characterization of its interaction with lipid membranes. *FEBS Lett* 400:149-54.
106. De Geyter, C., R. Wattiez, P. Sansonetti, P. Falmagne, J. M. Ruyschaert, C. Parsot, and V. Cabiliaux. 2000. Characterization of the interaction of IpaB and IpaD, proteins required for entry of *Shigella flexneri* into epithelial cells, with a lipid membrane. *Eur J Biochem* 267:5769-76.
107. DebRoy, S., R. Thilmony, Y. B. Kwack, K. Nomura, and S. Y. He. 2004. A family of conserved bacterial effectors inhibits salicylic acid-mediated basal immunity and promotes disease necrosis in plants. *Proc Natl Acad Sci U S A* 101:9927-32.
108. Deiwick, J., T. Nikolaus, S. Erdogan, and M. Hensel. 1999. Environmental regulation of *Salmonella* pathogenicity island 2 gene expression. *Mol Microbiol* 31:1759-73.
109. Deng, K., R. J. Blick, W. Liu, and E. J. Hansen. 2006. Identification of Francisella tularensis genes affected by iron limitation. *Infect Immun* 74:4224-36.
110. Dennis, D. T., T. V. Inglesby, D. A. Henderson, J. G. Bartlett, M. S. Ascher, E. Eitzen, A. D. Fine, A. M. Friedlander, J. Hauer, M. Layton, S. R. Lillibridge, J. E. McDade, M. T. Osterholm, T. O'Toole, G. Parker, T. M. Perl, P. K. Russell, and K. Tonat. 2001. Tularemia as a biological weapon: medical and public health management. *Jama* 285:2763-73.
111. Deshaies, R. J. 1999. SCF and Cullin/Ring H2-based ubiquitin ligases. *Annu Rev Cell Dev Biol* 15:435-67.
112. Desjardins, M., L. A. Huber, R. G. Parton, and G. Griffiths. 1994. Biogenesis of phagolysosomes proceeds through a sequential series of interactions with the endocytic apparatus. *J Cell Biol* 124:677-88.
113. Desveaux, D., A. U. Singer, and J. L. Dangl. 2006. Type III effector proteins: doppelgangers of bacterial virulence. *Curr Opin Plant Biol* 9:376-82.
114. Drabick, J. J., R. B. Narayanan, J. C. Williams, J. W. Leduc, and C. A. Nacy. 1994. Passive protection of mice against lethal Francisella tularensis (live tularemia vaccine strain) infection by the sera of human recipients of the live tularemia vaccine. *Am J Med Sci* 308:83-7.
115. Dukuzumuremyi, J. M., R. Rosqvist, B. Hallberg, B. Akerstrom, H. Wolf-Watz, and K. Schesser. 2000. The Yersinia protein kinase A is a host factor inducible RhoA/Rac-binding virulence factor. *J Biol Chem* 275:35281-90.
116. Eigelsbach, H. T., and C. M. Downs. 1961. Prophylactic effectiveness of live and killed tularemia vaccines. *J. Immunol.* 87:415-425.
117. El-Etr, S. H., and J. D. Cirillo. 2001. Entry mechanisms of mycobacteria. *Front Biosci* 6:D737-47.
118. Eliasson, H., J. Lindback, J. P. Nuorti, M. Arneborn, J. Giesecke, and A. Tegnell. 2002. The 2000 tularemia outbreak: a case-control study of risk factors in disease-endemic and emergent areas, sweden. *Emerg Infect Dis* 8:956-60.

119. Elkins, K. L., C. M. Bosio, and T. R. Rhinehart-Jones. 1999. Importance of B cells, but not specific antibodies, in primary and secondary protective immunity to the intracellular bacterium *Francisella tularensis* live vaccine strain. *Infect. Immun.* 67:6002-6007.
120. Elkins, K. L., T. Rhinehart-Jones, C. A. Nacy, R. K. Winegar, and A. H. Fortier. 1993. T-cell-independent resistance to infection and generation of immunity to *Francisella tularensis*. *Infect. Immun.* 61:823-829.
121. Elkins, K. L., T. R. Rhinehart-Jones, S. J. Culkin, D. Yee, and R. K. Winegar. 1996. Minimal requirements for murine resistance to infection with *Francisella tularensis* LVS. *Infect. Immun.* 64:3288-3293.
122. Ellis, J., P. C. Oyston, M. Green, and R. W. Titball. 2002. Tularemia. *Clin Microbiol Rev* 15:631-646.
123. Ellson, C. D., K. E. Anderson, G. Morgan, E. R. Chilvers, P. Lipp, L. R. Stephens, and P. T. Hawkins. 2001. Phosphatidylinositol 3-phosphate is generated in phagosomal membranes. *Curr Biol* 11:1631-5.
124. Enderlin, G., L. Morales, R. F. Jacobs, and J. T. Cross. 1994. Streptomycin and alternative agents for the treatment of tularemia: review of the literature. *Clin Infect Dis* 19:42-7.
125. Feldman, K. A., R. E. Ensore, S. L. Lathrop, B. T. Matyas, M. McGuill, M. E. Schriefer, D. Stiles-Enos, D. T. Dennis, L. R. Petersen, and E. B. Hayes. 2001. An outbreak of primary pneumonic tularemia on Martha's Vineyard. *N Engl J Med* 345:1601-6.
126. Feng, H. M., and D. H. Walker. 2000. Mechanisms of intracellular killing of *Rickettsia conorii* in infected human endothelial cells, hepatocytes, and macrophages. *Infect Immun* 68:6729-36.
127. Feng, Y., B. Press, and A. Wandinger-Ness. 1995. Rab 7: an important regulator of late endocytic membrane traffic. *J Cell Biol* 131:1435-52.
128. Flannagan, R. S., G. Cosio, and S. Grinstein. 2009. Antimicrobial mechanisms of phagocytes and bacterial evasion strategies. *Nat Rev Microbiol* 7:355-66.
129. Forsman, M., G. Sandström, and A. Sjöstedt. 1994. Analysis of 16S ribosomal DNA sequences of *Francisella* strains and utilization for determination of the phylogeny of the genus and for identification of strains by PCR. *Internatl. J. System. Bacteriol.* 44:38-46.
130. Fortier, A. H., S. J. Green, T. Polsinelli, T. R. Jones, R. M. Crawford, D. A. Leiby, K. L. Elkins, M. S. Meltzer, and C. A. Nacy. 1994. Life and death of an intracellular pathogen: *Francisella tularensis* and the macrophage. *Immunol Ser* 60:349-61.
131. Fortier, A. H., T. Polsinelli, S. J. Green, and C. A. Nacy. 1992. Activation of macrophages for destruction of *Francisella tularensis*: identification of cytokines, effector cells, and effector molecules. *Infect. Immun.* 60:817-825.
132. Fortier, A. H., M. V. Slayter, R. Ziemba, M. S. Meltzer, and C. A. Nacy. 1991. Live vaccine strain of *Francisella tularensis*: infection and immunity in mice. *Infect. Immun.* 59::2922-2928.
133. Francis, C. L., T. A. Ryan, B. D. Jones, S. J. Smith, and S. Falkow. 1993. Ruffles induced by *Salmonella* and other stimuli direct macropinocytosis of bacteria. *Nature* 364:639-42.

134. Francis, E. 1925. Tularemia. *JAMA* 84:1243-1250.
135. Fratti, R. A., J. M. Backer, J. Gruenberg, S. Corvera, and V. Deretic. 2001. Role of phosphatidylinositol 3-kinase and Rab5 effectors in phagosomal biogenesis and mycobacterial phagosome maturation arrest. *J Cell Biol* 154:631-44.
136. Fu, Y., and J. E. Galan. 1999. A salmonella protein antagonizes Rac-1 and Cdc42 to mediate host-cell recovery after bacterial invasion. *Nature* 401:293-7.
137. Gagne, J. M., B. P. Downes, S. H. Shiu, A. M. Durski, and R. D. Vierstra. 2002. The F-box subunit of the SCF E3 complex is encoded by a diverse superfamily of genes in Arabidopsis. *Proc Natl Acad Sci U S A* 99:11519-24.
138. Gaillard, J. L., P. Berche, and P. Sansonetti. 1986. Transposon mutagenesis as a tool to study the role of hemolysin in the virulence of *Listeria monocytogenes*. *Infect Immun* 52:50-5.
139. Gal-Mor, O., and B. B. Finlay. 2006. Pathogenicity islands: a molecular toolbox for bacterial virulence. *Cell Microbiol* 8:1707-19.
140. Garcia-del Portillo, F., M. B. Zwick, K. Y. Leung, and B. B. Finlay. 1993. Intracellular replication of *Salmonella* within epithelial cells is associated with filamentous structures containing lysosomal membrane glycoproteins. *Infect Agents Dis* 2:227-31.
141. Garcia Vescovi, E., F. C. Soncini, and E. A. Groisman. 1996. Mg<sup>2+</sup> as an extracellular signal: environmental regulation of *Salmonella* virulence. *Cell* 84:165-74.
142. Gavrilin, M. A., I. J. Bouakl, N. L. Knatz, M. D. Duncan, M. W. Hall, J. S. Gunn, and M. D. Wewers. 2006. Internalization and phagosome escape required for *Francisella* to induce human monocyte IL-1 $\beta$  processing and release. *Proc Natl Acad Sci U S A* 103:141-6.
143. Geissler, E. 2005. Alibek, tularaemia, and the battle of Stalingrad. *CBW Convention Bull. September/December*:10-15.
144. Gekara, N. O., T. Jacobs, T. Chakraborty, and S. Weiss. 2005. The cholesterol-dependent cytolysin listeriolysin O aggregates rafts via oligomerization. *Cell Microbiol* 7:1345-56.
145. Gekara, N. O., and S. Weiss. 2004. Lipid rafts clustering and signalling by listeriolysin O. *Biochem Soc Trans* 32:712-4.
146. Gelvin, S. B. 2000. *Agrobacterium* and Plant Genes Involved in T-DNA Transfer and Integration. *Annu Rev Plant Physiol Plant Mol Biol* 51:223-256.
147. Genin, S., and C. Boucher. 2004. Lessons learned from the genome analysis of *Ralstonia solanacearum*. *Annu Rev Phytopathol* 42:107-34.
148. Glomski, I. J., M. M. Gedde, A. W. Tsang, J. A. Swanson, and D. A. Portnoy. 2002. The *Listeria monocytogenes* hemolysin has an acidic pH optimum to compartmentalize activity and prevent damage to infected host cells. *J Cell Biol* 156:1029-38.
149. Goldstein, G., M. Scheid, U. Hammerling, D. H. Schlesinger, H. D. Niall, and E. A. Boyse. 1975. Isolation of a polypeptide that has lymphocyte-differentiating properties and is probably represented universally in living cells. *Proc Natl Acad Sci U S A* 72:11-5.

150. Golovliov, I., V. Baranov, Z. Krocova, H. Kovarova, and A. Sjostedt. 2003. An attenuated strain of the facultative intracellular bacterium *Francisella tularensis* can escape the phagosome of monocytic cells. *Infect Immun* 71:5940-5950.
151. Golovliov, I., M. Ericsson, G. Sandström, A. Tärnvik, and A. Sjöstedt. 1997. Identification of proteins of *Francisella tularensis* induced during growth in macrophages and cloning of the gene encoding a prominently induced 23-kilodalton protein. *Infection and Immunity* 65:2183-2189.
152. Golovliov, I., K. Kuoppa, A. Sjostedt, A. Tarnvik, and G. Sandstrom. 1996. Cytokine expression in the liver of mice infected with a highly virulent strain of *Francisella tularensis*. *FEMS Immunol Med Microbiol* 13:239-44.
153. Golovliov, I., G. Sandstrom, M. Ericsson, A. Sjostedt, and A. Tarnvik. 1995. Cytokine expression in the liver during the early phase of murine tularemia. *Infect Immun* 63:534-8.
154. Gray, C. G., S. C. Cowley, K. K. Cheung, and F. E. Nano. 2002. The identification of five genetic loci of *Francisella novicida* associated with intracellular growth. *FEMS Microbiol Lett* 215:53-6.
155. Greco, D., G. Allegrini, T. Tizzi, E. Ninu, A. Lamanna, and S. Luzi. 1987. A waterborne tularemia outbreak. *Eur J Epidemiol* 3:35-8.
156. Groisman, E. A., and H. Ochman. 1993. Cognate gene clusters govern invasion of host epithelial cells by *Salmonella typhimurium* and *Shigella flexneri*. *Embo J* 12:3779-87.
157. Grosshans, B. L., D. Ortiz, and P. Novick. 2006. Rabs and their effectors: achieving specificity in membrane traffic. *Proc Natl Acad Sci U S A* 103:11821-7.
158. Gruenberg, J. 2001. The endocytic pathway: a mosaic of domains. *Nat Rev Mol Cell Biol* 2:721-30.
159. Guignot, J., E. Caron, C. Beuzon, C. Bucci, J. Kagan, C. Roy, and D. W. Holden. 2004. Microtubule motors control membrane dynamics of *Salmonella*-containing vacuoles. *J Cell Sci* 117:1033-45.
160. Gunn, J. S., and R. K. Ernst. 2007. The structure and function of *Francisella* lipopolysaccharide. *Ann N Y Acad Sci* 1105:202-18.
161. Gutierrez, M. G., C. L. Vazquez, D. B. Munafo, F. C. Zoppino, W. Beron, M. Rabinovitch, and M. I. Colombo. 2005. Autophagy induction favours the generation and maturation of the *Coxiella*-replicative vacuoles. *Cell Microbiol* 7:981-93.
162. Hacker, J., L. Bender, M. Ott, J. Wingender, B. Lund, R. Marre, and W. Goebel. 1990. Deletions of chromosomal regions coding for fimbriae and hemolysins occur in vitro and in vivo in various extraintestinal *Escherichia coli* isolates. *Microb Pathog* 8:213-25.
163. Hacker, J., G. Blum-Oehler, I. Muhldorfer, and H. Tschape. 1997. Pathogenicity islands of virulent bacteria: structure, function and impact on microbial evolution. *Mol Microbiol* 23:1089-97.
164. Hackstadt, T., D. D. Rockey, R. A. Heinzen, and M. A. Scidmore. 1996. *Chlamydia trachomatis* interrupts an exocytic pathway to acquire endogenously synthesized sphingomyelin in transit from the Golgi apparatus to the plasma membrane. *Embo J* 15:964-77.

165. Hajjar, A. M., M. D. Harvey, S. A. Shaffer, D. R. Goodlett, A. Sjostedt, H. Edebro, M. Forsman, M. Bystrom, M. Pelletier, C. B. Wilson, S. I. Miller, S. J. Skerrett, and R. K. Ernst. 2006. Lack of in vitro and in vivo recognition of *Francisella tularensis* subspecies lipopolysaccharide by Toll-like receptors. *Infect Immun* 74:6730-8.
166. Hall, J. D., R. R. Craven, J. R. Fuller, R. J. Pickles, and T. H. Kawula. 2007. *Francisella tularensis* replicates within alveolar type II epithelial cells in vitro and in vivo following inhalation. *Infect Immun* 75:1034-9.
167. Hampton, M. B., A. J. Kettle, and C. C. Winterbourn. 1998. Inside the neutrophil phagosome: oxidants, myeloperoxidase, and bacterial killing. *Blood* 92:3007-17.
168. Hansen-Wester, I., and M. Hensel. 2002. Genome-based identification of chromosomal regions specific for *Salmonella* spp. *Infect Immun* 70:2351-60.
169. Hansen-Wester, I., and M. Hensel. 2001. *Salmonella* pathogenicity islands encoding type III secretion systems. *Microbes Infect* 3:549-59.
170. Harrison, R. E., J. H. Brumell, A. Khandani, C. Bucci, C. C. Scott, X. Jiang, B. B. Finlay, and S. Grinstein. 2004. *Salmonella* impairs RILP recruitment to Rab7 during maturation of invasion vacuoles. *Mol Biol Cell* 15:3146-54.
171. Harrison, R. E., C. Bucci, O. V. Vieira, T. A. Schroer, and S. Grinstein. 2003. Phagosomes fuse with late endosomes and/or lysosomes by extension of membrane protrusions along microtubules: role of Rab7 and RILP. *Mol Cell Biol* 23:6494-506.
172. Hassoun, A., R. Spera, and J. Dunkel. 2006. Tularemia and once-daily gentamicin. *Antimicrob Agents Chemother* 50:824.
173. Hauck, P., R. Thilmony, and S. Y. He. 2003. A *Pseudomonas syringae* type III effector suppresses cell wall-based extracellular defense in susceptible *Arabidopsis* plants. *Proc Natl Acad Sci U S A* 100:8577-82.
174. Heinzen, R. A., M. A. Scidmore, D. D. Rockey, and T. Hackstadt. 1996. Differential interaction with endocytic and exocytic pathways distinguish parasitophorous vacuoles of *Coxiella burnetii* and *Chlamydia trachomatis*. *Infect Immun* 64:796-809.
175. Henry, R., L. Shaughnessy, M. J. Loessner, C. Alberti-Segui, D. E. Higgins, and J. A. Swanson. 2006. Cytolysin-dependent delay of vacuole maturation in macrophages infected with *Listeria monocytogenes*. *Cell Microbiol* 8:107-19.
176. Hensel, M., J. E. Shea, S. R. Waterman, R. Mundy, T. Nikolaus, G. Banks, A. Vazquez-Torres, C. Gleeson, F. C. Fang, and D. W. Holden. 1998. Genes encoding putative effector proteins of the type III secretion system of *Salmonella* pathogenicity island 2 are required for bacterial virulence and proliferation in macrophages. *Mol Microbiol* 30:163-74.
177. Hicke, L., and R. Dunn. 2003. Regulation of membrane protein transport by ubiquitin and ubiquitin-binding proteins. *Annu Rev Cell Dev Biol* 19:141-72.
178. Hollis, D. G., R. E. Weaver, A. G. Steigerwalt, J. D. Wenger, C. W. Moss, and D. J. Brenner. 1989. *Francisella philomiragia* comb. nov. (formerly *Yersinia philomiragia*) and *Francisella tularensis* biogroup *novicida* (formerly *Francisella novicida*) associated with human disease. *Journal of Clinical Microbiology* 27:1601-1608.

179. Hooykaas, P. J., M. Hofker, H. den Dulk-Ras, and R. A. Schilperoort. 1984. A comparison of virulence determinants in an octopine Ti plasmid, a nopaline Ti plasmid, and an Ri plasmid by complementation analysis of *Agrobacterium tumefaciens* mutants. *Plasmid* 11:195-205.
180. Hrstka, R., J. Stulik, and B. Vojtesek. 2005. The role of MAPK signal pathways during *Francisella tularensis* LVS infection-induced apoptosis in murine macrophages. *Microbes Infect* 7:619-25.
181. Huynh, K. K., E. L. Eskelinen, C. C. Scott, A. Malevanets, P. Saftig, and S. Grinstein. 2007. LAMP proteins are required for fusion of lysosomes with phagosomes. *Embo J* 26:313-24.
182. Ingmundson, A., A. Delprato, D. G. Lambright, and C. R. Roy. 2007. *Legionella pneumophila* proteins that regulate Rab1 membrane cycling. *Nature* 450:365-9.
183. Isberg, R. R., T. J. O'Connor, and M. Heidtman. 2009. The *Legionella pneumophila* replication vacuole: making a cosy niche inside host cells. *Nat Rev Microbiol* 7:13-24.
184. Ishihama, A., and T. Saitoh. 1979. Subunits of RNA polymerase in function and structure. IX. Regulation of RNA polymerase activity by stringent starvation protein (SSP). *J Mol Biol* 129:517-30.
185. Iyer, L. M., A. M. Burroughs, and L. Aravind. 2006. The prokaryotic antecedents of the ubiquitin-signaling system and the early evolution of ubiquitin-like beta-grasp domains. *Genome Biol* 7:R60.
186. Jacobs, T., A. Darji, N. Frahm, M. Rohde, J. Wehland, T. Chakraborty, and S. Weiss. 1998. Listeriolysin O: cholesterol inhibits cytolysis but not binding to cellular membranes. *Mol Microbiol* 28:1081-9.
187. Janjusevic, R., R. B. Abramovitch, G. B. Martin, and C. E. Stebbins. 2006. A bacterial inhibitor of host programmed cell death defenses is an E3 ubiquitin ligase. *Science* 311:222-6.
188. Johansson, A., S. K. Urich, M. C. Chu, A. Sjostedt, and A. Tarnvik. 2002. In vitro susceptibility to quinolones of *Francisella tularensis* subspecies *tularensis*. *Scand J Infect Dis* 34:327-30.
189. Jordens, I., M. Fernandez-Borja, M. Marsman, S. Dusseljee, L. Janssen, J. Calafat, H. Janssen, R. Wubbolts, and J. Neefjes. 2001. The Rab7 effector protein RILP controls lysosomal transport by inducing the recruitment of dynein-dynactin motors. *Curr Biol* 11:1680-5.
190. Joshi, A. D., S. Sturgill-Koszycki, and M. S. Swanson. 2001. Evidence that Dot-dependent and -independent factors isolate the *Legionella pneumophila* phagosome from the endocytic network in mouse macrophages. *Cell Microbiol* 3:99-114.
191. Juszat, H. J. 1952. Tularemia in Europe, 1926-1951. In *Welt-Suchen Atlas* 1:7-16.
192. Kanai, F., H. Liu, S. J. Field, H. Akbary, T. Matsuo, G. E. Brown, L. C. Cantley, and M. B. Yaffe. 2001. The PX domains of p47phox and p40phox bind to lipid products of PI(3)K. *Nat Cell Biol* 3:675-8.
193. Kathariou, S., P. Metz, H. Hof, and W. Goebel. 1987. Tn916-induced mutations in the hemolysin determinant affecting virulence of *Listeria monocytogenes*. *J Bacteriol* 169:1291-7.

194. Katz, J., P. Zhang, M. Martin, S. N. Vogel, and S. M. Michalek. 2006. Toll-like receptor 2 is required for inflammatory responses to *Francisella tularensis* LVS. *Infect Immun* 74:2809-16.
195. Kawula, T. H., J. D. Hall, J. R. Fuller, and R. R. Craven. 2004. Use of transposon-transposase complexes to create stable insertion mutant strains of *Francisella tularensis* LVS. *Appl Environ Microbiol* 70:6901-4.
196. Kerscher, O., R. Felberbaum, and M. Hochstrasser. 2006. Modification of proteins by ubiquitin and ubiquitin-like proteins. *Annu Rev Cell Dev Biol* 22:159-80.
197. Kieffer, T. L., S. Cowley, F. E. Nano, and K. L. Elkins. 2003. *Francisella novicida* LPS has greater immunobiological activity in mice than *F. tularensis* LPS, and contributes to *F. novicida* murine pathogenesis. *Microbes Infect* 5:397-403.
198. Kim, D. W., G. Lenzen, A. L. Page, P. Legrain, P. J. Sansonetti, and C. Parsot. 2005. The *Shigella flexneri* effector OspG interferes with innate immune responses by targeting ubiquitin-conjugating enzymes. *Proc Natl Acad Sci U S A* 102:14046-51.
199. Kim, Y. J., N. C. Lin, and G. B. Martin. 2002. Two distinct *Pseudomonas* effector proteins interact with the Pto kinase and activate plant immunity. *Cell* 109:589-98.
200. Kipreos, E. T., and M. Pagano. 2000. The F-box protein family. *Genome Biol* 1:REVIEWS3002.
201. Koskela, P., and A. Salminen. 1985. Humoral immunity against *Francisella tularensis* after natural infection. *J Clin Microbiol* 22:973-9.
202. Kostyuchenko, V. A., P. R. Chipman, P. G. Leiman, F. Arisaka, V. V. Mesyanzhinov, and M. G. Rossmann. 2005. The tail structure of bacteriophage T4 and its mechanism of contraction. *Nat Struct Mol Biol* 12:810-3.
203. Kubori, T., and J. E. Galan. 2003. Temporal regulation of salmonella virulence effector function by proteasome-dependent protein degradation. *Cell* 115:333-42.
204. Kumar, A., and J. V. Palletta. 1998. An additional role for the F-box motif: gene regulation within the *Neurospora crassa* sulfur control network. *Proc Natl Acad Sci U S A* 95:2417-22.
205. Kwiatkowska, K., and A. Sobota. 1999. Signaling pathways in phagocytosis. *Bioessays* 21:422-31.
206. Lai, X. H., I. Golovliov, and A. Sjostedt. 2004. Expression of IglC is necessary for intracellular growth and induction of apoptosis in murine macrophages by *Francisella tularensis*. *Microb Pathog* 37:225-30.
207. Lai, X. H., I. Golovliov, and A. Sjostedt. 2001. *Francisella tularensis* induces cytopathogenicity and apoptosis in murine macrophages via a mechanism that requires intracellular bacterial multiplication. *Infect Immun* 69:4691-4.
208. Lai, X. H., and A. Sjostedt. 2003. Delineation of the molecular mechanisms of *Francisella tularensis*-induced apoptosis in murine macrophages. *Infect Immun* 71:4642-6.
209. Larsson, P., P. C. Oyston, P. Chain, M. C. Chu, M. Duffield, H. H. Fuxelius, E. Garcia, G. Halltorp, D. Johansson, K. E. Isherwood, P. D. Karp, E. Larsson, Y. Liu, S. Michell, J. Prior, R. Prior, S. Malfatti, A. Sjostedt, K. Svensson, N.

- Thompson, L. Vergez, J. K. Wagg, B. W. Wren, L. E. Lindler, S. G. Andersson, M. Forsman, and R. W. Titball. 2005. The complete genome sequence of *Francisella tularensis*, the causative agent of tularemia. *Nat. Genet.* 37:153-159.
210. Lauriano, C. M., J. R. Barker, S.-S. Yoon, F. E. Nano, B. P. Arulanandam, D. J. Hassett, and K. E. Klose. 2004. MglA regulates transcription of virulence factors necessary for *Francisella tularensis* intraamoebae and intramacrophage survival. *Proc Natl Acad Sci U S A* 101:4246-4249.
211. Lawe, D. C., V. Patki, R. Heller-Harrison, D. Lambright, and S. Corvera. 2000. The FYVE domain of early endosome antigen 1 is required for both phosphatidylinositol 3-phosphate and Rab5 binding. Critical role of this dual interaction for endosomal localization. *J Biol Chem* 275:3699-705.
212. Lee, W. L., M. K. Kim, A. D. Schreiber, and S. Grinstein. 2005. Role of ubiquitin and proteasomes in phagosome maturation. *Mol Biol Cell* 16:2077-90.
213. Leiby, D. A., A. H. Fortier, R. M. Crawford, R. D. Schreiber, and C. A. Nacy. 1992. In vivo modulation of the murine immune response to *Francisella tularensis* LVS by administration of anticytokine antibodies. *Infect Immun* 60:84-9.
214. Lenco, J., M. Hubalek, P. Larsson, A. Fucikova, M. Brychta, A. Macela, and J. Stulik. 2007. Proteomics analysis of the *Francisella tularensis* LVS response to iron restriction: induction of the *F. tularensis* pathogenicity island proteins IglABC. *FEMS Microbiol Lett* 269:11-21.
215. Lennartz, M. R. 1999. Phospholipases and phagocytosis: the role of phospholipid-derived second messengers in phagocytosis. *Int J Biochem Cell Biol* 31:415-30.
216. Lennon-Dumenil, A. M., A. H. Bakker, R. Maehr, E. Fiebigler, H. S. Overkleeft, M. Roseblatt, H. L. Ploegh, and C. Lagaudriere-Gesbert. 2002. Analysis of protease activity in live antigen-presenting cells shows regulation of the phagosomal proteolytic contents during dendritic cell activation. *J Exp Med* 196:529-40.
217. Li, H., S. Nookala, X. R. Bina, J. E. Bina, and F. Re. 2006. Innate immune response to *Francisella tularensis* is mediated by TLR2 and caspase-1 activation. *J Leukoc Biol* 80:766-73.
218. Lindgren, H., I. Golovliov, V. Baranov, R. K. Ernst, M. Telepnev, and A. Sjostedt. 2004. Factors affecting the escape of *Francisella tularensis* from the phagolysosome. *J Med Microbiol* 53:953-8.
219. Lindgren, H., L. Stenman, A. Tarnvik, and A. Sjostedt. 2005. The contribution of reactive nitrogen and oxygen species to the killing of *Francisella tularensis* LVS by murine macrophages. *Microbes Infect* 7:467-75.
220. Littleton, J. T., R. J. Barnard, S. A. Titus, J. Slind, E. R. Chapman, and B. Ganetzky. 2001. SNARE-complex disassembly by NSF follows synaptic-vesicle fusion. *Proc Natl Acad Sci U S A* 98:12233-8.
221. Ludu, J. S., O. M. de Bruin, B. N. Duplantis, C. L. Schmerk, A. Y. Chou, K. L. Elkins, and F. E. Nano. 2008. The *Francisella* pathogenicity island protein PdpD is required for full virulence and associates with homologues of the type VI secretion system. *J Bacteriol* 190:4584-95.
222. Ludu, J. S., E. B. Nix, B. N. Duplantis, O. M. de Bruin, L. A. Gallagher, L. M. Hawley, and F. E. Nano. 2008. Genetic elements for selection, deletion

- mutagenesis and complementation in *Francisella* spp. *FEMS Microbiol Lett* 278:86-93.
223. Machesky, L. M., and R. C. May. 2001. Arps: actin-related proteins. *Results Probl Cell Differ* 32:213-29.
  224. Machner, M. P., and R. R. Isberg. 2007. A bifunctional bacterial protein links GDI displacement to Rab1 activation. *Science* 318:974-7.
  225. Machner, M. P., and R. R. Isberg. 2006. Targeting of host Rab GTPase function by the intravacuolar pathogen *Legionella pneumophila*. *Dev Cell* 11:47-56.
  226. Maier, T. M., M. S. Casey, R. H. Becker, C. W. Dorsey, E. M. Glass, N. Maltsev, T. C. Zahrt, and D. W. Frank. 2007. Identification of *Francisella tularensis* Himar1-based transposon mutants defective for replication in macrophages. *Infect Immun* 75:5376-89.
  227. Mallo, G. V., M. Espina, A. C. Smith, M. R. Terebiznik, A. Aleman, B. B. Finlay, L. E. Rameh, S. Grinstein, and J. H. Brumell. 2008. SopB promotes phosphatidylinositol 3-phosphate formation on *Salmonella* vacuoles by recruiting Rab5 and Vps34. *J Cell Biol* 182:741-52.
  228. Marcus, S. L., L. A. Knodler, and B. B. Finlay. 2002. *Salmonella enterica* serovar Typhimurium effector SigD/SopB is membrane-associated and ubiquitinated inside host cells. *Cell Microbiol* 4:435-46.
  229. Marquis, H., and E. J. Hager. 2000. pH-regulated activation and release of a bacteria-associated phospholipase C during intracellular infection by *Listeria monocytogenes*. *Mol Microbiol* 35:289-98.
  230. Marsman, M., I. Jordens, C. Kuijl, L. Janssen, and J. Neefjes. 2004. Dynein-mediated vesicle transport controls intracellular *Salmonella* replication. *Mol Biol Cell* 15:2954-64.
  231. Mattinen, L., R. Nissinen, T. Riipi, N. Kalkkinen, and M. Pirhonen. 2007. Host-extract induced changes in the secretome of the plant pathogenic bacterium *Pectobacterium atrosepticum*. *Proteomics* 7:3527-37.
  232. Maurin, M., A. M. Benoliel, P. Bongrand, and D. Raoult. 1992. Phagolysosomes of *Coxiella burnetii*-infected cell lines maintain an acidic pH during persistent infection. *Infect Immun* 60:5013-6.
  233. McBride, H. M., V. Rybin, C. Murphy, A. Giner, R. Teasdale, and M. Zerial. 1999. Oligomeric complexes link Rab5 effectors with NSF and drive membrane fusion via interactions between EEA1 and syntaxin 13. *Cell* 98:377-86.
  234. McCaffrey, R. L., and L. A. Allen. 2006. *Francisella tularensis* LVS evades killing by human neutrophils via inhibition of the respiratory burst and phagosome escape. *J Leukoc Biol* 80:1224-30.
  235. McCoy, G. W., and C. W. Chapin. 1912. Further observations on a plague like disease of rodents with a preliminary note on the causative agent *bacterium tularense*. *J. Infect. Dis.* 10:61-72.
  236. McLeod, M. P., X. Qin, S. E. Karpathy, J. Gioia, S. K. Highlander, G. E. Fox, T. Z. McNeill, H. Jiang, D. Muzny, L. S. Jacob, A. C. Hawes, E. Sodergren, R. Gill, J. Hume, M. Morgan, G. Fan, A. G. Amin, R. A. Gibbs, C. Hong, X. J. Yu, D. H. Walker, and G. M. Weinstock. 2004. Complete genome sequence of *Rickettsia typhi* and comparison with sequences of other rickettsiae. *J Bacteriol* 186:5842-55.

237. Mdluli, K. E., L. S. Anthony, G. S. Baron, M. K. McDonald, S. V. Myltseva, and F. E. Nano. 1994. Serum-sensitive mutation of *Francisella novicida*: association with an ABC transporter gene. *Microbiology* 140:3309-18.
238. Meconi, S., V. Giacomo, P. Boquet, D. Raoult, J. L. Mege, and C. Capo. 1998. *Coxiella burnetii* induces reorganization of the actin cytoskeleton in human monocytes. *Infect Immun* 66:5527-33.
239. Melchers, L. S., M. J. Maroney, A. den Dulk-Ras, D. V. Thompson, H. A. van Vuuren, R. A. Schilperoort, and P. J. Hooykaas. 1990. Octopine and nopaline strains of *Agrobacterium tumefaciens* differ in virulence; molecular characterization of the *virF* locus. *Plant Mol Biol* 14:249-59.
240. Memon, A. R. 2004. The role of ADP-ribosylation factor and SAR1 in vesicular trafficking in plants. *Biochim Biophys Acta* 1664:9-30.
241. Menard, R., P. J. Sansonetti, and C. Parsot. 1993. Nonpolar mutagenesis of the *ipa* genes defines *IpaB*, *IpaC*, and *IpaD* as effectors of *Shigella flexneri* entry into epithelial cells. *J Bacteriol* 175:5899-906.
242. Meresse, S., O. Steele-Mortimer, B. B. Finlay, and J. P. Gorvel. 1999. The rab7 GTPase controls the maturation of *Salmonella typhimurium*-containing vacuoles in HeLa cells. *Embo J* 18:4394-403.
243. Mertens, K., L. Lantsheer, D. G. Ennis, and J. E. Samuel. 2008. Constitutive SOS expression and damage-inducible AddAB-mediated recombinational repair systems for *Coxiella burnetii* as potential adaptations for survival within macrophages. *Mol Microbiol* 69:1411-26.
244. Miller, S. I., R. K. Ernst, and M. W. Bader. 2005. LPS, TLR4 and infectious disease diversity. *Nat Rev Microbiol* 3:36-46.
245. Mills, I. G., S. Urbe, and M. J. Clague. 2001. Relationships between EEA1 binding partners and their role in endosome fusion. *J Cell Sci* 114:1959-65.
246. Mills, S. D., A. Boland, M. P. Sory, P. van der Smissen, C. Kerbouch, B. B. Finlay, and G. R. Cornelis. 1997. *Yersinia enterocolitica* induces apoptosis in macrophages by a process requiring functional type III secretion and translocation mechanisms and involving YopP, presumably acting as an effector protein. *Proc Natl Acad Sci U S A* 94:12638-43.
247. Miold, S., K. Ehrbar, A. Weissmuller, R. Prager, H. Tschape, H. Russmann, and W. D. Hardt. 2001. *Salmonella* host cell invasion emerged by acquisition of a mosaic of separate genetic elements, including *Salmonella* pathogenicity island 1 (SPI1), SPI5, and *sopE2*. *J Bacteriol* 183:2348-58.
248. Misra, S., G. J. Miller, and J. H. Hurley. 2001. Recognizing phosphatidylinositol 3-phosphate. *Cell* 107:559-62.
249. Mittal, R., S. Y. Peak-Chew, and H. T. McMahon. 2006. Acetylation of MEK2 and I kappa B kinase (IKK) activation loop residues by YopJ inhibits signaling. *Proc Natl Acad Sci U S A* 103:18574-9.
250. Miyake, K. 2004. Endotoxin recognition molecules, Toll-like receptor 4-MD-2. *Semin Immunol* 16:11-6.
251. Mohapatra, N. P., A. Balagopal, S. Soni, L. S. Schlesinger, and J. S. Gunn. 2007. *AcpA* is a *Francisella* acid phosphatase that affects intramacrophage survival and virulence. *Infect Immun* 75:390-6.

252. Mohapatra, N. P., S. Soni, B. L. Bell, R. Warren, R. K. Ernst, A. Muszynski, R. W. Carlson, and J. S. Gunn. 2007. Identification of an orphan response regulator required for the virulence of *Francisella* spp. and transcription of pathogenicity island genes. *Infect Immun* 75:3305-14.
253. Mohapatra, N. P., S. Soni, T. J. Reilly, J. Liu, K. E. Klose, and J. S. Gunn. 2008. Combined deletion of four *Francisella novicida* acid phosphatases attenuates virulence and macrophage vacuolar escape. *Infect Immun* 76:3690-9.
254. Monack, D. M., J. Mecsas, N. Ghori, and S. Falkow. 1997. *Yersinia* signals macrophages to undergo apoptosis and YopJ is necessary for this cell death. *Proc Natl Acad Sci U S A* 94:10385-90.
255. Mougous, J. D., M. E. Cuff, S. Raunser, A. Shen, M. Zhou, C. A. Gifford, A. L. Goodman, G. Joachimiak, C. L. Ordenez, S. Lory, T. Walz, A. Joachimiak, and J. J. Mekalanos. 2006. A virulence locus of *Pseudomonas aeruginosa* encodes a protein secretion apparatus. *Science* 312:1526-30.
256. Mukherjee, K., S. A. Siddiqi, S. Hashim, M. Raje, S. K. Basu, and A. Mukhopadhyay. 2000. Live *Salmonella* recruits N-ethylmaleimide-sensitive fusion protein on phagosomal membrane and promotes fusion with early endosome. *J Cell Biol* 148:741-53.
257. Mukherjee, S., R. N. Ghosh, and F. R. Maxfield. 1997. Endocytosis. *Physiol Rev* 77:759-803.
258. Mukherjee, S., G. Keitany, Y. Li, Y. Wang, H. L. Ball, E. J. Goldsmith, and K. Orth. 2006. *Yersinia* YopJ acetylates and inhibits kinase activation by blocking phosphorylation. *Science* 312:1211-4.
259. Murata, T., A. Delprato, A. Ingmundson, D. K. Toomre, D. G. Lambright, and C. R. Roy. 2006. The *Legionella pneumophila* effector protein DrrA is a Rab1 guanine nucleotide-exchange factor. *Nat Cell Biol* 8:971-7.
260. Nagai, H., J. C. Kagan, X. Zhu, R. A. Kahn, and C. R. Roy. 2002. A bacterial guanine nucleotide exchange factor activates ARF on *Legionella* phagosomes. *Science* 295:679-82.
261. Nano, F. E. 1988. Identification of a heat-modifiable protein of *Francisella tularensis* and molecular cloning of the encoding gene. *Microb Pathog* 5:109-19.
262. Nano, F. E., and C. Schmerk. 2007. The *Francisella* pathogenicity island. *Ann N Y Acad Sci* 1105:122-37.
263. Nano, F. E., N. Zhang, S. C. Cowley, K. E. Klose, K. K. M. Cheung, M. J. Roberts, J. S. Ludu, G. W. Letendre, A. I. Meierovics, G. Stephens, and K. L. Elkins. 2004. A *Francisella tularensis* Pathogenicity Island Required for Intramacrophage Growth. *J. Bacteriol.* 186:6430-6436.
264. Nawabi, P., D. M. Catron, and K. Haldar. 2008. Esterification of cholesterol by a type III secretion effector during intracellular *Salmonella* infection. *Mol Microbiol* 68:173-85.
265. Nijman, S. M., T. T. Huang, A. M. Dirac, T. R. Brummelkamp, R. M. Kerkhoven, A. D. D'Andrea, and R. Bernards. 2005. The deubiquitinating enzyme USP1 regulates the Fanconi anemia pathway. *Mol Cell* 17:331-9.
266. Nix, E. B., K. K. Cheung, D. Wang, N. Zhang, R. D. Burke, and F. E. Nano. 2006. Virulence of *Francisella* spp. in chicken embryos. *Infect Immun* 74:4809-16.

267. Nomura, K., S. Debroy, Y. H. Lee, N. Pumpilin, J. Jones, and S. Y. He. 2006. A bacterial virulence protein suppresses host innate immunity to cause plant disease. *Science* 313:220-3.
268. Norris, F. A., M. P. Wilson, T. S. Wallis, E. E. Galyov, and P. W. Majerus. 1998. SopB, a protein required for virulence of *Salmonella dublin*, is an inositol phosphate phosphatase. *Proc Natl Acad Sci U S A* 95:14057-9.
269. Ochman, H., F. C. Soncini, F. Solomon, and E. A. Groisman. 1996. Identification of a pathogenicity island required for *Salmonella* survival in host cells. *Proc Natl Acad Sci U S A* 93:7800-4.
270. Ohara, Y., T. Sato, and M. Homma. 1998. Arthropod-borne tularemia in Japan: clinical analysis of 1,374 cases observed between 1924 and 1996. *J Med Entomol* 35:471-3.
271. Ohlson, M. B., K. Fluhr, C. L. Birmingham, J. H. Brumell, and S. I. Miller. 2005. SseJ deacylase activity by *Salmonella enterica* serovar Typhimurium promotes virulence in mice. *Infect Immun* 73:6249-59.
272. Olsufiev, N. G., O. S. Emelyanova, and T. N. Dunayeva. 1959. Comparative study of strains of *B. tularensis* in the old and new world and their taxonomy. *J Hyg Epidemiol Microbiol Immunol* 3:138-49.
273. Olsufjev, J. G., and I. S. Meshcheryakova. 1983. Subspecific taxonomy of *Francisella tularensis* McCoy and Chapin 1912. *Int. J. Syst. Bacteriol.* 33:872-874.
274. Olsufjev, N. G. 1970. Taxonomy and characteristic of the genus *Francisella* Dorofeev, 1947. *J Hyg Epidemiol Microbiol Immunol* 14:67-74.
275. Olsufviev, N. G. 1977. Results and perspectives of the study of natural foci of tularemia in USSR. *Med Parazitol.* 46:273-282.
276. Orth, K. 2002. Function of the *Yersinia* effector YopJ. *Curr Opin Microbiol* 5:38-43.
277. Orth, K., L. E. Palmer, Z. Q. Bao, S. Stewart, A. E. Rudolph, J. B. Bliska, and J. E. Dixon. 1999. Inhibition of the mitogen-activated protein kinase kinase superfamily by a *Yersinia* effector. *Science* 285:1920-3.
278. Osborn, M. J., J. E. Gander, E. Parisi, and J. Carson. 1972. Mechanism of assembly of the outer membrane of *Salmonella typhimurium*. Isolation and characterization of cytoplasmic and outer membrane. *J Biol Chem* 247:3962-72.
279. Ou, H. Y., L. L. Chen, J. Lonnen, R. R. Chaudhuri, A. B. Thani, R. Smith, N. J. Garton, J. Hinton, M. Pallen, M. R. Barer, and K. Rajakumar. 2006. A novel strategy for the identification of genomic islands by comparative analysis of the contents and contexts of tRNA sites in closely related bacteria. *Nucleic Acids Res* 34:e3.
280. Oyston, P. C. 2009. *Francisella tularensis* vaccines. *Vaccine* 27 Suppl 4:D48-51.
281. Oyston, P. C., A. Sjostedt, and R. W. Titball. 2004. Tularaemia: bioterrorism defence renews interest in *Francisella tularensis*. *Nat Rev Microbiol* 2:967-78.
282. Page, A. L., H. Ohayon, P. J. Sansonetti, and C. Parsot. 1999. The secreted IpaB and IpaC invasins and their cytoplasmic chaperone IpgC are required for intercellular dissemination of *Shigella flexneri*. *Cell Microbiol* 1:183-93.
283. Pammit, M. A., V. N. Budhavarapu, E. K. Raulie, K. E. Klose, J. M. Teale, and B. P. Arulanandam. 2004. Intranasal interleukin-12 treatment promotes antimicrobial

- clearance and survival in pulmonary *Francisella tularensis* subsp. *novicida* infection. *Antimicrob Agents Chemother* 48:4513-9.
284. Pan, X., A. Luhrmann, A. Satoh, M. A. Laskowski-Arce, and C. R. Roy. 2008. Ankyrin repeat proteins comprise a diverse family of bacterial type IV effectors. *Science* 320:1651-4.
285. Panaretou, C., J. Domin, S. Cockcroft, and M. D. Waterfield. 1997. Characterization of p150, an adaptor protein for the human phosphatidylinositol (PtdIns) 3-kinase. Substrate presentation by phosphatidylinositol transfer protein to the p150.Ptdins 3-kinase complex. *J Biol Chem* 272:2477-85.
286. Paranavitana, C., P. R. Pittman, M. Velauthapillai, E. Zelazowska, and L. Dasilva. 2008. Transcriptional profiling of *Francisella tularensis* infected peripheral blood mononuclear cells: a predictive tool for tularemia. *FEMS Immunol Med Microbiol* 54:92-103.
287. Pasetti, M. F., L. Cuberos, T. L. Horn, J. D. Shearer, S. J. Matthews, R. V. House, and M. B. Szein. 2008. An improved *Francisella tularensis* live vaccine strain (LVS) is well tolerated and highly immunogenic when administered to rabbits in escalating doses using various immunization routes. *Vaccine* 26:1773-85.
288. Passmore, L. A., and D. Barford. 2004. Getting into position: the catalytic mechanisms of protein ubiquitylation. *Biochem J* 379:513-25.
289. Perrin, A. J., X. Jiang, C. L. Birmingham, N. S. So, and J. H. Brumell. 2004. Recognition of bacteria in the cytosol of Mammalian cells by the ubiquitin system. *Curr Biol* 14:806-11.
290. Phillips, N. J., B. Schilling, M. K. McLendon, M. A. Apicella, and B. W. Gibson. 2004. Novel modification of lipid A of *Francisella tularensis*. *Infect Immun* 72:5340-8.
291. Pickart, C. M., and R. E. Cohen. 2004. Proteasomes and their kin: proteases in the machine age. *Nat Rev Mol Cell Biol* 5:177-87.
292. Picking, W. L., H. Nishioka, P. D. Hearn, M. A. Baxter, A. T. Harrington, A. Blocker, and W. D. Picking. 2005. IpaD of *Shigella flexneri* is independently required for regulation of Ipa protein secretion and efficient insertion of IpaB and IpaC into host membranes. *Infect Immun* 73:1432-40.
293. Pierini, L. M. 2006. Uptake of serum-opsonized *Francisella tularensis* by macrophages can be mediated by class A scavenger receptors. *Cell Microbiol* 8:1361-70.
294. Pines, J., and C. Lindon. 2005. Proteolysis: anytime, any place, anywhere? *Nat Cell Biol* 7:731-5.
295. Portnoy, D. A., P. S. Jacks, and D. J. Hinrichs. 1988. Role of hemolysin for the intracellular growth of *Listeria monocytogenes*. *J Exp Med* 167:1459-71.
296. Proctor, R. A., J. D. White, E. Ayala, and P. G. Canonico. 1975. Phagocytosis of *Francisella tularensis* by Rhesus monkey peripheral leukocytes. *Infect Immun* 11:146-51.
297. Pukatzki, S., A. T. Ma, D. Sturtevant, B. Krastins, D. Sarracino, W. C. Nelson, J. F. Heidelberg, and J. J. Mekalanos. 2006. Identification of a conserved bacterial protein secretion system in *Vibrio cholerae* using the *Dictyostelium* host model system. *Proc Natl Acad Sci U S A* 103:1528-33.

298. Pukatzki, S., S. B. McAuley, and S. T. Miyata. 2009. The type VI secretion system: translocation of effectors and effector-domains. *Curr Opin Microbiol* 12:11-7.
299. Qin, A., and B. J. Mann. 2006. Identification of transposon insertion mutants of *Francisella tularensis tularensis* strain Schu S4 deficient in intracellular replication in the hepatic cell line HepG2. *BMC Microbiol* 6:69.
300. Radulovic, S., J. M. Troyer, M. S. Beier, A. O. Lau, and A. F. Azad. 1999. Identification and molecular analysis of the gene encoding *Rickettsia typhi* hemolysin. *Infect Immun* 67:6104-8.
301. Ramachandra, L., W. H. Boom, and C. V. Harding. 2008. Class II MHC antigen processing in phagosomes. *Methods Mol Biol* 445:353-77.
302. Read, A., S. J. Vogl, K. Hueffer, L. A. Gallagher, and G. M. Happ. 2008. *Francisella* genes required for replication in mosquito cells. *J Med Entomol* 45:1108-16.
303. Reilly, T. J., G. S. Baron, F. E. Nano, and M. S. Kuhlenschmidt. 1996. Characterization and sequencing of a respiratory burst-inhibiting acid phosphatase from *Francisella tularensis*. *J. Biol. Chem.* 271:10973-10983.
304. Reintjes, R., I. Dedushaj, A. Gjini, T. R. Jorgensen, B. Cotter, A. Lieftucht, F. D'Ancona, D. T. Dennis, M. A. Kosoy, G. Mulliqi-Osmani, R. Grunow, A. Kalaveshi, L. Gashi, and I. Humolli. 2002. Tularemia outbreak investigation in Kosovo: case control and environmental studies. *Emerg Infect Dis* 8:69-73.
305. Reiter, W. D., P. Palm, and S. Yeats. 1989. Transfer RNA genes frequently serve as integration sites for prokaryotic genetic elements. *Nucleic Acids Res* 17:1907-14.
306. Renesto, P., P. Dehoux, E. Gouin, L. Touqui, P. Cossart, and D. Raoult. 2003. Identification and characterization of a phospholipase D-superfamily gene in rickettsiae. *J Infect Dis* 188:1276-83.
307. Rink, J., E. Ghigo, Y. Kalaidzidis, and M. Zerial. 2005. Rab conversion as a mechanism of progression from early to late endosomes. *Cell* 122:735-49.
308. Risseuw, E. P., T. E. Daskalchuk, T. W. Banks, E. Liu, J. Cotelesage, H. Hellmann, M. Estelle, D. E. Somers, and W. L. Crosby. 2003. Protein interaction analysis of SCF ubiquitin E3 ligase subunits from *Arabidopsis*. *Plant J* 34:753-67.
309. Robinson, C. G., and C. R. Roy. 2006. Attachment and fusion of endoplasmic reticulum with vacuoles containing *Legionella pneumophila*. *Cell Microbiol* 8:793-805.
310. Rohmer, L., M. Brittnacher, K. Svensson, D. Buckley, E. Haugen, Y. Zhou, J. Chang, R. Levy, H. Hayden, M. Forsman, M. Olson, A. Johansson, R. Kaul, and S. I. Miller. 2006. Potential source of *Francisella tularensis* live vaccine strain attenuation determined by genome comparison. *Infect Immun* 74:6895-906.
311. Romano, P. S., M. G. Gutierrez, W. Beron, M. Rabinovitch, and M. I. Colombo. 2007. The autophagic pathway is actively modulated by phase II *Coxiella burnetii* to efficiently replicate in the host cell. *Cell Microbiol* 9:891-909.
312. Rossi, L., B. Hohn, and B. Tinland. 1996. Integration of complete transferred DNA units is dependent on the activity of virulence E2 protein of *Agrobacterium tumefaciens*. *Proc Natl Acad Sci U S A* 93:126-30.

313. Roy, C. R., K. H. Berger, and R. R. Isberg. 1998. Legionella pneumophila DotA protein is required for early phagosome trafficking decisions that occur within minutes of bacterial uptake. *Mol Microbiol* 28:663-74.
314. Ruckdeschel, K., G. Pfaffinger, K. Trulzsch, G. Zenner, K. Richter, J. Heesemann, and M. Aepfelbacher. 2006. The proteasome pathway destabilizes Yersinia outer protein E and represses its antihost cell activities. *J Immunol* 176:6093-102.
315. Rytkonen, A., and D. W. Holden. 2007. Bacterial interference of ubiquitination and deubiquitination. *Cell Host Microbe* 1:13-22.
316. Salanoubat, M., S. Genin, F. Artiguenave, J. Gouzy, S. Mangenot, M. Arlat, A. Billault, P. Brottier, J. C. Camus, L. Cattolico, M. Chandler, N. Choisne, C. Claudel-Renard, S. Cunnac, N. Demange, C. Gaspin, M. Lavie, A. Moisan, C. Robert, W. Saurin, T. Schiex, P. Siguier, P. Thebault, M. Whalen, P. Wincker, M. Levy, J. Weissenbach, and C. A. Boucher. 2002. Genome sequence of the plant pathogen *Ralstonia solanacearum*. *Nature* 415:497-502.
317. Saleh, M. T., and J. T. Belisle. 2000. Secretion of an acid phosphatase (SapM) by *Mycobacterium tuberculosis* that is similar to eukaryotic acid phosphatases. *J Bacteriol* 182:6850-3.
318. Salomonsson, E., K. Kuoppa, A. L. Forslund, C. Zingmark, I. Golovliov, A. Sjostedt, L. Noppa, and A. Forsberg. 2009. Reintroduction of two deleted virulence loci restores full virulence to the live vaccine strain of *Francisella tularensis*. *Infect Immun* 77:3424-31.
319. Sammons-Jackson, W. L., K. McClelland, J. N. Manch-Citron, D. W. Metzger, C. S. Bakshi, E. Garcia, A. Rasley, and B. E. Anderson. 2008. Generation and characterization of an attenuated mutant in a response regulator gene of *Francisella tularensis* live vaccine strain (LVS). *DNA Cell Biol* 27:387-403.
320. Sandstrom, G. 1994. The tularaemia vaccine. *J Chem Technol Biotechnol* 59:315-20.
321. Sandström, G., A. Sjöstedt, T. Johansson, K. Kuoppa, and J. C. Williams. 1992. Immunogenicity and toxicity of lipopolysaccharide from *Francisella tularensis* LVS. *FEMS Microbiol. Immunol.* 105:201-210.
322. Santic, M., C. Akimana, R. Asare, J. C. Kouokam, S. Atay, and Y. A. Kwaik. 2009. Intracellular fate of *Francisella tularensis* within arthropod-derived cells. *Environ Microbiol* 11:1473-81.
323. Santic, M., R. Asare, I. Skrobonja, S. Jones, and Y. Abu Kwaik. 2008. Acquisition of the vacuolar ATPase proton pump and phagosome acidification are essential for escape of *Francisella tularensis* into the macrophage cytosol. *Infect Immun* 76:2671-7.
324. Santic, M., S. A. Khodor, and Y. A. Kwaik. 2009. Cell biology and molecular ecology of *Francisella tularensis*. *Cell Microbiol*.
325. Santic, M., M. Molmeret, and Y. Abu Kwaik. 2005. Modulation of biogenesis of the *Francisella tularensis* subsp. *novicida*-containing phagosome in quiescent human macrophages and its maturation into a phagolysosome upon activation by IFN-gamma. *Cell Microbiol* 7:957-67.

326. Santic, M., M. Molmeret, K. E. Klose, and Y. Abu Kwaik. 2006. *Francisella tularensis* travels a novel, twisted road within macrophages. *Trends Microbiol* 14:37-44.
327. Santic, M., M. Molmeret, K. E. Klose, S. Jones, and Y. A. Kwaik. 2005. The *Francisella tularensis* pathogenicity island protein IglC and its regulator MglA are essential for modulating phagosome biogenesis and subsequent bacterial escape into the cytoplasm. *Cell Microbiol* 7:969-79.
328. Saslaw, S., H. T. Eigelsbach, J. A. Prior, H. E. Wilson, and S. Carhart. 1961. Tularemia vaccine study. II. Respiratory challenge. *Archives of Internal Medicine* 107:134-146.
329. Saslaw, S., H. T. Eigelsbach, H. E. Wilson, J. A. Prior, and S. Carhart. 1961. Tularemia vaccine study. I. Intracutaneous challenge. *Archives of Internal Medicine* 107:121-133.
330. Sawyer, W. D., H. G. Dangerfield, A. L. Hogge, and D. Crozier. 1966. Antibiotic prophylaxis and therapy of airborne tularemia. *Bacteriol Rev* 30:542-50.
331. Scheel, O., T. Hoel, T. Sandvik, and B. P. Berdal. 1993. Susceptibility pattern of Scandinavian *Francisella tularensis* isolates with regard to oral and parenteral antimicrobial agents. *Apmis* 101:33-6.
332. Schell, M. A., R. L. Ulrich, W. J. Ribot, E. E. Brueggemann, H. B. Hines, D. Chen, L. Lipscomb, H. S. Kim, J. Mrazek, W. C. Nierman, and D. Deshazer. 2007. Type VI secretion is a major virulence determinant in *Burkholderia mallei*. *Mol Microbiol* 64:1466-85.
333. Schlesinger, L. S., C. G. Bellinger-Kawahara, N. R. Payne, and M. A. Horwitz. 1990. Phagocytosis of *Mycobacterium tuberculosis* is mediated by human monocyte complement receptors and complement component C3. *J Immunol* 144:2771-80.
334. Schmidt, H., and M. Hensel. 2004. Pathogenicity islands in bacterial pathogenesis. *Clin Microbiol Rev* 17:14-56.
335. Schnupf, P., and D. A. Portnoy. 2007. Listeriolysin O: a phagosome-specific lysin. *Microbes Infect* 9:1176-87.
336. Schrammeijer, B., E. Risseuw, W. Pansegrau, T. J. Regensburg-Tuink, W. L. Crosby, and P. J. Hooykaas. 2001. Interaction of the virulence protein VirF of *Agrobacterium tumefaciens* with plant homologs of the yeast Skp1 protein. *Curr Biol* 11:258-62.
337. Schulert, G. S., and L. A. Allen. 2006. Differential infection of mononuclear phagocytes by *Francisella tularensis*: role of the macrophage mannose receptor. *J Leukoc Biol* 80:563-71.
338. Schulman, B. A., A. C. Carrano, P. D. Jeffrey, Z. Bowen, E. R. Kinnucan, M. S. Finnin, S. J. Elledge, J. W. Harper, M. Pagano, and N. P. Pavletich. 2000. Insights into SCF ubiquitin ligases from the structure of the Skp1-Skp2 complex. *Nature* 408:381-6.
339. Scianimanico, S., M. Desrosiers, J. F. Dermine, S. Meresse, A. Descoteaux, and M. Desjardins. 1999. Impaired recruitment of the small GTPase rab7 correlates with the inhibition of phagosome maturation by *Leishmania donovani* promastigotes. *Cell Microbiol* 1:19-32.

340. Scott, C. C., R. J. Botelho, and S. Grinstein. 2003. Phagosome maturation: a few bugs in the system. *J Membr Biol* 193:137-52.
341. Scott, C. C., P. Cuellar-Mata, T. Matsuo, H. W. Davidson, and S. Grinstein. 2002. Role of 3-phosphoinositides in the maturation of Salmonella-containing vacuoles within host cells. *J Biol Chem* 277:12770-6.
342. Shaughnessy, L. M., A. D. Hoppe, K. A. Christensen, and J. A. Swanson. 2006. Membrane perforations inhibit lysosome fusion by altering pH and calcium in *Listeria monocytogenes* vacuoles. *Cell Microbiol* 8:781-92.
343. Sjostedt, A. 2006. Intracellular survival mechanisms of *Francisella tularensis*, a stealth pathogen. *Microbes Infect* 8:561-7.
344. Sjostedt, A. 2007. Tularemia: history, epidemiology, pathogen physiology, and clinical manifestations. *Ann N Y Acad Sci* 1105:1-29.
345. Smalle, J., and R. D. Vierstra. 2004. The ubiquitin 26S proteasome proteolytic pathway. *Annu Rev Plant Biol* 55:555-90.
346. Smith, A. C., J. T. Cirulis, J. E. Casanova, M. A. Scidmore, and J. H. Brumell. 2005. Interaction of the Salmonella-containing vacuole with the endocytic recycling system. *J Biol Chem* 280:24634-41.
347. Smith, A. C., W. D. Heo, V. Braun, X. Jiang, C. Macrae, J. E. Casanova, M. A. Scidmore, S. Grinstein, T. Meyer, and J. H. Brumell. 2007. A network of Rab GTPases controls phagosome maturation and is modulated by *Salmonella enterica* serovar Typhimurium. *J Cell Biol* 176:263-8.
348. Smith, G. A., H. Marquis, S. Jones, N. C. Johnston, D. A. Portnoy, and H. Goldfine. 1995. The two distinct phospholipases C of *Listeria monocytogenes* have overlapping roles in escape from a vacuole and cell-to-cell spread. *Infect Immun* 63:4231-7.
349. Soldati, T., and M. Schliwa. 2006. Powering membrane traffic in endocytosis and recycling. *Nat Rev Mol Cell Biol* 7:897-908.
350. Somsel Rodman, J., and A. Wandinger-Ness. 2000. Rab GTPases coordinate endocytosis. *J Cell Sci* 113 Pt 2:183-92.
351. Spallek, T., S. Robatzek, and V. Gohre. 2009. How microbes utilize host ubiquitination. *Cell Microbiol* 11:1425-34.
352. Stathopoulos, C., D. R. Hendrixson, D. G. Thanassi, S. J. Hultgren, J. W. St Geme, 3rd, and R. Curtiss, 3rd. 2000. Secretion of virulence determinants by the general secretory pathway in gram-negative pathogens: an evolving story. *Microbes Infect* 2:1061-72.
353. Stebbins, C. E., and J. E. Galan. 2001. Structural mimicry in bacterial virulence. *Nature* 412:701-5.
354. Steele-Mortimer, O., J. H. Brumell, L. A. Knodler, S. Meresse, A. Lopez, and B. B. Finlay. 2002. The invasion-associated type III secretion system of *Salmonella enterica* serovar Typhimurium is necessary for intracellular proliferation and vacuole biogenesis in epithelial cells. *Cell Microbiol* 4:43-54.
355. Steele-Mortimer, O., S. Meresse, J. P. Gorvel, B. H. Toh, and B. B. Finlay. 1999. Biogenesis of *Salmonella typhimurium*-containing vacuoles in epithelial cells involves interactions with the early endocytic pathway. *Cell Microbiol* 1:33-49.
356. Stenmark, S., D. Sunnemark, A. Bucht, and A. Sjostedt. 1999. Rapid local expression of interleukin-12, tumor necrosis factor alpha, and gamma interferon

- after cutaneous *Francisella tularensis* infection in tularemia-immune mice. *Infect Immun* 67:1789-97.
357. Sturgill-Koszycki, S., and M. S. Swanson. 2000. *Legionella pneumophila* replication vacuoles mature into acidic, endocytic organelles. *J Exp Med* 192:1261-72.
  358. Suarez, G., J. C. Sierra, J. Sha, S. Wang, T. E. Erova, A. A. Fadl, S. M. Foltz, A. J. Horneman, and A. K. Chopra. 2008. Molecular characterization of a functional type VI secretion system from a clinical isolate of *Aeromonas hydrophila*. *Microb Pathog* 44:344-61.
  359. Swanson, M. S., and E. Fernandez-Moreira. 2002. A microbial strategy to multiply in macrophages: the pregnant pause. *Traffic* 3:170-7.
  360. Swanton, E., N. Bishop, J. Sheehan, S. High, and P. Woodman. 2000. Disassembly of membrane-associated NSF 20S complexes is slow relative to vesicle fusion and is Ca<sup>2+</sup>-independent. *J Cell Sci* 113 ( Pt 10):1783-91.
  361. Tapper, H., W. Furuya, and S. Grinstein. 2002. Localized exocytosis of primary (lysosomal) granules during phagocytosis: role of Ca<sup>2+</sup>-dependent tyrosine phosphorylation and microtubules. *J Immunol* 168:5287-96.
  362. Tarnvik, A., and L. Berglund. 2003. Tularaemia. *Eur Respir J* 21:361-73.
  363. Tarnvik, A., and M. C. Chu. 2007. New approaches to diagnosis and therapy of tularemia. *Ann N Y Acad Sci* 1105:378-404.
  364. Tarnvik, A., M. Ericsson, I. Golovliov, G. Sandstrom, and A. Sjostedt. 1996. Orchestration of the protective immune response to intracellular bacteria: *Francisella tularensis* as a model organism. *FEMS Immunol Med Microbiol* 13:221-5.
  365. Tarnvik, A., H. S. Priebe, and R. Grunow. 2004. Tularaemia in Europe: an epidemiological overview. *Scand J Infect Dis* 36:350-5.
  366. Telepnev, M., I. Golovliov, T. Grundstrom, A. Tarnvik, and A. Sjostedt. 2003. *Francisella tularensis* inhibits Toll-like receptor-mediated activation of intracellular signalling and secretion of TNF- $\alpha$  and IL-1 from murine macrophages. *Cell. Microbiol.* 5:41-51.
  367. Telepnev, M., I. Golovliov, and A. Sjostedt. 2005. *Francisella tularensis* LVS initially activates but subsequently down-regulates intracellular signaling and cytokine secretion in mouse monocytic and human peripheral blood mononuclear cells. *Microb Pathog* 38:239-47.
  368. Tempel, R., X. H. Lai, L. Crosa, B. Kozlowicz, and F. Heffron. 2006. Attenuated *Francisella novicida* transposon mutants protect mice against wild-type challenge. *Infect Immun* 74:5095-105.
  369. Teutsch, S. M., W. J. Martone, E. W. Brink, M. E. Potter, G. Eliot, R. Hoxsie, R. B. Craven, and A. F. Kaufmann. 1979. Pneumonic tularemia on Martha's Vineyard. *N. Engl. J. Med.* 301: 826-828.
  370. Teyssie, N., J. A. Boudier, and D. Raoult. 1995. *Rickettsia conorii* entry into Vero cells. *Infect Immun* 63:366-74.
  371. Thakran, S., H. Li, C. L. Lavine, M. A. Miller, J. E. Bina, X. R. Bina, and F. Re. 2008. Identification of *Francisella tularensis* lipoproteins that stimulate the toll-like receptor (TLR) 2/TLR1 heterodimer. *J Biol Chem* 283:3751-60.

372. Thorpe, B. D., and S. Marcus. 1965. Phagocytosis and Intracellular Fate of *Pasteurella Tularensis*. 3. in Vivo Studies with Passively Transferred Cells and Sera. *J Immunol* 94:578-85.
373. Thrower, J. S., L. Hoffman, M. Rechsteiner, and C. M. Pickart. 2000. Recognition of the polyubiquitin proteolytic signal. *Embo J* 19:94-102.
374. Tilley, S. J., E. V. Orlova, R. J. Gilbert, P. W. Andrew, and H. R. Saibil. 2005. Structural basis of pore formation by the bacterial toxin pneumolysin. *Cell* 121:247-56.
375. Tilney, L. G., O. S. Harb, P. S. Connelly, C. G. Robinson, and C. R. Roy. 2001. How the parasitic bacterium *Legionella pneumophila* modifies its phagosome and transforms it into rough ER: implications for conversion of plasma membrane to the ER membrane. *J Cell Sci* 114:4637-50.
376. Tjelle, T. E., T. Lovdal, and T. Berg. 2000. Phagosome dynamics and function. *Bioessays* 22:255-63.
377. Trent, M. S., C. M. Stead, A. X. Tran, and J. V. Hankins. 2006. Diversity of endotoxin and its impact on pathogenesis. *J Endotoxin Res* 12:205-23.
378. Twine, S. M., N. C. Mykytczuk, M. D. Petit, H. Shen, A. Sjostedt, J. Wayne Conlan, and J. F. Kelly. 2006. In vivo proteomic analysis of the intracellular bacterial pathogen, *Francisella tularensis*, isolated from mouse spleen. *Biochem Biophys Res Commun* 345:1621-33.
379. Tyagi, R., R. Lai, and R. G. Duggleby. 2004. A new approach to 'megaprimer' polymerase chain reaction mutagenesis without an intermediate gel purification step. *BMC Biotechnol* 4:2.
380. Tzfira, T., M. Vaidya, and V. Citovsky. 2004. Involvement of targeted proteolysis in plant genetic transformation by *Agrobacterium*. *Nature* 431:87-92.
381. Ullrich, O., H. Horiuchi, C. Bucci, and M. Zerial. 1994. Membrane association of Rab5 mediated by GDP-dissociation inhibitor and accompanied by GDP/GTP exchange. *Nature* 368:157-60.
382. Vanhaesebroeck, B., and M. D. Waterfield. 1999. Signaling by distinct classes of phosphoinositide 3-kinases. *Exp Cell Res* 253:239-54.
383. Vazquez-Boland, J. A., M. Kuhn, P. Berche, T. Chakraborty, G. Dominguez-Bernal, W. Goebel, B. Gonzalez-Zorn, J. Wehland, and J. Kreft. 2001. *Listeria* pathogenesis and molecular virulence determinants. *Clin Microbiol Rev* 14:584-640.
384. Veiga, E., and P. Cossart. 2005. Ubiquitination of intracellular bacteria: a new bacteria-sensing system? *Trends Cell Biol* 15:2-5.
385. Vergne, I., J. Chua, and V. Deretic. 2003. Tuberculosis toxin blocking phagosome maturation inhibits a novel Ca<sup>2+</sup>/calmodulin-PI3K hVPS34 cascade. *J Exp Med* 198:653-9.
386. Vergne, I., J. Chua, H. H. Lee, M. Lucas, J. Belisle, and V. Deretic. 2005. Mechanism of phagolysosome biogenesis block by viable *Mycobacterium tuberculosis*. *Proc Natl Acad Sci U S A* 102:4033-8.
387. Vergunst, A. C., B. Schrammeijer, A. den Dulk-Ras, C. M. de Vlaam, T. J. Regensburg-Tuink, and P. J. Hooykaas. 2000. VirB/D4-dependent protein translocation from *Agrobacterium* into plant cells. *Science* 290:979-82.

388. Vergunst, A. C., M. C. van Lier, A. den Dulk-Ras, T. A. Stuve, A. Ouwehand, and P. J. Hooykaas. 2005. Positive charge is an important feature of the C-terminal transport signal of the VirB/D4-translocated proteins of *Agrobacterium*. *Proc Natl Acad Sci U S A* 102:832-7.
389. Via, L. E., D. Deretic, R. J. Ulmer, N. S. Hibler, L. A. Huber, and V. Deretic. 1997. Arrest of mycobacterial phagosome maturation is caused by a block in vesicle fusion between stages controlled by rab5 and rab7. *J Biol Chem* 272:13326-31.
390. Viboud, G. I., and J. B. Bliska. 2001. A bacterial type III secretion system inhibits actin polymerization to prevent pore formation in host cell membranes. *Embo J* 20:5373-82.
391. Vieira, O. V., R. J. Botelho, L. Rameh, S. M. Brachmann, T. Matsuo, H. W. Davidson, A. Schreiber, J. M. Backer, L. C. Cantley, and S. Grinstein. 2001. Distinct roles of class I and class III phosphatidylinositol 3-kinases in phagosome formation and maturation. *J Cell Biol* 155:19-25.
392. Vieira, O. V., R. E. Harrison, C. C. Scott, H. Stenmark, D. Alexander, J. Liu, J. Gruenberg, A. D. Schreiber, and S. Grinstein. 2004. Acquisition of Hrs, an essential component of phagosomal maturation, is impaired by mycobacteria. *Mol Cell Biol* 24:4593-604.
393. Vinogradov, E., M. B. Perry, and J. W. Conlan. 2002. Structural analysis of *Francisella tularensis* lipopolysaccharide. *Eur J Biochem* 269:6112-8.
394. Volinia, S., R. Dhand, B. Vanhaesebroeck, L. K. MacDougall, R. Stein, M. J. Zvelebil, J. Domin, C. Panaretou, and M. D. Waterfield. 1995. A human phosphatidylinositol 3-kinase complex related to the yeast Vps34p-Vps15p protein sorting system. *Embo J* 14:3339-48.
395. Von Pawel-Rammingen, U., M. V. Telepnev, G. Schmidt, K. Aktories, H. Wolf-Watz, and R. Rosqvist. 2000. GAP activity of the *Yersinia* YopE cytotoxin specifically targets the Rho pathway: a mechanism for disruption of actin microfilament structure. *Mol Microbiol* 36:737-48.
396. Vonkavaara, M., M. V. Telepnev, P. Ryden, A. Sjostedt, and S. Stoven. 2008. *Drosophila melanogaster* as a model for elucidating the pathogenicity of *Francisella tularensis*. *Cell Microbiol* 10:1327-38.
397. Voth, D. E., and R. A. Heinzen. 2007. Lounging in a lysosome: the intracellular lifestyle of *Coxiella burnetii*. *Cell Microbiol* 9:829-40.
398. Walker, D. H., H. M. Feng, and V. L. Popov. 2001. Rickettsial phospholipase A2 as a pathogenic mechanism in a model of cell injury by typhus and spotted fever group rickettsiae. *Am J Trop Med Hyg* 65:936-42.
399. Wang, R. F., and S. R. Kushner. 1991. Construction of versatile low-copy-number vectors for cloning, sequencing and gene expression in *Escherichia coli*. *Gene* 100:195-199.
400. Wang, X., S. C. McGrath, R. J. Cotter, and C. R. Raetz. 2006. Expression cloning and periplasmic orientation of the *Francisella novicida* lipid A 4'-phosphatase LpxF. *J Biol Chem* 281:9321-30.
401. Wasylnka, J. A., M. A. Bakowski, J. Szeto, M. B. Ohlson, W. S. Trimble, S. I. Miller, and J. H. Brumell. 2008. Role for myosin II in regulating positioning of

- Salmonella-containing vacuoles and intracellular replication. *Infect Immun* 76:2722-35.
402. Weiss, D. S., A. Brotcke, T. Henry, J. J. Margolis, K. Chan, and D. M. Monack. 2007. In vivo negative selection screen identifies genes required for *Francisella* virulence. *Proc Natl Acad Sci U S A* 104:6037-42.
403. Wherry, W. B. a. B. H. L. 1914. Infection of a man with *Bacterium tularense*. *J. Infect. Dis.* 15:331-340
404. Whitworth, T., V. L. Popov, X. J. Yu, D. H. Walker, and D. H. Bouyer. 2005. Expression of the *Rickettsia prowazekii* *pld* or *tlyC* gene in *Salmonella enterica* serovar Typhimurium mediates phagosomal escape. *Infect Immun* 73:6668-73.
405. Wieland, H., F. Goetz, and B. Neumeister. 2004. Phagosomal acidification is not a prerequisite for intracellular multiplication of *Legionella pneumophila* in human monocytes. *J Infect Dis* 189:1610-4.
406. Williams, M. D., T. X. Ouyang, and M. C. Flickinger. 1994. Starvation-induced expression of *SspA* and *SspB*: the effects of a null mutation in *sspA* on *Escherichia coli* protein synthesis and survival during growth and prolonged starvation. *Mol Microbiol* 11:1029-43.
407. Wu, H. Y., P. C. Chung, H. W. Shih, S. R. Wen, and E. M. Lai. 2008. Secretome analysis uncovers an Hcp-family protein secreted via a type VI secretion system in *Agrobacterium tumefaciens*. *J Bacteriol* 190:2841-50.
408. Xu, Y., H. Hortsman, L. Seet, S. H. Wong, and W. Hong. 2001. SNX3 regulates endosomal function through its PX-domain-mediated interaction with PtdIns(3)P. *Nat Cell Biol* 3:658-66.
409. Yee, D., T. R. Rhinehart-Jones, and K. L. Elkins. 1996. Loss of either CD4+ or CD8+ T cells does not affect the magnitude of protective immunity to an intracellular pathogen, *Francisella tularensis* strain LVS. *J. Immunol.* 157:5042-5048.
410. Yoon, S., Z. Liu, Y. Eyobo, and K. Orth. 2003. *Yersinia* effector YopJ inhibits yeast MAPK signaling pathways by an evolutionarily conserved mechanism. *J Biol Chem* 278:2131-5.
411. Yoshida, S., E. Katayama, A. Kuwae, H. Mimuro, T. Suzuki, and C. Sasakawa. 2002. *Shigella* deliver an effector protein to trigger host microtubule destabilization, which promotes Rac1 activity and efficient bacterial internalization. *Embo J* 21:2923-35.
412. Zhang, Y., W. Higashide, S. Dai, D. M. Sherman, and D. Zhou. 2005. Recognition and ubiquitination of *Salmonella* type III effector SopA by a ubiquitin E3 ligase, HsRMA1. *J Biol Chem* 280:38682-8.
413. Zhang, Y., W. M. Higashide, B. A. McCormick, J. Chen, and D. Zhou. 2006. The inflammation-associated *Salmonella* SopA is a HECT-like E3 ubiquitin ligase. *Mol Microbiol* 62:786-93.
414. Zheng, J., Leung, K. Y. 2007. Dissection of a type VI secretion system in *Edwardsiella tarda*. *Mol. Microbiol.*
415. Zhou, D., L. M. Chen, L. Hernandez, S. B. Shears, and J. E. Galan. 2001. A *Salmonella* inositol polyphosphatase acts in conjunction with other bacterial effectors to promote host cell actin cytoskeleton rearrangements and bacterial internalization. *Mol Microbiol* 39:248-59.

416. Zhou, H., D. M. Monack, N. Kayagaki, I. Wertz, J. Yin, B. Wolf, and V. M. Dixit. 2005. Yersinia virulence factor YopJ acts as a deubiquitinase to inhibit NF-kappa B activation. *J Exp Med* 202:1327-32.
417. Zhou, L., A. Tan, and M. B. Hershenson. 2004. Yersinia YopJ inhibits pro-inflammatory molecule expression in human bronchial epithelial cells. *Respir Physiol Neurobiol* 140:89-97.
418. Ziemienowicz, A., T. Merkle, F. Schoumacher, B. Hohn, and L. Rossi. 2001. Import of Agrobacterium T-DNA into plant nuclei: two distinct functions of VirD2 and VirE2 proteins. *Plant Cell* 13:369-83.
419. Zychlinsky, A., B. Kenny, R. Menard, M. C. Prevost, I. B. Holland, and P. J. Sansonetti. 1994. IpaB mediates macrophage apoptosis induced by *Shigella flexneri*. *Mol Microbiol* 11:619-27.